



S-Series™

2.0 Chute Manifold Check Valve and Water Pump/Chute Supply Shut-Off Valve

Date: March 25, 2026
Bulletin Name: FDM-SVC-044
Model: Oshkosh S-Series
Units Affected: 2.0 Front Discharge Mixers

Purpose

This bulletin provides instructions to install a check valve in the chute return hydraulic circuit to prevent fluid back flow through the chute manifold if a chute up or down hose fails, and install a shut-off valve on the fan manifold to turn off flow of hydraulic oil to the chutes and water pump.

Notice

- Read and understand this bulletin in its entirety before performing this procedure.
- All procedures outlined in the bulletin must be performed by skilled service personnel. Refer to the product service manual for descriptions of maintenance procedures.

SAFETY NOTICE

Perform your company’s Lockout/Tagout procedure. If your company does not have a Lockout/Tagout procedure, follow OSHA 1910.147 and 1910.146 Confined Space as appropriate.

SAFETY NOTICE

Use appropriate Personal Protective Equipment (PPE) as required by your company.

⚠ WARNING

Hydraulic systems operate under high pressure—only experienced persons should attempt repairs or troubleshooting on hydraulic systems.

⚠ WARNING

Never remove hydraulic pipes/tubing, fittings, and adapters until all pressure has been relieved from the hydraulic system.

⚠ WARNING

All hydraulic pressures must be relieved from the hydraulic system prior to removing any components from the system to prevent oil from spraying or functions and systems from failing.

Tools and Equipment Required

Customer to supply:

- Hand tools
- Torque wrench (foot pounds)

Parts Required

Chute Manifold Check Valve (Steps 3-16)

Item	Part Number	Description	Qty.
1	A000C018	CABLE TIE 6.30 X 0.20	3
2	A000D112	FTG, T 10JIC - 10JIC - 10JIC MFM ST	1
3	A000V815	PROTECTOR, HOSE 4" BLK	1
4	A001H978	VALVE, HYD, CHK, HYD, 10ORG,ST	1
5	A001H980	HOSE ASSY #8 CR 12.0 3125	1

Water Pump/Chute Supply Shut-Off Valve (Steps 17-29)

Item	Part Number	Description	Qty.
1	A000B696	FTG, 45 8JIC-8ORG MM ST	1
2	A000B931	FTG, ST 8JIC-8ORG FM ST SWVL	1
3	A000C018	CABLE TIE 6.30 X 0.20	3
4	A001H932	VALVE, HYD, BALL, MNL, 8ORG, ST	1

Procedure

Lockout/Tagout

- Place unit on a flat surface, engage parking brake, chock truck tires, and perform your company's Lockout/Tagout procedure. If your company does not have a Lockout/Tagout procedure, follow OSHA 1910.147 and 1910.146 Confined Space as appropriate.
- The vehicle's BATTERY DISCONNECT switch is located on the left-hand side of the battery box. Use the battery disconnect switch when performing any maintenance so the vehicle cannot accidentally be started.
 - Turn the battery disconnect switch (Figure A, Item 1) counterclockwise so the hole on the switch aligns with the hole in the bracket (Figure A, Item 2).
 - Install the safety lockout device ring (Figure B, Item 1) through the holes on the battery disconnect switch and the bracket.
 - Install a padlock (Figure B, Item 2) onto the safety lockout device ring, lock it, and put the key in your pocket. If more than one person is working on the vehicle, each person must install his or her own padlock.

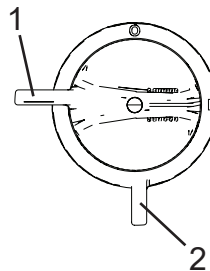

Figure A

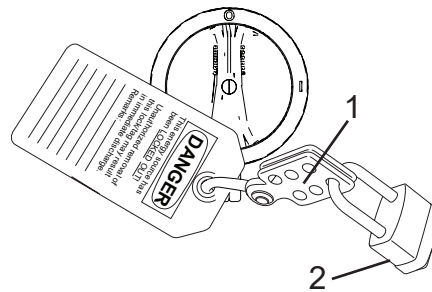

Figure B

Chute Manifold Check Valve Installation

3. Locate chute manifold behind the front bumper. See Figure 1.

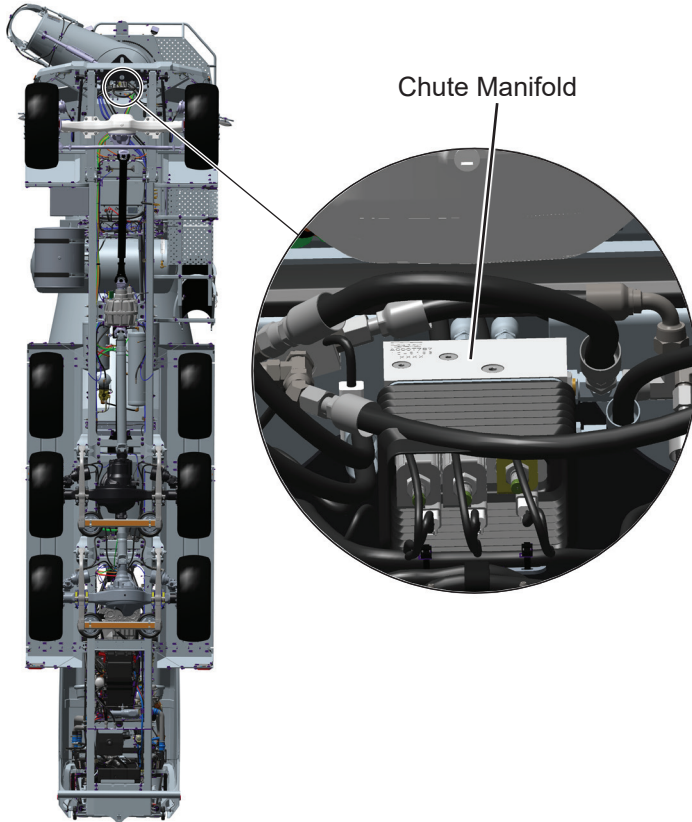

Figure 1. Chute Manifold

4. Disconnect and remove hydraulic hose #3125 between outer T-fitting and steering manifold. See Figure 2. Hydraulic hose will not be reused.

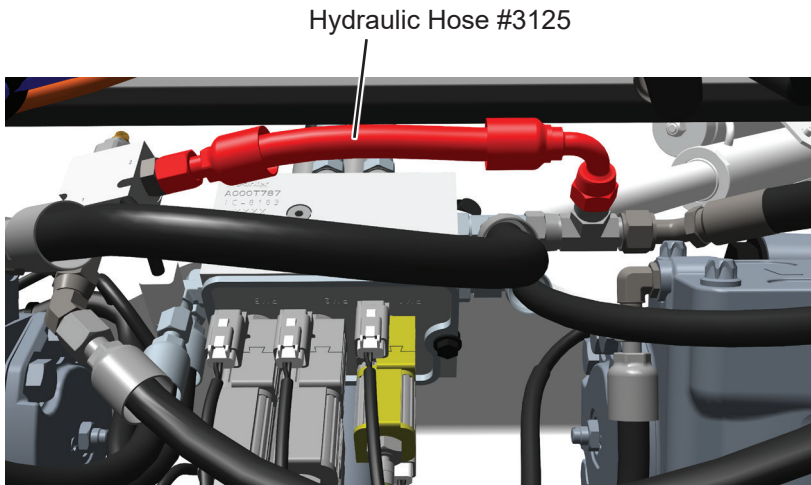

Figure 2. Chute Manifold Hose Removal

5. Disconnect hydraulic hose #3124 from chute manifold inner T-fitting. See Figure 3. Cap/cover end of hydraulic hose to prevent contamination and tie hose end to side.

Hydraulic Hose #3124

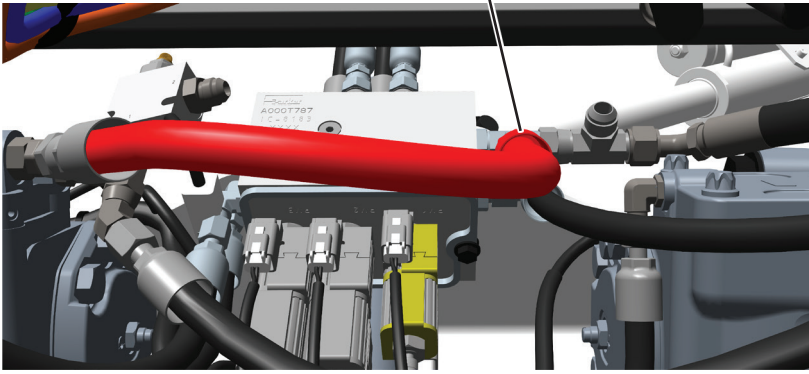

Figure 3. Chute Manifold Hose Removal

6. Disconnect hydraulic hose #3126 from end of chute manifold outer T-fitting. See Figure 4. Cap/cover end of hydraulic hose to prevent contamination and tie hose end to side.

Hydraulic Hose #3126

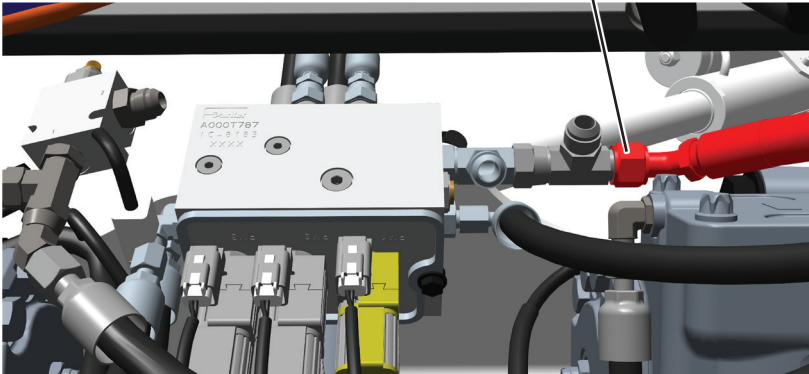

Figure 4. Chute Manifold Hose Disconnect

7. Loosen and remove outer T-fitting from end of chute manifold. See Figure 5. Save T-fitting for reinstallation.

T-Fitting

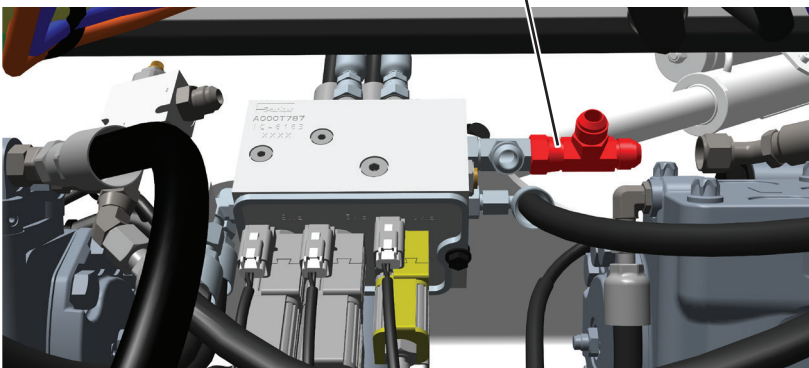

Figure 5. Chute Manifold T-Fitting Removal

8. Loosen and remove inner T-fitting from end of chute manifold. See Figure 6. T-fitting will not be reused.

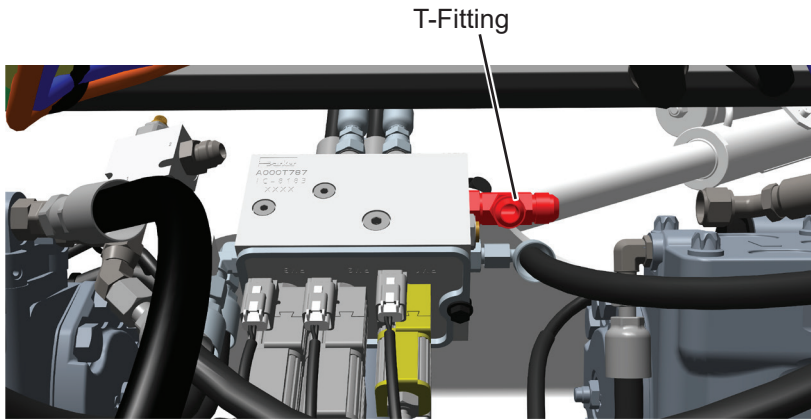

Figure 6. Chute Manifold T-Fitting Removal

9. Install check valve in chute manifold where inner T-fitting was removed in Step 8. See Figure 7. Final tighten check valve to 58 ft. lbs.

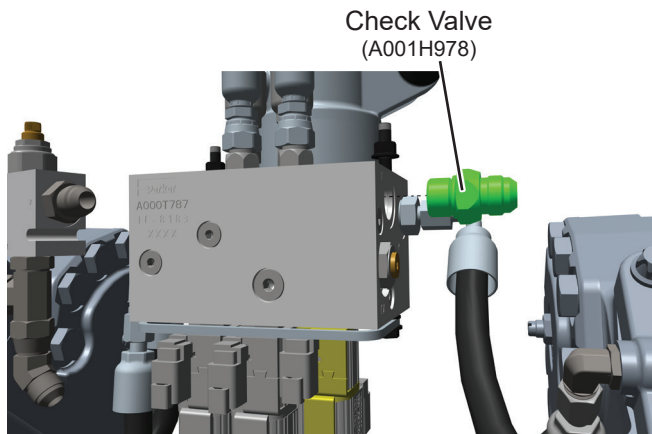

Figure 7. Chute Manifold Check Valve Installation

10. Install inner T-fitting (A000D112) on check valve installed in Step 9. See Figure 8. Orient T-fitting and final tighten to 58 ft. lbs.

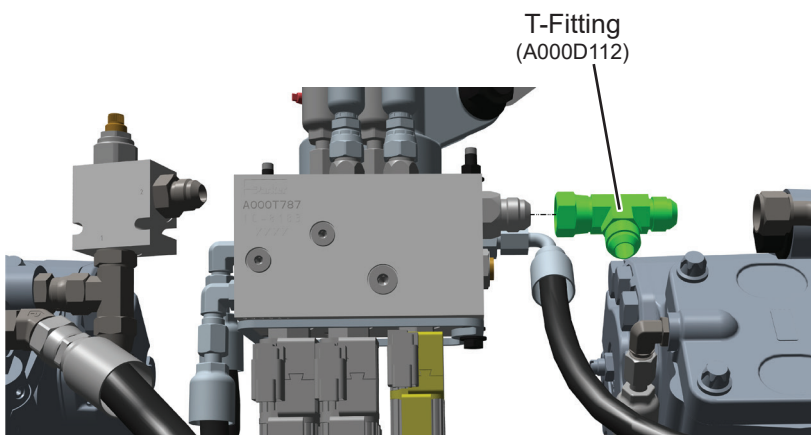

Figure 8. Chute Manifold T-Fitting Installation

11. Install outer T-fitting removed in Step 7 on inner T-fitting installed in Step 10. See Figure 9. Orient T-fitting and final tighten to 58 ft. lbs.

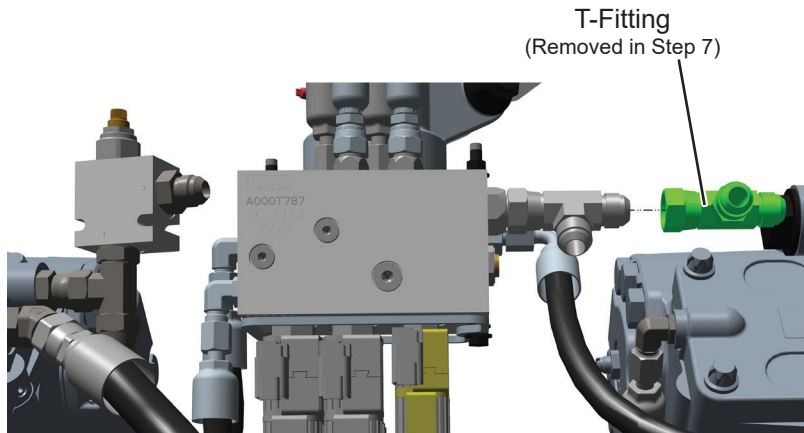

Figure 9. Chute Manifold T-Fitting Installation

12. Reconnect hydraulic hose #3124 disconnected in Step 5 to inner T-fitting. See Figure 10. Final tighten hose end to 58 ft. lbs.
13. Reconnect hydraulic hose #3126 disconnected in Step 6 to inner T-fitting. See Figure 10. Final tighten hose end to 58 ft. lbs.

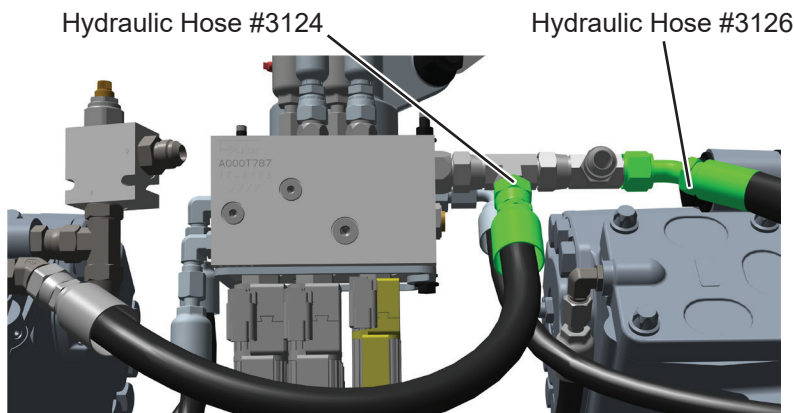

Figure 10. Chute Manifold Hose Connections

14. Connect straight end of hydraulic hose #3125 (A001H980) to steering manifold. See Figure 11. Final tighten hose end to 45 ft. lbs.
15. Connect 90° end of hydraulic hose #3125 (A001H980) to outer T-fitting installed in Step 11. See Figure 11. Final tighten hose end to 58 ft. lbs.

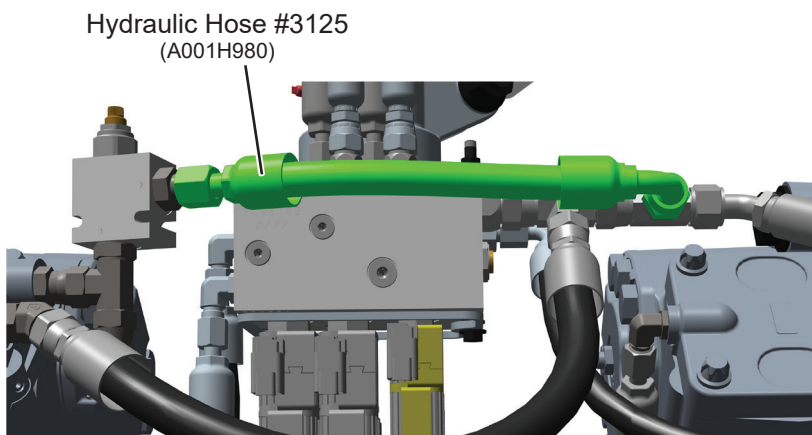

Figure 11. Chute Manifold Hose Installation

16. Install hose protector (A000V815) on hydraulic hose #3126 near right-hand steering gear mount. See Figure 12. Secure hose protector with cable ties (A000C018).

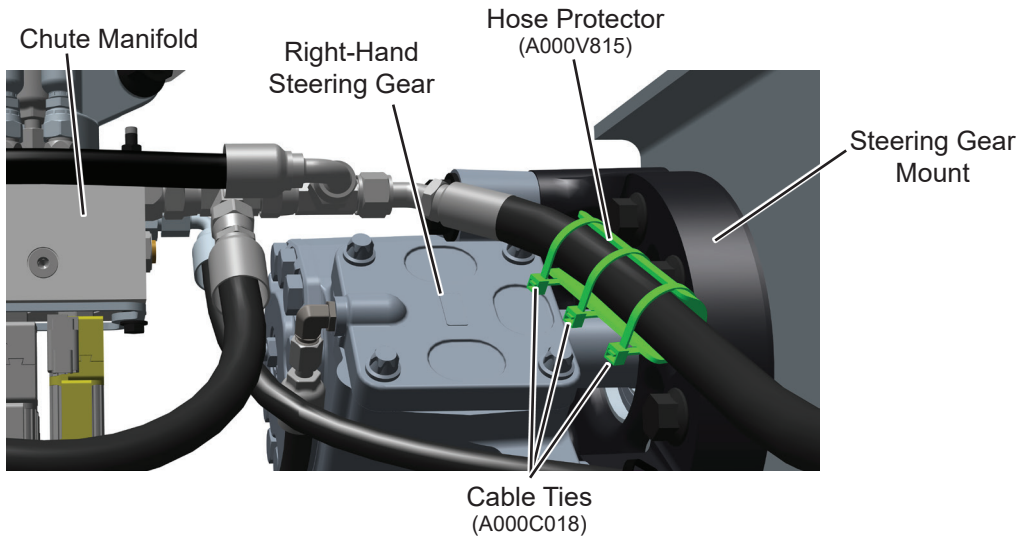

Figure 12. Hose Protector Installation

Water Pump/Chute Supply Shut-Off Valve Installation

17. Install straight fitting (A000B931) in end of ball valve (A001H932). See Figure 13. Final tighten straight fitting to 63 ft. lbs.

18. Install 45° fitting in other end of ball valve. See Figure 13. Final tighten 45° fitting to 63 ft. lbs.

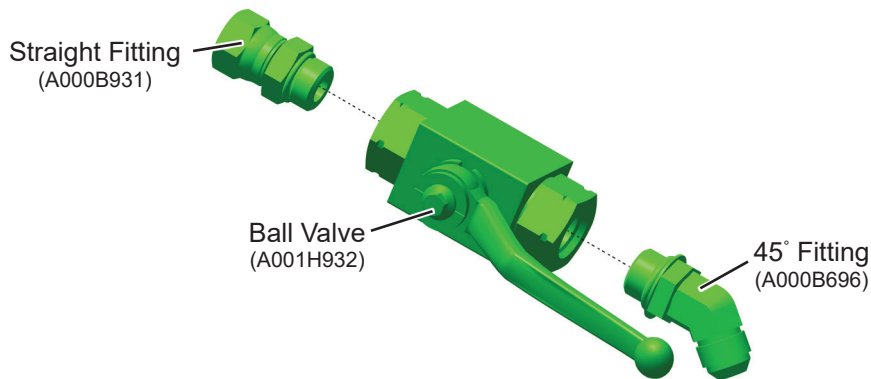

Figure 13. Ball Valve Assembly

19. Open hood hatch and locate fan manifold. See Figure 14.
20. Place a container below fan manifold to catch any hydraulic oil that may drain from manifold or hydraulic hose.
21. Loosen and remove end of hydraulic hose #3041 connected to fan manifold chute supply port "S" 90° elbow. See Figure 14.
22. Cap/cover end of hydraulic hose to prevent contamination and tie hose end to side.

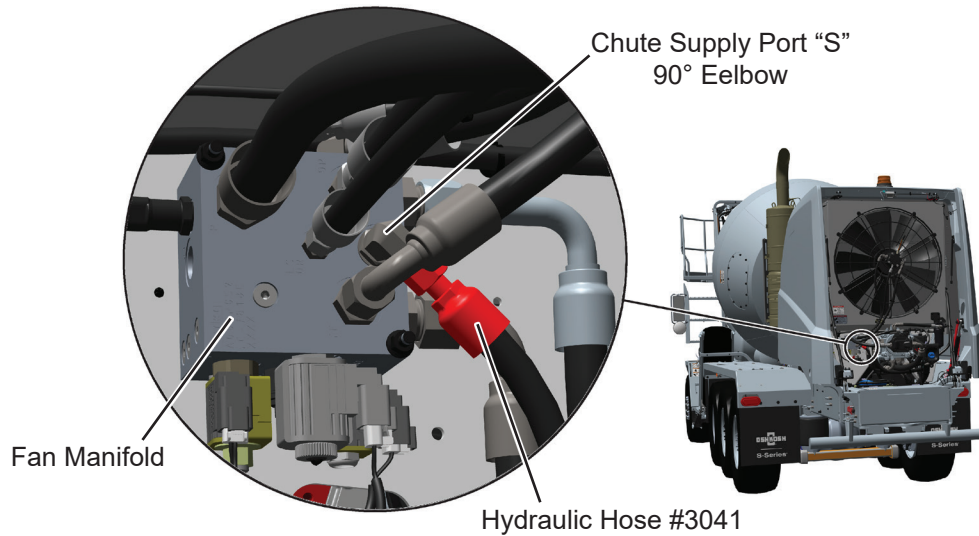

Figure 14. Fan Manifold

23. Install ball valve assembly straight fitting on fan manifold chute supply port "S" 90° fitting. See Figure 15. Final tighten straight fitting on 90° fitting to 45 ft. lbs. Figure 15 shows ball valve in open position. Rotate handle 90° to close ball valve and stop flow of hydraulic oil.

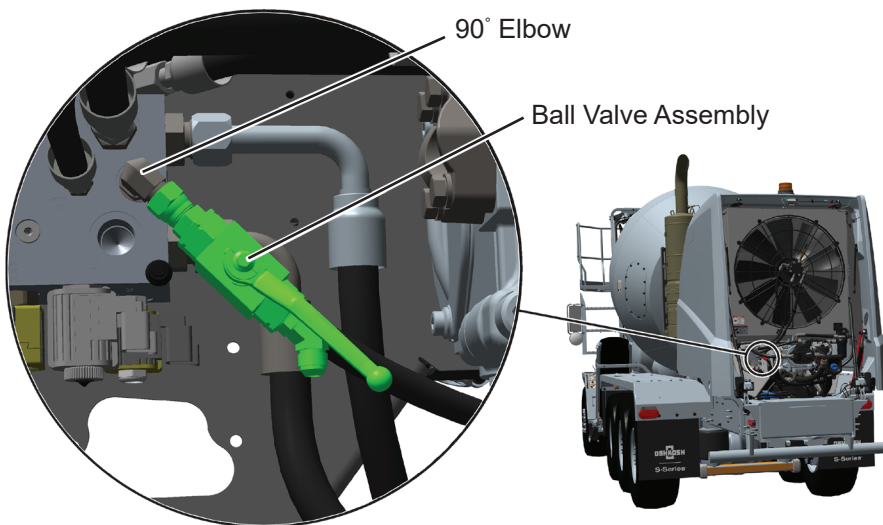

Figure 15. Ball Valve Assembly

24. Reconnect hydraulic hose #3041 disconnected in Step 21 to ball valve assembly 45° fitting. See Figure 16. Final tighten hose end to 45 ft. lbs.
25. Route hydraulic hose #3041 and secure with cable ties (A000C018) as shown in Figure 16.

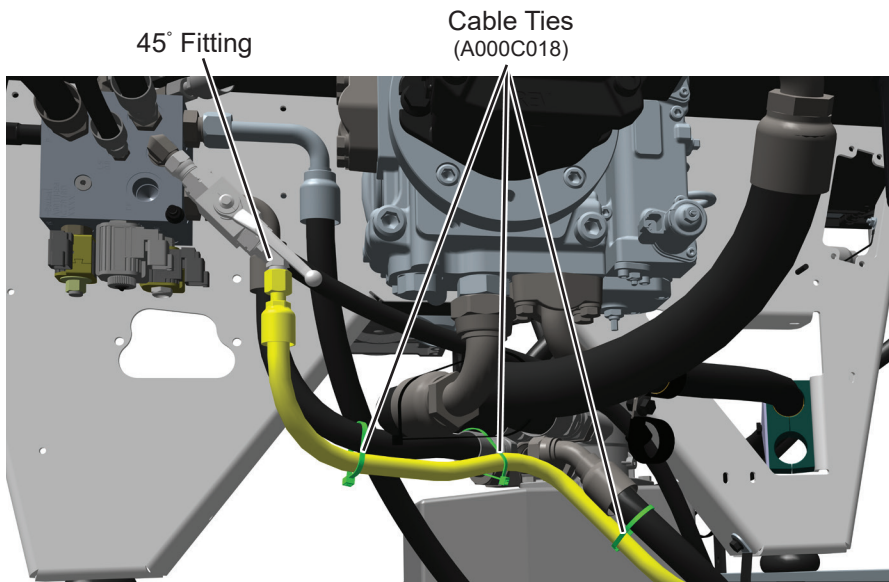

Figure 16. Hose Routing

26. Remove container from below fan manifold and dispose of any hydraulic oil according to local regulations.
27. Clean fan manifold area where hydraulic hose was loosened.
28. Close and secure hood hatch.
29. Remove lockout/tagout and tire chocks

Continuous Improvement:

The change included in this document is part of the Oshkosh® S-Series™ Continuous Improvement Process.

Oshkosh S-Series' quality policy is providing customer satisfaction through innovative products, dedicated service, and a constant focus on continuous improvement.



S-Series

(888) 686-7278

www.streetsmartparts.com