

2026 Prius and Prius PHV Pre-Delivery Service (PDS)

Service Category General

Section Pre-Delivery Service

Market USA

Toyota Supports
 ASE Certification 

Applicability

YEAR(S)	MODEL(S)	ADDITIONAL INFORMATION
2026	Prius, Prius PHV	

REVISION NOTICE

May 27, 2026 Rev1:

- The **Customize ACC Function** section has been removed.
- The **Introduction, Required Tools & Equipment, and D/C Cut Fuse Installation** sections have been updated.

Any previous printed versions of this bulletin should be discarded.

Introduction

Pre-Delivery Service (PDS) is a critical step in satisfying our new car customers. Customer feedback indicates the following areas deserve special attention when performing PDS:

- Careful inspection for paint chips/scratches and body dents/dings.
- Proper operation of electrical accessories (including interior light, clock, and radio reset).
- Interior cleanliness.
- Proper function of mechanical systems.

The PDS process helps identify potential vehicle concerns before customer delivery. After completing the PDS process, maintain accurate PDS records by ensuring the required documents listed below are completed and recorded in accordance with Toyota Warranty Policy.

- GTS+ Health Check
- Completed PDS Check Sheet
- Battery Charge Test Print Out
- GTS+ Tire Pressure Information

Customer retention and proper maintenance of vehicles are and have always been a major focus for Toyota. To help remind customers that regular service is essential to the proper maintenance of the vehicle, dealers are required to install a service reminder sticker before delivery. By doing this, customers will be reminded to return to your dealership for service. Your current service reminder sticker may be used. (See PDS *Check Sheet* item 7 of “Final Inspection and Cleaning.”)

2026 Prius and Prius PHV Pre-Delivery Service (PDS)

Introduction (continued)

This bulletin contains the PDS procedures that apply specifically to 2026 model year Prius and Prius PHV vehicles.

Refer to [T-SB-0023-25](#), the universal *Check Sheet* that contains PDS steps that apply to all 2026 model year Toyota vehicles. To properly perform a complete PDS, you must complete all procedures contained in this TSB as well as the universal PDS *Check Sheet*.

In addition, if the vehicle is stored for over 30 days, refer to [T-SB-0002-26](#), *Long-Term Vehicle Storage Guidelines*.

Refer to the table below for a definition of terms that may be used in this bulletin.

Table 1.

TERM	ACRONYM	DEFINITION
Conventional Vehicle	CV	A vehicle with only a gasoline engine for propulsion
Electrified Vehicle	EV	A vehicle that utilizes a hybrid, plug-in hybrid, fuel cell, or battery electric system for propulsion
Hybrid Electric Vehicle	HEV	A vehicle with both a gasoline engine and an HV Battery
Plug-in Hybrid Electric Vehicle	PHEV	A vehicle with both a gasoline engine and an HV Battery that can be charged externally
Battery Electric Vehicle	BEV	A vehicle with only an HV Battery that can be charged externally
Fuel Cell Electric Vehicle	FCEV	A vehicle with both a hydrogen fuel cell and an HV Battery
State of Charge	SOC	The remaining capacity available in a battery
12-Volt	12V	Standard 12V battery used to power electrical systems separate from high voltage components
High Voltage	HV	HV Battery used to power the electrified vehicle

2026 Prius and Prius PHV Pre-Delivery Service (PDS)

Table of Contents

- [Warranty Policy](#)..... 4
- [Warranty Information](#) 4
- [Required Tools and Equipment](#)..... 4
- [D/C Cut Fuse Installation](#)..... 5
- [Front License Plate and Mounting Bracket Installation](#)* 6
- [Front and Rear Emergency Towing Eyelet Removal and Hole Cover Installation](#)..... 9
- [Power Back Door Initialization](#)..... 12
- [Tire Pressure Warning System \(TPWS\) Initialization](#) 12
- [Enable Hybrid Battery Thermal Keep Control Mode](#)* 13
 - [Confirm Hybrid Battery Thermal Keep Control Mode State](#)..... 13
 - [Set Hybrid Battery Thermal Keep Control Mode](#)..... 14
- [Seating Position Control ECU Initialization](#) 15
- [Head Unit System Reset](#) 15
- [Dealer Contact Information for Call Dealer Head Unit Function](#)* 15
- [Navigation — Set Date & Time by GPS](#)..... 15

*If applicable.

2026 Prius and Prius PHV Pre-Delivery Service (PDS)

Warranty Policy

If the need for additional repairs or adjustment is noted during PDS, the required service should be performed under warranty. Reimbursement will be managed under the warranty policy.

The Warranty Policy and Procedures Manual requires that you maintain the completed Check Sheet in the customer's file. If you cannot produce a completed form for each retailed vehicle upon TMS and/or Region/Distributor audit, the PDS payment amount will be subject to debit.

An additional Repair Order completed in conjunction with normal PDS MUST have time punch/flags for service. If multiple repairs are performed, separate time flags MUST be punched for each repair.

Warranty Information

OP CODE	DESCRIPTION	MODEL	TIME	OFP	T1	T2
001013	Pre-Delivery Service (PDS)	Prius	1.6	-	-	-
		Prius PHV				

Required Tools & Equipment

REQUIRED EQUIPMENT	SUPPLIER	PART NUMBER	QTY
Techstream ADVi*	ADE	TSADVUNITECP	1
Techstream Lite		TSLP3DLR01	
Techstream Lite (Green Cable)		TSLP2DLR01	

*Essential SST.

NOTE

- Only ONE of the Techstream units listed above is required.
- GTS+ software version 2026.01.003.02 or later is required.
- Additional Techstream units may be ordered by calling Approved Dealer Equipment (ADE) at 1-800-368-6787 or by visiting *TIS – Diagnostics – Tools & Equipment – Techstream Order Portal*.

2026 Prius and Prius PHV Pre-Delivery Service (PDS)

D/C Cut Fuse Installation

Check the location of the D/C Cut fuse (30A). It may have been removed at the assembly plant and temporarily stored in the blank space of the relay block in the engine compartment to minimize battery discharge during transportation and storage.

- If the D/C Cut fuse (30A) is still in its original location in the relay block, proceed with performing a Health Check using GTS+.
- If the D/C Cut fuse (30A) is NOT in its original location, it is necessary to remove the D/C Cut fuse (30A) from the blank space in the relay block and reinstall it to its original location as shown in Figure 1. After installation, confirm ALL related DTCs are cleared.

Figure 1.

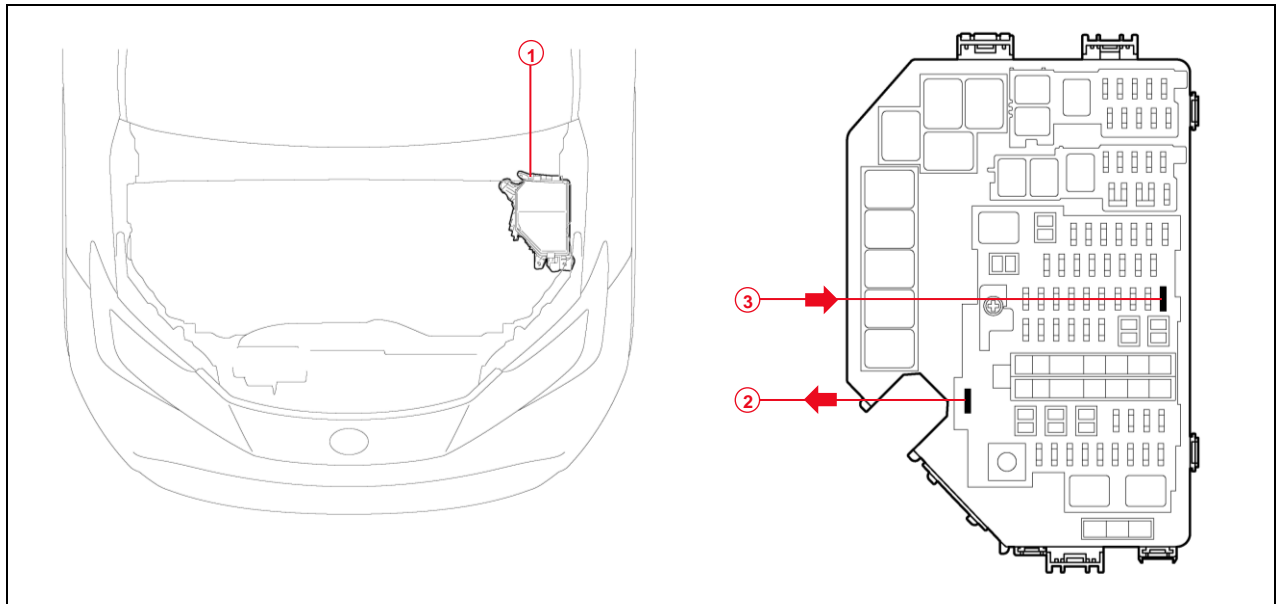

1	Relay Block
2	Remove the D/C Cut Fuse (30A) (Blank Space)

3	Install the D/C Cut Fuse (30A) (Original Location)
----------	---

NOTE

- With the D/C Cut fuse (30A) removed, if ANY DTCs are detected when the ignition is turned ON during transportation, use GTS+ to clear ALL DTCs AFTER ensuring that there are NO malfunctions.
- While the vehicle is stored at the dealership, disconnect the negative (-) battery terminal to prevent battery discharge. Refer to [T-SB-0005-26](#), *Battery Inspection and Maintenance During PDS*, for battery maintenance information.

2026 Prius and Prius PHV Pre-Delivery Service (PDS)

Front License Plate and Mounting Bracket Installation

The front license plate bracket and two self-tapping screws are loaded in the vehicle at the assembly plant. Follow this procedure to install the front license plate bracket and front license plate in states where it is required by law.

- Align holes "A" of the mounting bracket with the dimples on the front bumper cover and mark the location of holes "B" on the front bumper cover.

NOTE

- Holes "A" are used for installation of the mounting bracket to the front bumper cover.
- Holes "B" are used for the installation of the front license plate to the mounting bracket.

Figure 2.

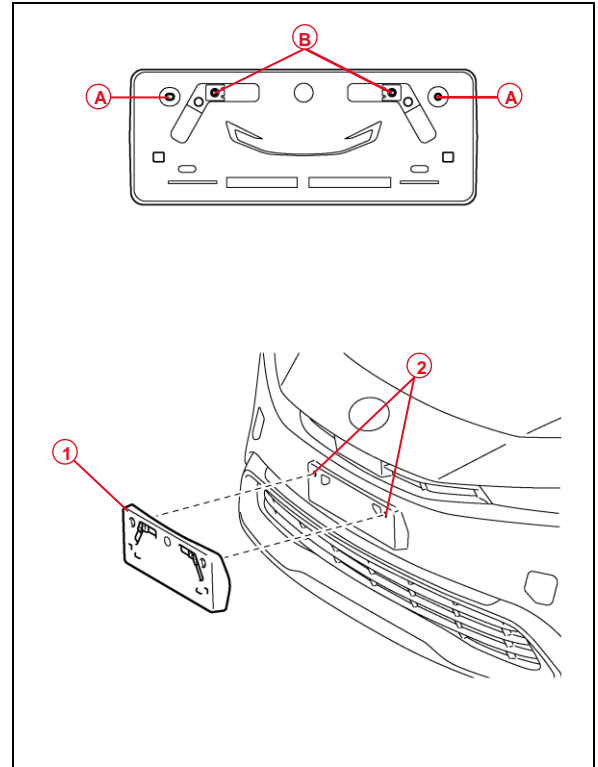

A	Holes "A" for Mounting Bracket
B	Holes "B" for Front License Plate
1	Mounting Bracket
2	Dimples

2026 Prius and Prius PHV Pre-Delivery Service (PDS)

Front License Plate and Mounting Bracket Installation (continued)

2. Create two oval relief holes on the front bumper cover at the marks shown in the figure below to prevent the front license plate mounting bracket from contacting the front bumper.

NOTICE

Do NOT pre-drill holes in the dimples.

Figure 3.

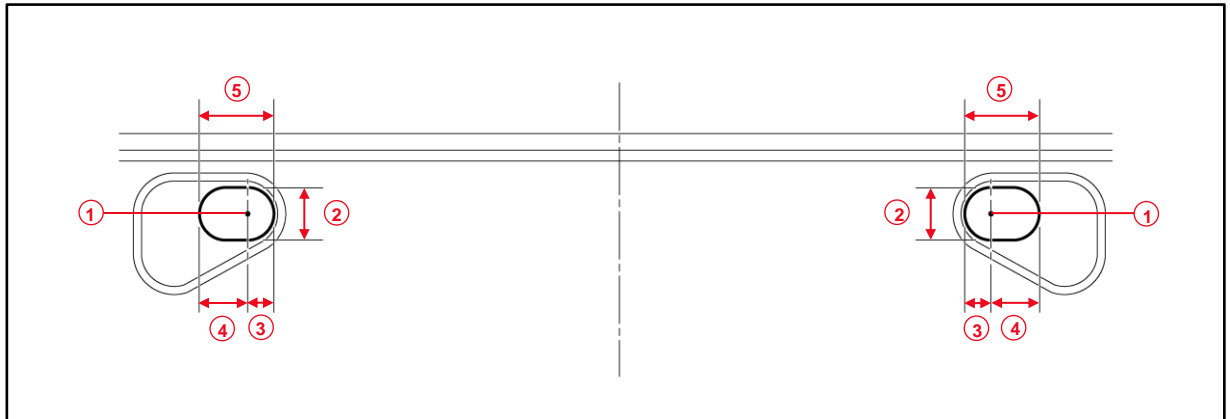

1	Mark
2	12 mm (0.47 in.)
3	6 mm (0.24 in.)

4	11 mm (0.43 in.)
5	17 mm (0.67 in.)

2026 Prius and Prius PHV Pre-Delivery Service (PDS)

Front License Plate and Mounting Bracket Installation (continued)

3. Install the mounting bracket to the front bumper by attaching the two self-tapping screws into the dimples.

NOTICE

Do NOT overtighten the self-tapping screws.

Figure 4.

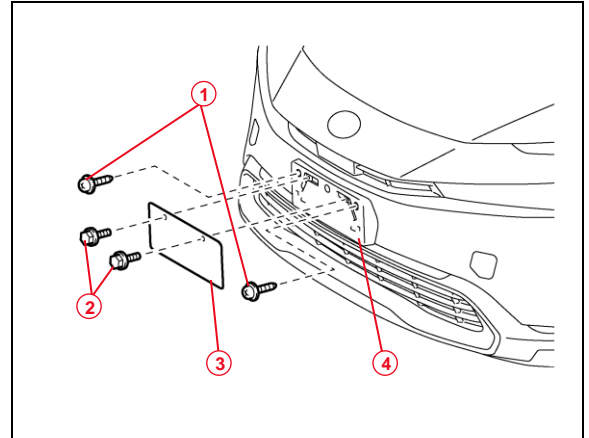

1	Self-tapping Screws
2	Bolts
3	Front License Plate
4	Mounting Bracket

4. Install the front license plate to the mounting bracket using two noncorroding bolts with the following dimensions:

Length: 15.0 mm (0.59 in.)

Diameter: 6.0 mm (0.24 in.)

Figure 5.

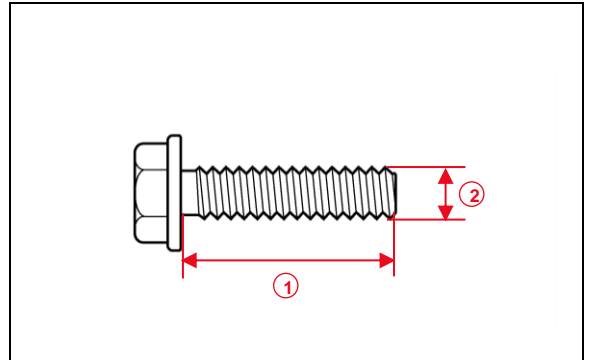

1	Length
2	Diameter

2026 Prius and Prius PHV Pre-Delivery Service (PDS)

Front and Rear Emergency Towing Eyelet Removal and Hole Cover Installation

1. Remove the front and rear emergency towing eyelets from the front and rear bumpers by turning them counterclockwise.

NOTE

If it is difficult to loosen the emergency towing eyelets, use a steel bar.

Figure 6.

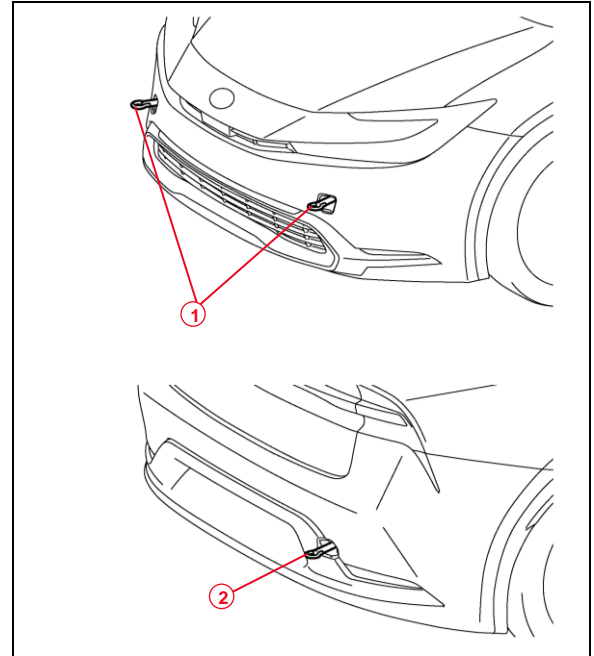

1	Front Emergency Towing Eyelets
2	Rear Emergency Towing Eyelet

2026 Prius and Prius PHV Pre-Delivery Service (PDS)

Front and Rear Emergency Towing Eyelet Removal and Hole Cover Installation (continued)

- Place one of the removed emergency towing eyelets into the luggage tray in the luggage compartment.

NOTE

Dispose of the other removed emergency towing eyelets.

Figure 7.

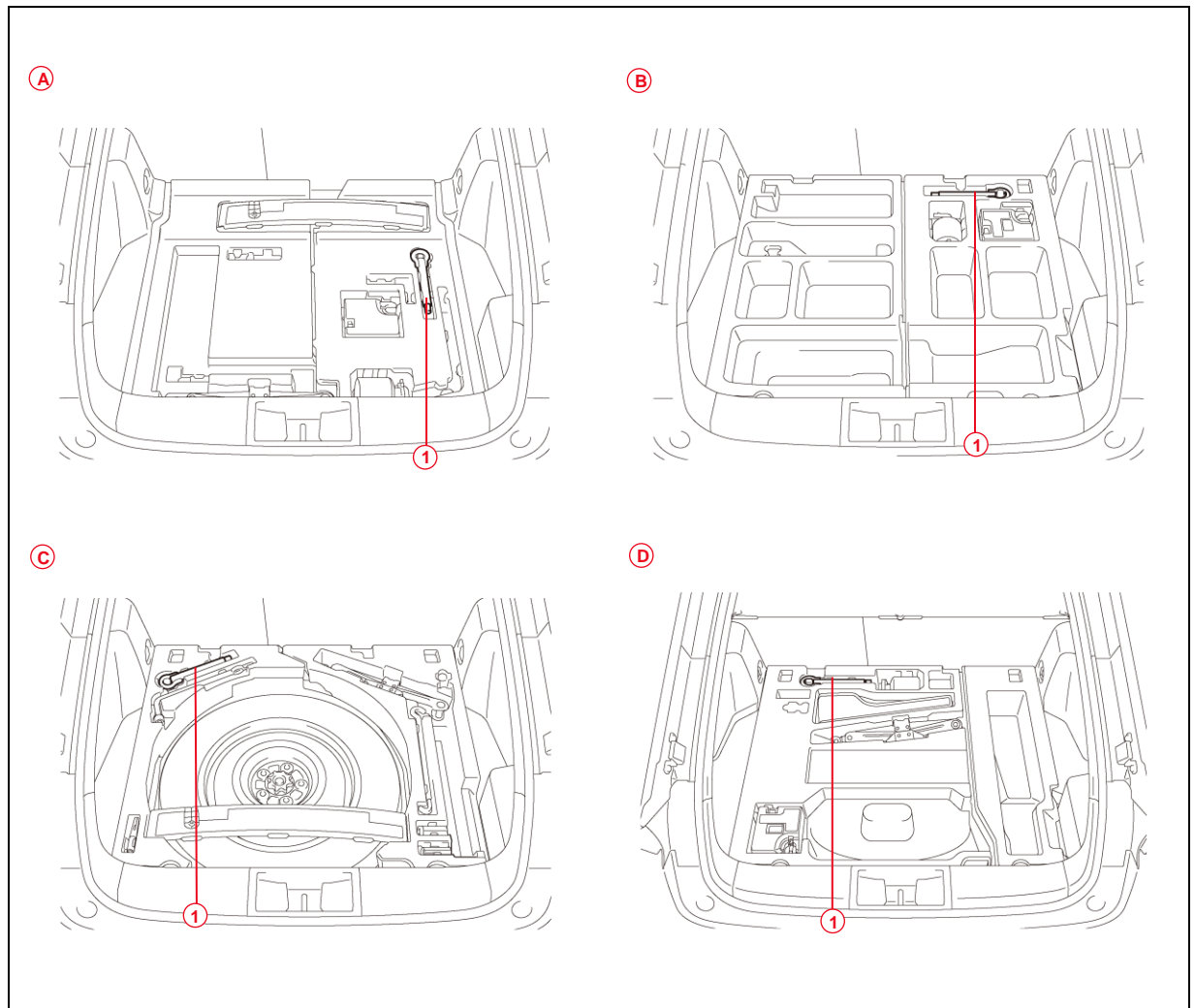

A	Type A
B	Type B
C	Type C

D	Type D
1	Emergency Towing Eyelet

2026 Prius and Prius PHV Pre-Delivery Service (PDS)

Front and Rear Emergency Towing Eyelet Removal and Hole Cover Installation (continued)

3. Install the front and rear emergency towing eyelet hole covers, which are stored in the glove compartment, onto the front and rear bumpers.

- A. Insert the arrow-shaped part "A" of the front emergency towing eyelet hole covers into eyelet hole "B" as shown.

- B. Install the front and rear emergency towing eyelet hole covers into the holes of the front and rear bumper.

NOTE

Make sure the front emergency towing eyelet cover is installed in the front, and the rear emergency towing eyelet cover is installed in the rear.

Figure 8.

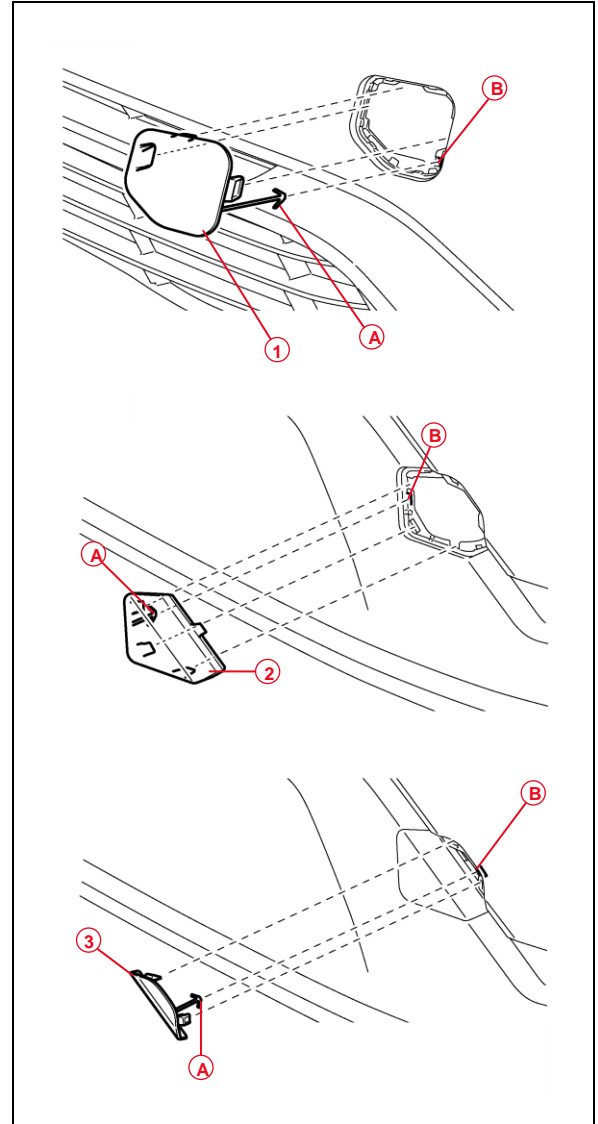

A	Arrow-shaped Part
B	Eyelet Hole
1	Front Emergency Towing Eyelet Hole Cover
2	Rear No. 1 Emergency Towing Eyelet Hole Cover
3	Rear No. 2 Emergency Towing Eyelet Hole Cover

2026 Prius and Prius PHV Pre-Delivery Service (PDS)

Power Back Door Initialization

Refer to the applicable Repair Manual for the power back door initialization procedure.

- [2026](#) Prius and Prius PHV:

Vehicle Exterior – Door / Hatch – Back Door Closer ECU – Initialization

Tire Pressure Warning System (TPWS) Initialization

Refer to the applicable Repair Manual for the TPWS initialization procedure.

- [2026](#) Prius and Prius PHV:

Suspension – Tire Pressure Monitoring – Tire Pressure Warning Receiver – Initialization

NOTE

- To adjust the tire pressure correctly when the outside temperature is significantly colder than shop temperature, perform a Health Check using GTS+ and select the compensation tire pressure checkbox. Compensation pressures will display on the Health Check results screen. Adjust the tire pressure when the tires are cold.
- This model has four TPWS sensors.

2026 Prius and Prius PHV Pre-Delivery Service (PDS)

Enable Hybrid Battery Thermal Keep Control Mode (Prius PHV Only)

The HV/EV battery may be frozen in extremely cold areas. As a result, the HV/EV battery may become excessively weak, and the system may NOT be able to be started. By enabling Hybrid Battery Thermal Keep Control Mode, it is possible to warm the HV/EV battery and maintain its current temperature in order to prevent it from becoming excessively weak.

When this mode is set to ON, the timer charging settings are canceled at temperatures of 14°F(-10°C) or lower. Charging will begin immediately when the charging cable is connected to the vehicle.

Table 2. HV/EV Battery Thermal Keep Control Mode

PURPOSE	CONDITION	OPERATION
Prevent HV/EV battery from freezing	Ambient temperature is 14°F(-10°C) or lower	Begins to warm the HV/EV battery to maintain its current temperature when the ambient temperature drops to 14°F(-10°C) or lower when the charging cable is connected to the vehicle.
	Charging cable is connected to vehicle	To prevent the HV/EV battery from freezing when a charging start time is set, when the Hybrid Battery Thermal Keep Mode is enabled, the charging timer will be disabled, and charging will begin immediately when the charging cable is connected to the vehicle.

To enable Hybrid Battery Thermal Keep Control Mode, it is necessary to use GTS+ during PDS at the dealership.

Confirm Hybrid Battery Thermal Keep Control Mode State

1. Connect the Techstream to the DLC3.
2. Turn the power switch IG-ON.
3. Read the Data List on GTS+ software by entering the following menus: *Powertrain – HV Battery – Data List – Hybrid Battery Thermal Keep Control Mode Status.*
4. Check the results by referring to the following table:

Table 3.

TESTER DISPLAY	MEASUREMENT ITEM	RANGE	NORMAL CONDITION
Hybrid Battery Thermal Keep Control Mode Status	Hybrid Battery Thermal Keep Control Mode State	ON or OFF	ON: Enabled OFF: Disabled

2026 Prius and Prius PHV Pre-Delivery Service (PDS)

Enable Hybrid Battery Thermal Keep Control Mode (continued)

Set Hybrid Battery Thermal Keep Control Mode

1. Connect the Techstream to the DLC3.
2. Turn the power switch to IG-ON.
3. Enter the following menus: *Powertrain – HV Battery – Utility – Hybrid Battery Thermal Keep Control Mode.*

Figure 9.

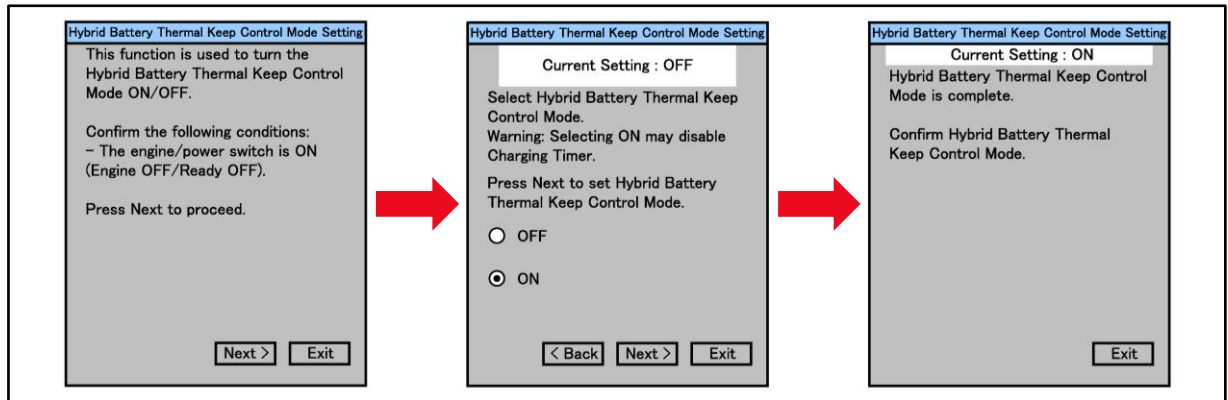

4. Confirm the following message is displayed:

“This function is used to turn the Hybrid Battery Thermal Keep Control Mode ON / OFF.”
5. Confirm that the conditions displayed on the screen are met, and then press Next.

NOTE

The power switch is ON (Ready OFF).

6. Confirm the following message is displayed:

“Select Hybrid Battery Thermal Keep Control Mode.”
7. Select ON and press Next.

NOTICE

Selecting ON may disable the charging timer.

8. Confirm the following message is displayed:

“Hybrid Battery Thermal Keep Control Mode is complete.”

2026 Prius and Prius PHV Pre-Delivery Service (PDS)

Seating Position Control ECU Initialization

Refer to the applicable Repair Manual for the seating position control ECU initialization procedure (procedure 2).

- [2026](#) Prius and Prius PHV:
Vehicle Interior – Seat – Front Power Seat Control System (w/ Memory) – Registration

Head Unit System Reset

Prior to vehicle delivery, confirm that the welcome screen with language options appears on the head unit display when the ignition is switched to the ON position. There may be instances where the welcome screen with language options may not properly appear on the head unit display.

If the welcome screen showing language options is not displayed, complete the following steps:

1. Select the Settings option (gear icon).
2. Scroll down and select the Info & Security option.
3. The System Reset dialogue box will appear. Select Reset to confirm the resetting of the system.
4. Confirm that the welcome screen with language options is now displayed.

Dealer Contact Information for Call Dealer Head Unit Function (Premium Audio Only)

Refer to the *Multimedia System Owner's Manual* to add dealer contact information.

- [2026](#) Prius:
Section 2-8 Vehicle Settings – Setting dealer information
- [2026](#) Prius PHV:
Section 2-8 Vehicle Settings – Setting dealer information

Navigation — Set Date & Time by GPS

Prior to vehicle delivery, it is necessary to turn the Set date & time by GPS setting to the ON position.

1. Turn the engine switch (power switch) to the ON position (ON mode).
2. Navigate the following menus in the head unit: *Settings – General – Date & Time – Set Date & Time by GPS*.
3. Ensure the Set date & time by GPS function is set to the ON position.