

JLRTB02149NAS
TECHNICAL BULLETIN
19 MAY 2026



© Jaguar Land Rover North America, LLC

NOTE: The information in Technical Bulletins is intended for use by trained, professional Technicians with the knowledge, tools, and equipment required to do the job properly and safely. It informs these Technicians of conditions that may occur on some vehicles, or provides information that could assist in proper vehicle service. The procedures should not be performed by 'do-it-yourselfers'. If you are not a Retailer, do not assume that a condition described affects your vehicle. Contact an authorized Land Rover service facility to determine whether this bulletin applies to a specific vehicle.

INFORMATION

SECTION:

310-01

SUBJECT/CONCERN:

Fuel Vapor Smell in Passenger Compartment - Further Enhancements

AFFECTED VEHICLE RANGE:

MODEL:	MODEL YEAR:	ASSEMBLY PLANT:	APPLICABILITY:
Range Rover (LK)	2022 Onwards	Solihull	INGENIUM I6 3.0L Petrol/V8 T/C 4.4L Petrol
Range Rover Sport (L1)	2023 Onwards	Solihull	INGENIUM I6 3.0L Petrol/V8 T/C 4.4L Petrol

MARKETS:

NORTH AMERICA

CONDITION SUMMARY:**NOTES:**

- This new bulletin supersedes JLRTB02112NASv2 with immediate effect.
- All repair actions previously defined in JLRTB02112NASv2 remain valid; however, they are now incorporated within this updated bulletin along with additional service repair enhancements.
- If the vehicle has not previously completed JLRTB02112NASv2 or is not equipped with a fuel tank insulation kit, complete the full repair procedure as defined in this bulletin, including the original repair element (3 piece undershields and fuel tank insulation) and the new service enhancement.
- If the vehicle has already completed JLRTB02112NASv2, the previously completed repair element (3 piece undershields and fuel tank insulation) must not be repeated. Technicians must only complete the new service repair enhancement instructions included in this bulletin.

SITUATION:

The smell of fuel vapor is evident within the passenger compartment during high ambient temperatures.

CAUSE:

Increased heat transfer to the fuel tank and fuel, causing increased vapor generation.
Suggested customer concern code - **MB6**

ACTION:

Follow the instruction(s) below.

**The following applies to:**

All Vehicles

PARTS:**NOTES:**

- Although the majority of service enhancement parts are common across all derivatives, the parts required for each vehicle will vary depending on the vehicle specification. The parts list below is organized by vehicle specification, and a combination of parts will be required. Carefully review the list, paying close attention to derivative subheadings, and order only the parts applicable to the vehicle's specification.
- *An allowance equivalent to £2.50 Sterling has been allocated for locally source suitable 5 mm rivets.

PART NUMBER	DESCRIPTION	QUANTITY
All Derivatives		
527123623	Startup battery upper housing - Inner deflector	1
527123625	Startup battery upper housing - Outer deflector	1
527123624	Startup battery lower housing - Inner deflector	1
527123626	Startup battery lower housing - Outer deflector	1
LR028396	Startup battery lower housing - Outer deflector - Bolt	1
527123616	Fuel tank heatshield	1
527123607	Left upper heatshield	1
527123617	Rear driveshaft heatshield	1
527123622	Driveshaft universal joint heatshield	1
568123621	Rear HVAC drain	1
AYP500110	Heatshield bolt	6
LR092696	Rear driveshaft bolt	6
LR034506	O-ring kit	1

PART NUMBER	DESCRIPTION	QUANTITY
TYF500020	Rear driveshaft link washer	3
*ZZZ001	Suitable 5 mm rivets x8	£2.50
Range Rover Sport and Short Wheelbase (SWB) Range Rover Vehicles - All engine derivatives		
527123608	Rear left upper heatshield	1
527123620	Left center bearing heatshield	1
527123618	Right center bearing heatshield	1
527123610	Right heatshield	1
Long Wheelbase Range Rover Vehicles - All engine derivatives		
527123609	Rear left upper heatshield	1
527123621	Left center bearing heatshield	1
527123619	Right center bearing heatshield	1
527123611	Right heatshield	1
RYH500310	Heatshield nut	1
Range Rover Sport and SWB Range Rover - V8 T/C 4.4L (NC10/NC11) and 2025 model year Onwards INGENIUM I6 3.0L petrol		
527123612	Left heatshield	1
LWB Range Rover - V8 T/C 4.4L (NC10/NC11) and 2025 model year INGENIUM I6 3.0L petrol		
527123613	Left heatshield	1
Range Rover Sport and SWB Range Rover - 2022 model year to 2024 model year INGENIUM I6 3.0L petrol		
527123614	Left heatshield	1
LWB Range Rover - 2022 model year to 2024 model year INGENIUM I6 3.0L petrol		
527123615	Left heatshield	1
V8 T/C 4.4L (NC10) petrol vehicles - All models and wheelbase derivatives		
527123627	Left fuel tank heatshield deflector	1
LR090632	Left fuel tank heatshield deflector - Bolt	3
527123641	Left In-fill heatshield	1
LR184931	Right transfer case heatshield	1

**The following applies to:**

Vehicles That Require Fuel Tank Insulation and 3 Piece Transmission Undershields

PARTS:**NOTES:**

- A new 3 piece transmission undershield must be installed to vehicles that enter the JLR retailer / authorized repairer installed with a single piece transmission undershield.
- ****An allowance equivalent to £10.00 Sterling has been allocated to locally source reinforced aluminum tape.**

PART NUMBER	DESCRIPTION	QUANTITY
All Derivatives		
**ZZZ001	Reinforced aluminum tape	£10.00
LR181646	Fuel tank insulation kit	1
LR117476	Fuel pump O-ring seal	1
LR092696	Rear driveshaft bolt	6
LR034506	O-ring kit	1
TYF500020	Rear driveshaft link washer	3
V8 T/C 4.4L Petrol (NC10/NC11) Vehicles		
LR179491	Exhaust clamp	2
LR189116	Transmission undershield - Left	1
LR189115	Transmission undershield - Right	1
LR189114	Transmission undershield - Centre	1
INGENIUM I6 3.0L Petrol Vehicles		
LR181089	Exhaust clamp	1
LR158254	M6 x 24 mm bolt	1

PART NUMBER	DESCRIPTION	QUANTITY
LR180955	M6 x 21 mm bolt	1
523123684	Transmission undershield	1
523123683	Transmission undershield	1
523123685	Transmission undershield - Center	1

WARRANTY:**NOTES:**

- Repair procedures are under constant review, and therefore times are subject to change; those quoted here must be taken as guidance only. Use TOPIx to obtain the latest repair time.
- The JLR claims submission system requires the use of causal part numbers. Labor only claims must show the causal part number with a quantity of zero.

DESCRIPTION	SRO	TIME (HOURS)	CONDITION CODE	CAUSAL PART
Range Rover - INGENIUM I6 3.0L Petrol - JLRTB Complete Service Instruction A (Including Fuel Tank Insulation Kit) and B - Without Executive Seats	99.04.13.14	6.4	N/A	LR157036
Range Rover - V8 T/C 4.4L Petrol (NC10) - JLRTB Complete Service Instruction A (Including Fuel Tank Insulation Kit) and B - Without Executive Seats	99.04.13.14	7.1	N/A	LR157036
Range Rover - V8 T/C 4.4L Petrol (NC11) - JLRTB Complete Service Instruction A (Including Fuel Tank Insulation Kit) and B - Without Executive Seats	99.04.13.14	7.0	N/A	LR157036
Range Rover Sport - INGENIUM I6 3.0L Petrol - JLRTB Complete Service Instruction A (Including Fuel Tank Insulation Kit) and B	99.04.13.14	6.3	N/A	LR157036
Range Rover Sport - V8 T/C 4.4L Petrol (NC10) - JLRTB Complete Service Instruction A (Including Fuel Tank Insulation Kit) and B	99.04.13.14	6.6	N/A	LR157036

DESCRIPTION	SRO	TIME (HOURS)	CONDITION CODE	CAUSAL PART
Range Rover Sport Core - V8 T/C 4.4L Petrol (NC11) - JLRTB Complete Service Instruction A (Including Fuel Tank Insulation Kit) and B	99.04.13.14	6.0	N/A	LR157036
Range Rover Sport SV - V8 T/C 4.4L Petrol (NC11) - JLRTB Complete Service Instruction A (Including Fuel Tank Insulation Kit) and B	99.04.13.14	6.5	N/A	LR157036
Range Rover - INGENIUM I6 3.0L Petrol - JLRTB Complete Service Instruction A (Including Fuel Tank Insulation Kit) and B - With Executive Seats	99.04.13.16	7.1	N/A	LR157036
Range Rover - V8 T/C 4.4L Petrol (NC10) - JLRTB Complete Service Instruction A (Including Fuel Tank Insulation Kit) and B - With Executive Seats	99.04.13.16	7.7	N/A	LR157036
Range Rover - V8 T/C 4.4L Petrol (NC11) - JLRTB Complete Service Instruction A (Including Fuel Tank Insulation Kit) and B - With Executive Seats	99.04.13.16	7.6	N/A	LR157036
Range Rover - INGENIUM I6 3.0L Petrol - JLRTB Complete Service Instruction A (Excluding Fuel Tank Insulation Kit) and B	99.04.13.21	4.6	N/A	LR157036
Range Rover - V8 T/C 4.4L Petrol (NC10) - JLRTB Complete Service Instruction A (Excluding Fuel Tank Insulation Kit) and B	99.04.13.21	5.2	N/A	LR157036
Range Rover - V8 T/C 4.4L Petrol (NC11) - JLRTB Complete Service Instruction A (Excluding Fuel Tank Insulation Kit) and B	99.04.13.21	5.1	N/A	LR157036
Range Rover Sport - INGENIUM I6 3.0L Petrol - JLRTB Complete Service Instruction A (Excluding Fuel Tank Insulation Kit) and B	99.04.13.21	4.5	N/A	LR157036
Range Rover Sport - V8 T/C 4.4L Petrol (NC10) - JLRTB Complete Service Instruction A (Excluding Fuel Tank Insulation Kit) and B	99.04.13.21	4.8	N/A	LR157036
Range Rover Sport Core - V8 T/C 4.4L Petrol (NC11) - JLRTB Complete Service Instruction A (Excluding Fuel Tank Insulation Kit) and B	99.04.13.21	4.1	N/A	LR157036

DESCRIPTION	SRO	TIME (HOURS)	CONDITION CODE	CAUSAL PART
Range Rover Sport SV - V8 T/C 4.4L Petrol (NC11) - JLRTB Complete Service Instruction A (Excluding Fuel Tank Insulation Kit) and B	99.04.13.21	4.2	N/A	LR157036

 **NOTE:**

Normal Warranty procedures apply.

SERVICE INFORMATION:

1. If the vehicle has not previously completed JLRTB02112NAS or is not equipped with a fuel tank insulation kit, technicians must complete:
 - Service Instruction A - **All steps**
 - Service Instruction B - Steps applicable to the vehicle specification
2. If the vehicle has previously completed JLRTB02112NAS or was manufactured with a fuel insulation kit, technicians must complete:
 - Service Instruction A - Steps **2 to 16** followed by steps **39 to 71**.
 - Service Instruction B - Steps applicable to the vehicle specification
3. The fuel tank insulation kit is packaged in 2 separate labeled bags. Each bag contains 5 numbered self adhesive insulation pads.
 - The bag with the **GREEN** label contains the insulation pads for the left side of the fuel tank.
 - The bag with the **RED** label contains the insulation pads for the right side of the fuel tank.

SERVICE INSTRUCTION A:**NOTES:**

- **Always review the Service Instruction prior to starting the repair to confirm the correct steps for the vehicle.**
- If the vehicle is equipped with the original single piece transmission undershield it must be removed and discarded. A new 3 piece transmission undershield must be installed.
- Some components shown removed for clarity.
- Some variation in the illustrations may occur, but the essential information is always correct.

All Vehicles**1.** Check the vehicles fuel level.

- If the vehicles fuel level is more than half full, drain the fuel from the fuel tank until the level is under half before continuing to step 2 (see TOPIx Workshop Manual section 310-00: Fuel System - General Information - General Procedures - Fuel Tank Draining).
- If the vehicles fuel level is half full or lower, continue step 2.

2.**NOTE:**

Only discard the transmission undershield, front midfloor undershield and front midfloor undershield bracket if the vehicle is equipped with the original single piece transmission undershield.

Remove the rear driveshaft (see TOPIx Workshop Manual section 205-01: Driveshaft - Removal and Installation - Rear Driveshaft).

- During removal of the rear driveshaft, inspect the transmission undershield, if it is a 1 piece transmission undershield:
 - Discard the transmission undershield when removed.
 - Discard the front midfloor undershield when removed.
 - Discard the front midfloor undershield bracket when removed.

3.

NOTE:

The exhaust system has been removed during the previous step.

Remove the startup battery housing (see TOPIx Workshop Manual section 414-01: Battery, Mounting and Cables - Removal and Installation - Startup Battery Housing).

4.

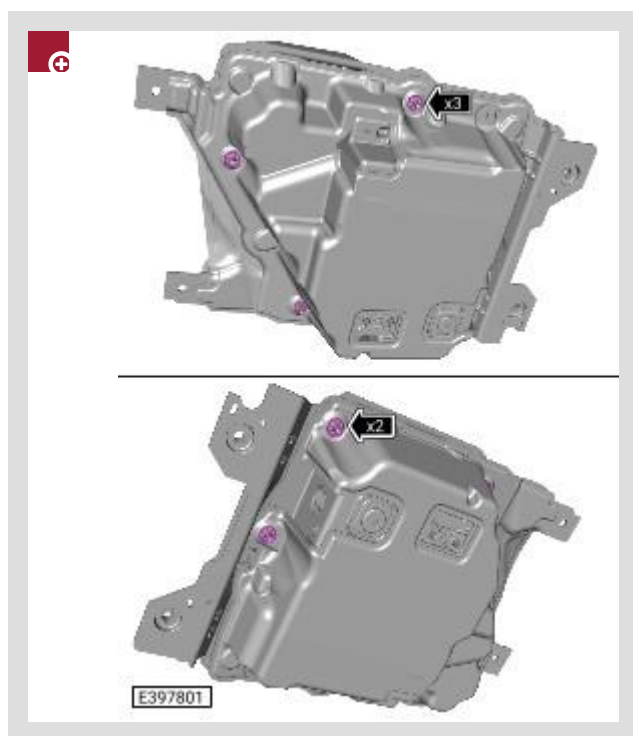

Remove the 5 clips.

5.

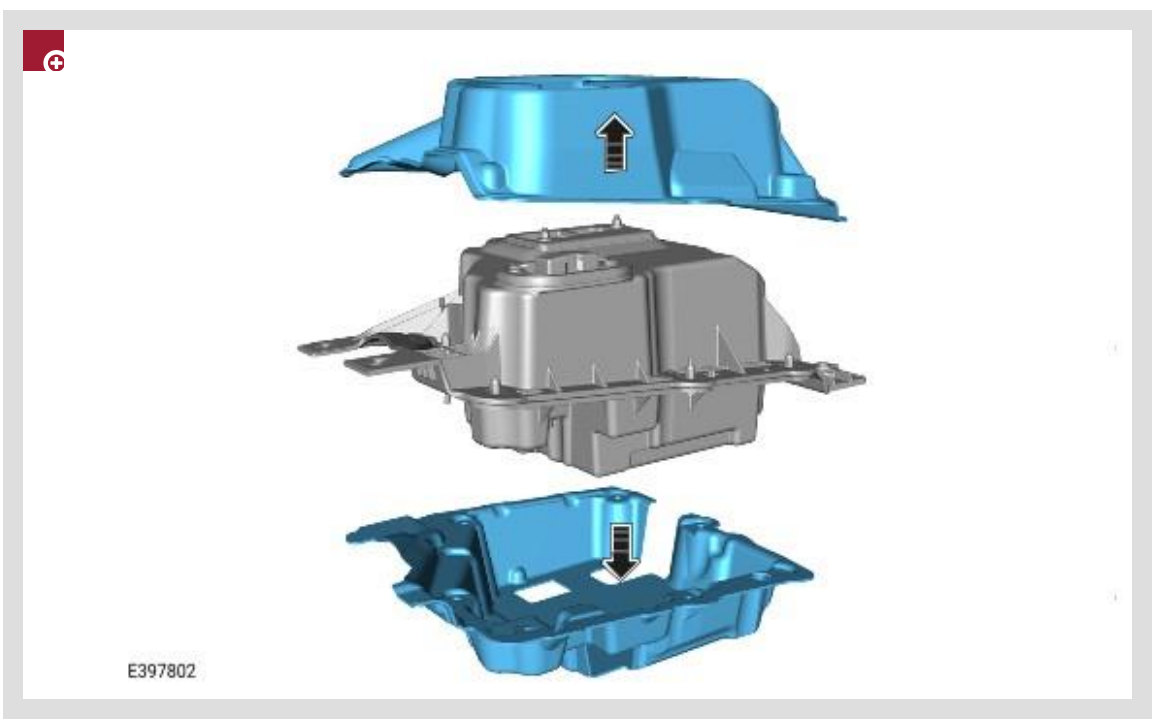

Remove the startup battery housing Noise, Vibration and Harshness (NVH) cover.

6.

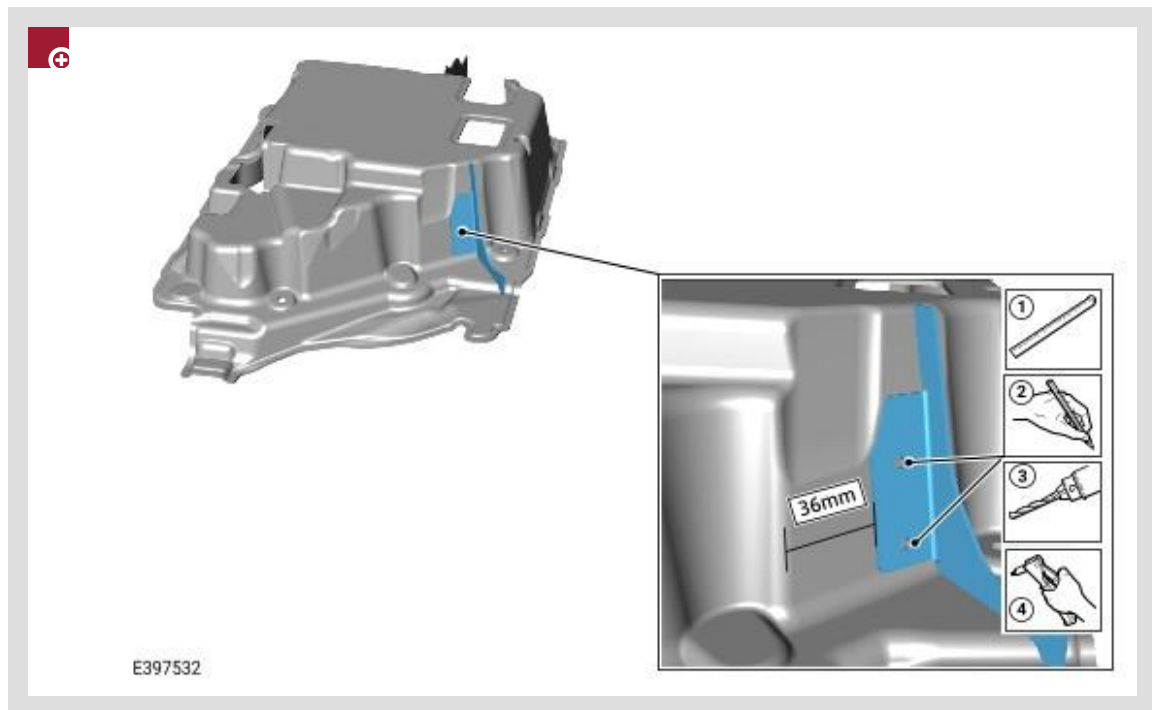

Install the lower startup battery housing NVH inner deflector.

1. **NOTE:**

The bottom of the deflector must be flush with the rim of the upper startup battery housing NVH.

Position the deflector to the measurement shown in the illustration.

2. Mark the holes with a suitable marker.
3. Drill the holes using a 5 mm drill bit.

4. **NOTE:**

The rivets must be installed from the inside of the upper startup battery housing NVH.

Secure the deflector with suitable 5 mm rivets.

7.

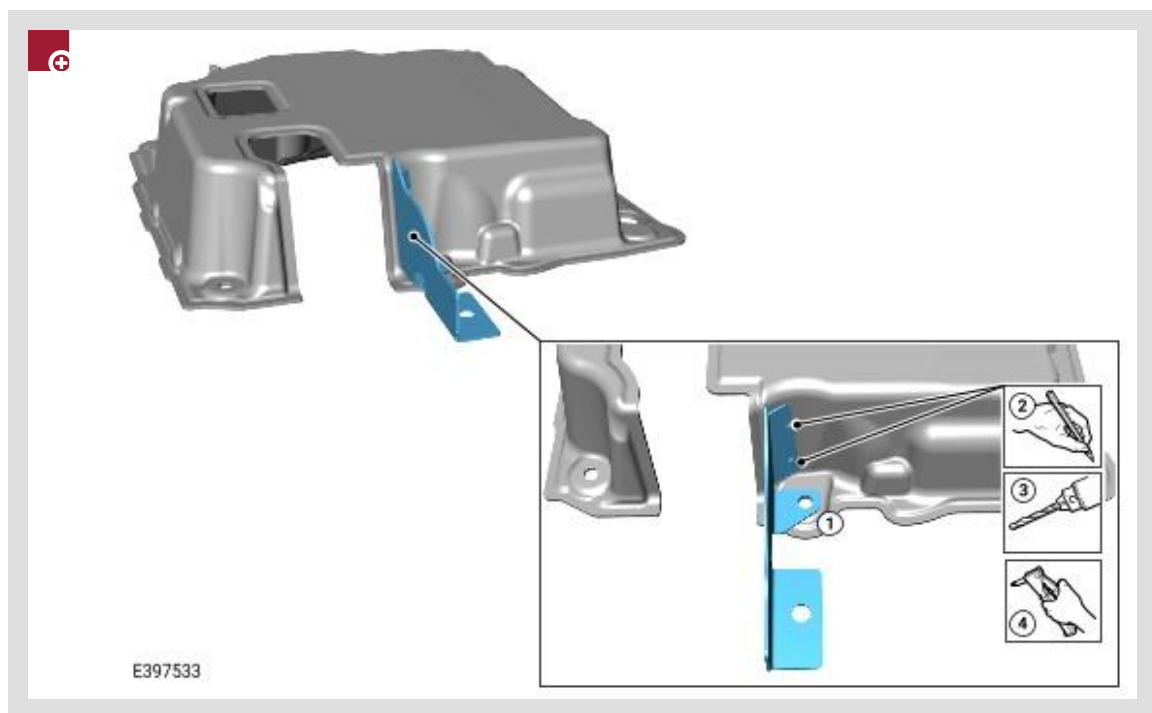

Install the lower startup battery housing **NVH** outer deflector.

1. **NOTE:**

The bottom of the deflector must be flush with the rim of the lower startup battery housing **NVH**.

Align the deflector with the hole in the upper startup battery housing **NVH**, as shown in the illustration.

2. Mark the holes with a suitable marker.

3. Drill the holes using a 5 mm drill bit.

4. **NOTE:**

The rivets must be installed from the inside of the upper startup battery housing **NVH**.

Secure the deflector with suitable 5 mm rivets.

8.

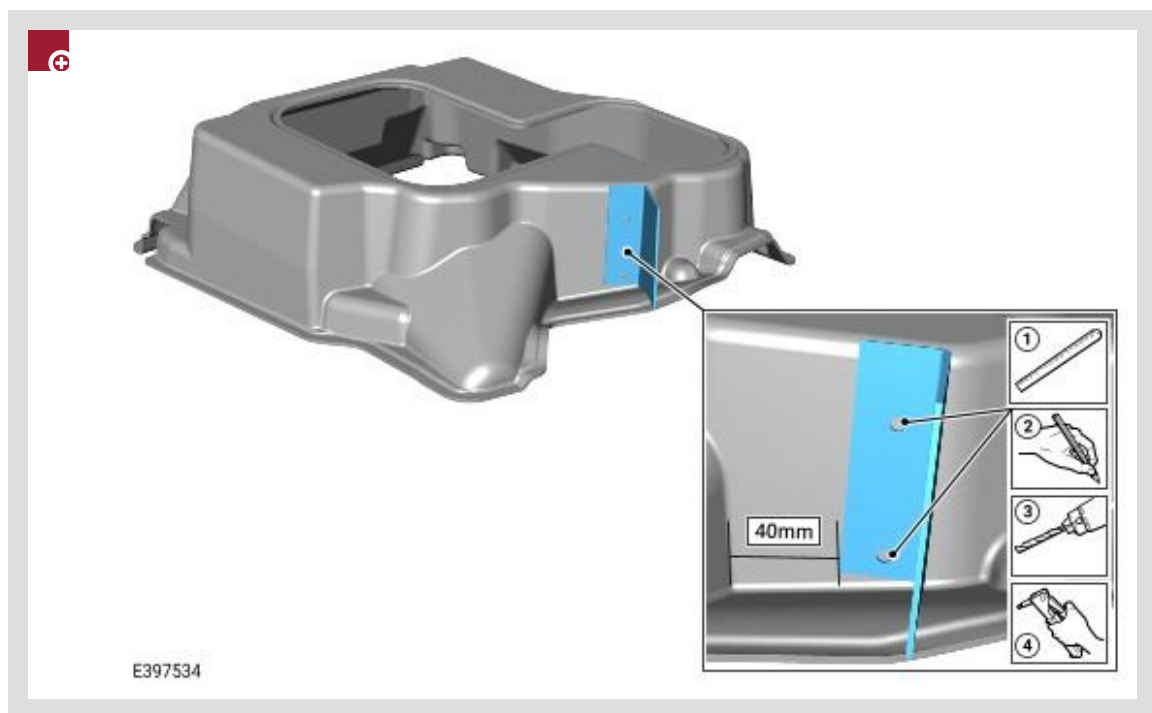

Install the upper startup battery housing **NVH** inner deflector.

1. **NOTE:**

The bottom of the deflector must be flush with the rim of the lower startup battery housing **NVH**.

Position the deflector as per the measurement in the illustration.

2. Mark the holes with a suitable marker.
3. Drill the holes using a 5 mm drill bit.

4. **NOTE:**

The rivets must be installed from the inside of the upper startup battery housing **NVH**.

Secure the deflector with suitable 5 mm rivets.

9.

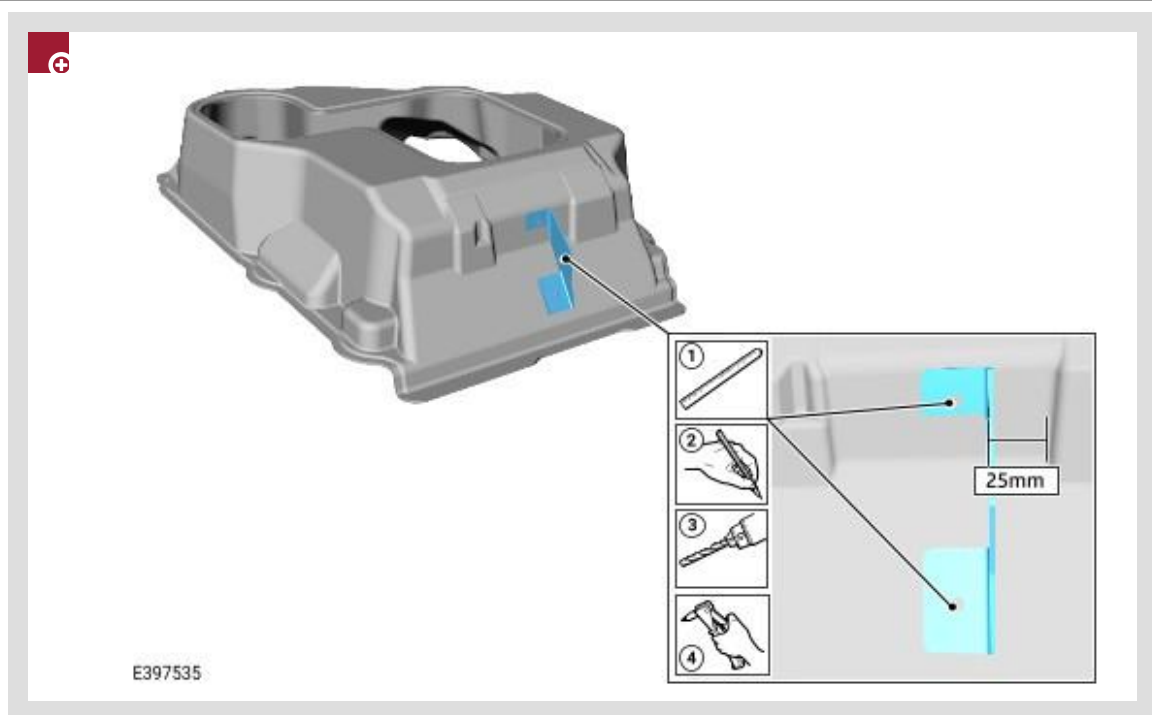

Install the upper startup battery housing **NVH** outer deflector.

1. **NOTE:**

The bottom of the deflector must be flush with the rim of the lower startup battery housing **NVH**.

Position the deflector as per the measurement in the illustration.

2. Mark the holes with a suitable marker.
3. Drill the holes using a 5 mm drill bit.

4. **NOTE:**

The rivets must be installed from the inside of the upper startup battery housing **NVH**.

Secure the deflector with suitable 5 mm rivets.

10.

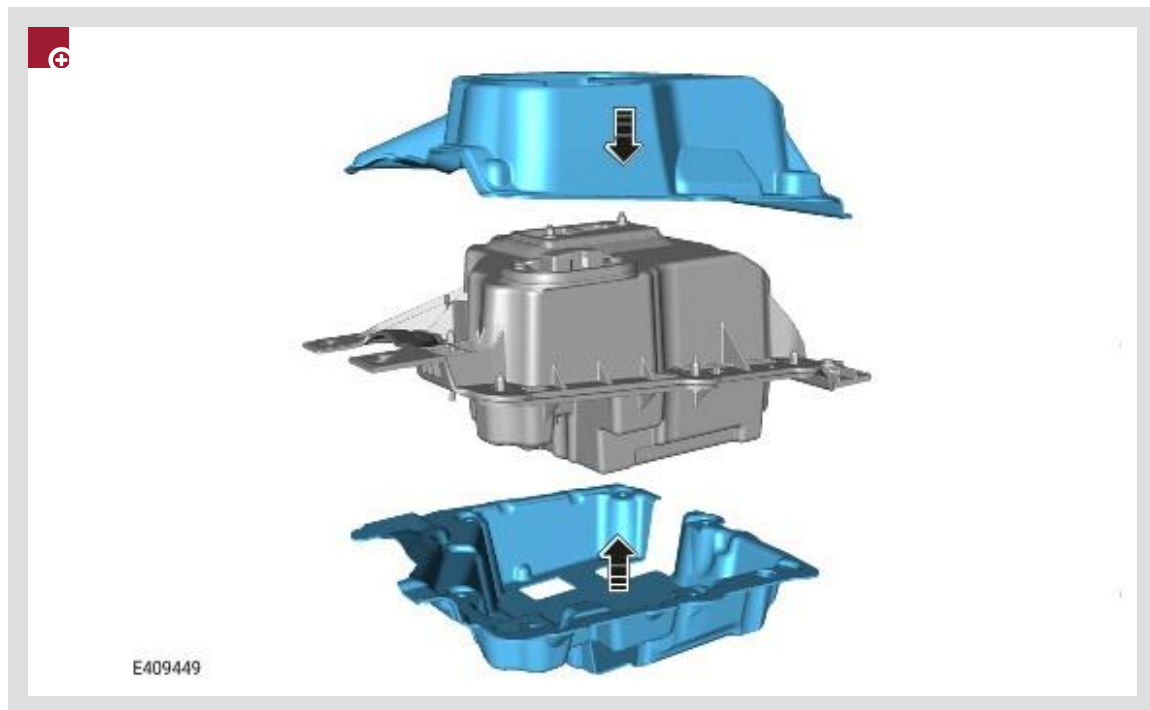

Install the startup battery housing NVH cover.

11.

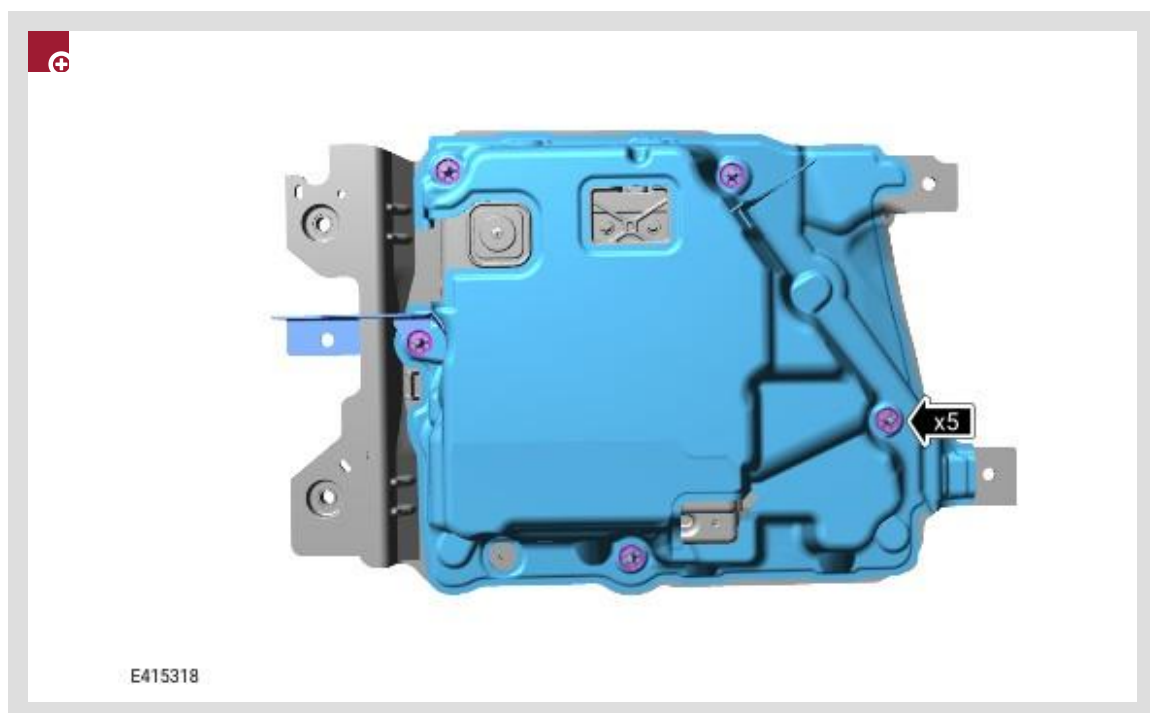

Install the 5 clips.

12.

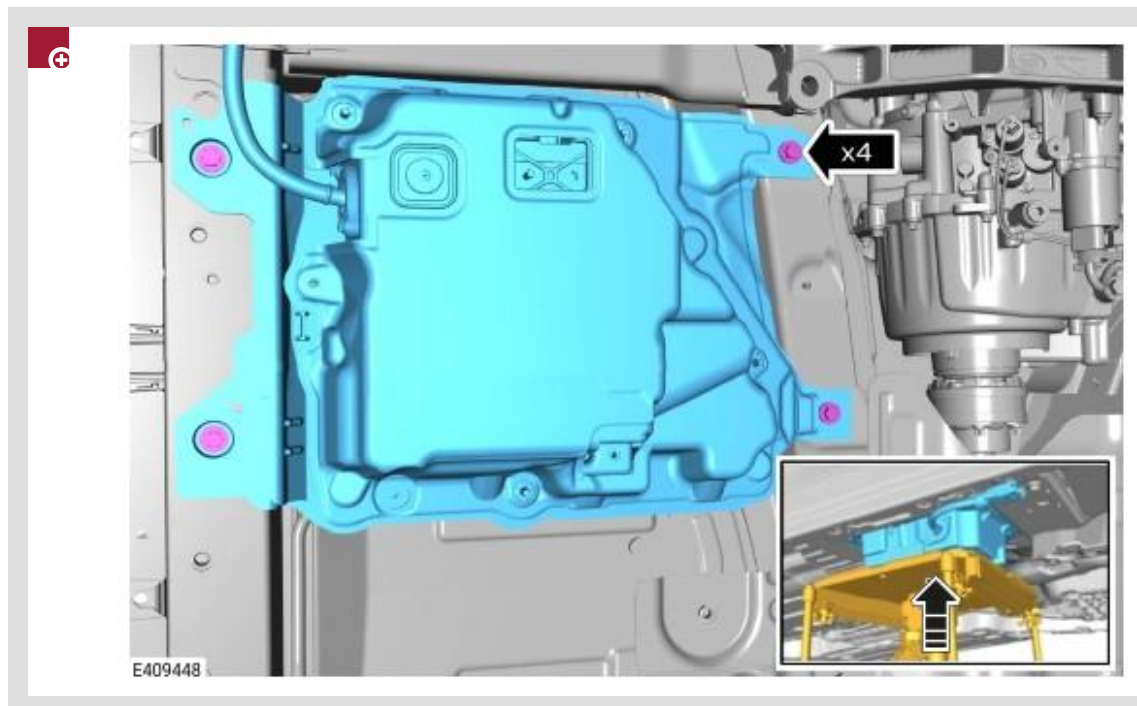

Install the startup battery housing.

- Position a suitable stand below the startup battery housing.
- Install the 4 bolts.
 - Torque: **24Nm**

13.

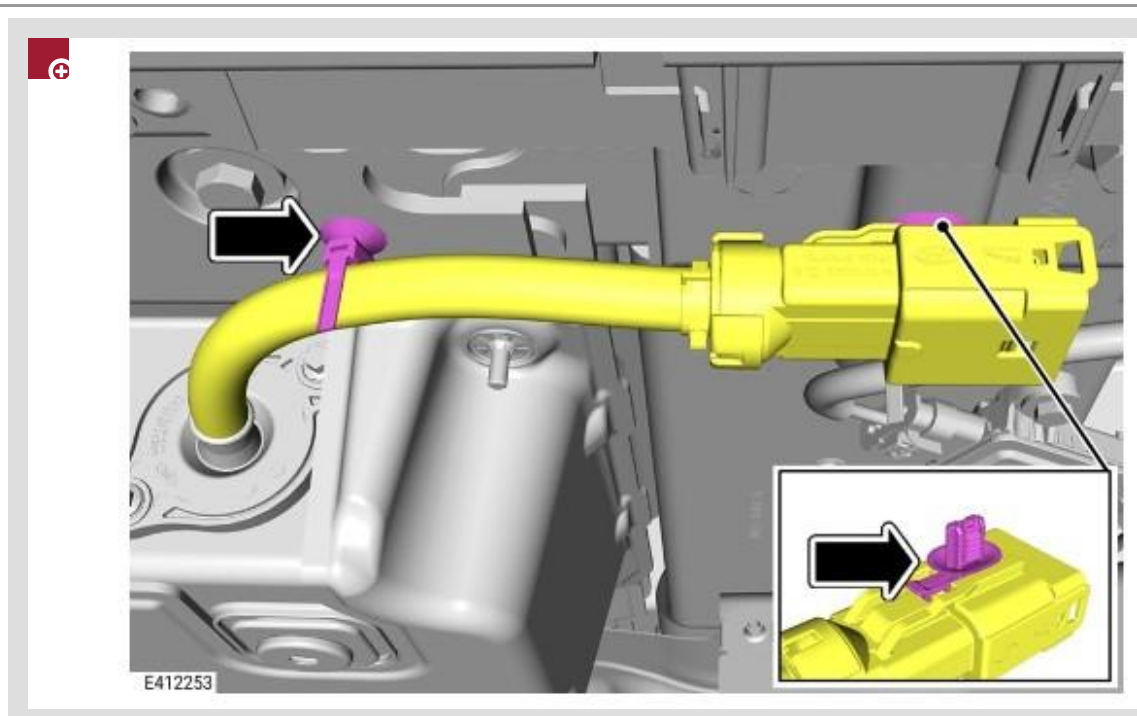

Install the startup battery positive cable electrical connector clip.

- Secure the clip.

14.

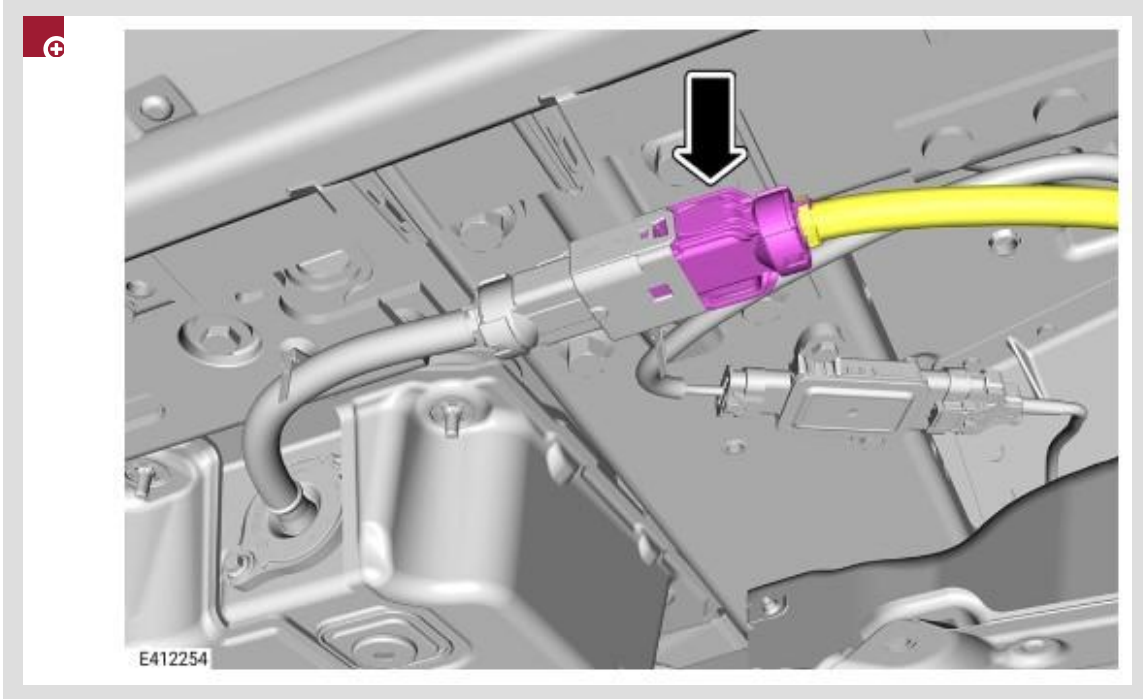

Connect the startup battery positive cable electrical connector.

15.

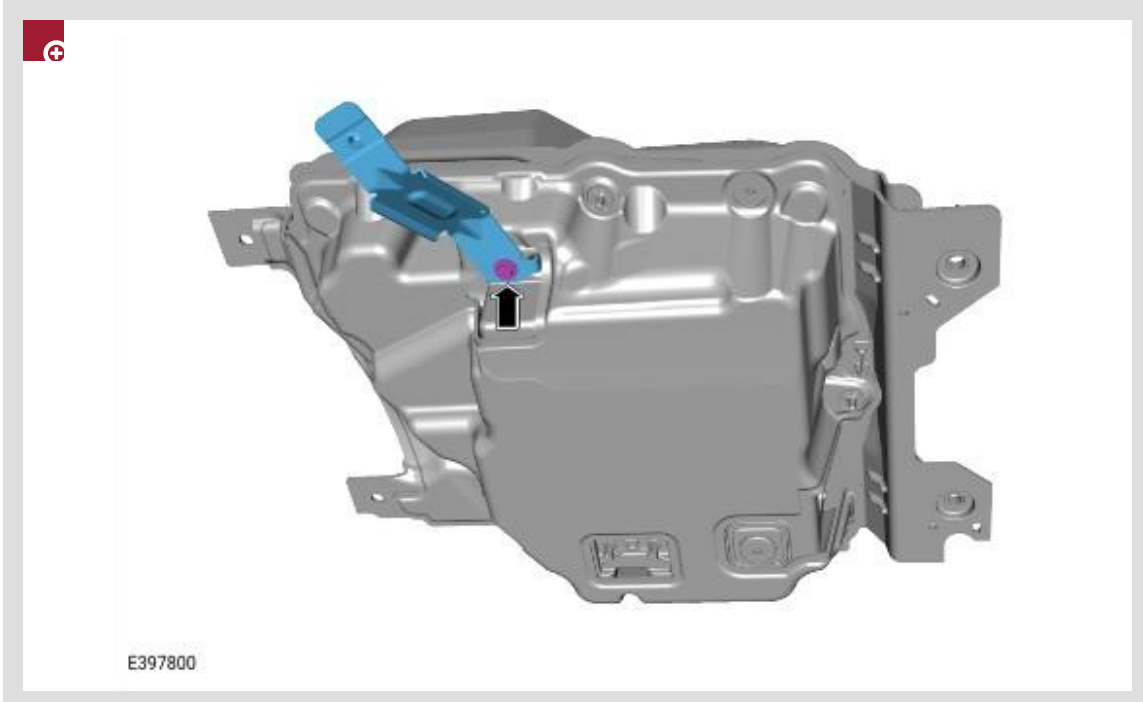

Install the bracket.

- Install the bolt.
 - Torque: **5Nm**

16.

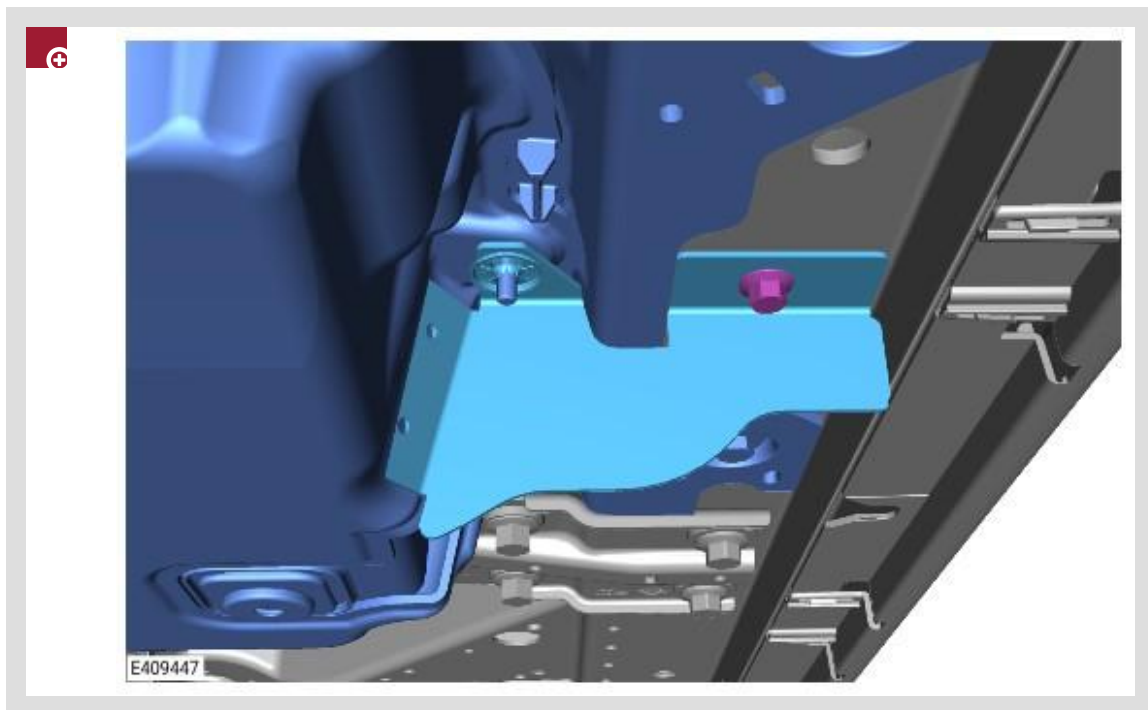

Secure the battery housing to the vehicle body.

▪ **NOTE:**

Apply a small amount of medium strength thread lock to the bolt before installing.

Install the new bolt (LR028396).

- Torque: **15Nm**

Vehicles Without Fuel Tank Insulation Only

NOTES:

- **Some vehicles may have been manufactured with a fuel tank insulation kit.**
- **Some vehicles may have been installed with a fuel tank insulation kit as part of the JLRTB02112 repair.**
- **Only complete steps 17 to 38 if the vehicle is not currently installed with a fuel tank insulation kit.**
- **If the vehicle is already installed with a fuel tank insulation continue to step 39.**

17.

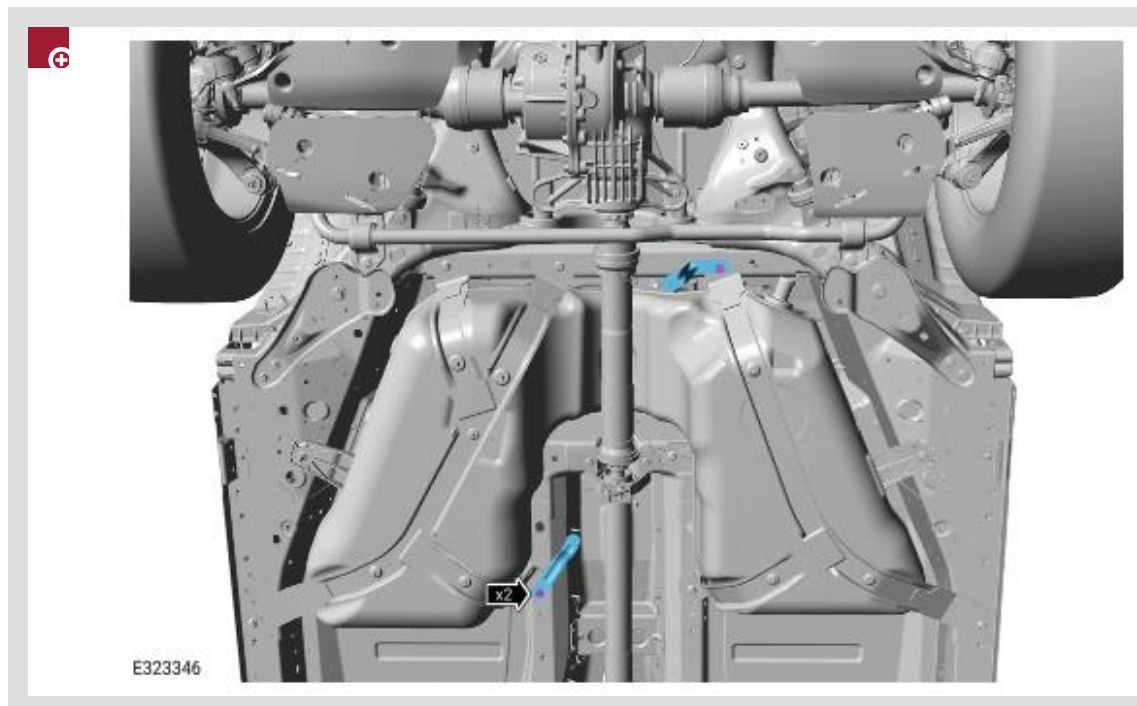

Remove the 2 heatshield supporting brackets.

- Remove the 2 nuts.

18.

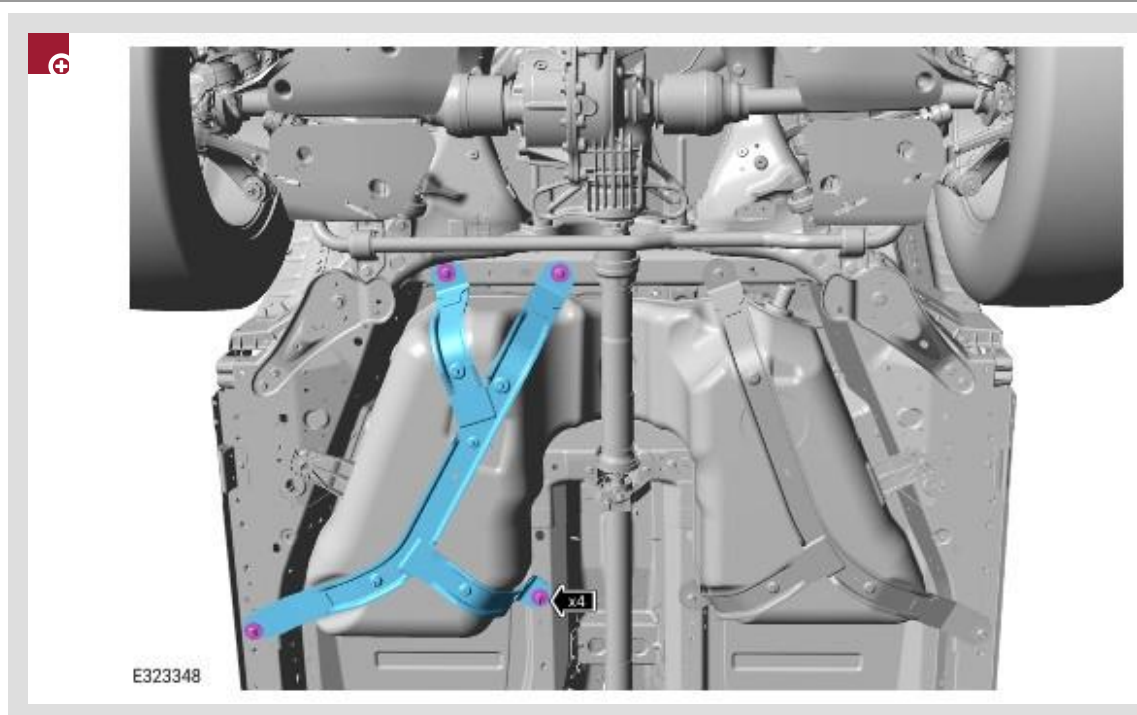

Remove the left fuel tank support strap.

- Remove the 4 bolts.

19.

The fuel tank must be clean and free from contamination before continuing to the next step.

20.

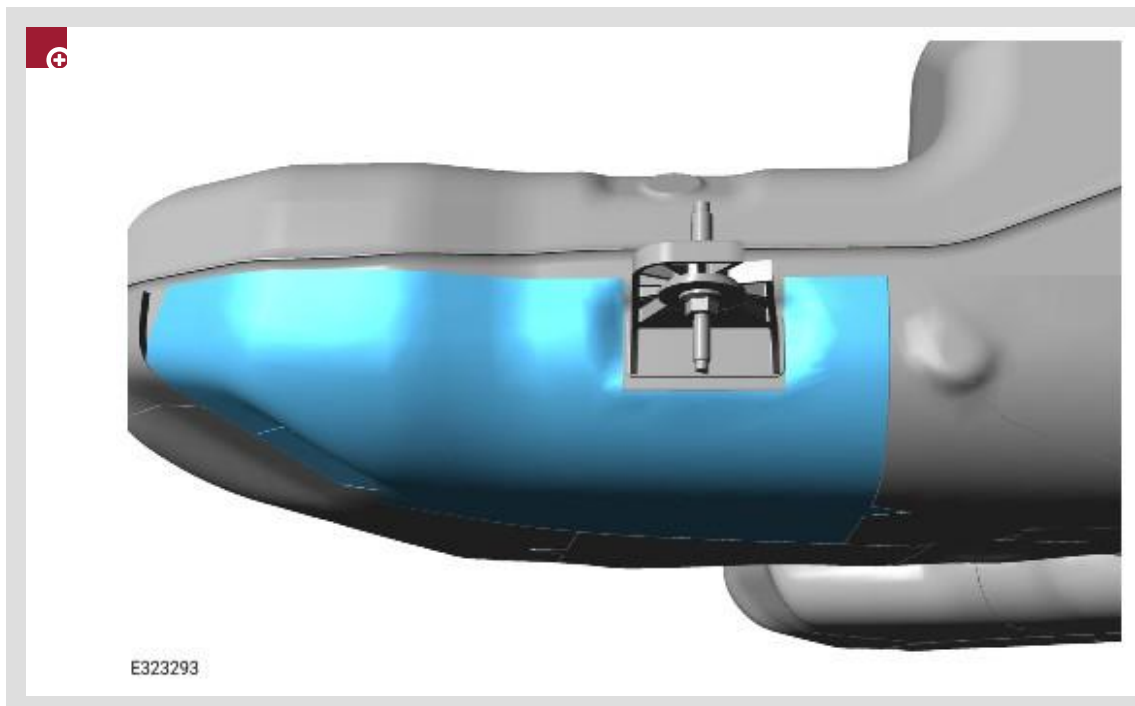

Apply adhesive insulation pad **L01** to the left side of the fuel tank in the location shown in the illustration.

21.

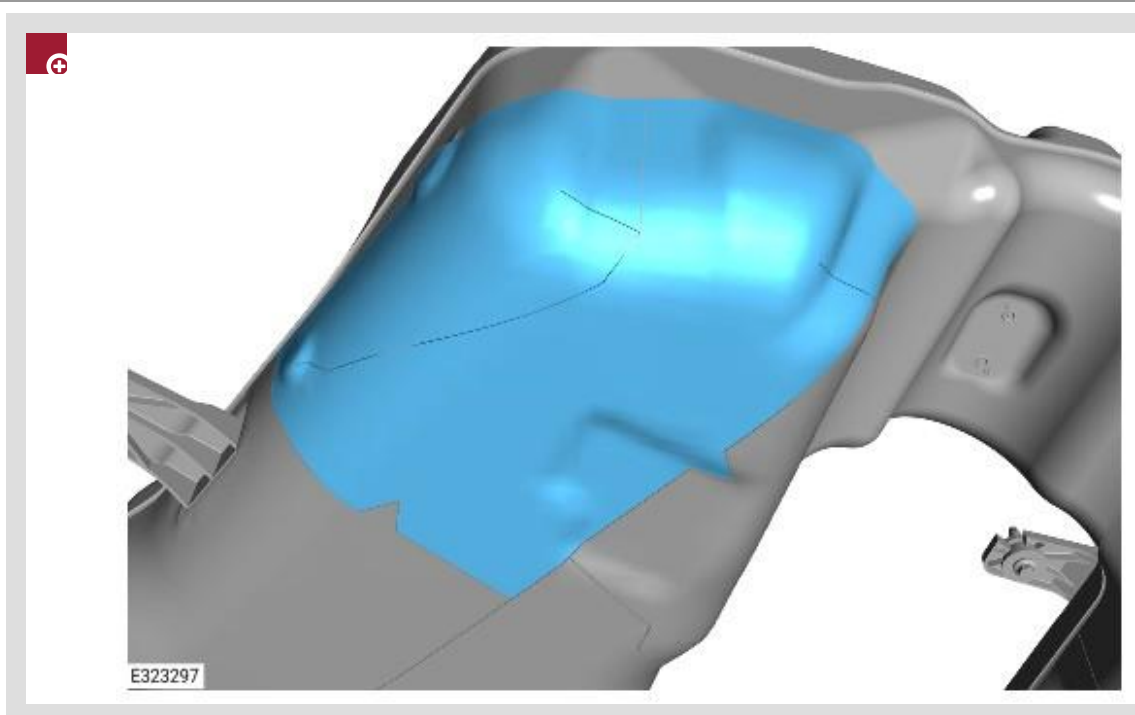

Apply adhesive insulation pad **L02** to the left side of the fuel tank in the location shown in the illustration.

22.

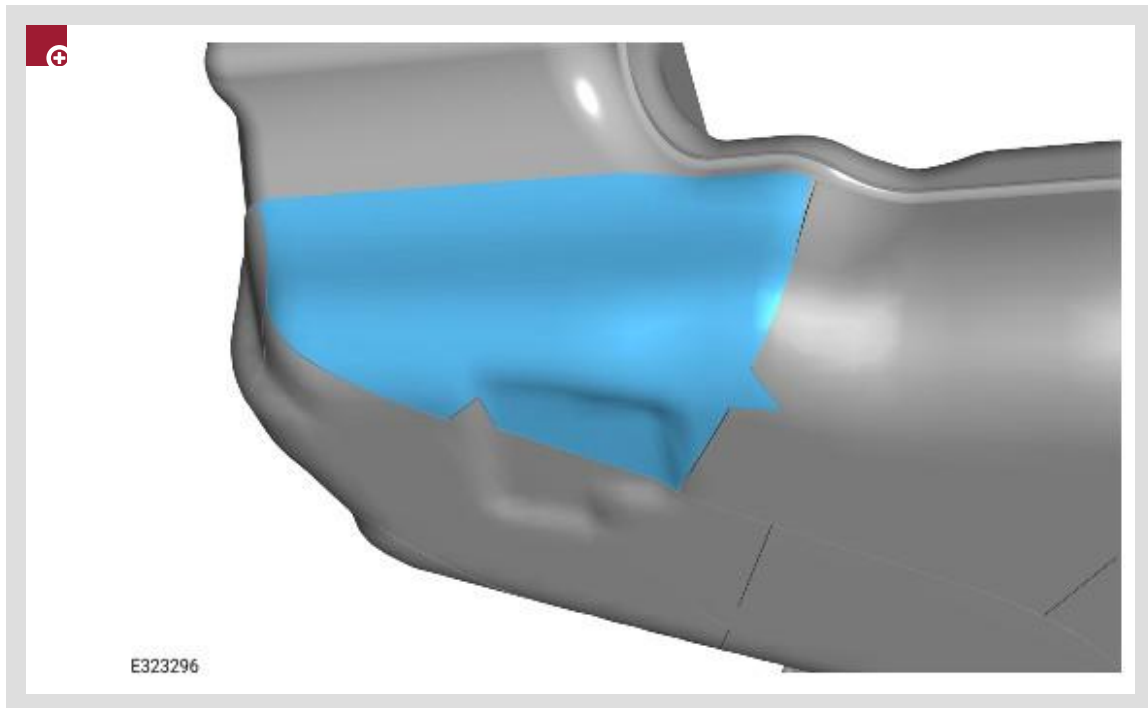

Apply adhesive insulation pad **L03** to the left side of the fuel tank in the location shown in the illustration.

23.

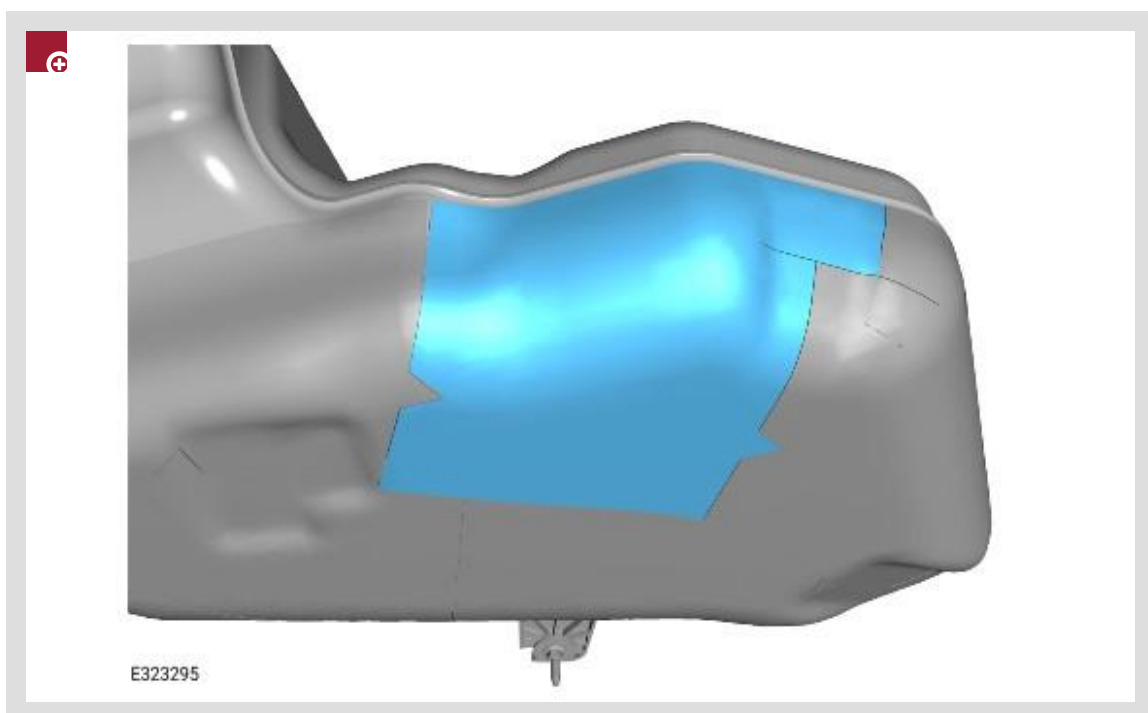

Apply adhesive insulation pad **L04** to the left side of the fuel tank in the location shown in the illustration.

24.

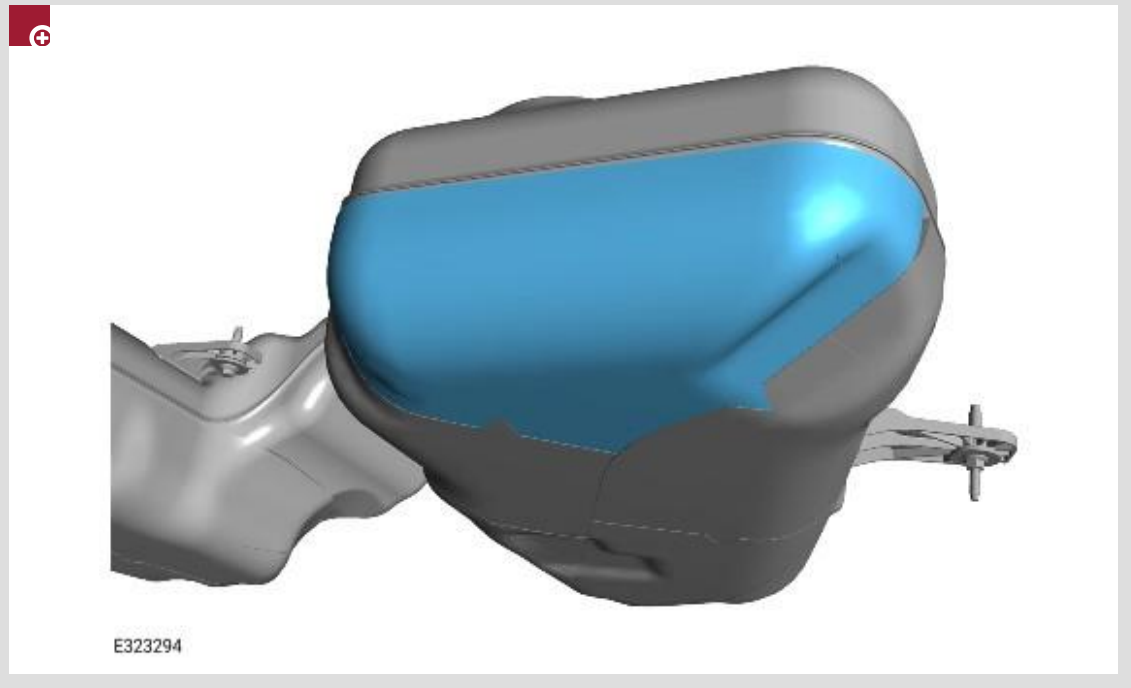

Apply adhesive insulation pad **L05** to the left side of the fuel tank in the location shown in the illustration.

25.

Apply reinforced aluminum tape to each join line between the adhesive insulation pads.

26.

Apply reinforced aluminum tape along the upper edge of the adhesive insulation pads, around the left side of the fuel tank.

27.

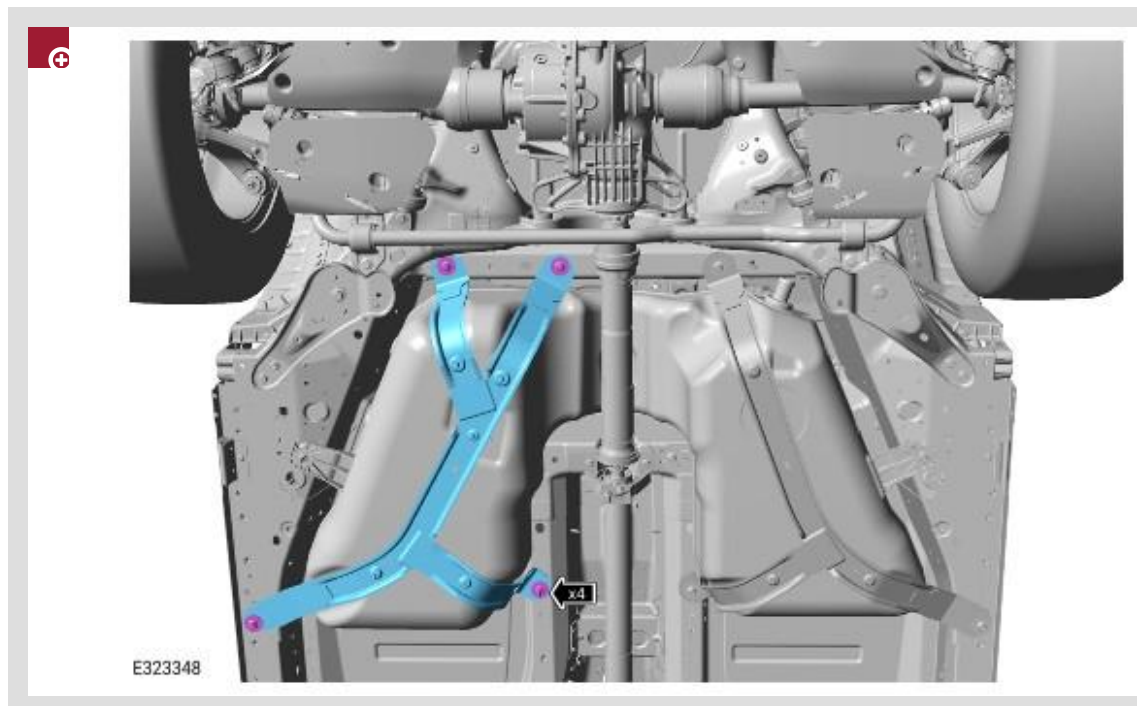

Install the left fuel tank support strap.

- Install the 4 bolts.
 - Torque: **45Nm**

28.

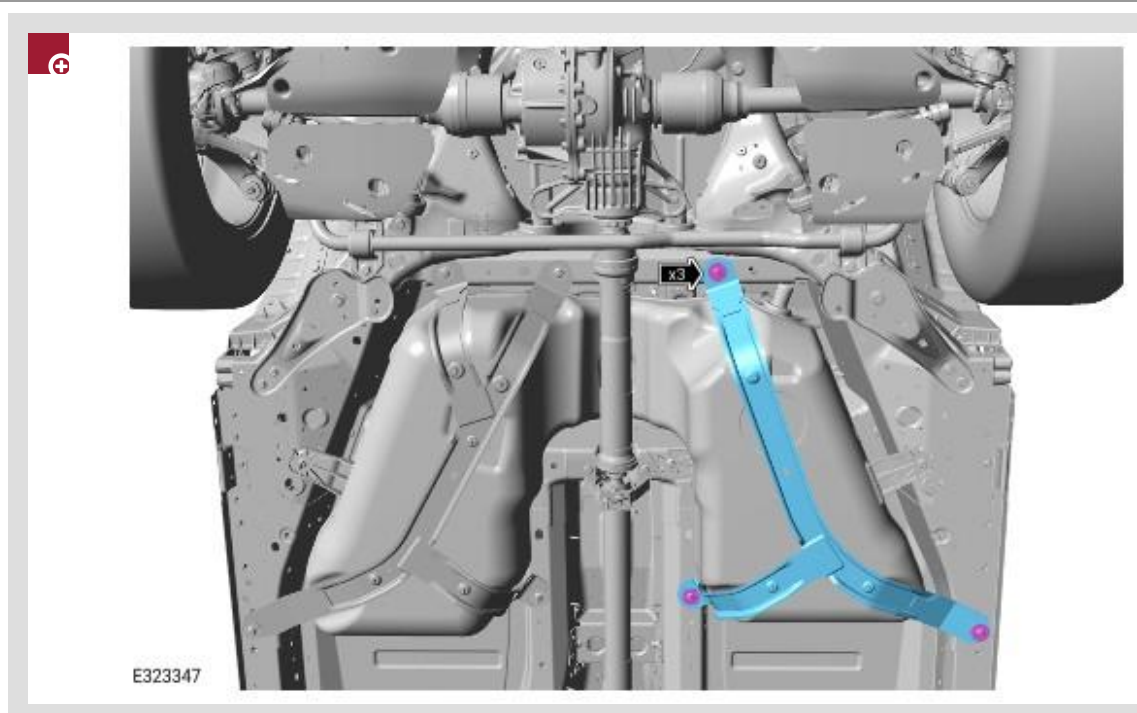

Remove the right fuel tank support strap.

- Remove the 3 bolts.

29.

The fuel tank must be clean and free from contamination before continuing to the next step.

30.

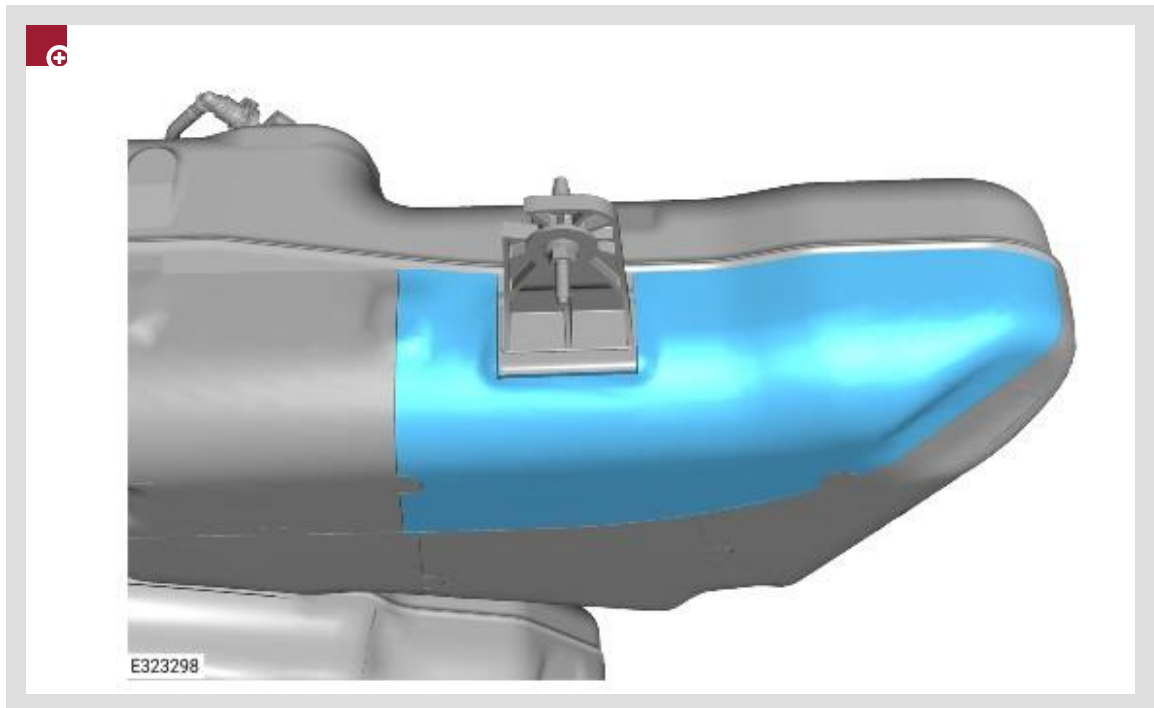

Apply adhesive insulation pad **R01** to the right side of the fuel tank in the locations shown in the illustration.

31.

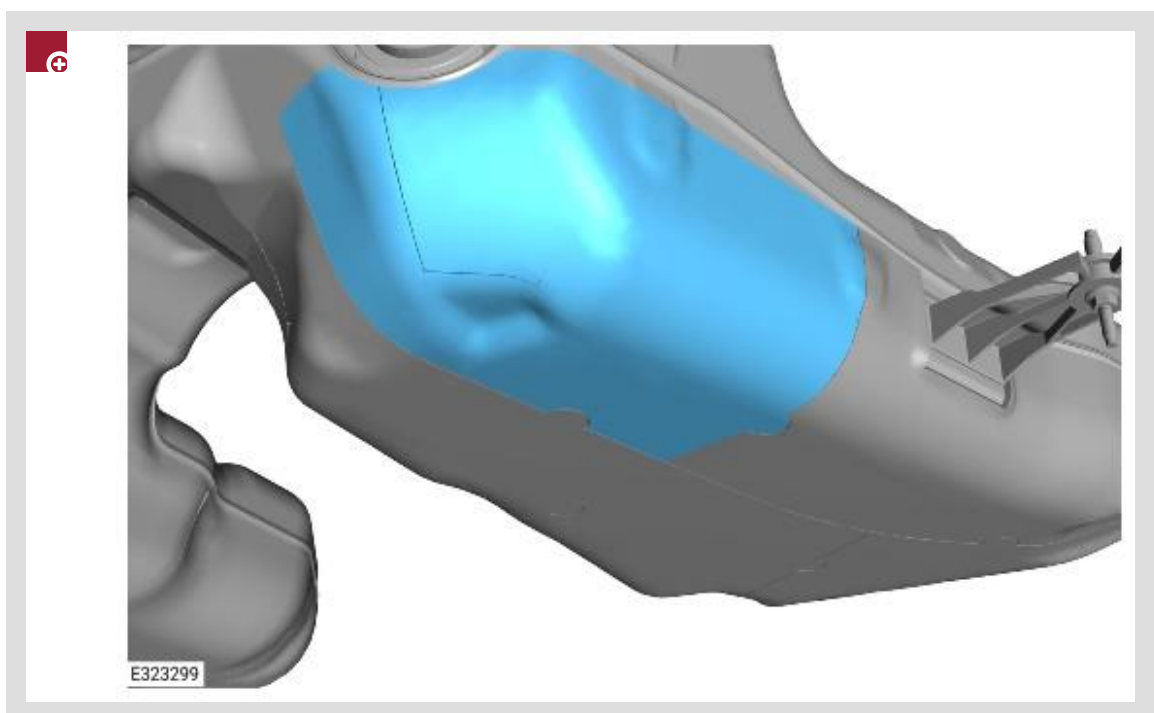

Apply adhesive insulation pad **R02** to the right side of the fuel tank in the locations shown in the illustration.

32.

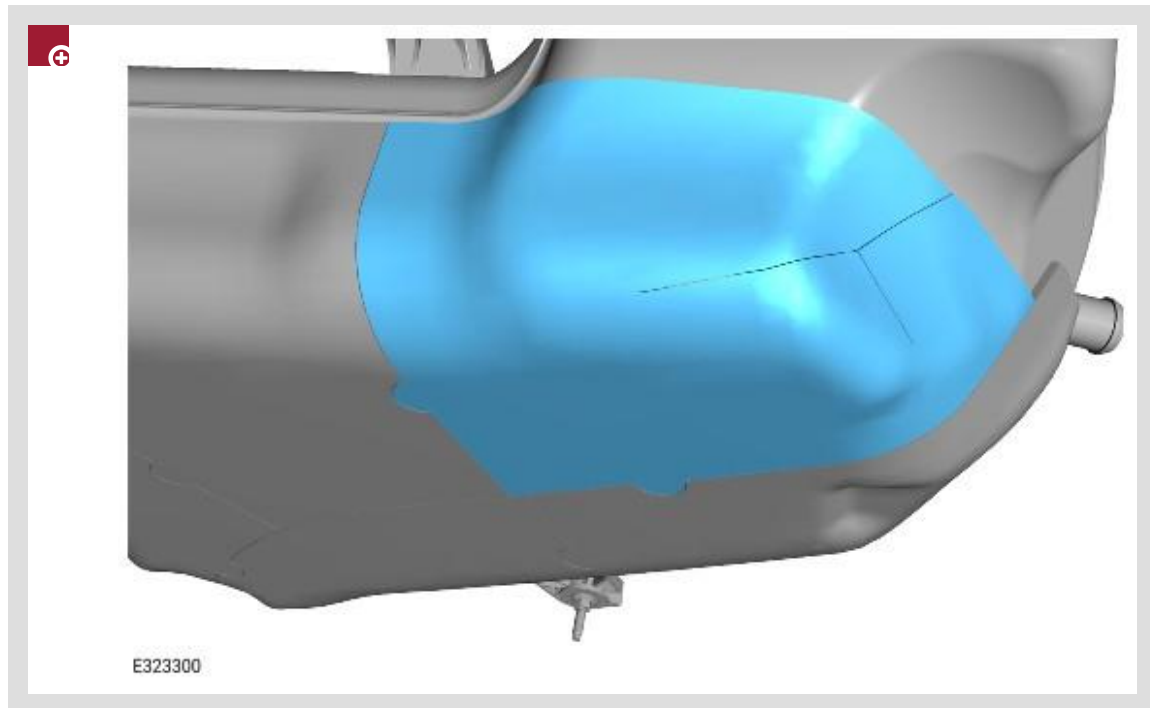

Apply adhesive insulation pad **R03** to the right side of the fuel tank in the locations shown in the illustration.

33.

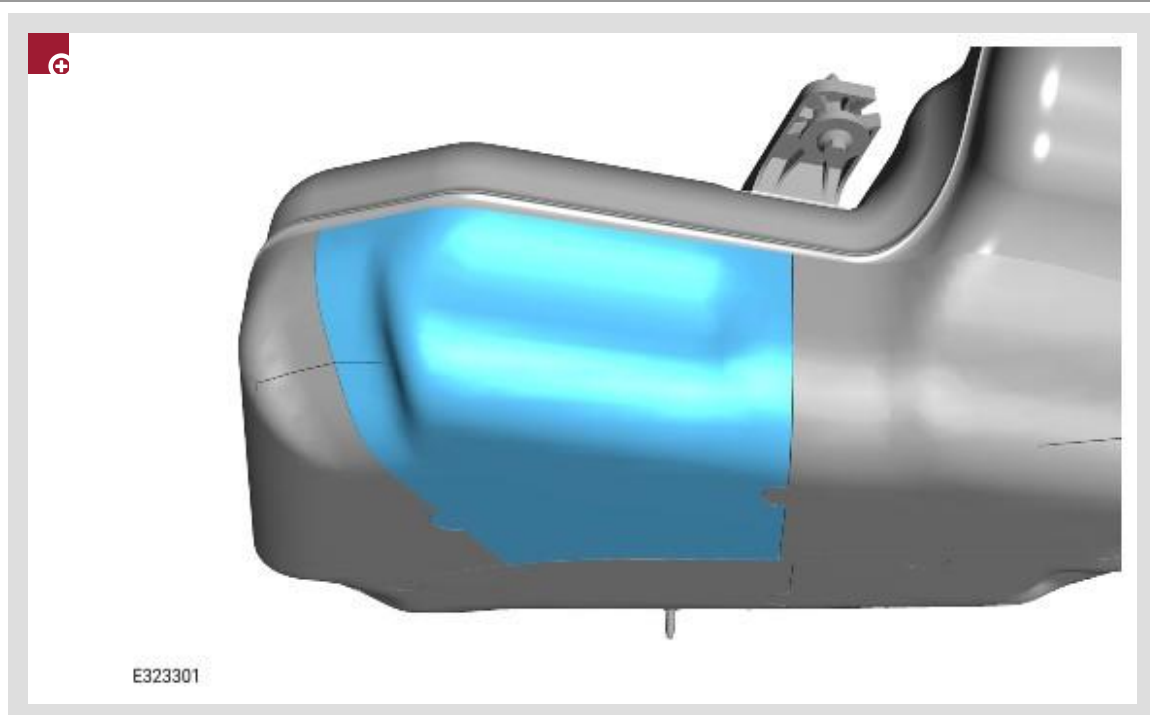

Apply adhesive insulation pad **R04** to the right side of the fuel tank in the locations shown in the illustration.

34.

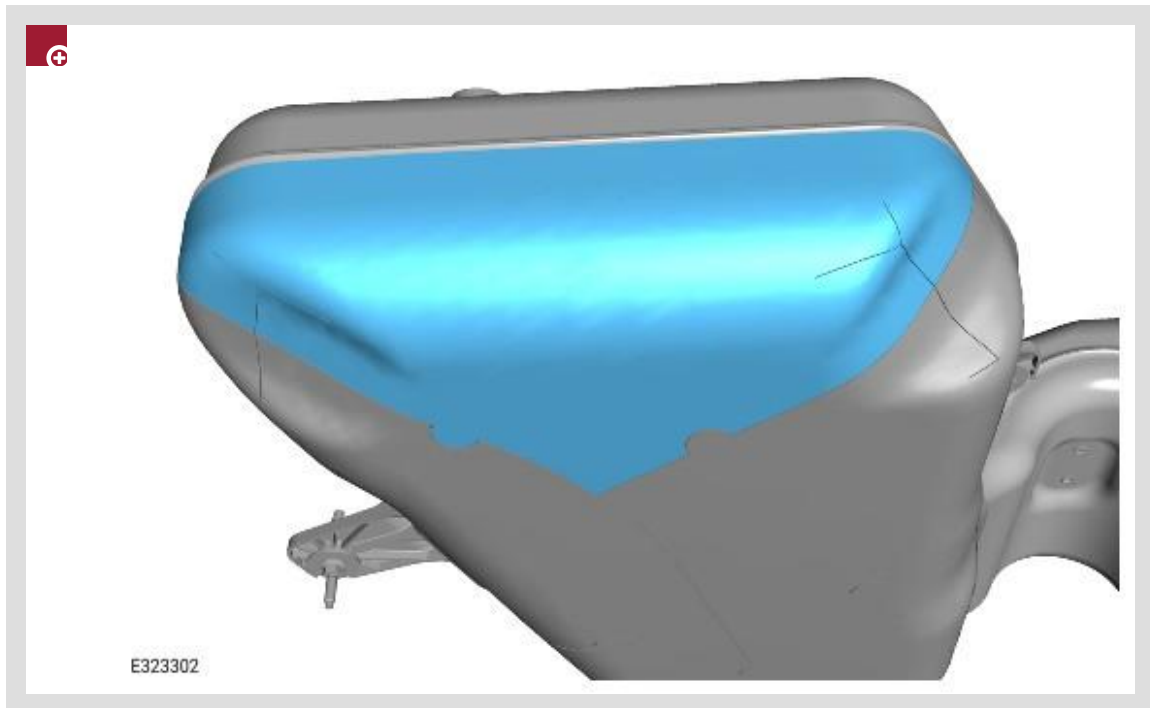

Apply adhesive insulation pad **R05** to the right side of the fuel tank in the locations shown in the illustration.

35.

Apply reinforced aluminum tape to each join line between the adhesive insulation pads.

36.

Apply reinforced aluminum tape along the upper edge of the adhesive insulation pads, around the right side of the fuel tank.

37.

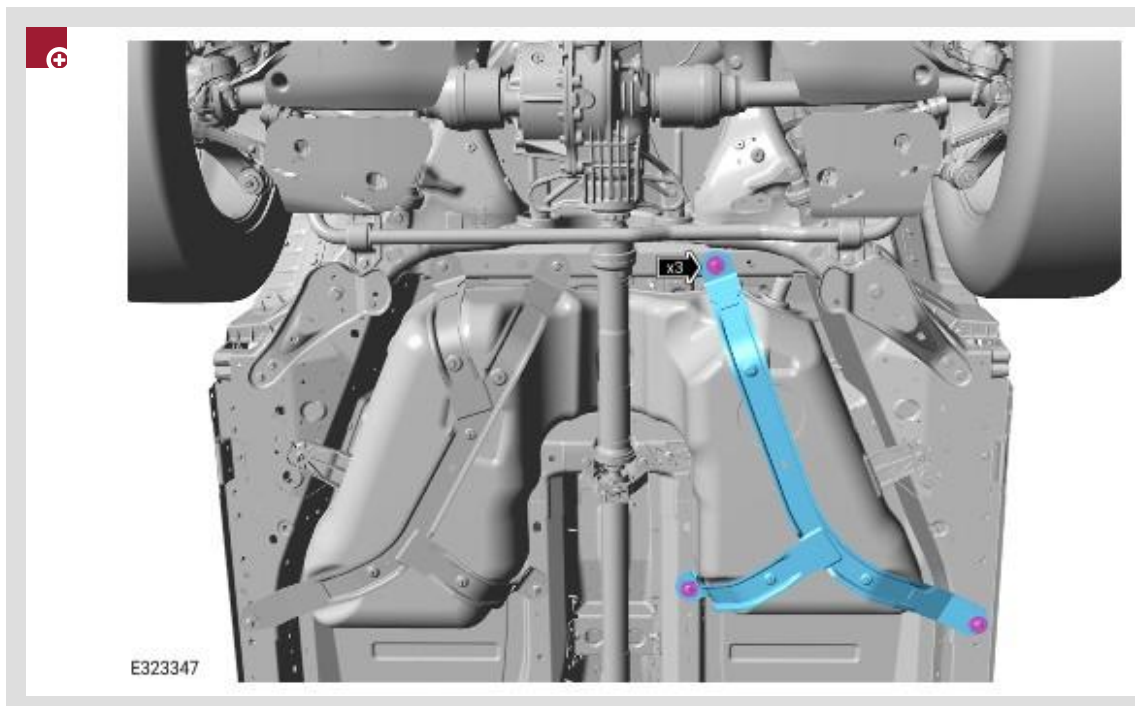

Install the right fuel tank support strap.

- Install the 3 bolts.
 - Torque: **45Nm**

38.

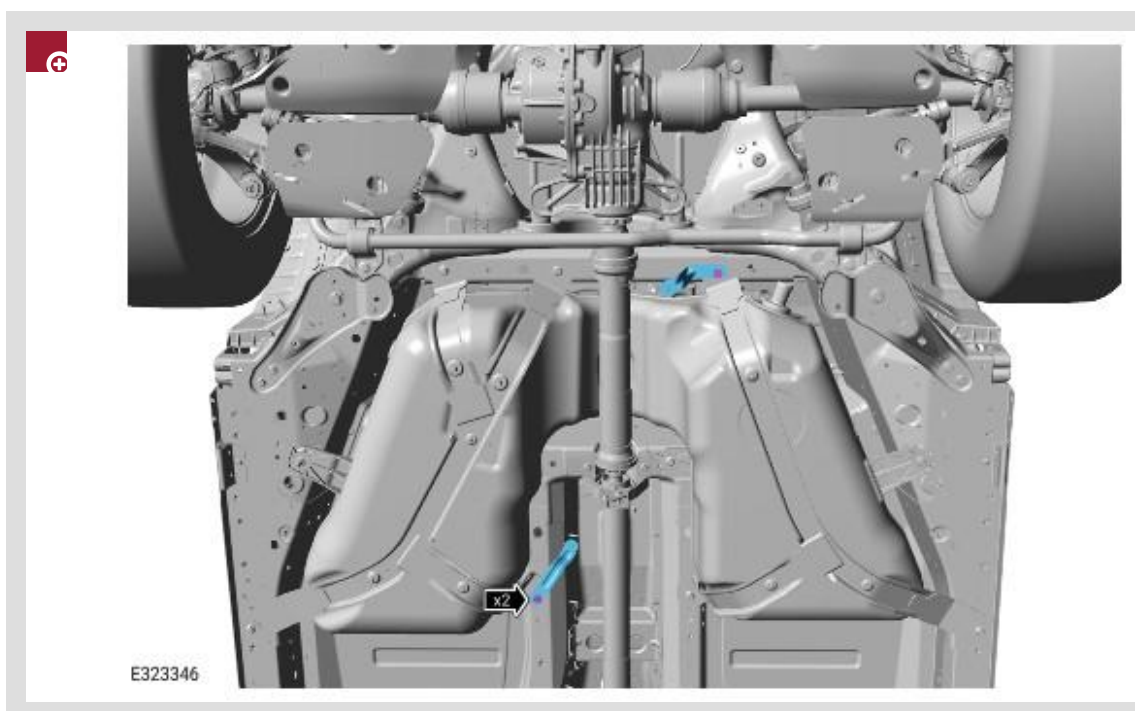

Install the 2 heatshield supporting brackets.

- Install the 2 nuts.
 - Torque: **10Nm**

All Vehicles

NOTE:

All vehicles must complete the remaining steps of this Service Instruction. The following steps provide the instructions to install the latest underbody service enhancement for the fuel vapor smell in passenger compartment symptom.

39.

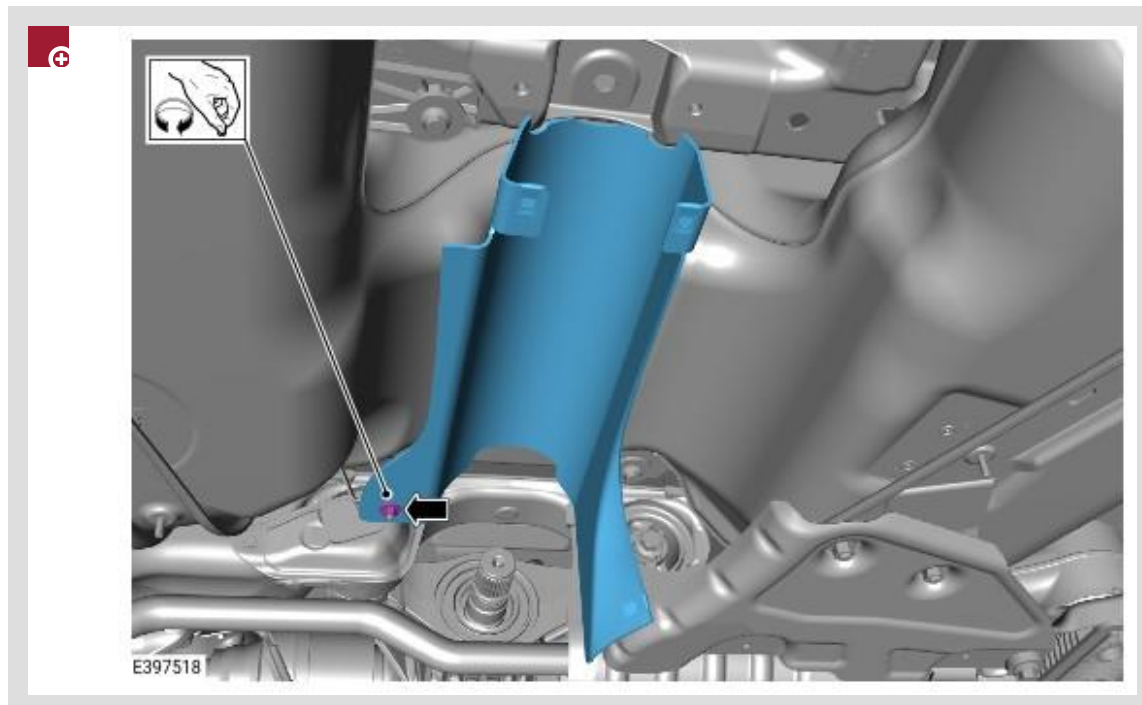

Position the rear driveshaft heatshield as shown in the illustration.

- Temporarily secure the heatshield by installing a nut removed previously, but do not tighten.

40.

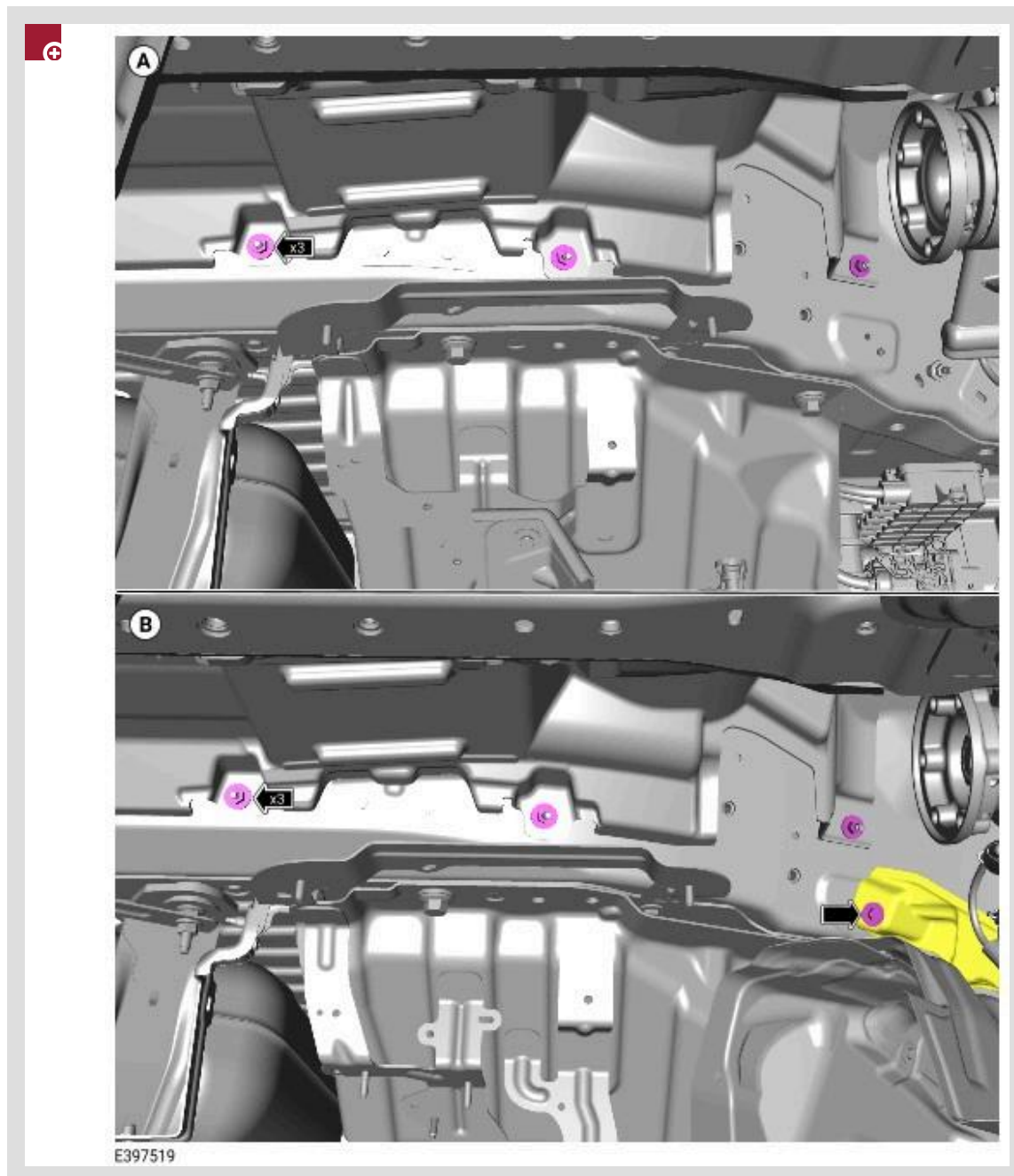

Follow the instruction below that is applicable to the specification of vehicle.

- **(A) INGENIUM I6 3.0L Petrol / V8 T/C 4.4L Petrol NC10 vehicles -**
Remove and retain the 3 nuts.
- **(B) V8 T/C 4.4L Petrol NC11 vehicles -** Remove and retain the 3 nuts and the bolt.

41.

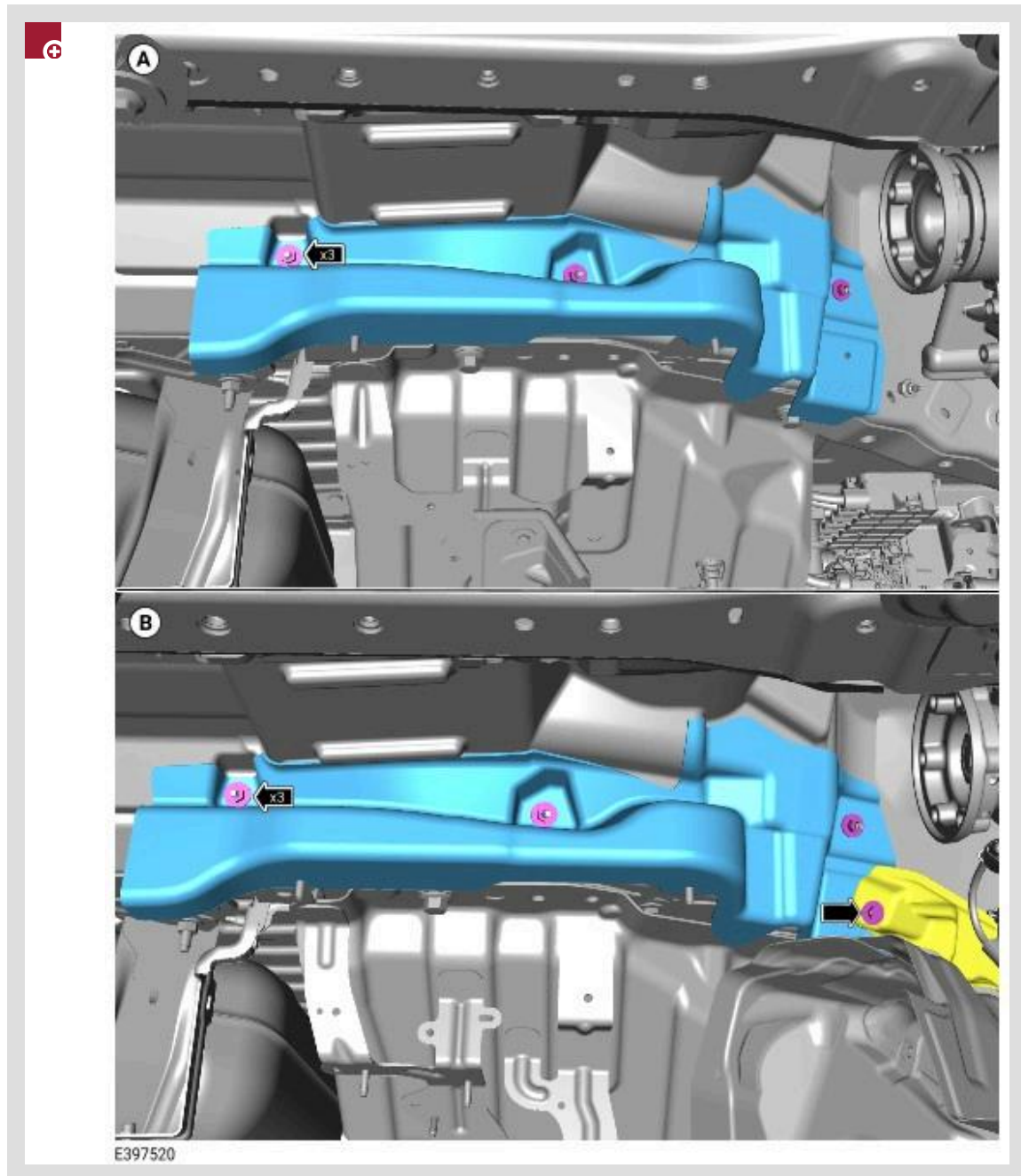

Follow the instruction below that is applicable to the specification of vehicle.

- **(A) INGENIUM I6 3.0L Petrol / V8 T/C 4.4L Petrol NC10 vehicles** - Install the left upper heatshield.
 - Install the 3 nuts previously removed.
 - Torque: **5Nm**
- **(B) V8 T/C 4.4L Petrol NC11 vehicles** - Install the left upper heatshield.
 - Install the 3 nuts previously removed.
 - Torque: **5Nm**
 - Install the bolt previously removed.
 - Torque: **5Nm**

42. Clean the rear driveshaft mating faces.
- Clean the transfer case output flange mating face.
 - Clean the rear differential mating face.

43. Install new rear differential pinion O-ring and pinion clip.

44.  **NOTE:**

This step will require an additional technician.

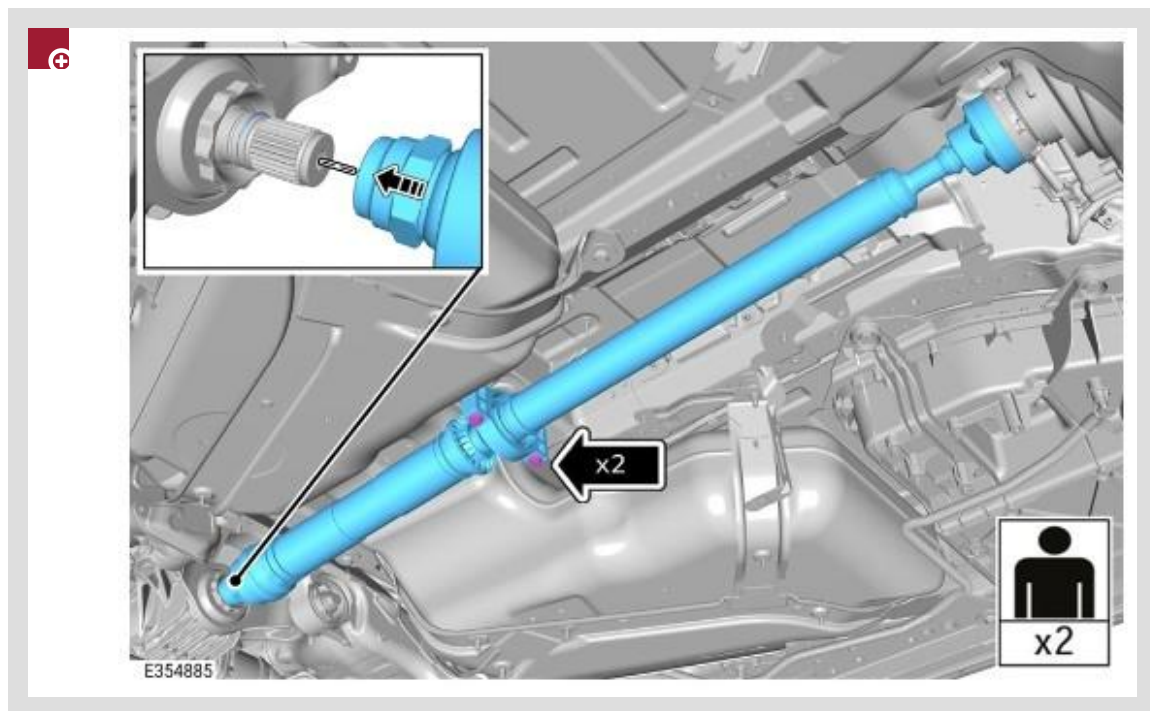

Install the rear driveshaft to the alignment marks made in the removal process.

- The rear driveshaft must be inserted onto the rear differential pinion until the clip is engaged.
- Install and tighten the 2 bolts.
 - Torque: **48Nm**

45.

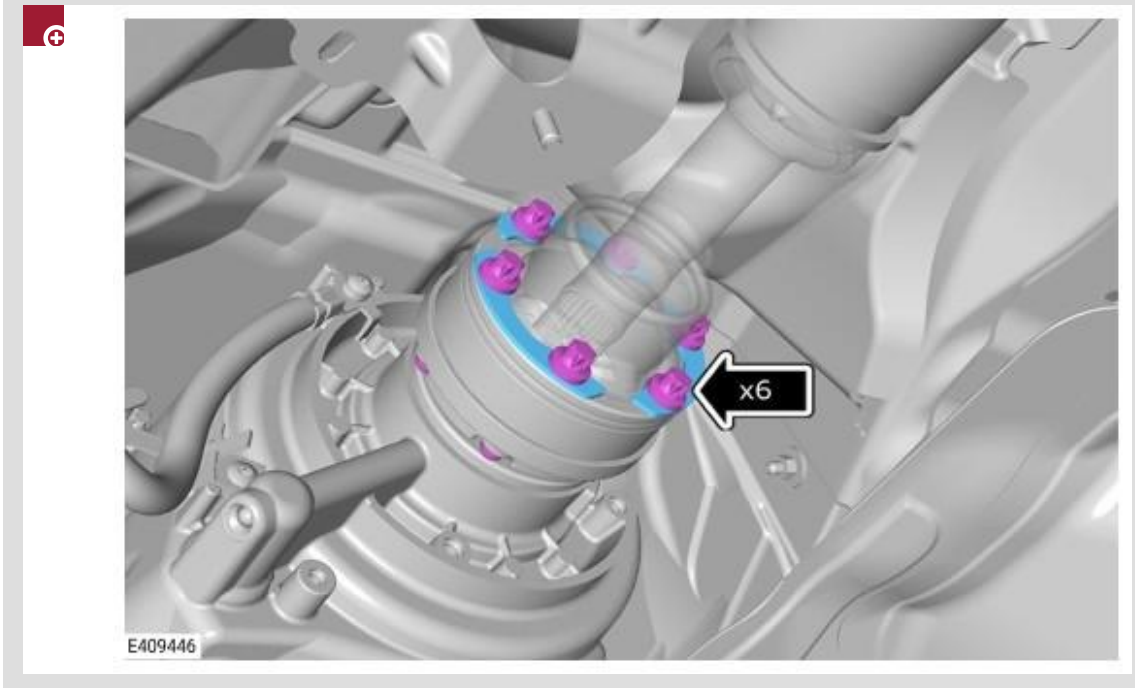

Install 3 new rear driveshaft link washers and 6 new bolts.

- Torque: **73Nm**

46.

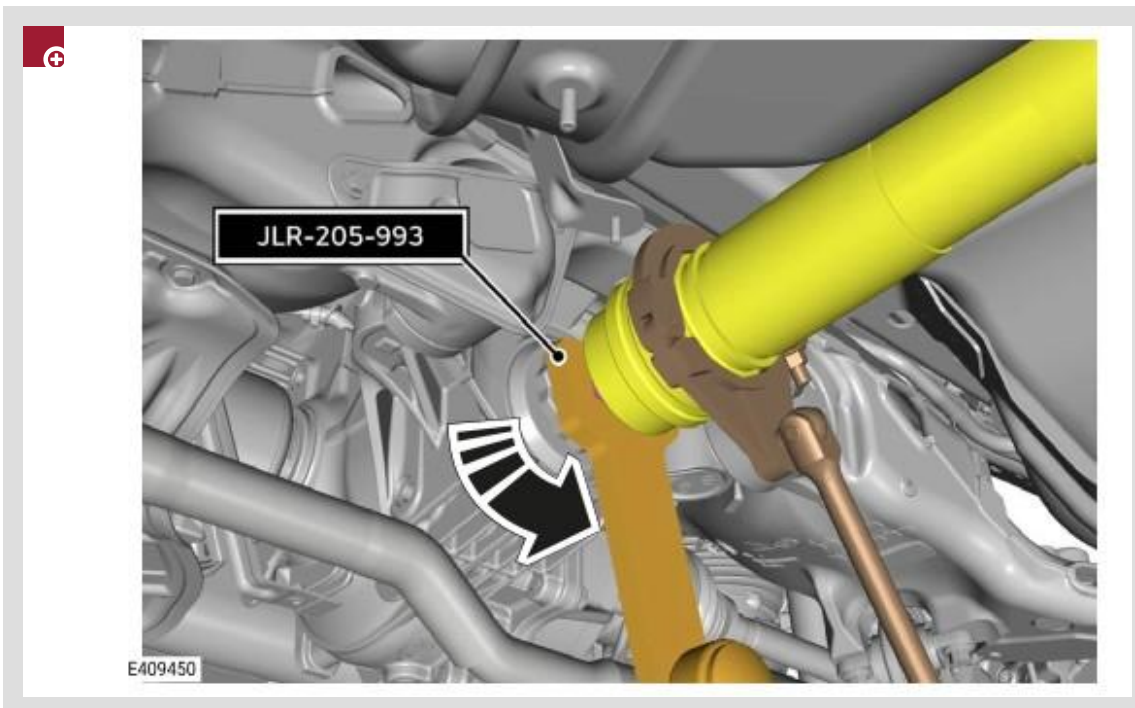

Use the special tools to install the rear driveshaft nut to the rear differential.

- Torque: **150Nm**

47.

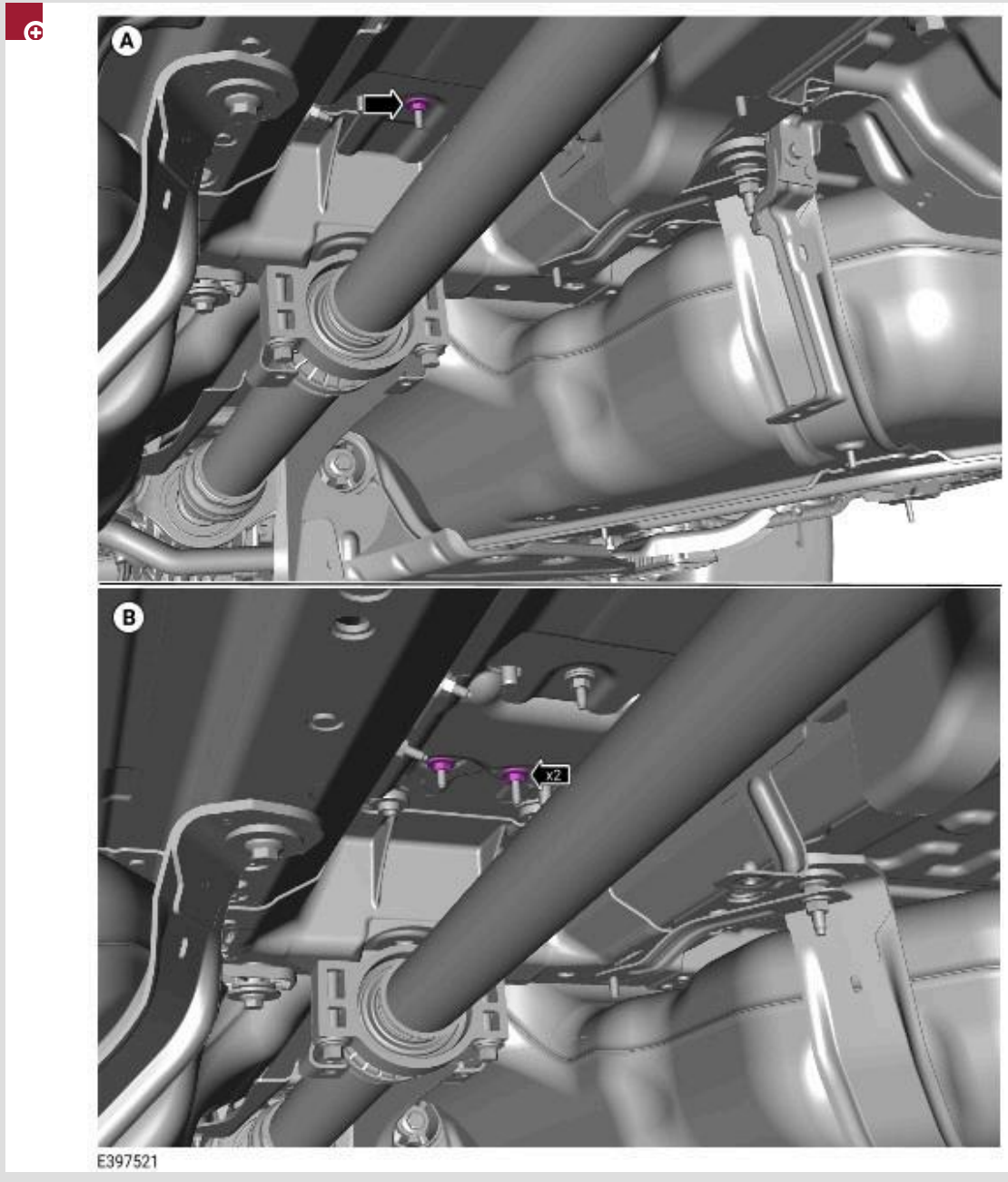

Follow the instruction below that is applicable to the specification of vehicle.

- **(A) SWB vehicles** - Remove and retain the nut.
- **(B) LWB vehicles** - Remove and retain the 2 nuts.

48.

 **NOTE:**

The heatshields must be aligned with the locating fixtures and the studs.

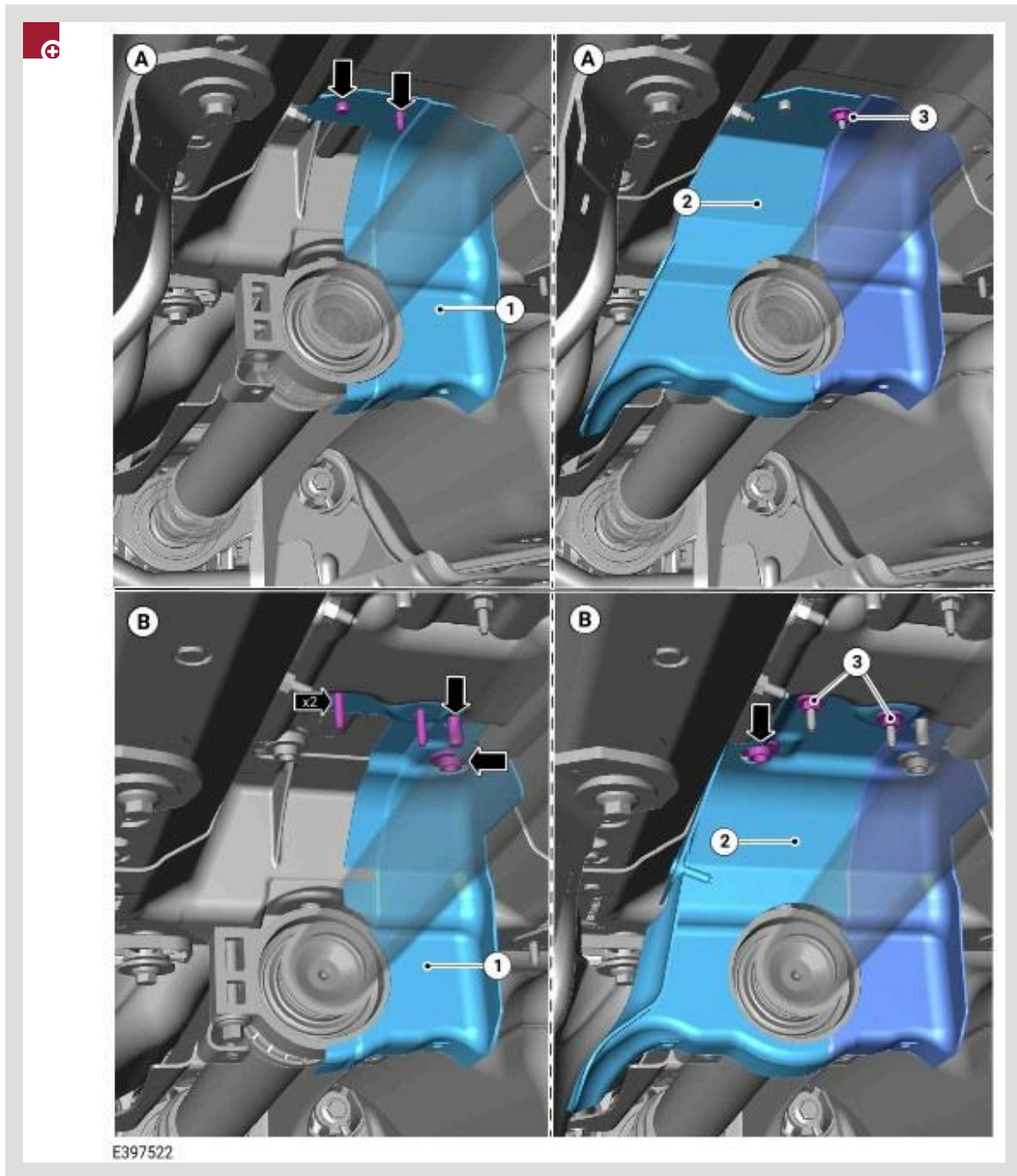

Follow the instruction below that is applicable to the specification of vehicle.

- **(A) SWB vehicles** - Install the left and right center bearing heatshield.
 1. Position the first heatshield as shown in the illustration.
 2. Install the second heatshield as shown in the illustration.
 3. Install and tighten the nut previously removed.

Torque: **5Nm**

- **(B) LWB vehicles** - Install the left and right center bearing heatshield.
 1. Position the first heatshield as shown in the illustration.

2. Install the second heatshield as shown in the illustration.

3. Install and tighten the 2 nuts previously removed.

Torque: **5Nm**

49.

 **NOTE:**

The rear driveshaft is shown removed for clarity.

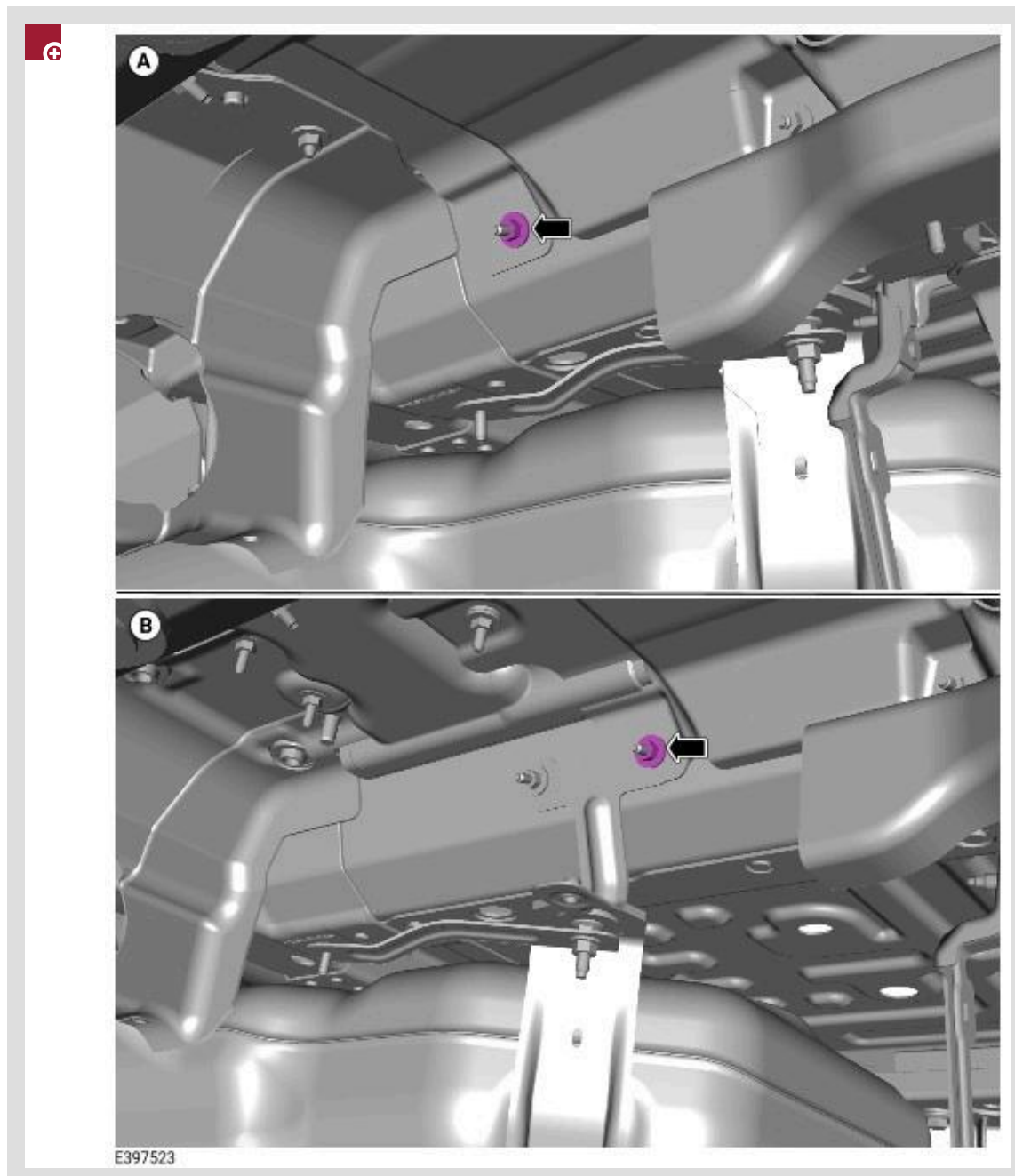

Follow the instruction below that is applicable to the specification of vehicle.

- **(A) SWB vehicles** - Remove and retain the nut.
- **(B) LWB vehicles** - Remove and retain the nut.

50.

 **NOTE:**

The rear driveshaft is shown removed for clarity.

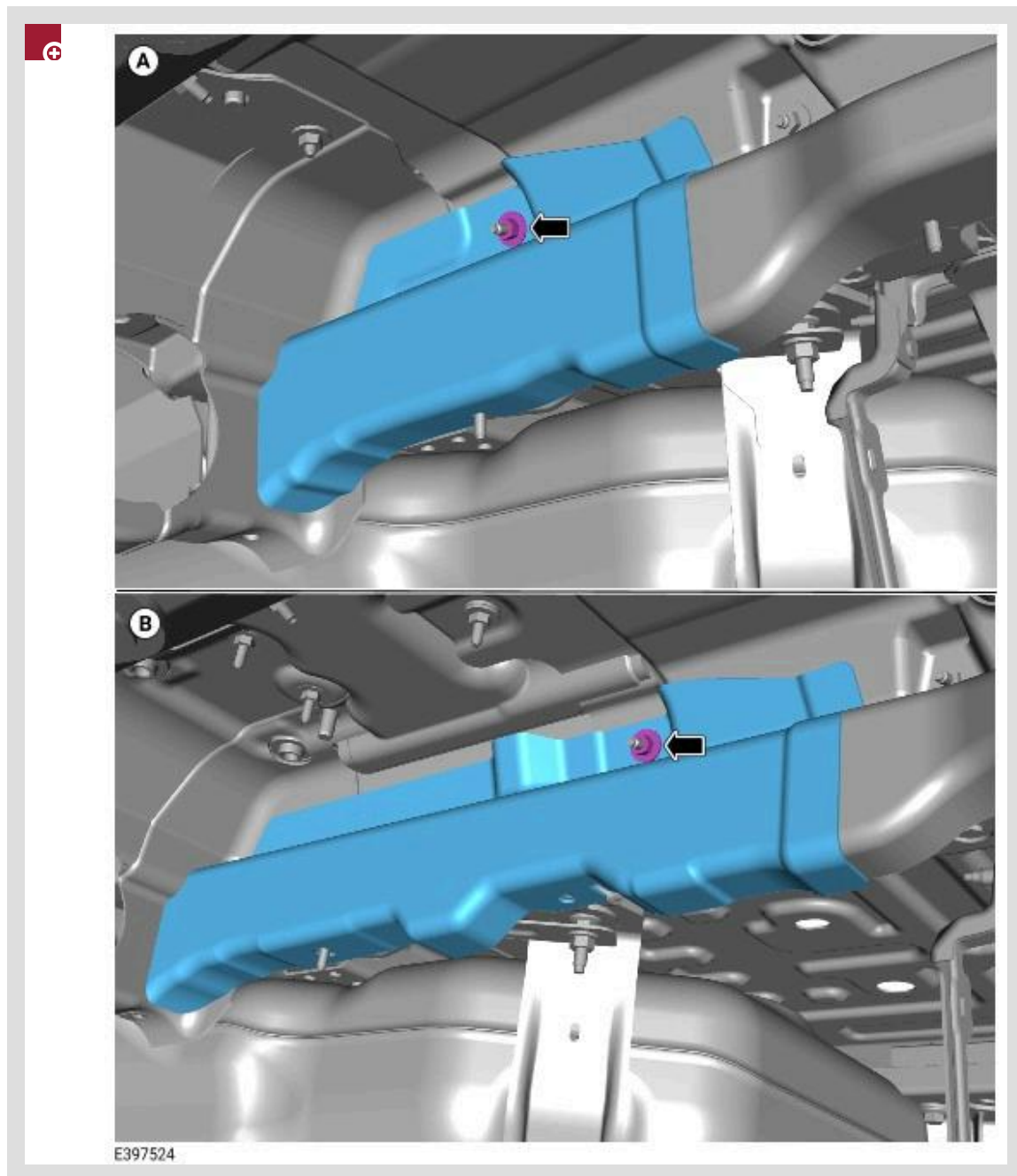

Follow the instruction below that is applicable to the specification of vehicle.

- **(A) SWB vehicles** - Install the rear left upper heatshield.
 - Install the nut previously removed.
 - Torque: **5Nm**
- **(B) LWB vehicles** - Install the rear left upper heatshield.
 - Install the nut previously removed.
 - Torque: **5Nm**

51.

 **NOTES:**

- This step is required for all SWB vehicles.
- The rear driveshaft is shown removed for clarity.

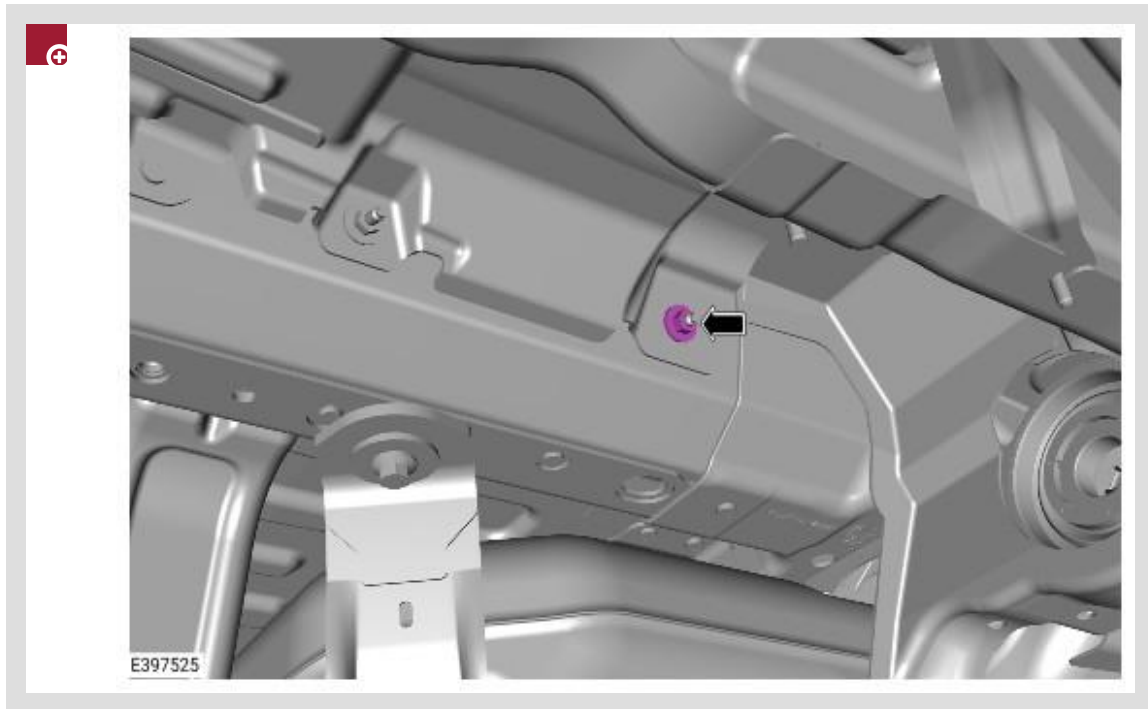

Remove and retain the nut.

52.

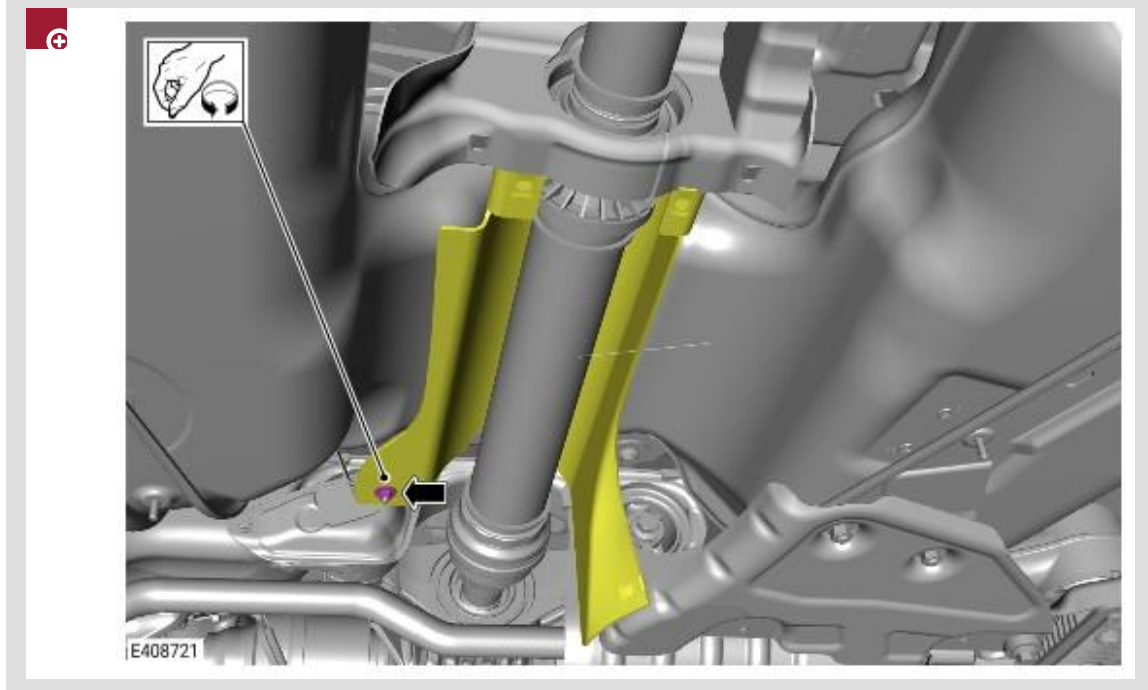

Remove and retain the nut.

53.

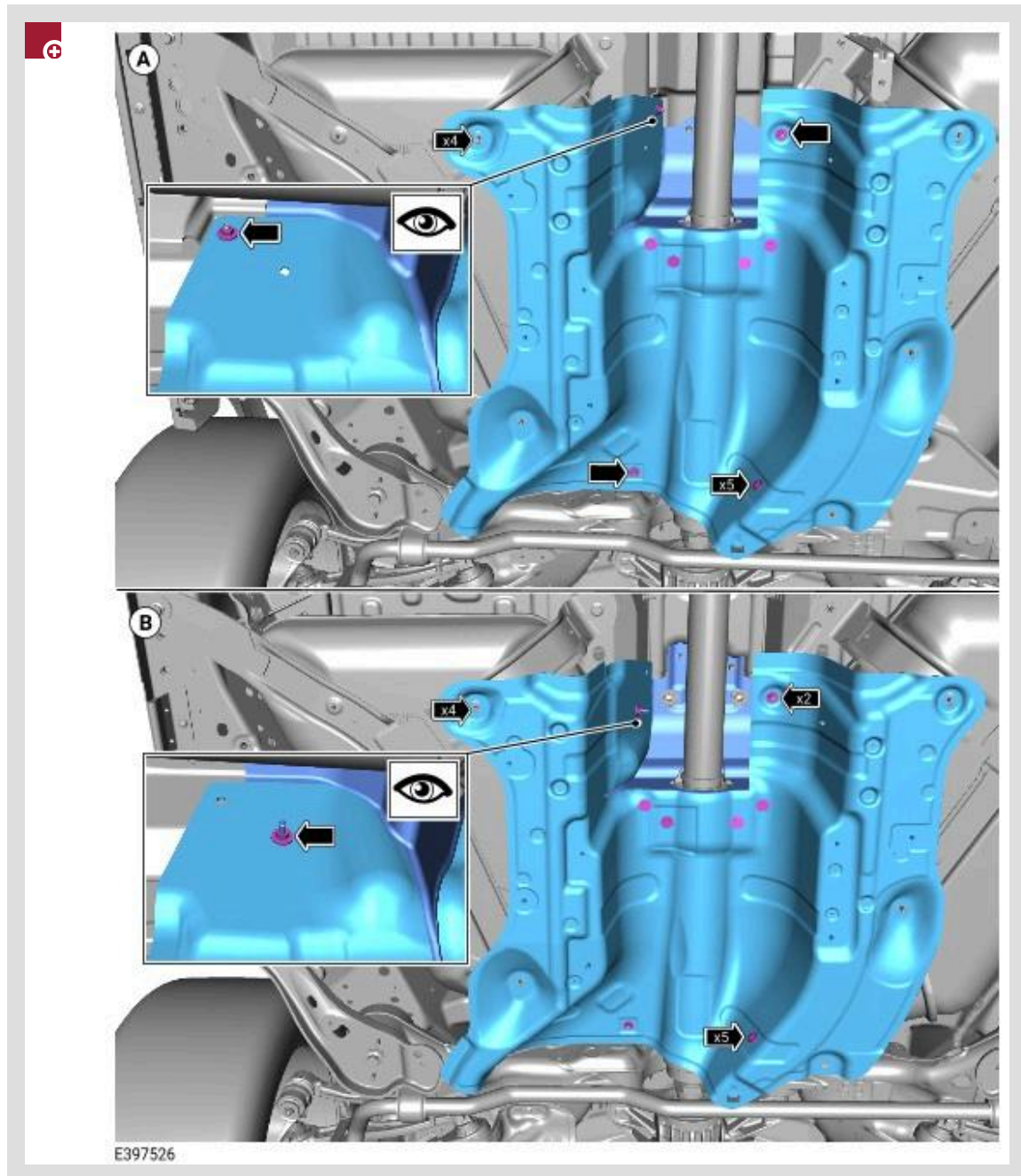

Follow the instruction below that is applicable to the specification of vehicle.

- **(A) SWB vehicles** - Install the new fuel tank heatshield.
 - Secure the new fuel tank heatshield onto the 4 studs.
 - Torque: **5Nm**
 - Install 5 new bolts (AYP500110).
 - Torque: **5Nm**
 - Install the 3 nuts previously removed.
 - Torque: **5Nm**
- **(B) LWB vehicles** - Install the new fuel tank heatshield.
 - Secure the new fuel tank heatshield onto the 4 studs.
 - Torque: **5Nm**

- Install 5 new bolts (AYP500110).
 - Torque: **5Nm**
- Install the 2 nuts previously removed.
 - Torque: **5Nm**
- Install 1 new nut (RYH500310).
 - Torque: **5Nm**

54.



Follow the instruction below that is applicable to the specification of vehicle.

- **(A) SWB vehicles** - Remove and retain the 2 nut.
- **(B) LWB vehicles** - Remove and retain the 4 nuts.

55.

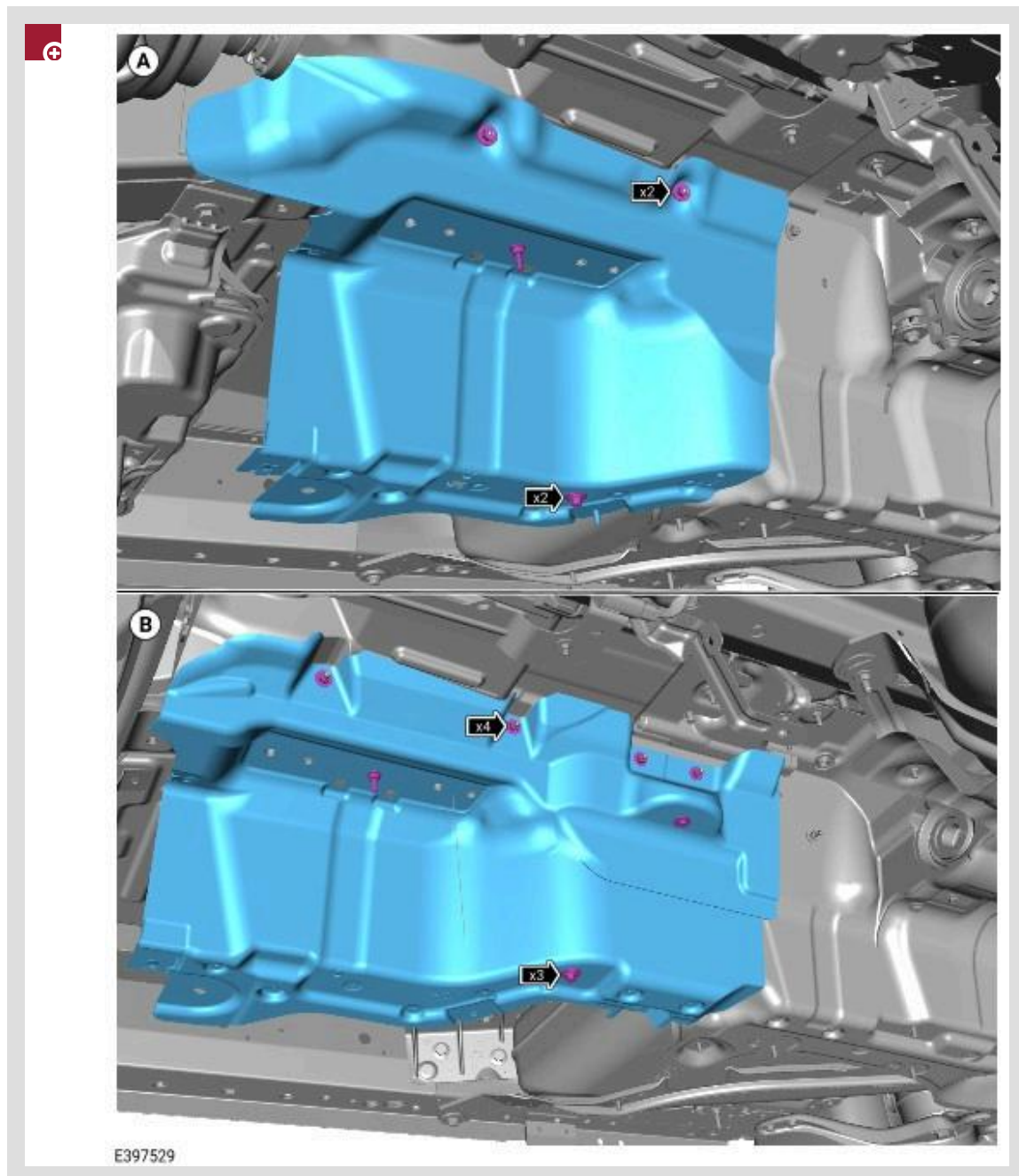

Follow the instruction below that is applicable to the specification of vehicle.

- **(A) SWB vehicles** - Install the new right heatshield.
 - Install the 2 nuts previously removed.
 - Torque: **5Nm**
 - Install the 2 bolts previously removed.
 - Torque: **5Nm**
- **(B) LWB vehicles** - Install the new right heatshield.
 - Install the 4 nuts previously removed.
 - Torque: **5Nm**
 - Install the 3 bolts previously removed.
 - Torque: **5Nm**

56.

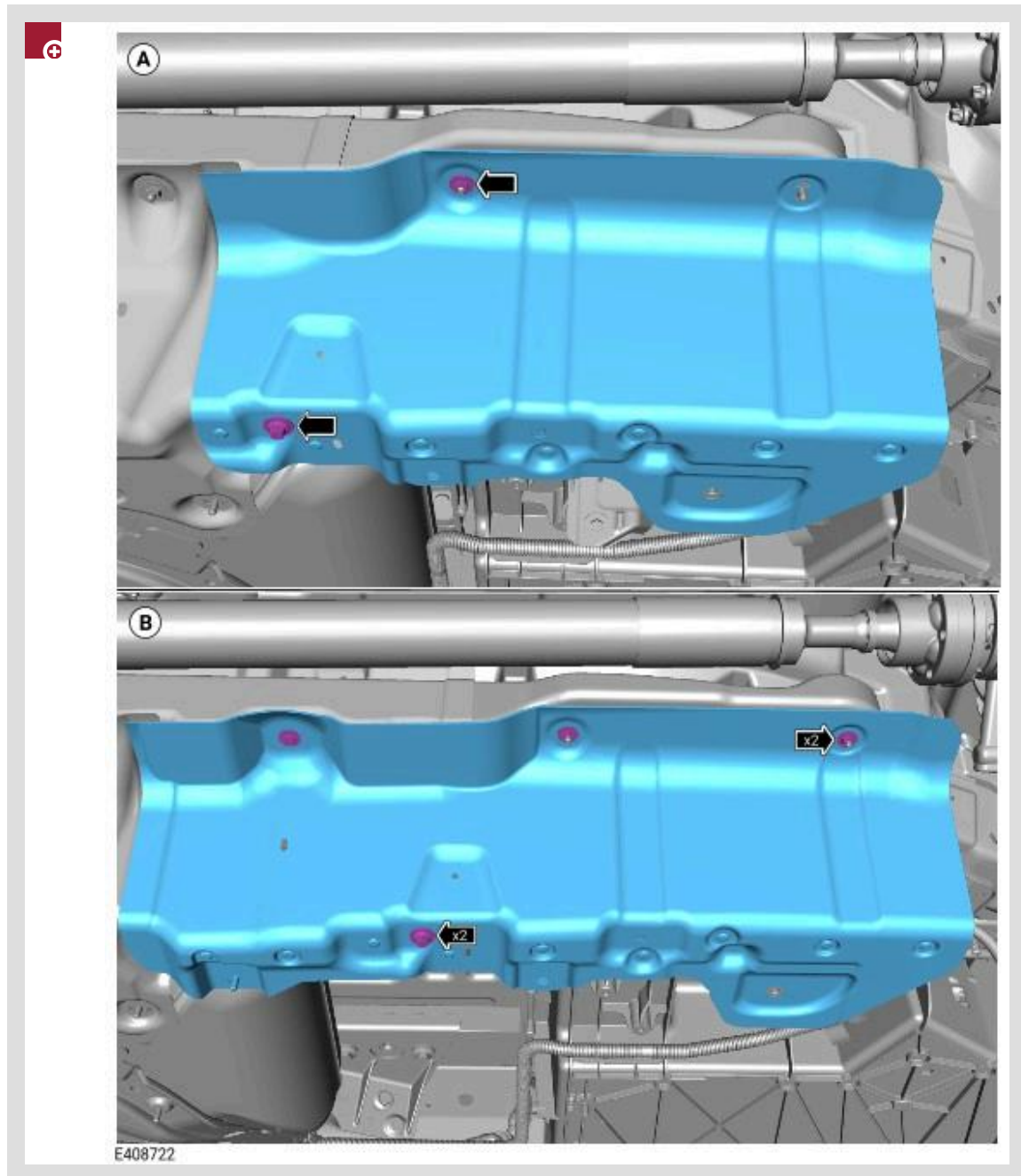

Follow the instruction below that is applicable to the specification of vehicle.

- **(A) SWB INGENIUM I6 3.0L Petrol vehicles to the end of 2024 model year** - Install the new left heatshield.
 - Install the nut previously removed.
 - Torque: **5Nm**
 - Install the bolt previously removed.
 - Torque: **5Nm**
- **(B) LWB INGENIUM I6 3.0L Petrol vehicles to the end of 2024 model year** - Install the new left heatshield.
 - Install the 2 nuts previously removed.
 - Torque: **5Nm**

- Install the 2 bolts previously removed.
 - Torque: **5Nm**

57.

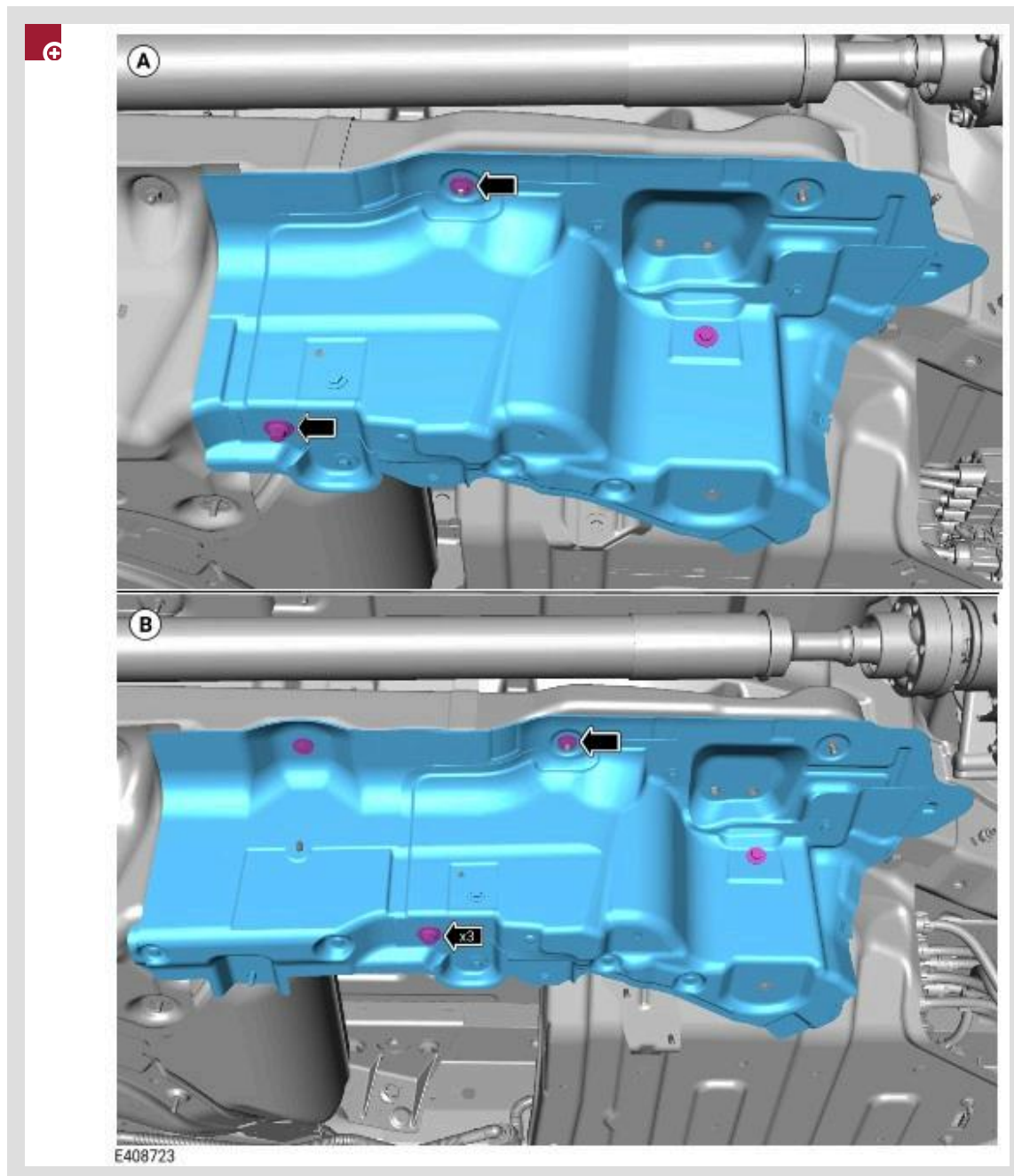

Follow the instruction below that is applicable to the specification of vehicle.

- **(A) SWB INGENIUM I6 3.0L Petrol vehicles from 2025 model year -**
Install the new left heatshield.
 - Install the nut previously removed.
 - Torque: **5Nm**
 - Install the bolt previously removed.
 - Torque: **5Nm**
- **(B) LWB INGENIUM I6 3.0L Petrol vehicles from 2025 model year -**
Install the new left heatshield.
 - Install the nut previously removed.
 - Torque: **5Nm**

- Install the 3 bolts previously removed.
 - Torque: **5Nm**

58.

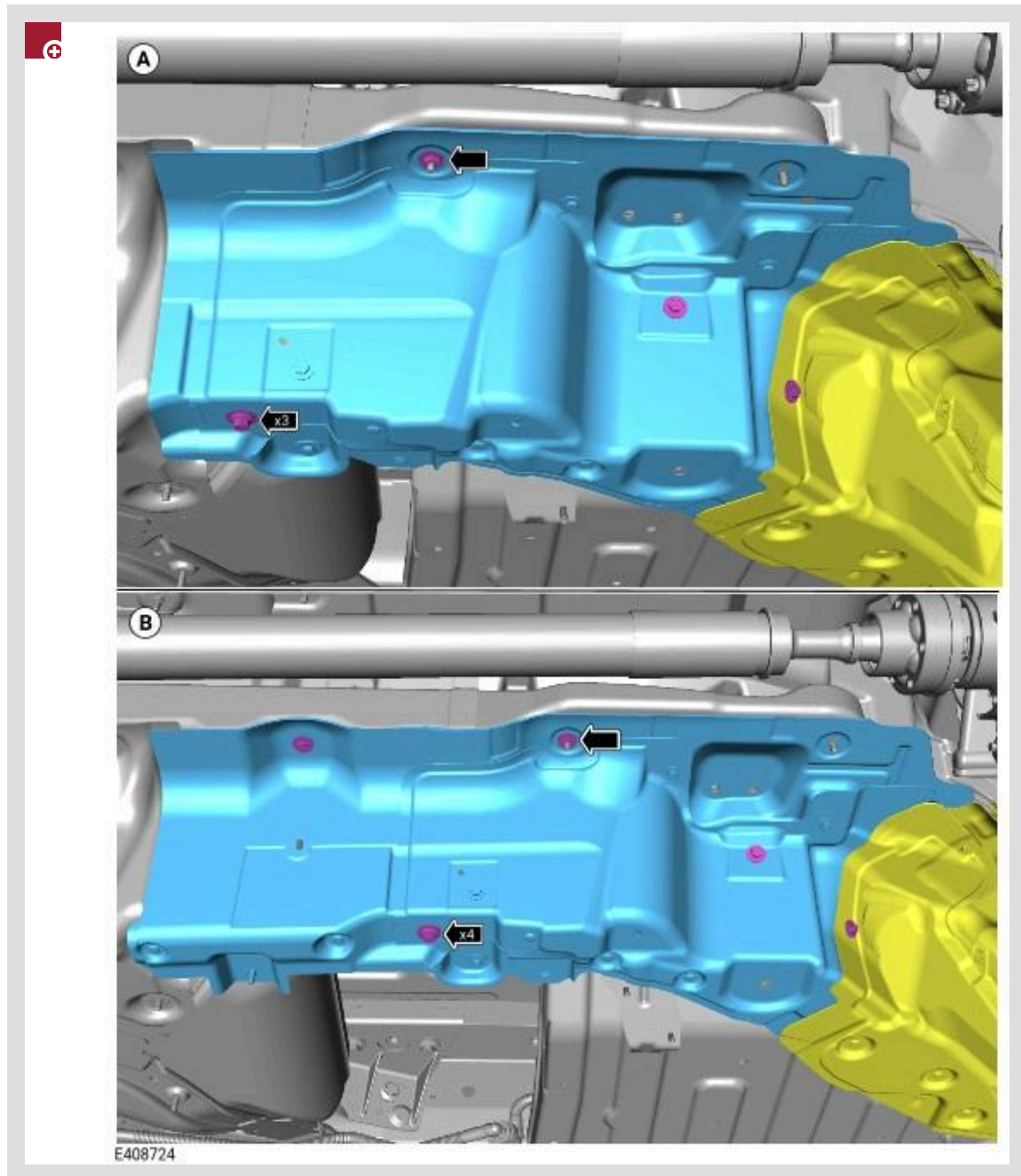

Follow the instruction below that is applicable to the specification of vehicle.

- **(A) SWB V8 T/C 4.4L Petrol NC11 vehicles** - Install the new left heatshield.
 - Install the nut previously removed.
 - Torque: **5Nm**
 - Install the 3 bolts previously removed.
 - Torque: **5Nm**
- **(B) LWB V8 T/C 4.4L Petrol NC11 vehicles** - Install the new left heatshield.
 - Install the nut previously removed.
 - Torque: **5Nm**

- Install the 4 bolts previously removed.
 - Torque: **5Nm**

59.

NOTE:

This step is required for ALL V8 T/C 4.4L Petrol NC10 vehicles.

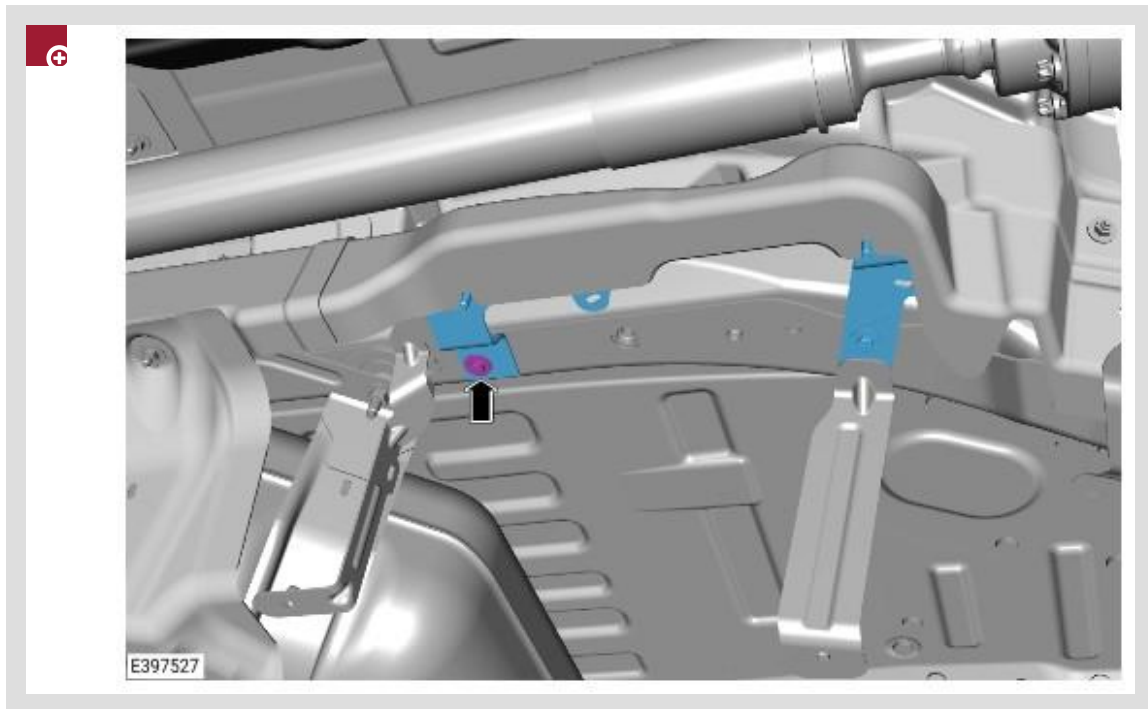

Remove and retain the bolt.

60.

NOTE:

This step is required for ALL V8 T/C 4.4L Petrol NC10 vehicles.

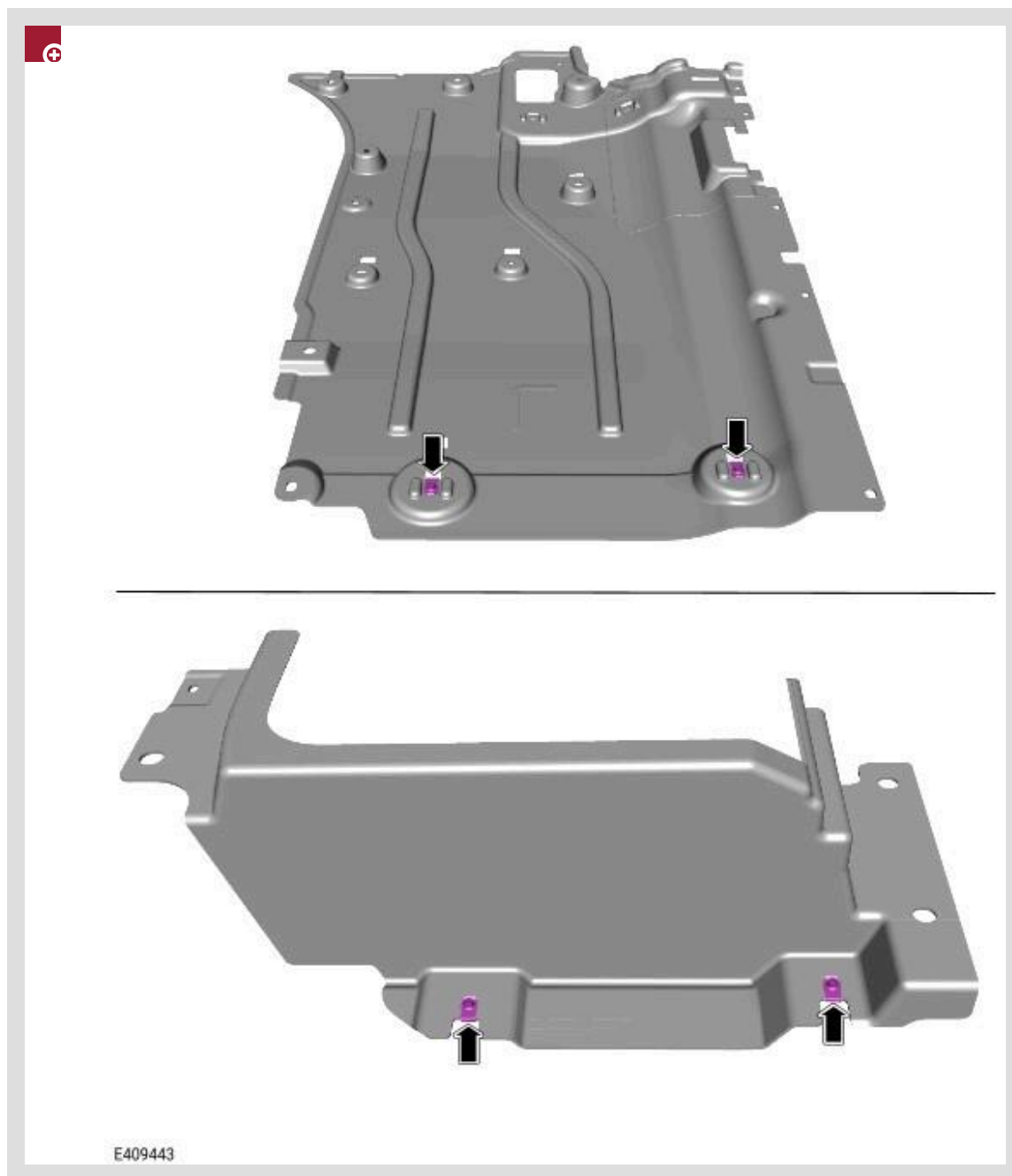

Remove the 2 U nut clips, shown highlighted in the illustration, from the left aero undershield and install onto the left heatshield.

61.

NOTE:

This step is required for ALL V8 T/C 4.4L Petrol NC10 vehicles.

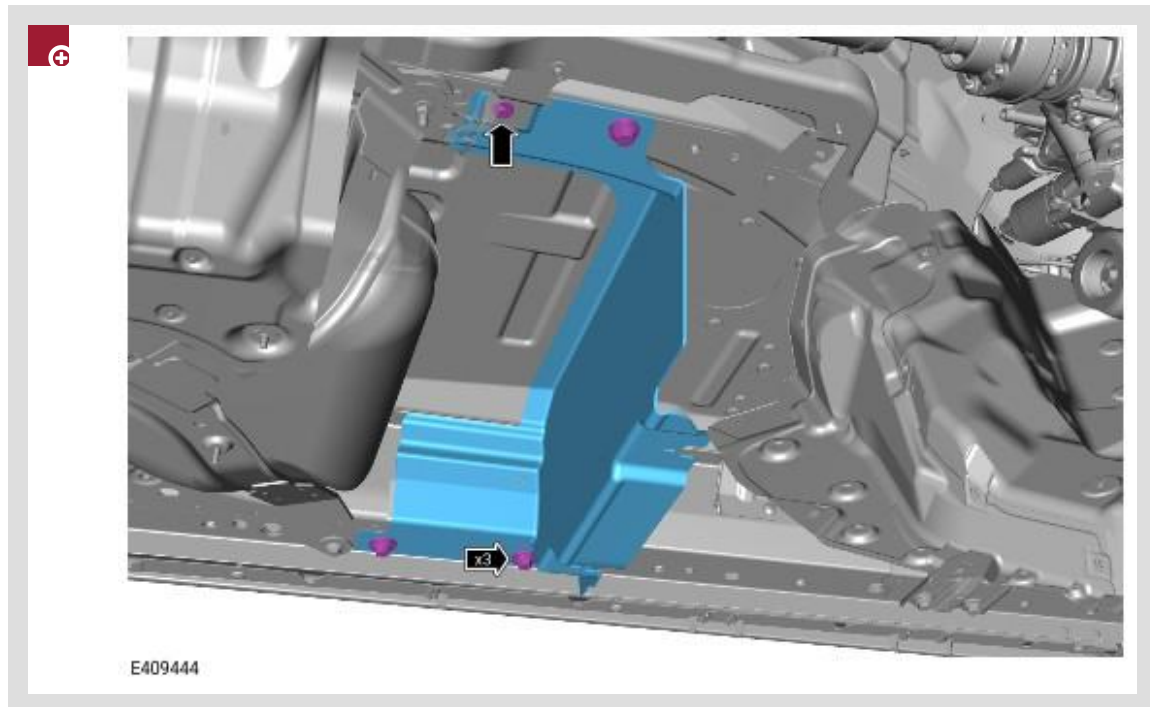

Install the left fuel tank heatshield deflector in the location shown in the illustration.

- Install the bolt previously removed.
 - Torque: **5Nm**

NOTE:

Apply a small amount medium strength thread lock to each bolt before installing the bolts.

Install the 3 new bolts (LR090632).

- Torque: **40Nm**

62.

NOTE:

This step is required for ALL V8 T/C 4.4L Petrol NC10 vehicles.

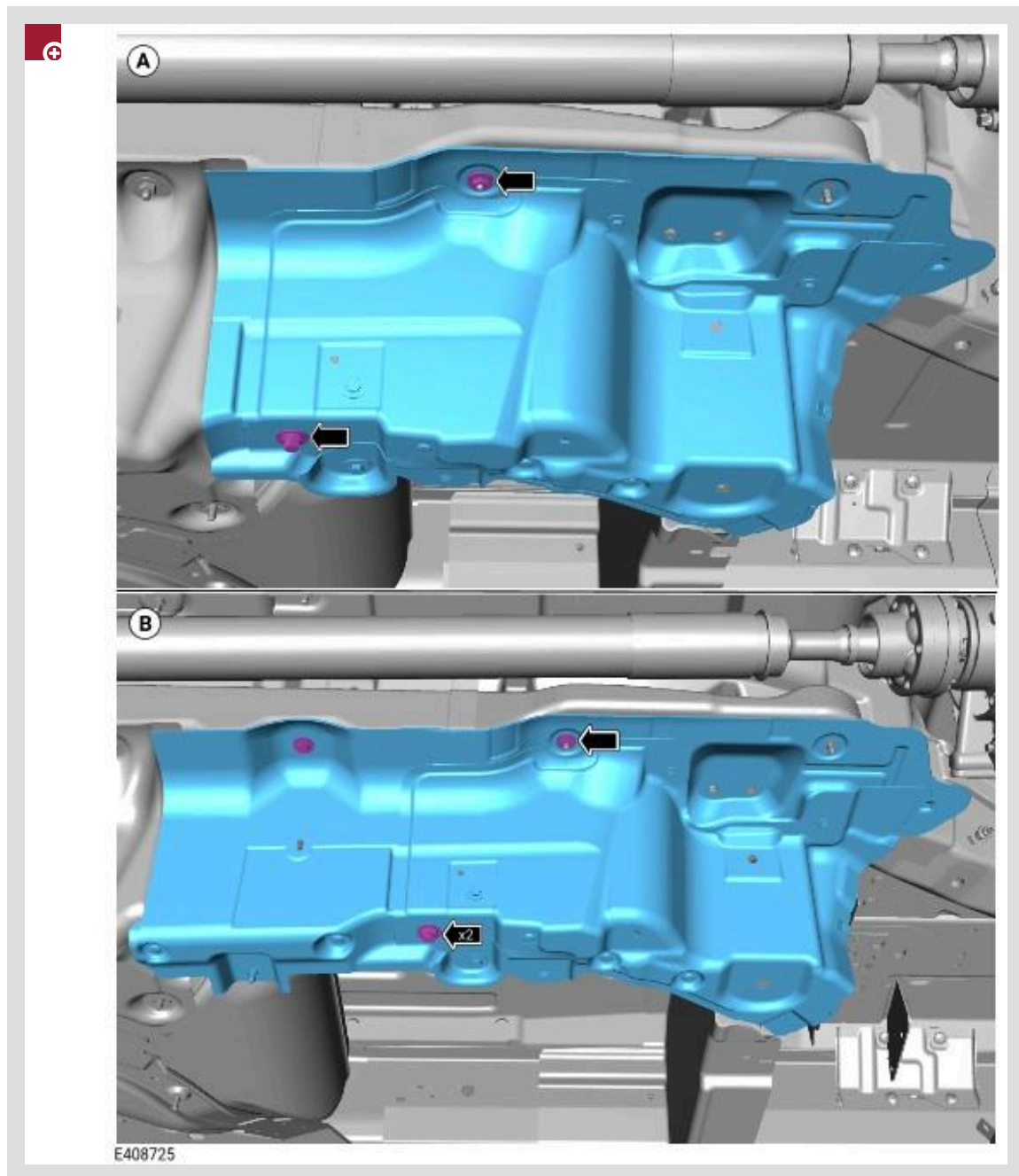

Refer to the applicable illustration for the installation of the new left center heatshield.

- **(A) SWB V8 T/C 4.4L Petrol NC10 vehicles** - Install the new left heatshield.
 - Install the nut previously removed.
 - Torque: **5Nm**
 - Install the bolt previously removed.
 - Torque: **5Nm**

- (B) LWB V8 T/C 4.4L Petrol NC10 vehicles - Install the new left heatshield.
 - Install the nut previously removed.
 - Torque: **5Nm**
 - Install the 2 bolts previously removed.
 - Torque: **5Nm**

63.

NOTE:

This step is required for ALL V8 T/C 4.4L Petrol NC10 vehicles.

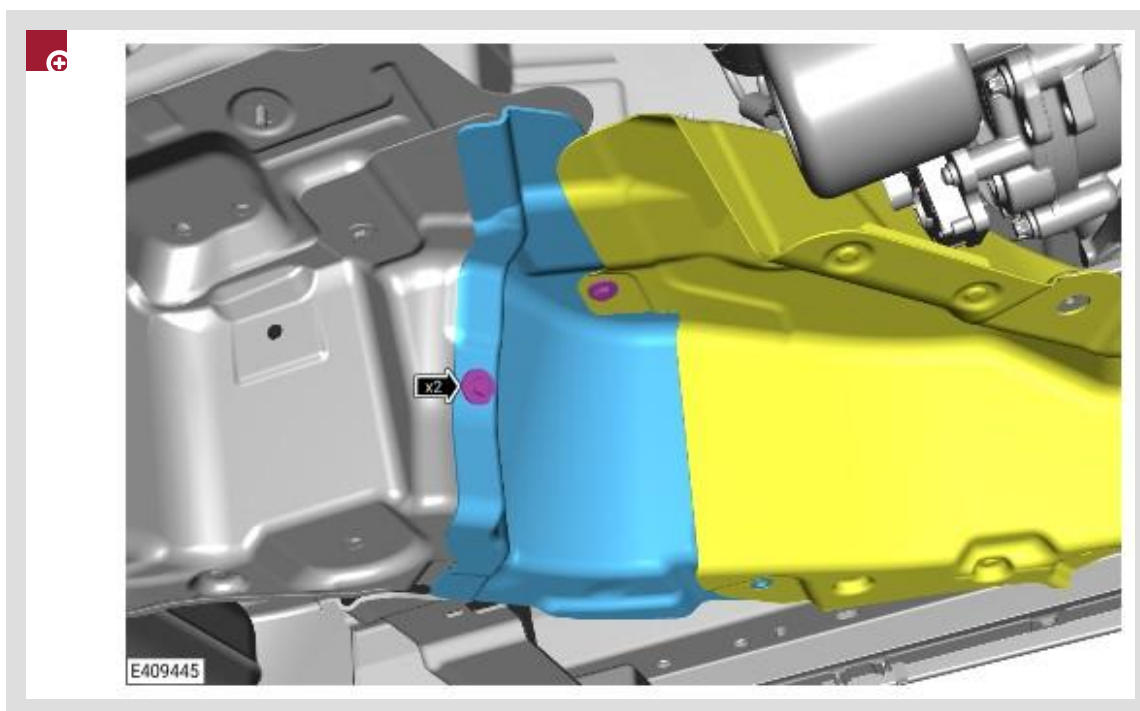

Install the left in-fill heatshield.

- Install the 2 bolts previously removed.
 - Torque: **5Nm**

64.

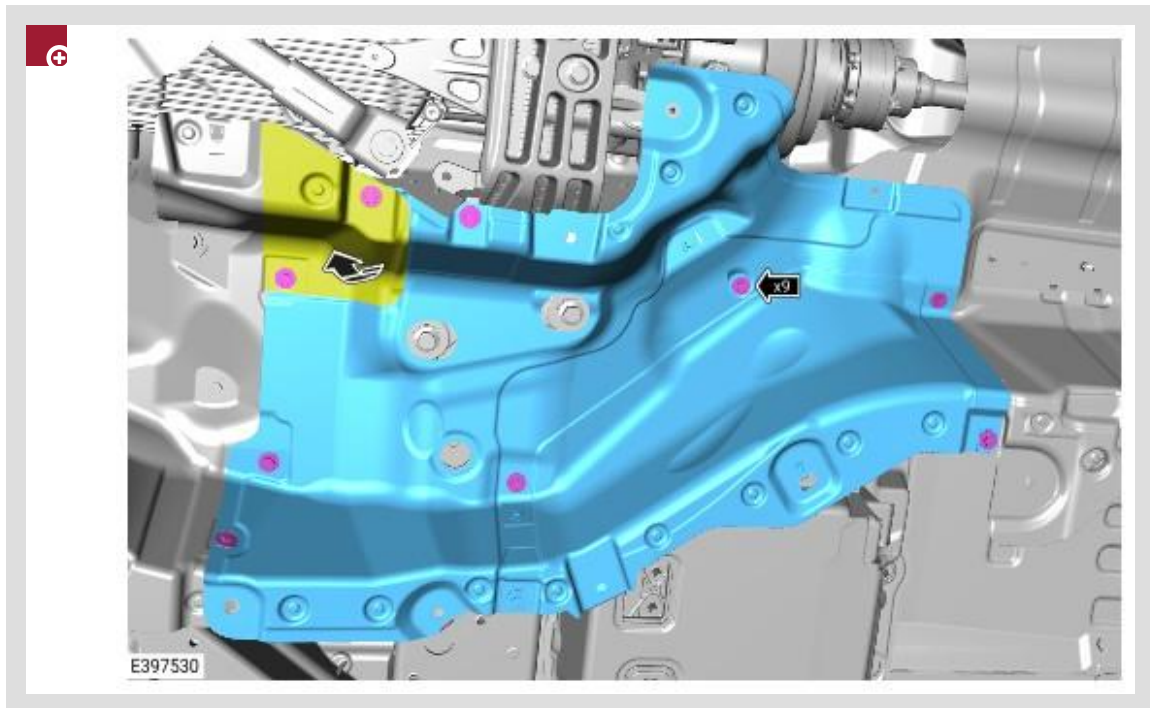

Follow the instruction below that is applicable to the specification of vehicle.

- **V8 T/C 4.4L Petrol NC10 vehicles** - Install a new right transfer case heatshield (LR184931).
 - Reposition the exhaust down pipe heatshield.
 - Install the 9 bolts previously removed.
 - Torque: **5Nm**
- **INGENIUM I6 3.0L Petrol / V8 T/C 4.4L Petrol NC11 vehicles** - Install the original right transfer case heatshield previously removed.
 - Reposition the exhaust down pipe heatshield.
 - Install the 9 bolts previously removed.
 - Torque: **5Nm**

65.

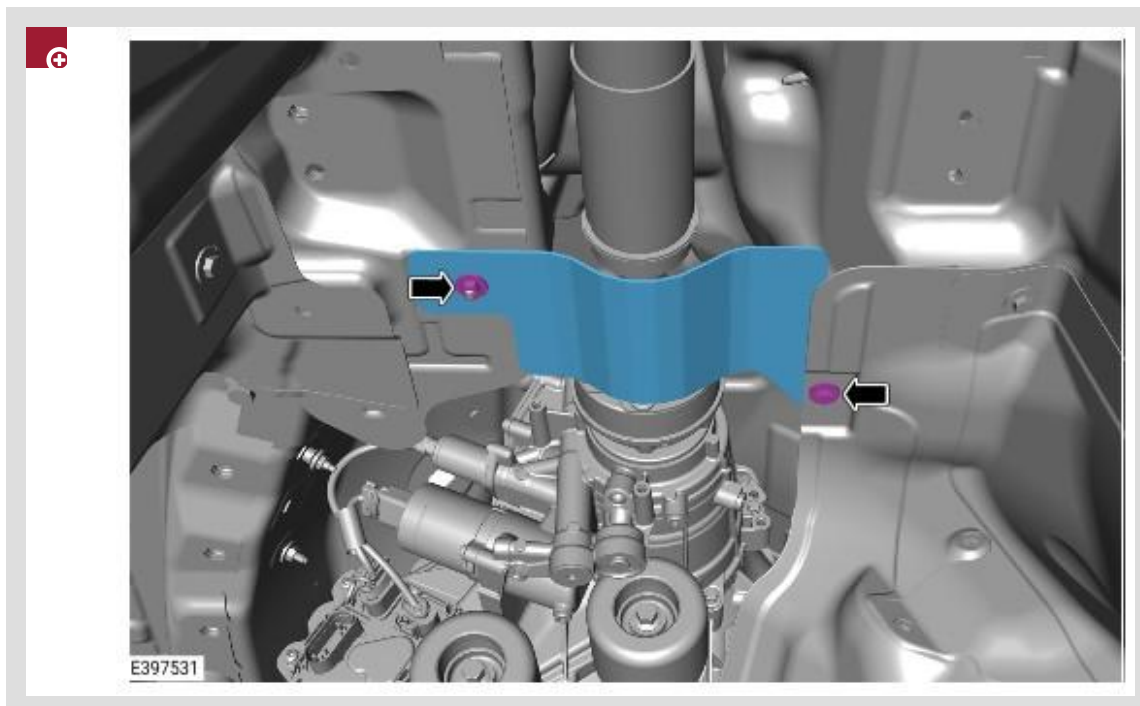

Install driveshaft universal joint heatshield.

- Install the nut previously removed.
 - Torque: **5Nm**
- Install a new bolt (AYP500110)
 - Torque: **5Nm**

66.

Install the exhaust system (see TOPIx Workshop Manual section 309-00: Exhaust System - Removal and Installation - Exhaust).

67.

NOTE:

SWB shown but LWB is similar.

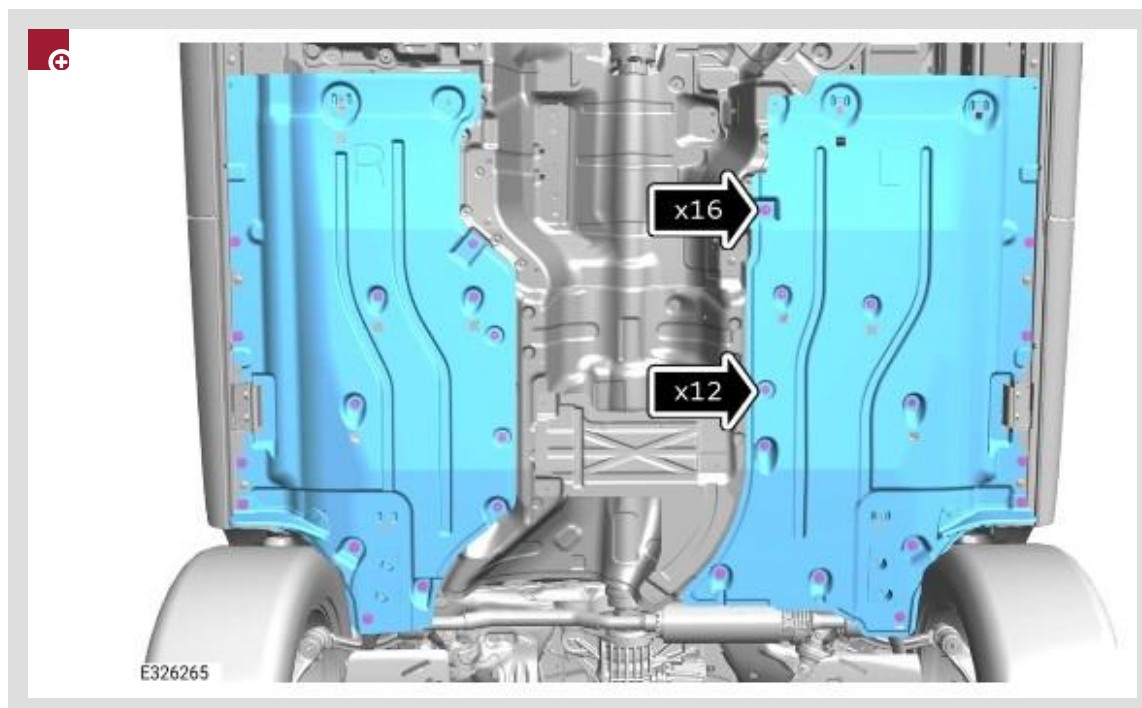

Install the left and right undershield.

- Install the 12 nuts.
 - Torque: **5Nm**
- Install the 16 bolts.
 - Torque: **5Nm**

V8 T/C 4.4L Petrol (NC10 / NC11) Vehicles Only

68.

NOTE:

If a single piece transmission undershield was discarded, a new 3 piece transmission undershield must be installed.

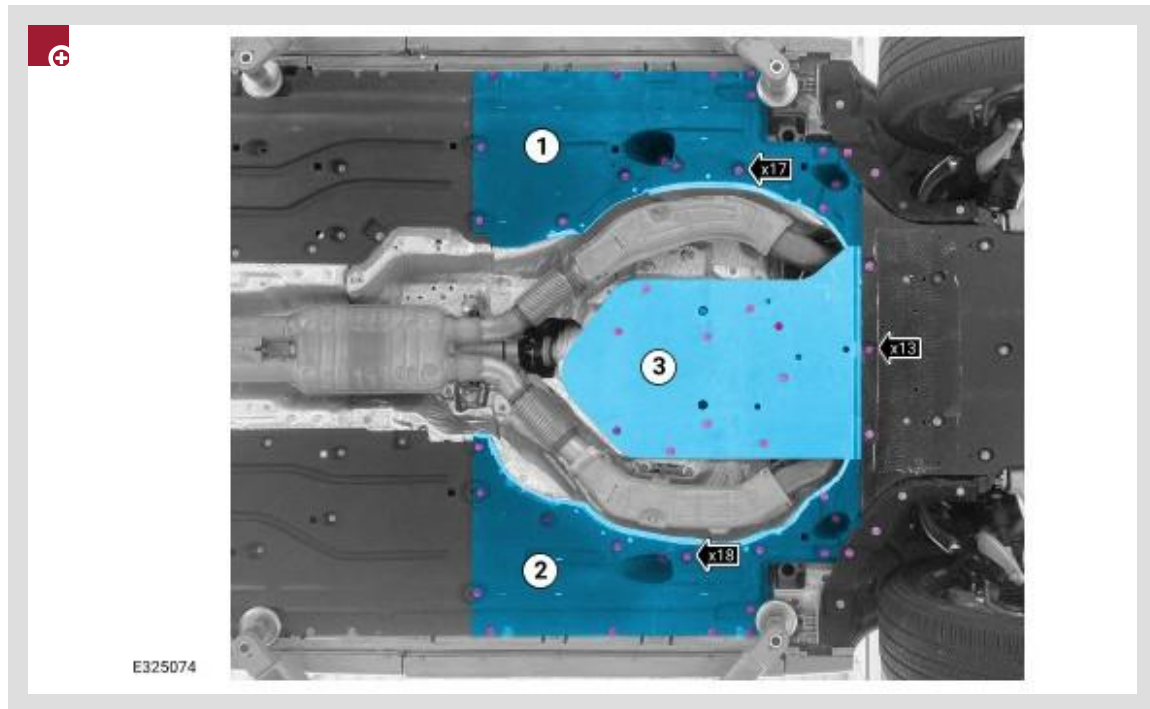

Install the new 3 piece transmission undershield.

1. Install the right transmission undershield section.
 - Install the 17 bolts.
 - Torque: **5.4Nm**
2. Install the left transmission undershield section.
 - Install the 18 bolts.
 - Torque: **5.4Nm**
3. Install the center transmission undershield section.
 - Install the 13 bolts.
 - Torque: **5.4Nm**

INGENIUM I6 3.0L Petrol Vehicles Only

69.

NOTE:

If a single piece transmission undershield was discarded, a new 3 piece transmission undershield must be installed.

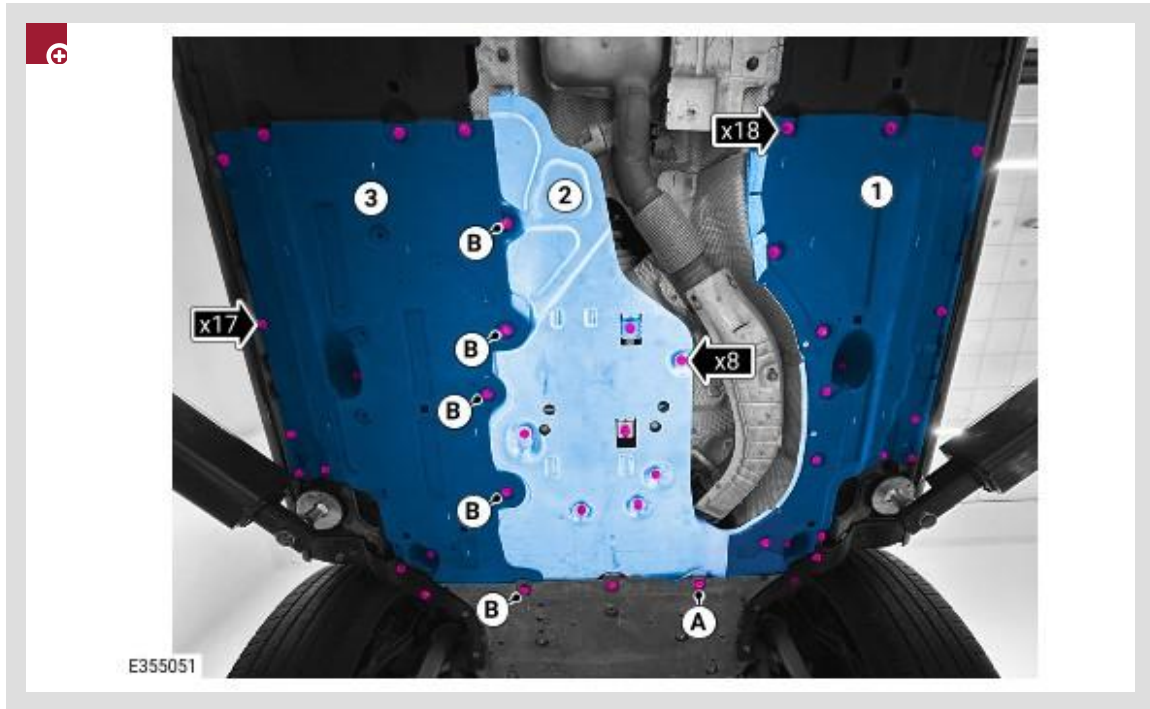

Install the 3 piece transmission undershield.

▪ **NOTE:**

Do not install the bolt marked 'A' in the illustration at this stage.

Install the right transmission undershield section.

- Install the 18 bolts.
 - Torque: **5.4Nm**

▪ **NOTES:**

- Do not install the bolts marked 'B' in the illustration at this stage.
- Install the bolt marked 'A' in the illustration at this stage.

Install the center transmission undershield section.

- Install the 8 bolts.
 - Torque: **5.4Nm**

▪ **NOTE:**

Install the bolts marked 'B' in the illustration at this stage.

Install the left transmission undershield section.

- Install the 17 bolts.
 - Torque: **5.4Nm**

All Vehicles

70. Continue to install the startup battery housing (see TOPIx Workshop Manual section 414-01: Battery, Mounting and Cables - Removal and Installation - Startup Battery Housing - **From Installation Step 7**).

71. Continue to **Service Instruction B**.

SERVICE INSTRUCTION B - REAR HVAC DRAIN

NOTES:

- **This Service Instruction is divided into 3 sections:**
- **Range Rover Sport Vehicles**
- **Range Rover 7 Seat Vehicles**
- **Range Rover 5 Seat / Executive Seat Vehicles**
- **Always review the Service Instruction prior to starting the repair to confirm the correct steps for the vehicle.**
- Some components shown removed for clarity.
- Some variation in the illustrations may occur, but the essential information is always correct.

Range Rover Sport Vehicles Only

1. Open the left rear door.

2.

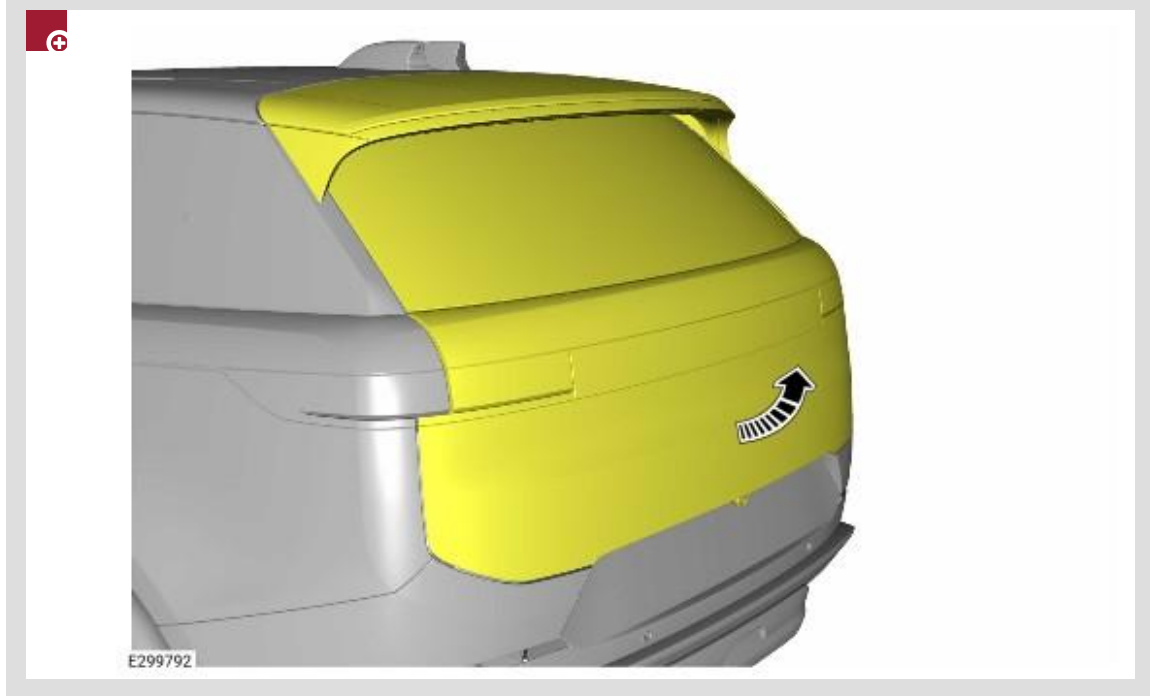

Open the tailgate.

3.

Remove the left Loadspace Trim Panel (see TOPIx Workshop Manual section 501-05: Interior Trim and Ornamentation - Loadspace Trim Panel).

4.

NOTE:

If equipped.

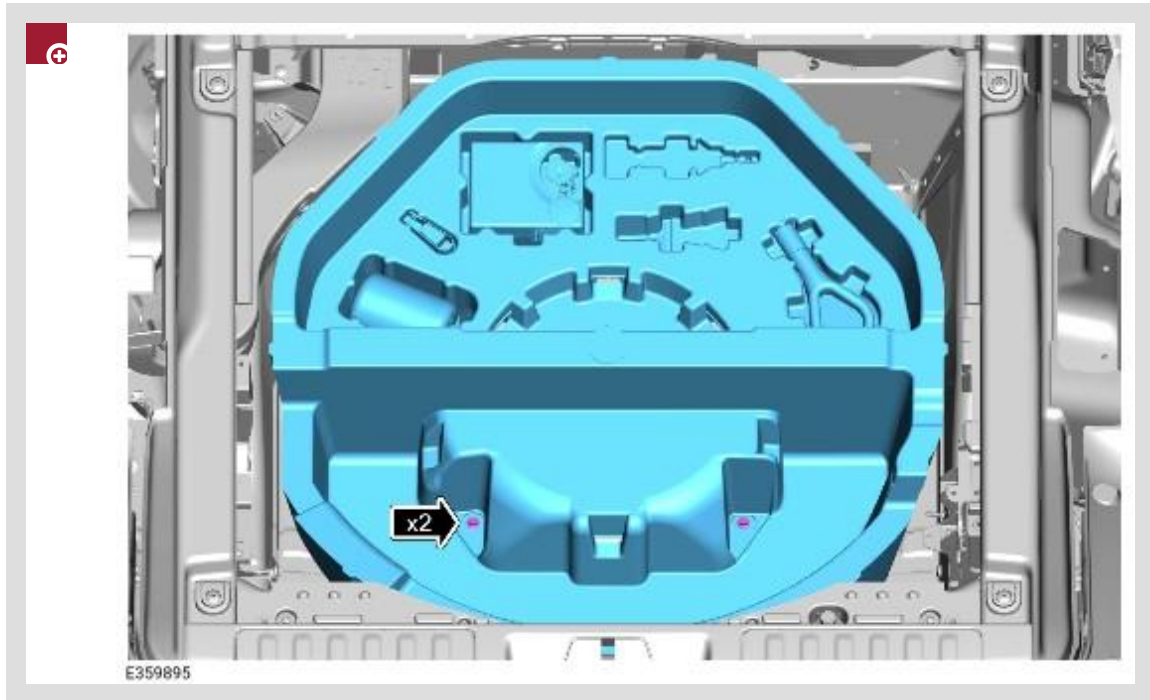

Remove the foam tray.

- Remove the 2 bolts.
 - Torque: **27.5Nm**

5.

 **NOTE:**

If equipped.

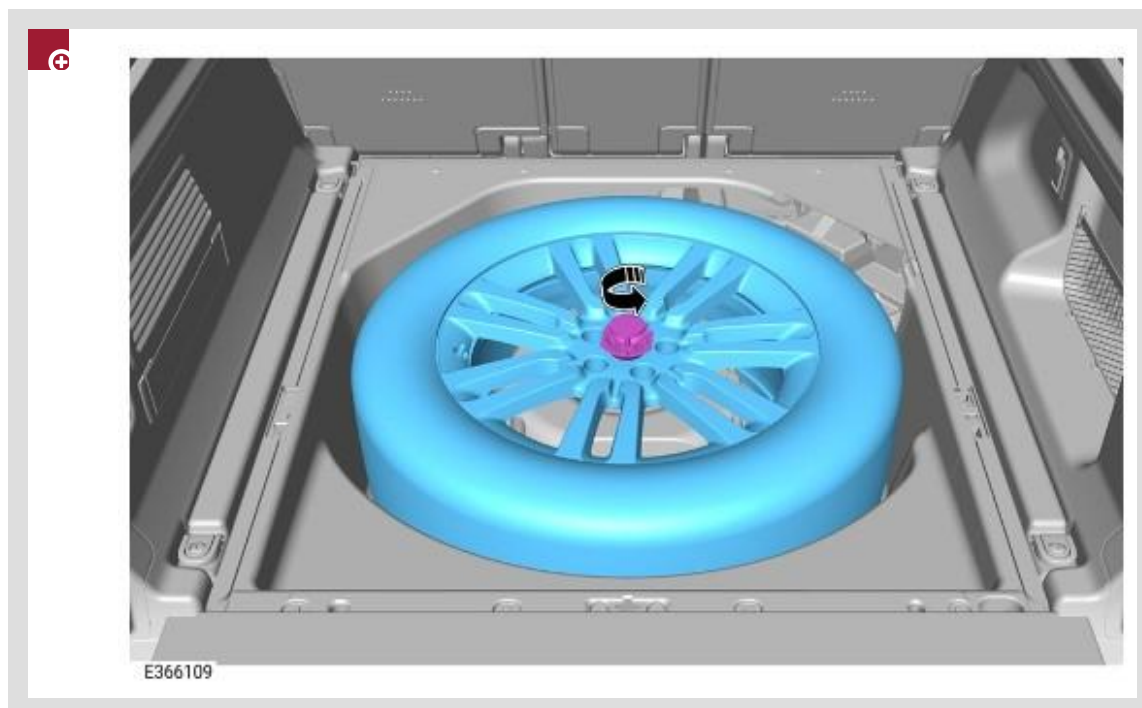

Remove the spare wheel.

6.

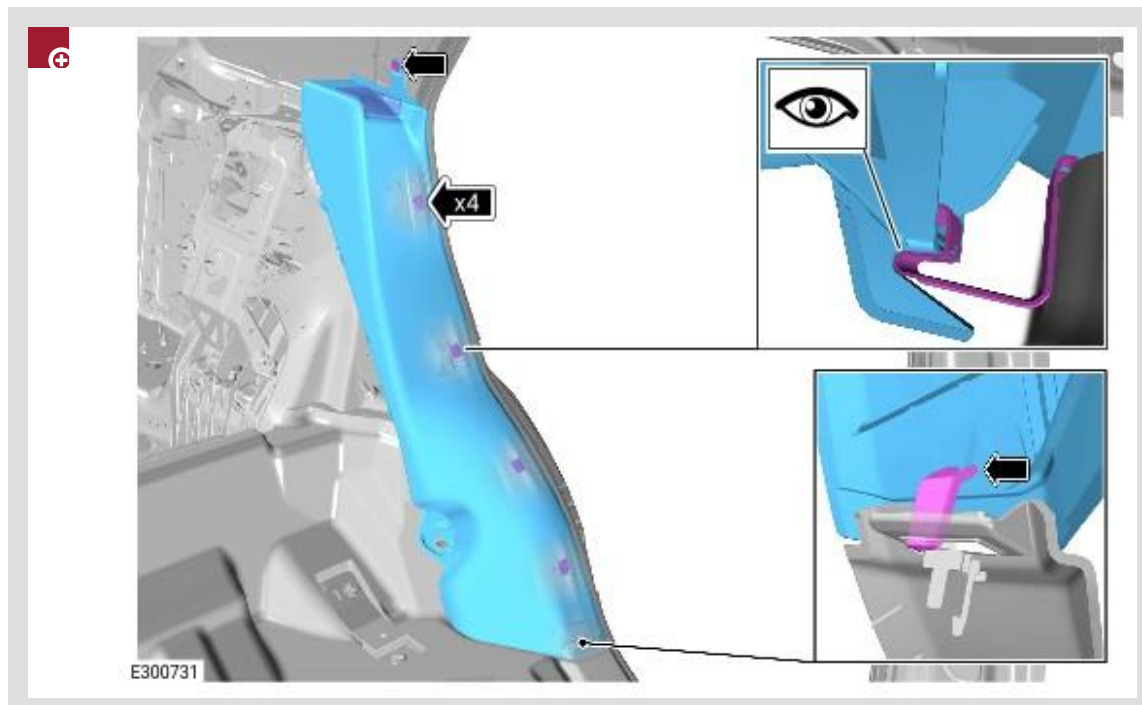

Remove the C-pillar lower trim panel.

- Remove the bolt.
 - Torque: **5Nm**
- Release the 5 clips.

7.

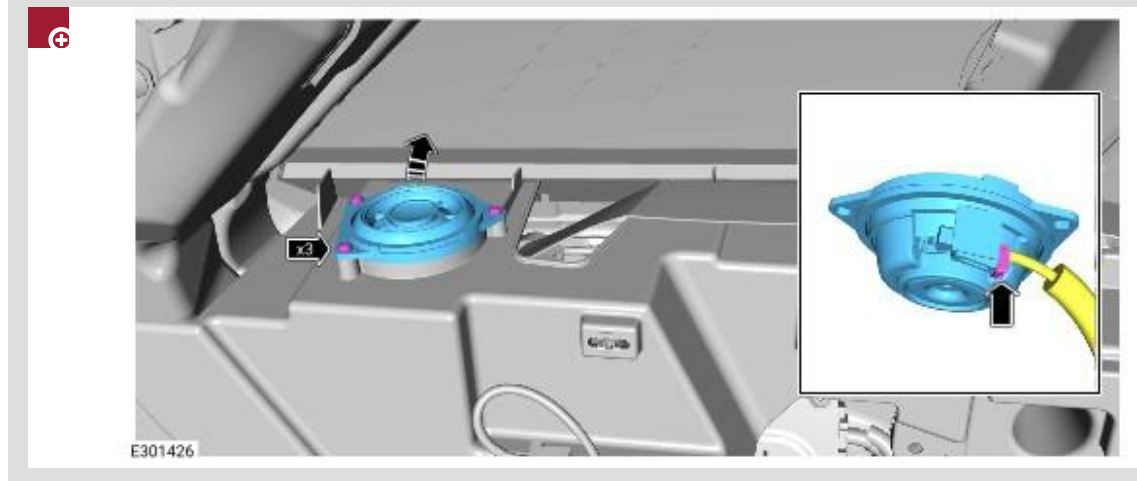

Remove the loadspace speaker.

- Remove the 3 screws.
- Disconnect the electrical connector.

8.

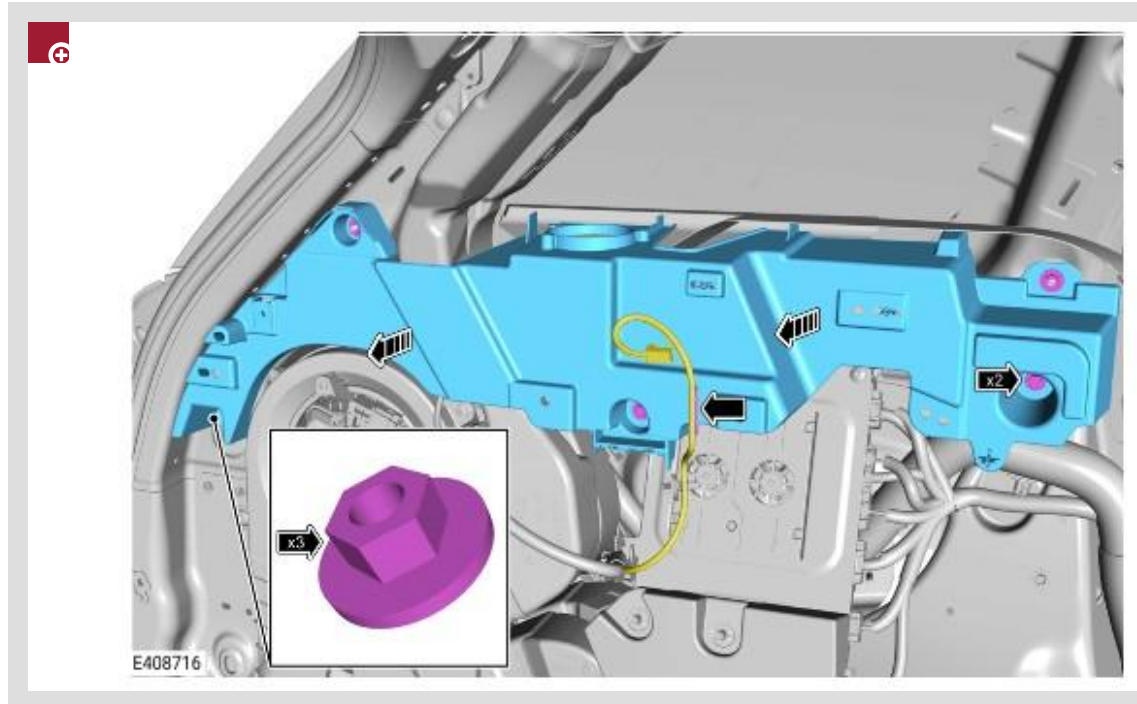

Remove the left upper loadspace bracket.

- Remove the 3 nuts.
 - Torque: **5Nm**
- Remove the 2 bolts.
 - Torque: **5Nm**
- Release the clip.

9.

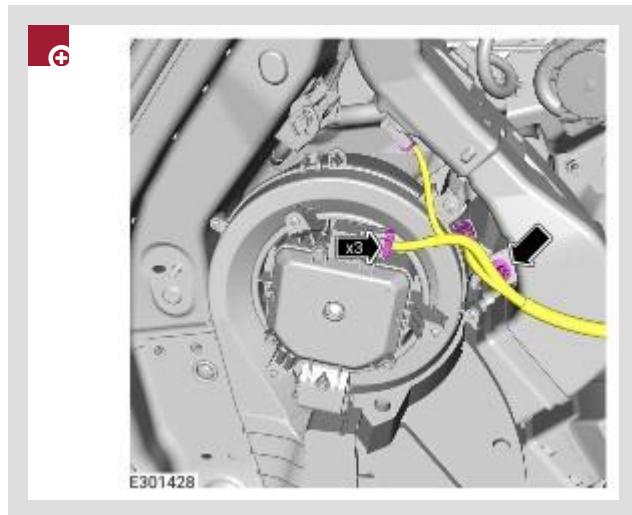

Release the wiring harness.

- Disconnect the 3 electrical connectors.
- Release the clip.

10.

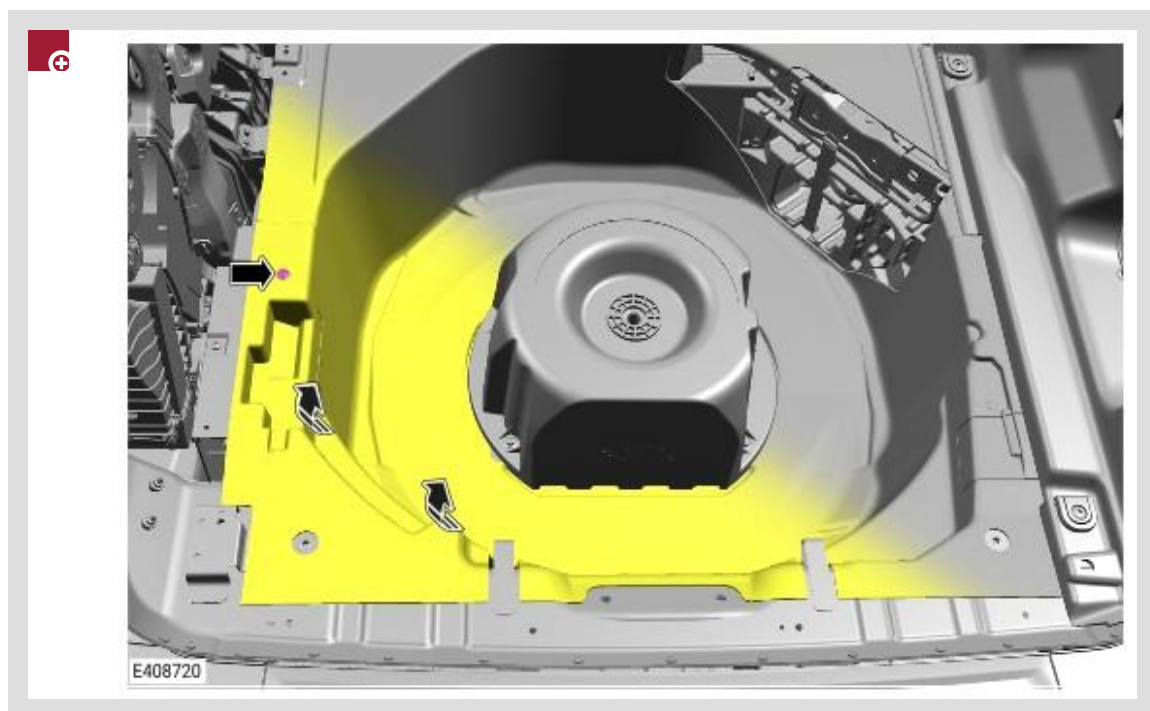

Reposition the loadspace floor carpet.

- Remove the fir tree clip.

11.

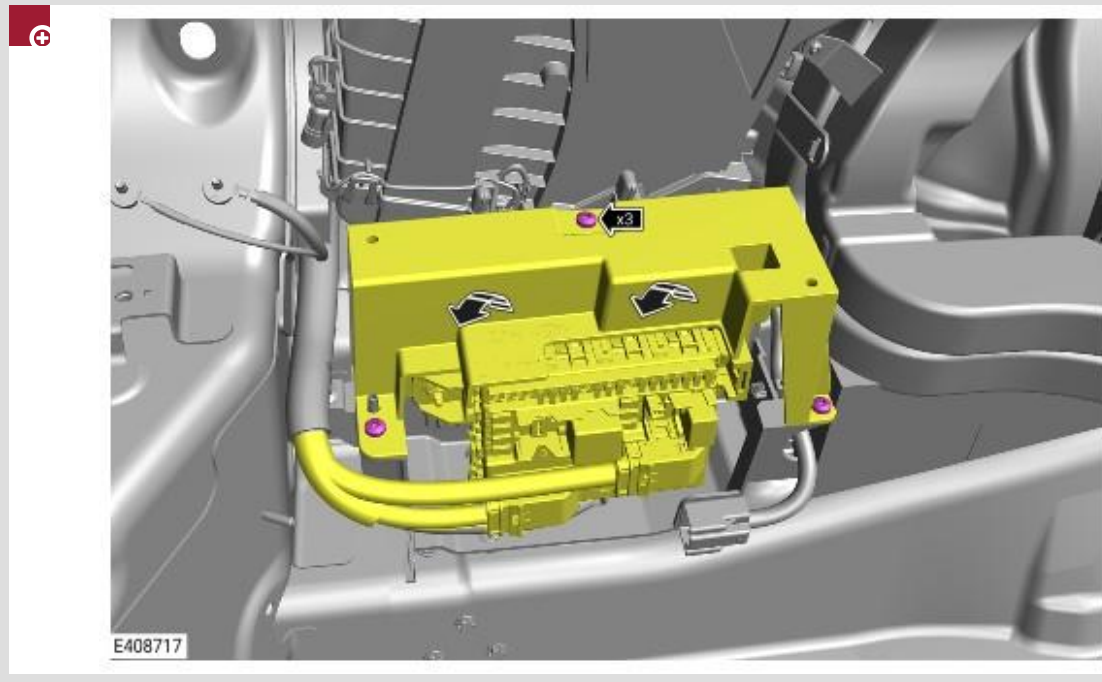

Reposition the Rear Junction Box (RJB) assembly for access.

- Remove the 3 bolts.
 - Torque: **5Nm**

12.

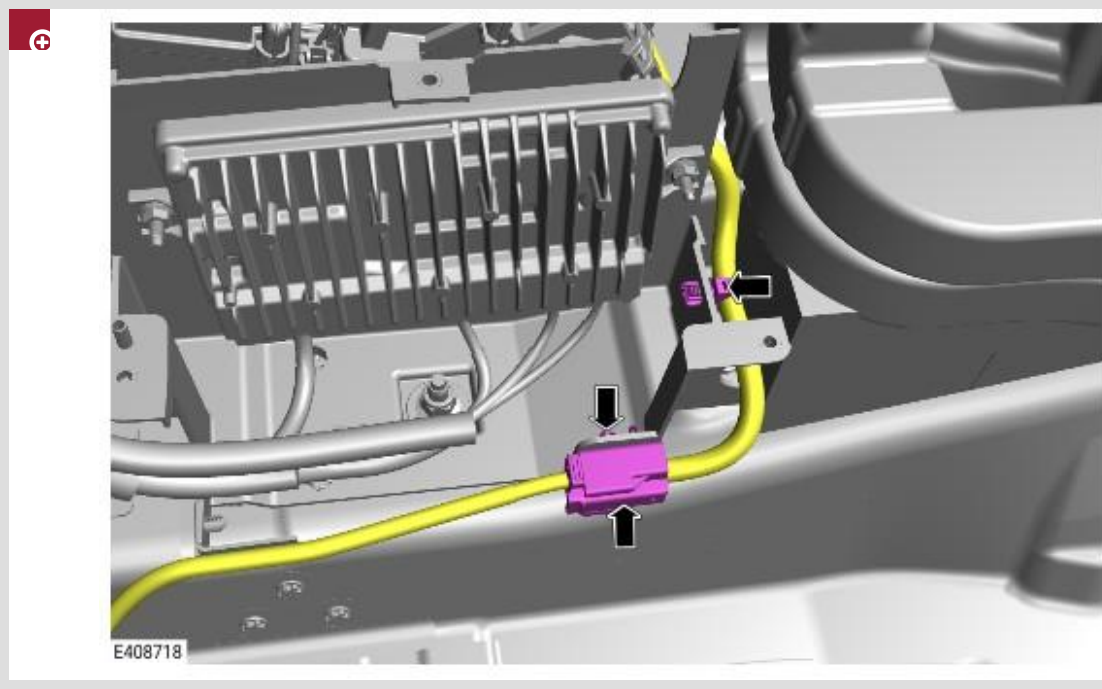

Reposition the towbar wiring harness for access.

- Disconnect the electrical connector.
 - Release the electrical connector clip.
- Release the clip.

13.

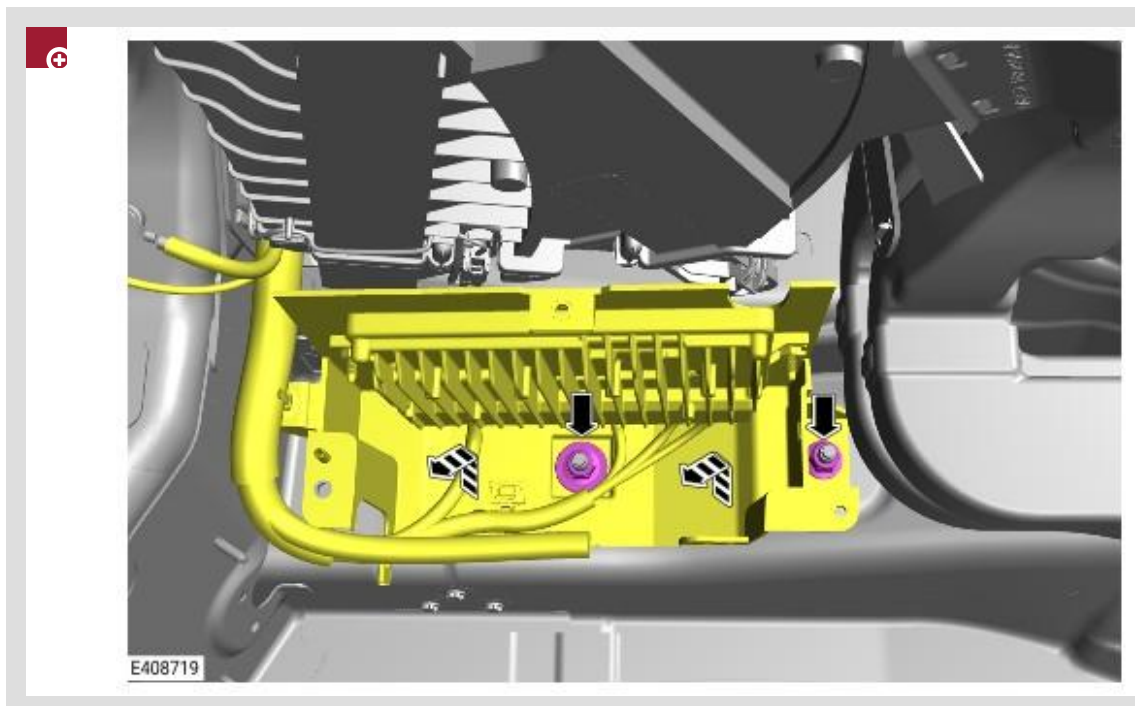

Reposition the Near Field Sensing Module (NFSM) assembly.

- Remove the 2 nuts.
 - Torque: **48Nm**

14.

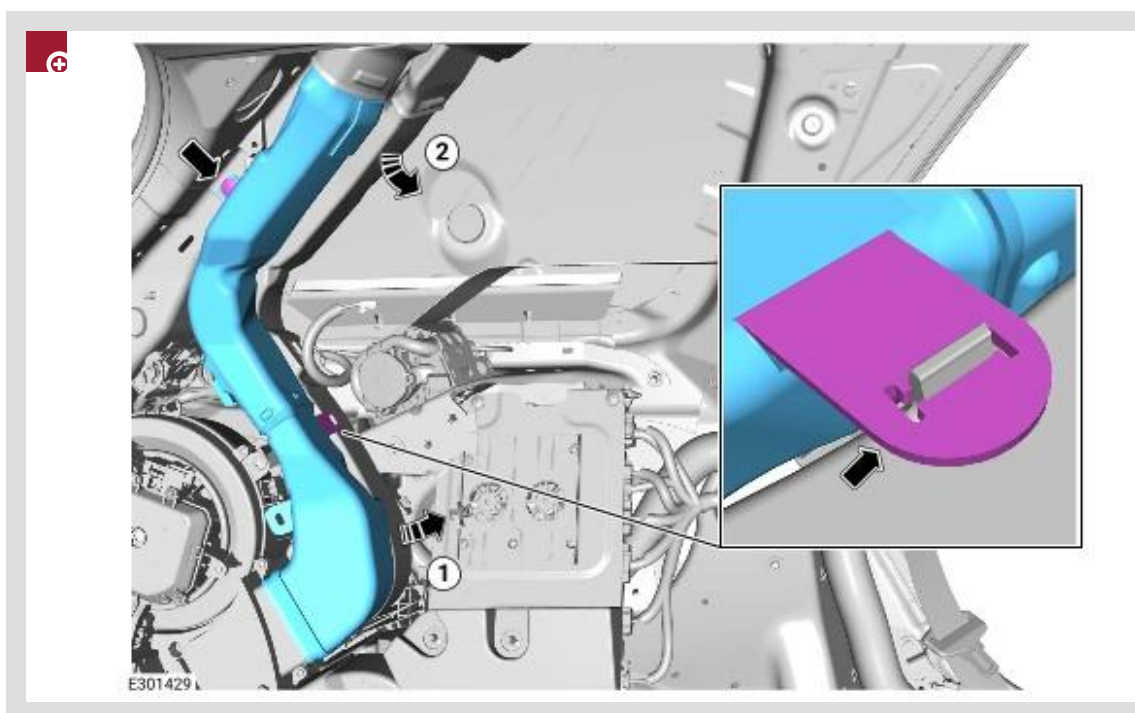

Remove the air duct in the sequence shown in the illustration.

- Release the clip.
- Remove the fir tree clip.

15.

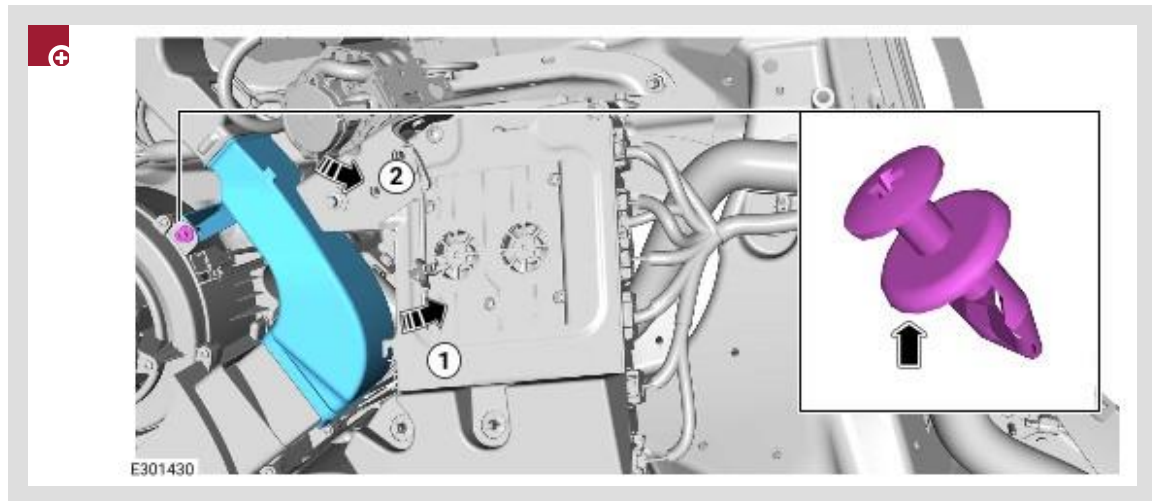

Remove the air duct in the sequence shown in the illustration.

- Remove the scrivet.

16.

⚠ CAUTION:

Only raise the auxiliary climate control assembly high enough to access the drain grommet (approximately 25 mm). Failure to follow this instruction may lead to damage to the component.

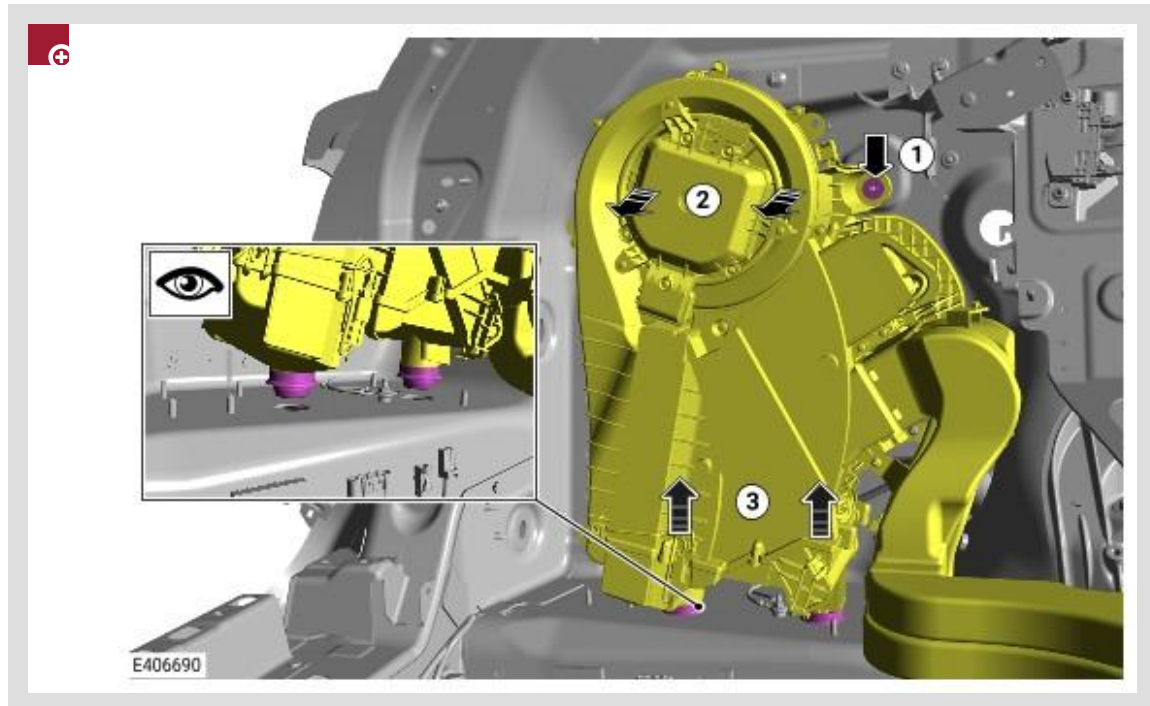

Raise the auxiliary climate control assembly to allow access to the drain grommet.

1. Remove the nut.
 - Torque: **5Nm**
2. Pull the top of the auxiliary climate control assembly forward to release it from the stud.
3. Raise the auxiliary climate control assembly.

17.

NOTE:

Only remove the drain grommet shown in the illustration. The grommet further forward on the auxiliary climate control assembly is for location purposes only.

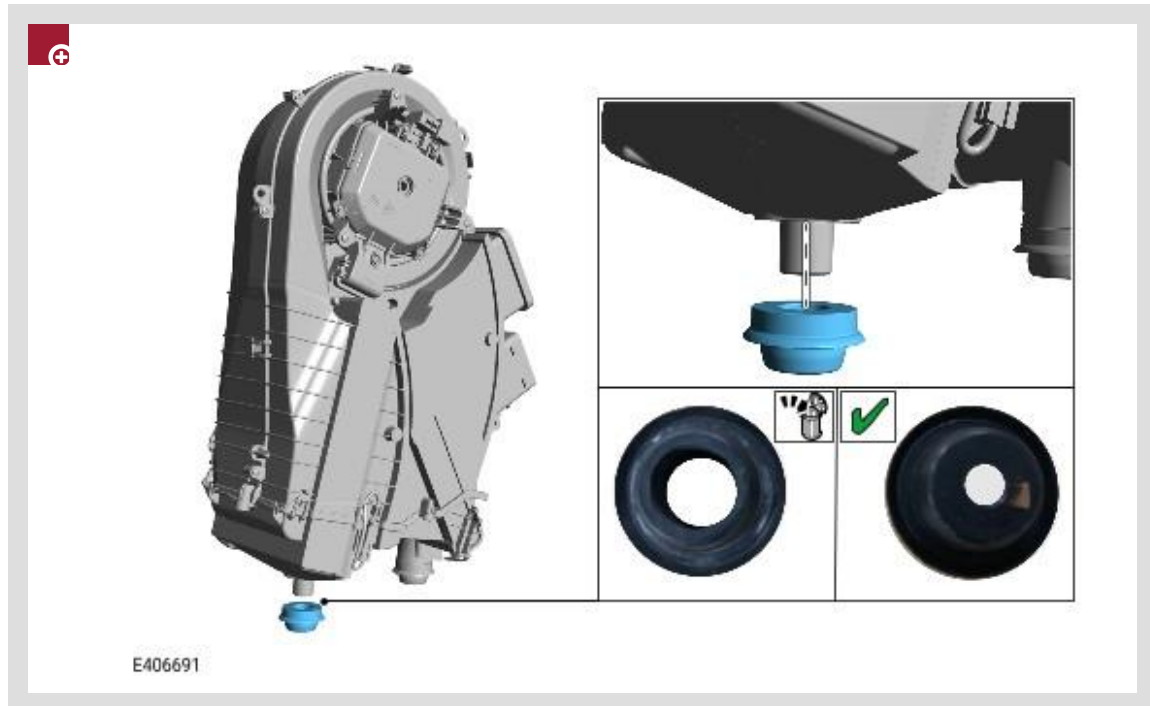

Renew the drain grommet shown in the illustration.

- Remove and discard the drain grommet.
- Install the new reduced inner diameter drain grommet, shown with the **GREEN ✓** in the illustration.

18. Reverse steps 1 - 16.

Range Rover 7 Seat Vehicles Only

19. Open the left rear door.

20.

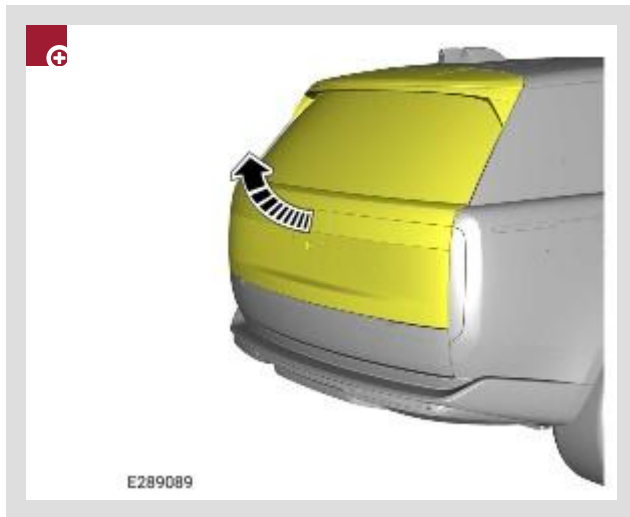

Open the upper tailgate.

21.



Open the lower tailgate.

22.

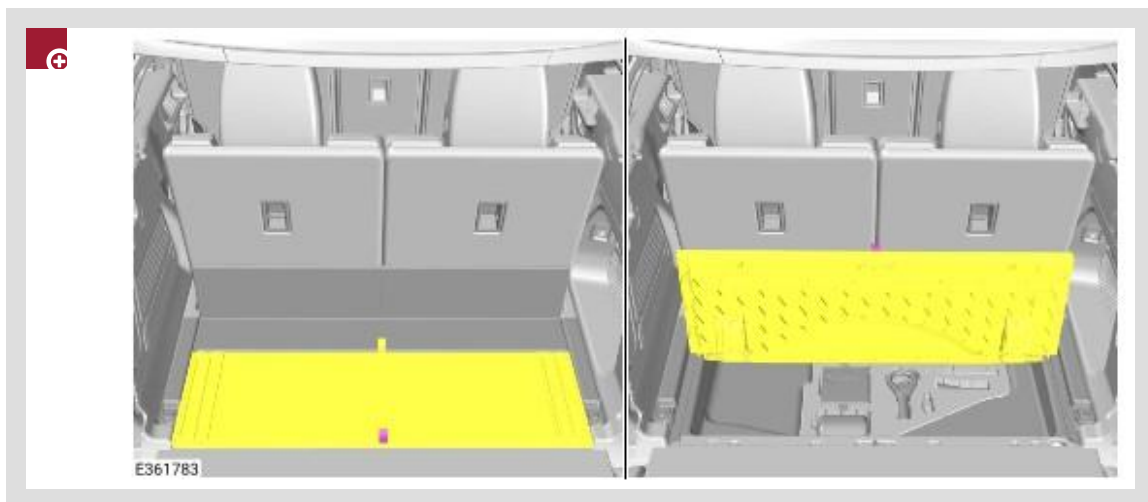

Open the smart loadspace compartment floor.

23.

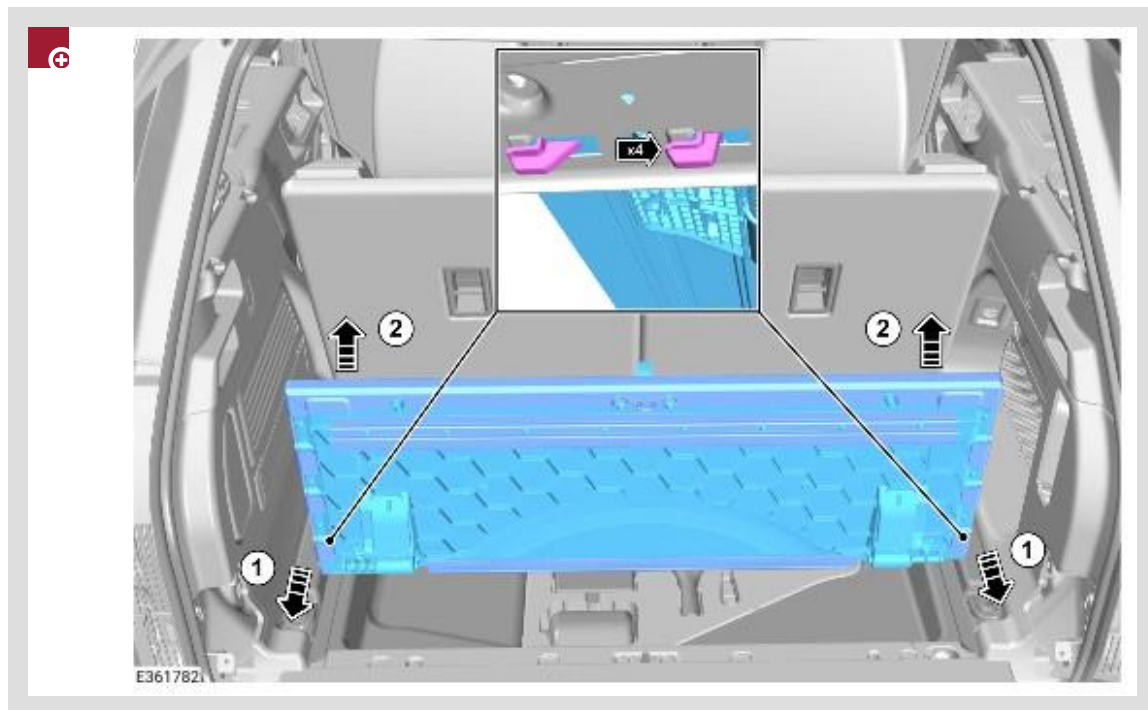

Remove the smart loadspace compartment floor in the sequence shown in the illustration.

24.

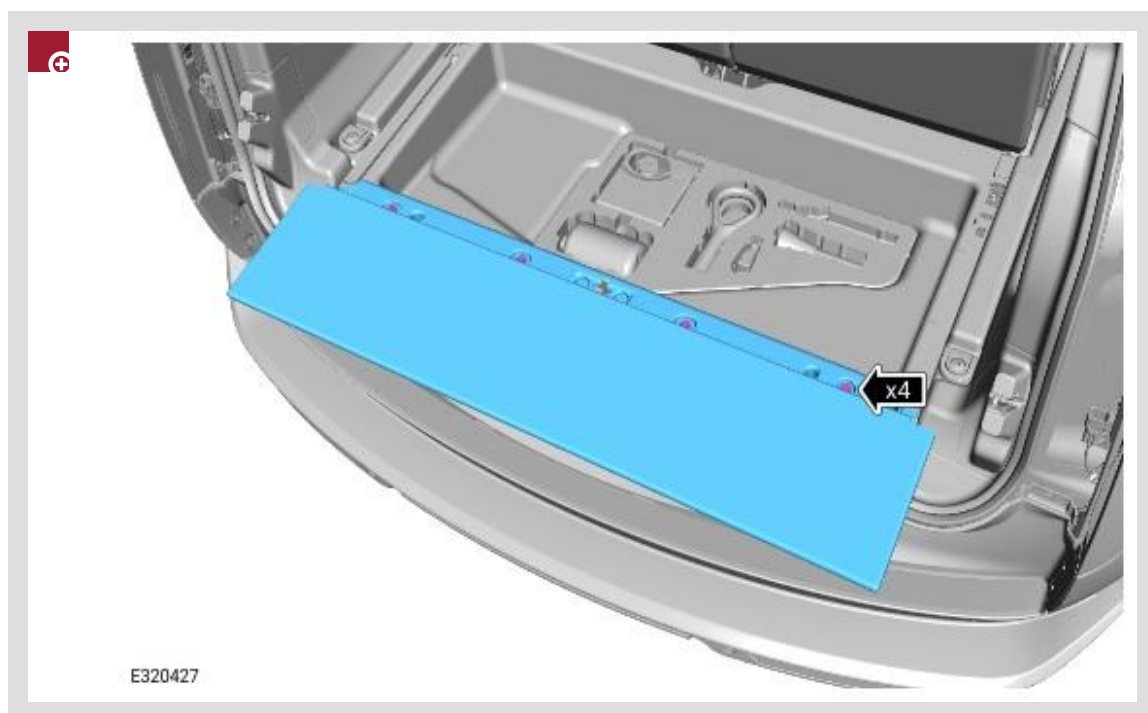

Remove the active load space cover.

- Remove the 4 bolts.
- Torque: **7Nm**

25.

Remove the left Loadspace Trim Panel (see TOPlx Workshop Manual section 501-05: Interior Trim and Ornamentation - Loadspace Trim Panel - Vehicles With: 7 Seats).

26.

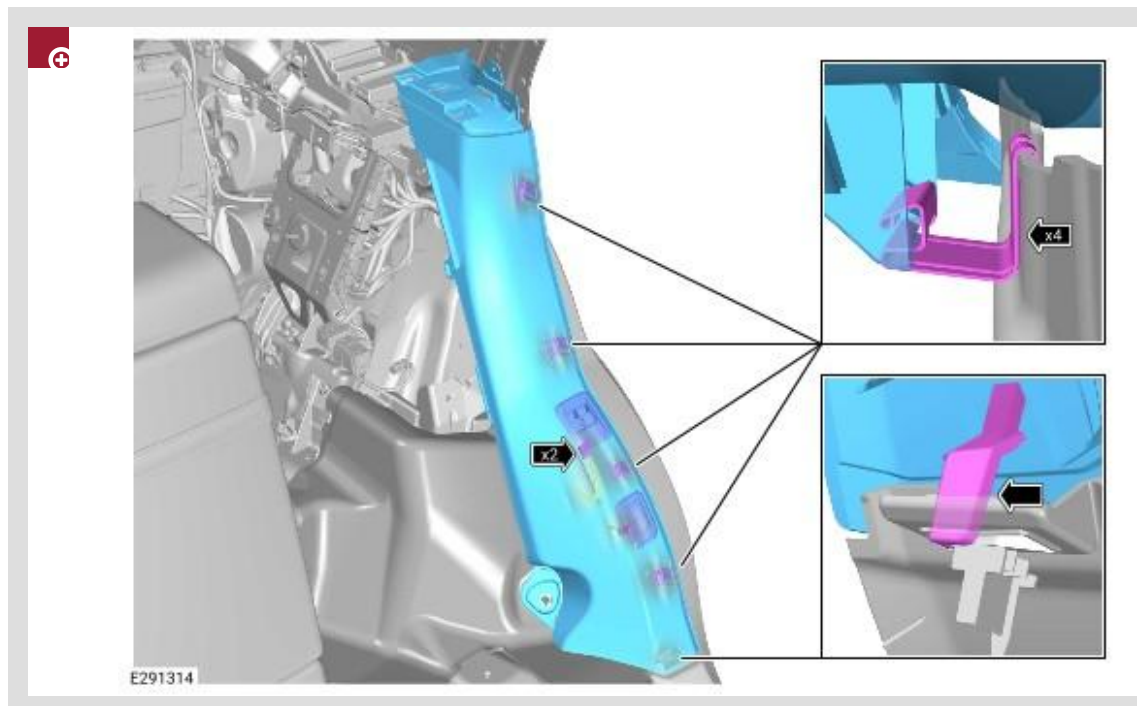

Remove the C-pillar lower trim panel.

- Disconnect the electrical connector.
- Release the 5 clips.

27.

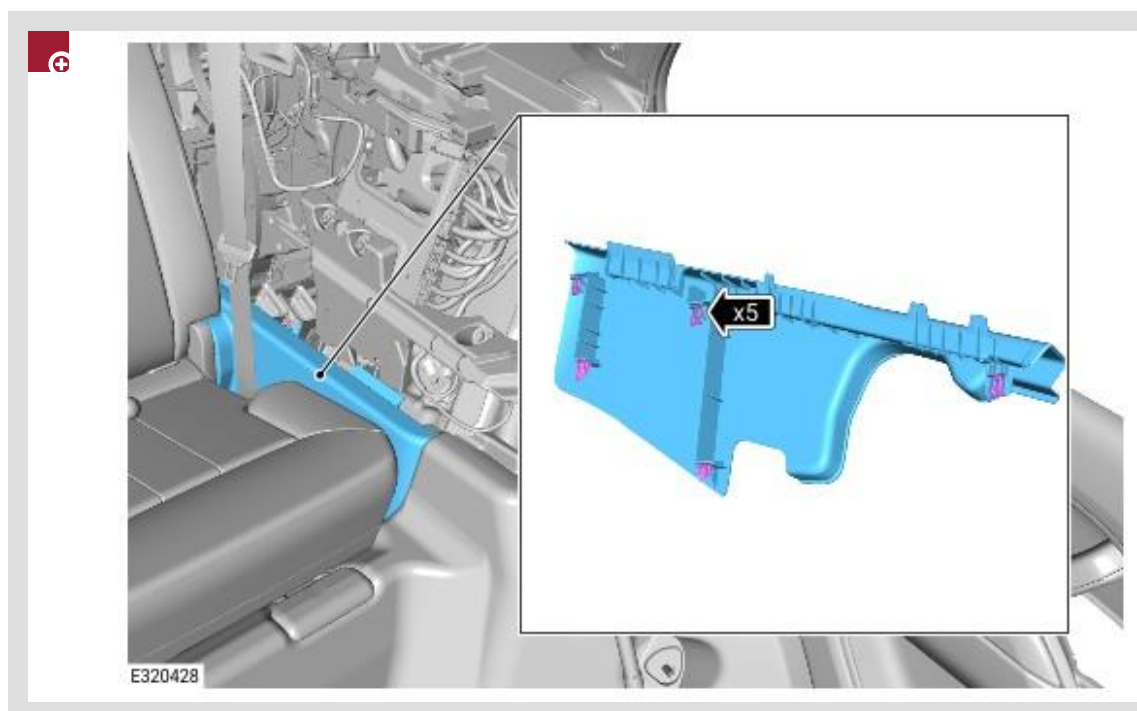

Remove the loadspace front side rail.

- Release the 5 clips.

28.

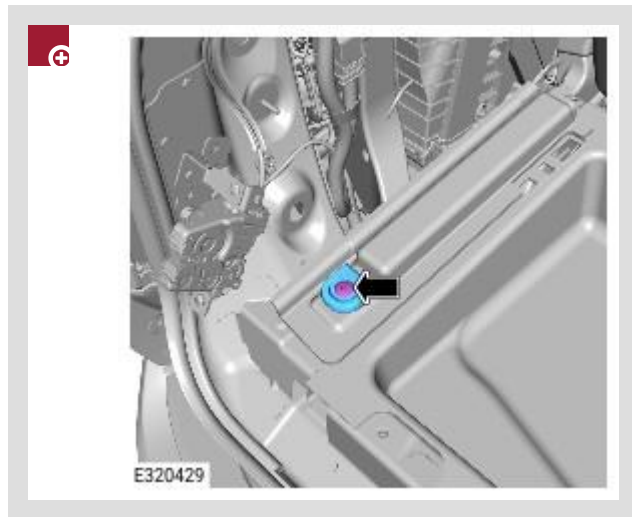

Remove the D-loop anchor point.

- Remove the bolt.
 - Torque: **24Nm**

29.

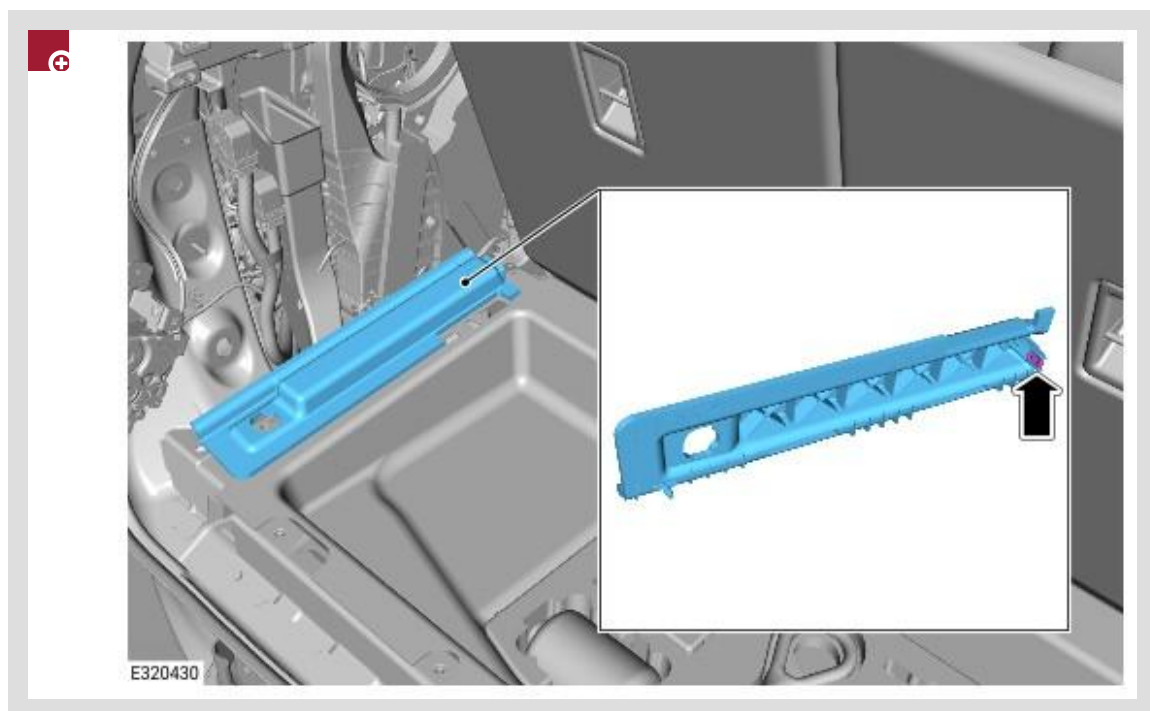

Remove the loadspace side rail.

- Release the clip.

30.

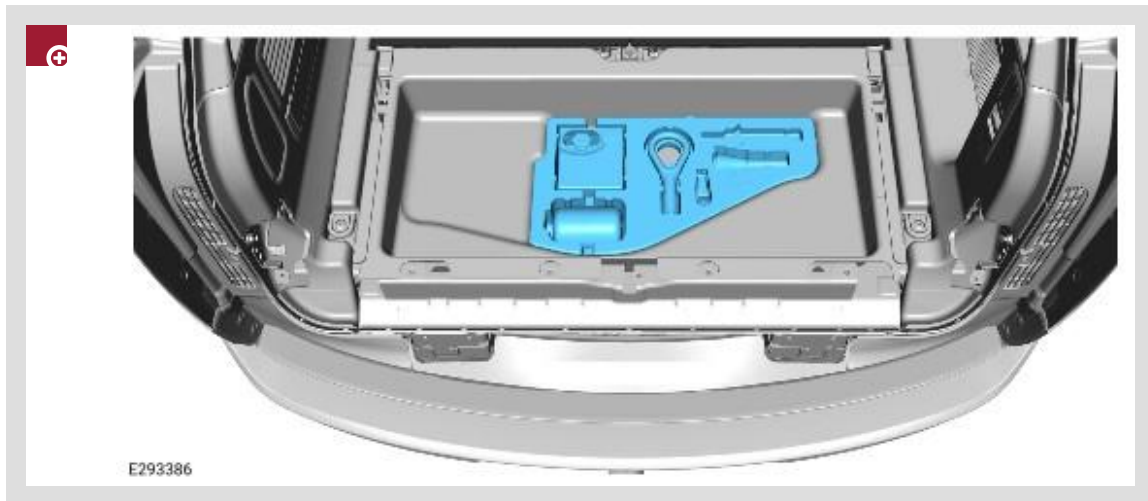

Remove the tool kit.

31.

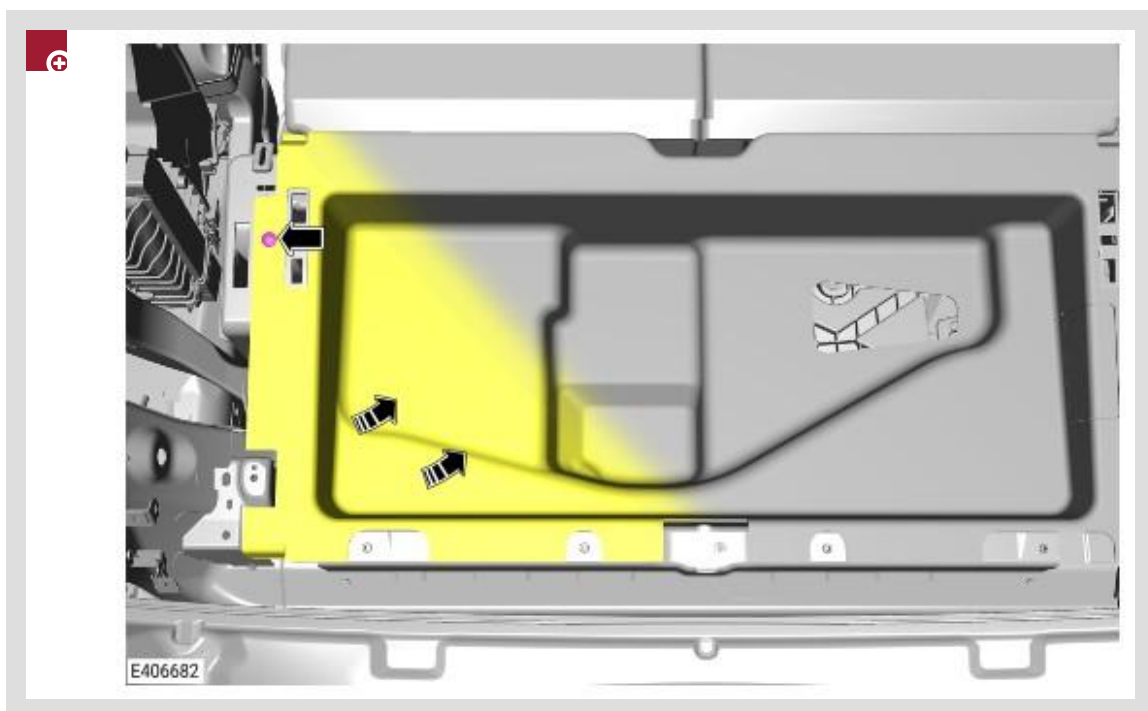

Reposition the loadspace floor carpet.

- Remove the fir tree clip.

32.



Remove the bracket.

- Remove the 4 bolts.
 - Torque: **5Nm**

33.

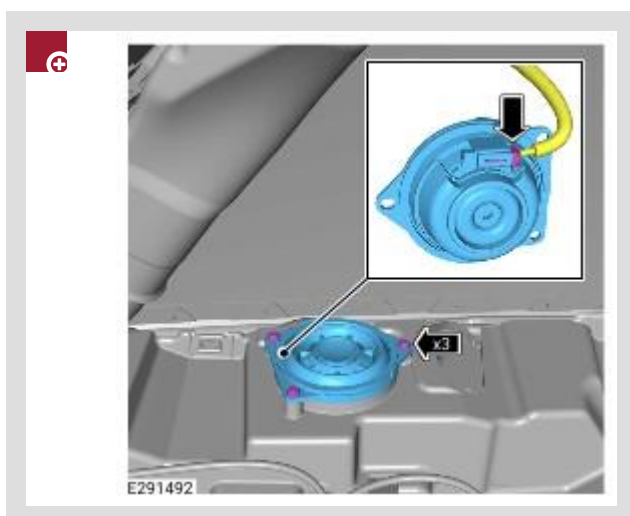

Remove the loadspace speaker.

- Remove the 3 screws.
- Disconnect the electrical connector.

34.

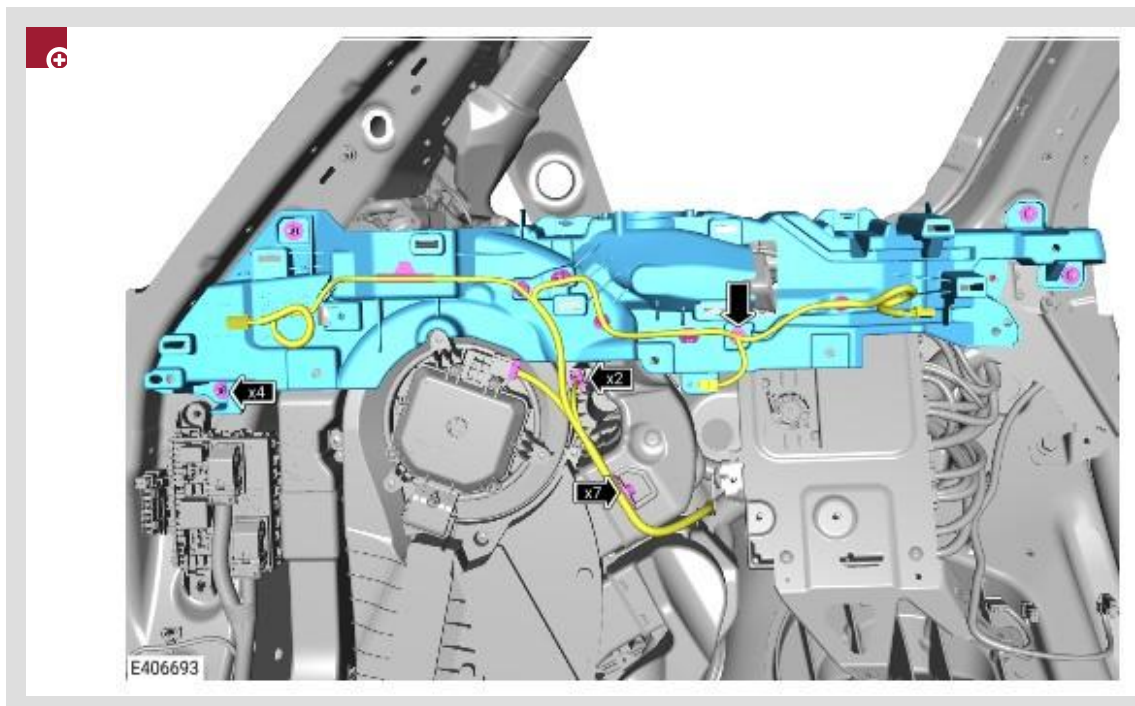

Remove the left upper loadspace bracket.

- Release the 7 wiring harness clips.
- Disconnect the 2 electrical connectors.
- Remove the 4 nuts and the 1 bolt.
 - Torque: **5Nm**

Range Rover 7 Seat Vehicles Without Hot Market Specification Air Ducts

35.

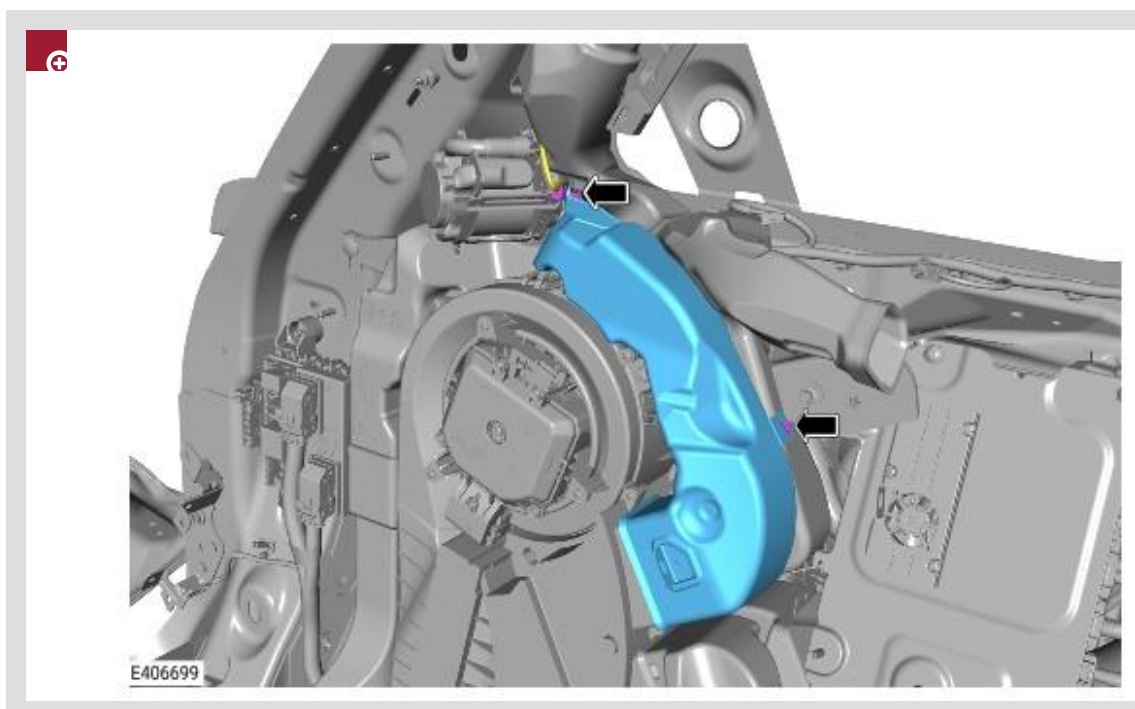

Remove the air duct.

- Release the clip.
- Release the wiring harness clip.

36.

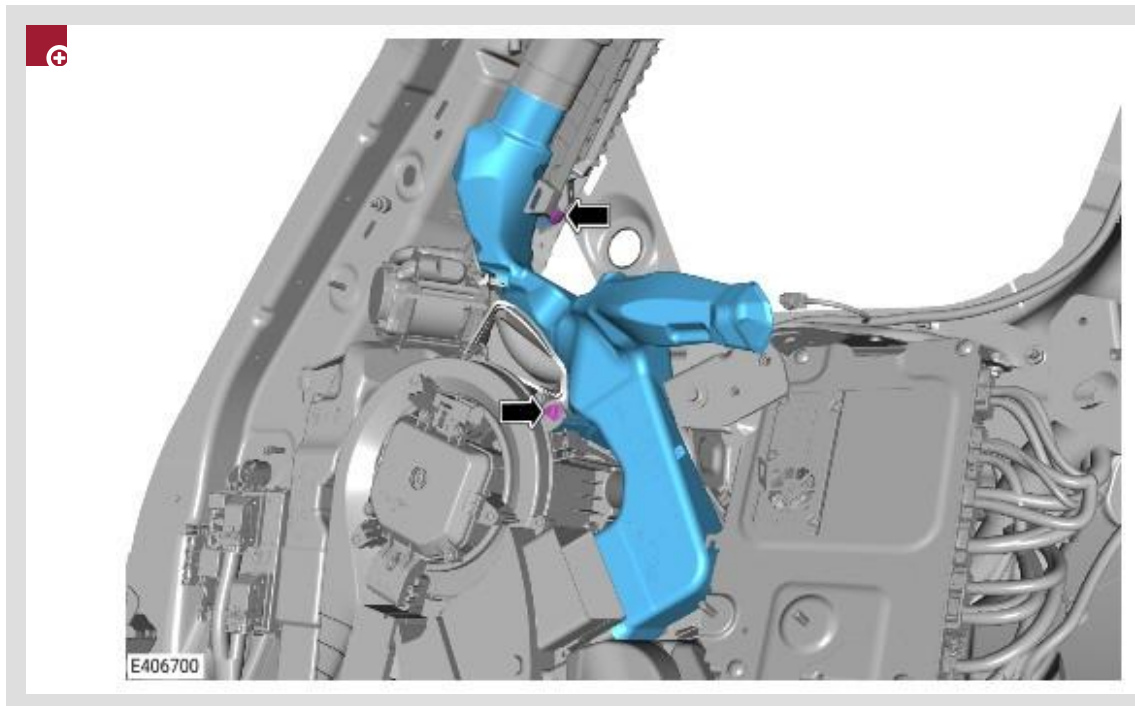

Remove the air duct.

- Remove the screw.
- Remove the clip.

Range Rover 7 Seat Vehicles With Hot Market Specification Air Ducts

37.

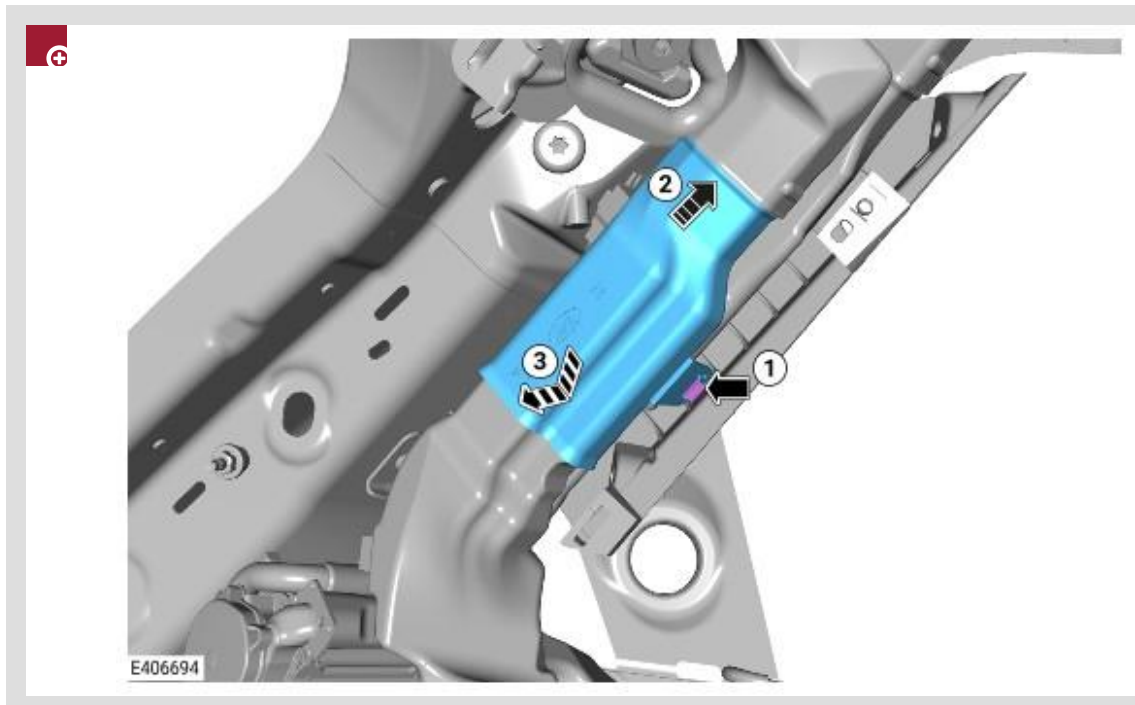

Remove the air duct in the sequence shown in the illustration..

38.

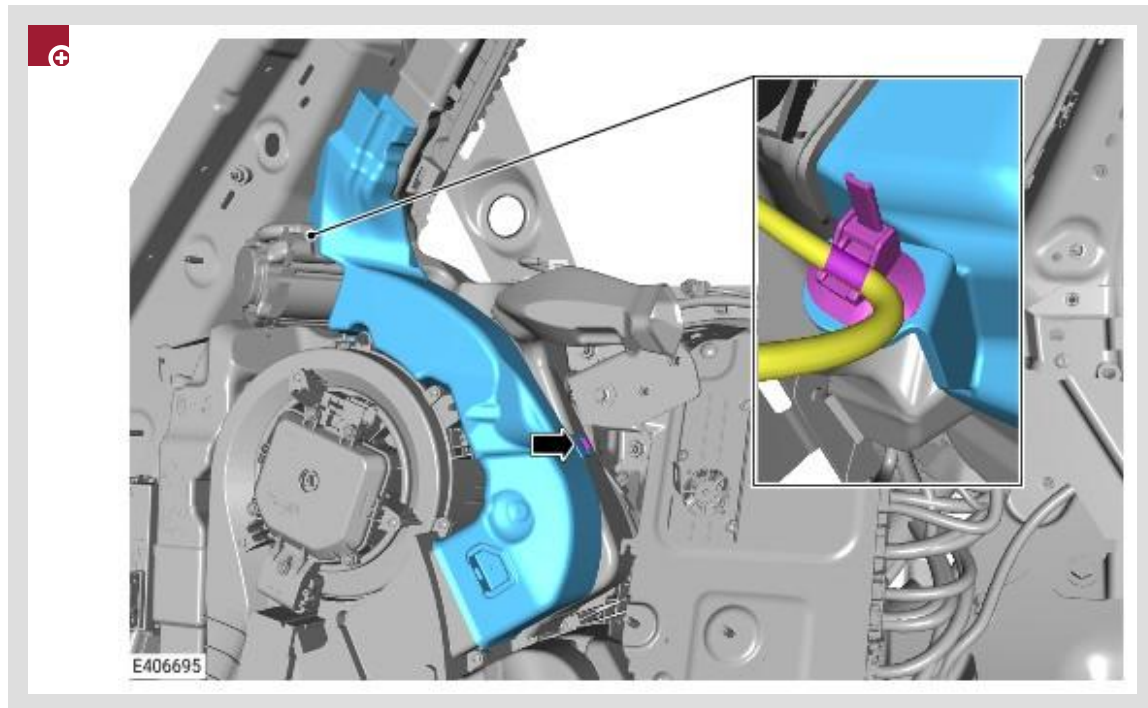

Remove the air duct.

- Release the clip.
- Release the wiring harness clip.

39.

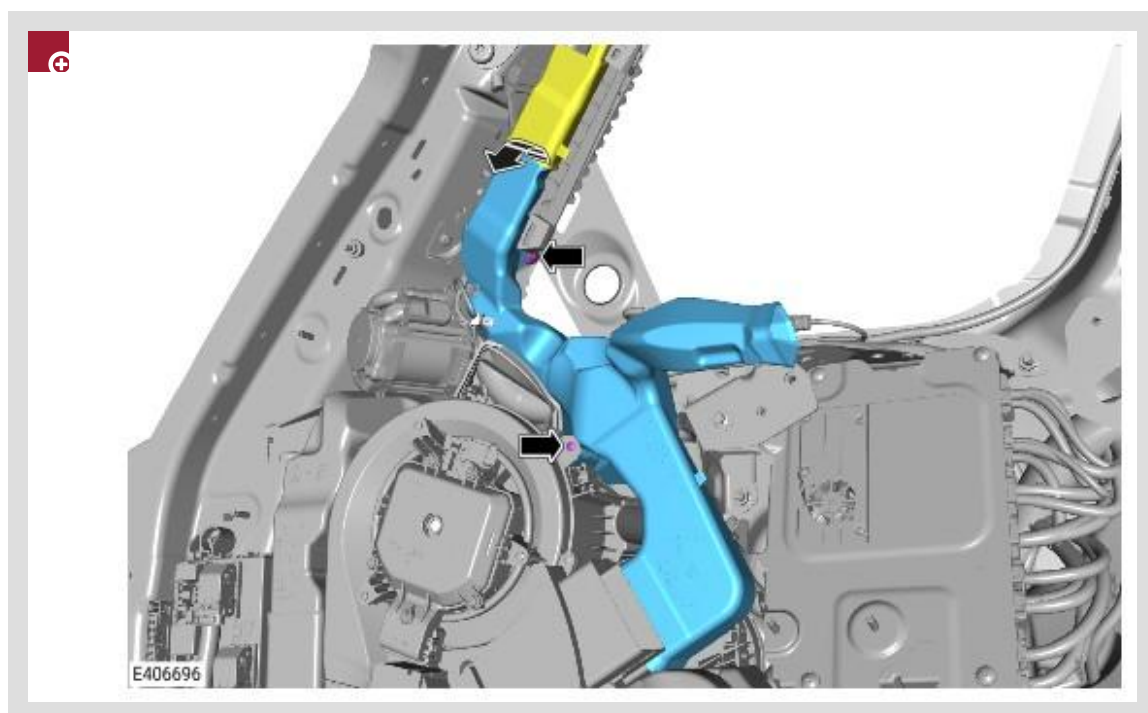

Remove the air duct.

- Remove the clip.
- Remove the fir tree clip.

All Range Rover 7 Seat Vehicles

40.

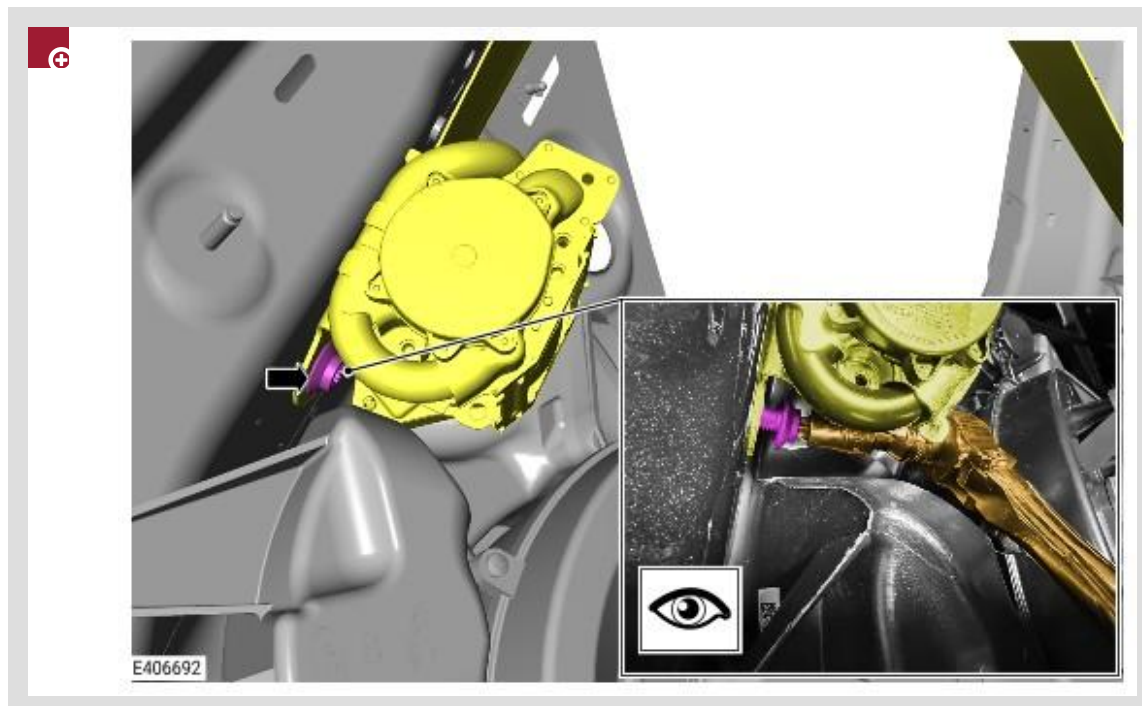

Reposition the left third row seatbelt retractor for access.

- Remove the bolt.
 - Torque: **40Nm**

41.

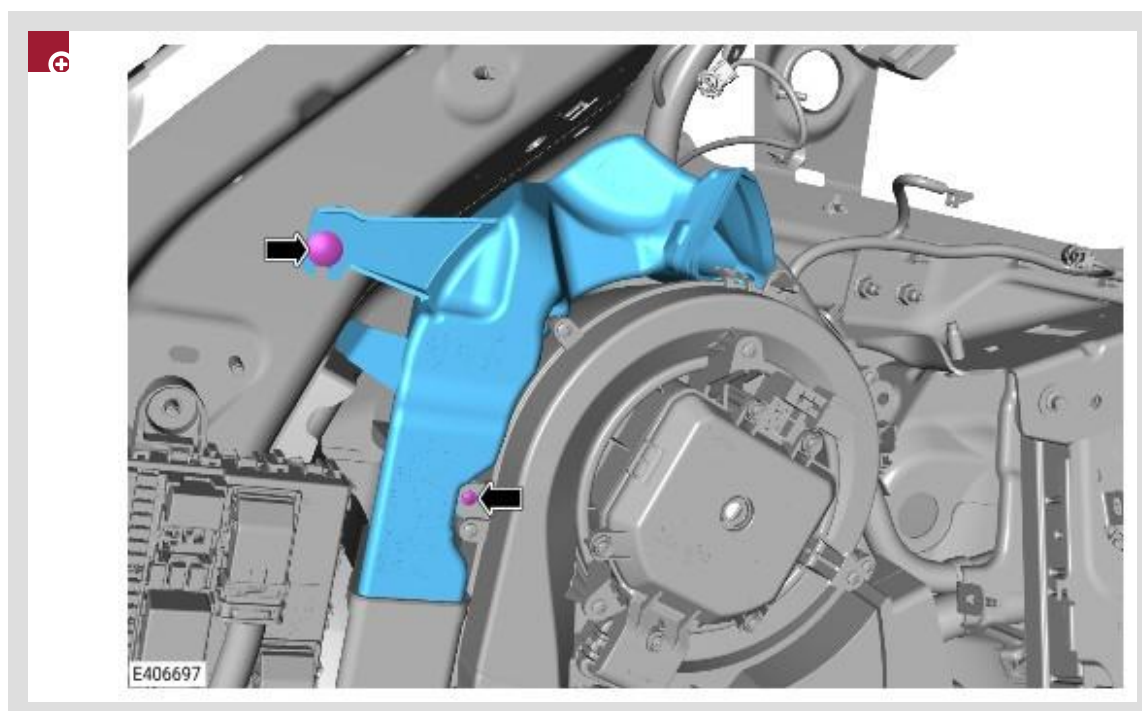

Remove the air duct.

- Remove the scrivet.
- Remove the fir tree clip.

42.

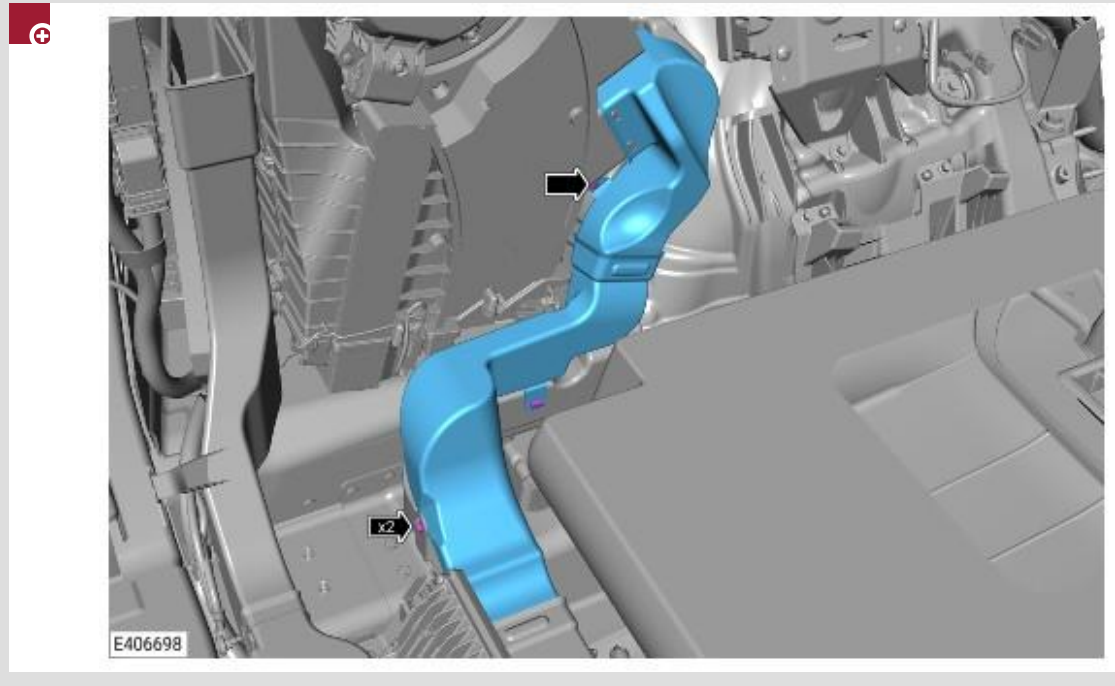

Remove the air duct.

- Remove the scrivet.
- Release the 2 clips.

43.

⚠ CAUTION:

Only raise the auxiliary climate control assembly high enough to access the drain grommet (approximately 25 mm). Failure to follow this instruction may lead to damage to the component.

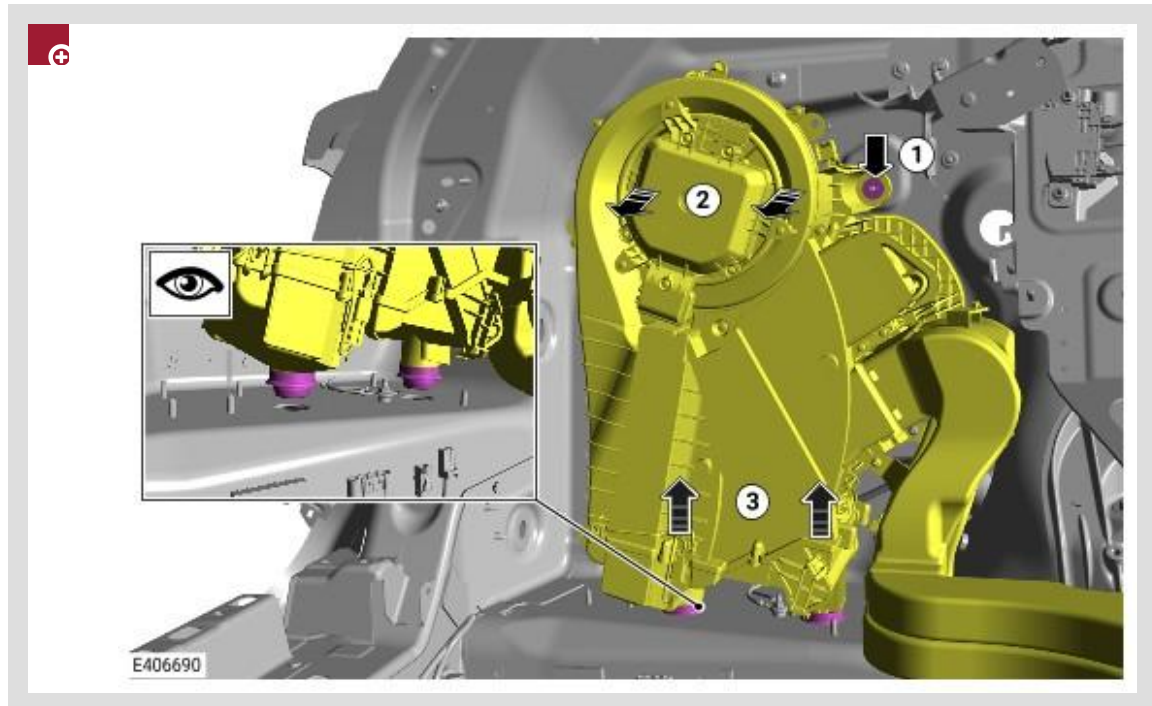

Raise the auxiliary climate control assembly to allow access to the drain grommet.

1. Remove the nut.
 - Torque: **5Nm**
2. Pull the top of the auxiliary climate control assembly forward to release it from the stud.
3. Raise the auxiliary climate control assembly.

44.

NOTE:

Only remove the drain grommet shown in the illustration. The grommet further forward on the auxiliary climate control assembly is for location purposes only.

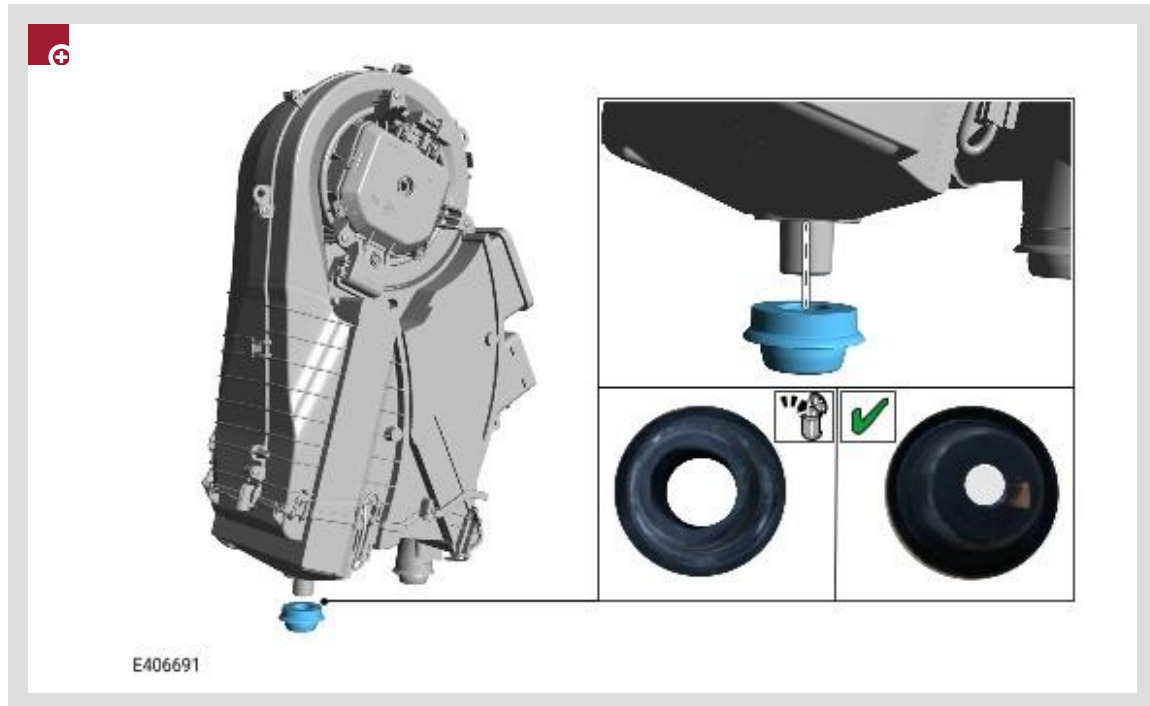

Renew the drain grommet shown in the illustration.

- Remove and discard the drain grommet.
- Install the new reduced inner diameter drain grommet, shown with the **GREEN ✓** in the illustration.

45. Reverse steps 19 - 43.

Range Rover 5 Seat / Executive Seat Vehicles Only

46. Open the left rear door.

47.



Open the upper tailgate.

48.



Open the lower tailgate.

49.

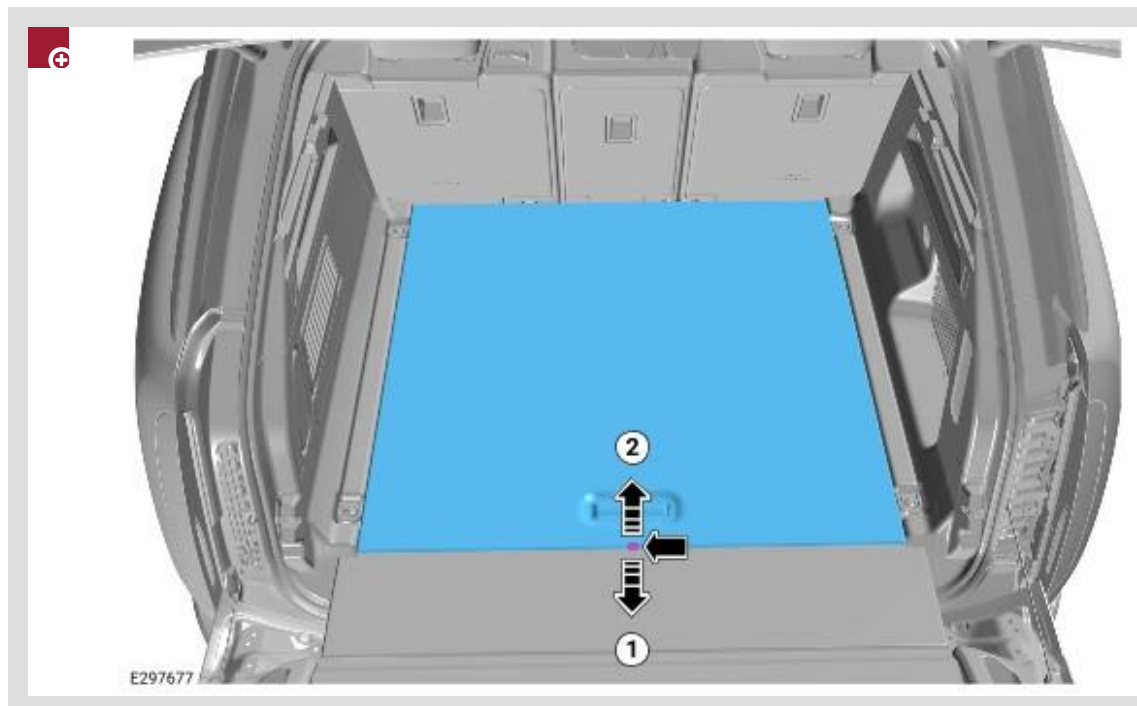

Remove the loadspace floor panel in the sequence shown in the illustration.

50.

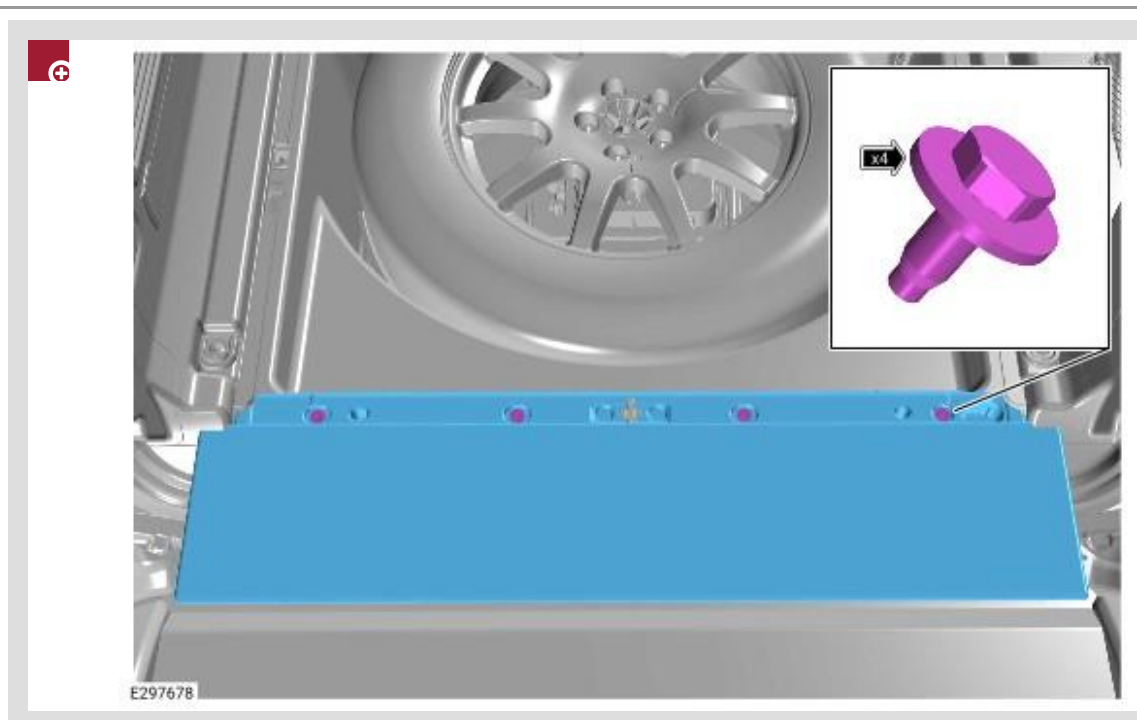

Remove the active load space cover.

- Remove the 4 bolts.
 - Torque: **7Nm**

51.

 **NOTE:**

If equipped.

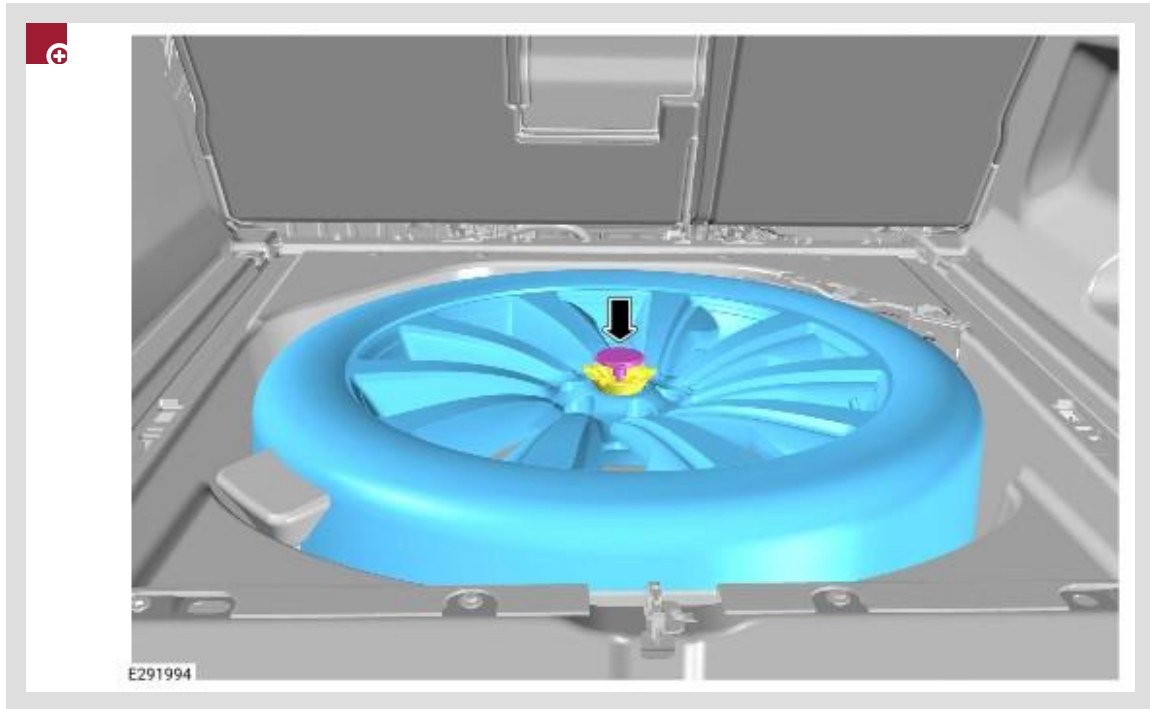

Remove the spare wheel.

52.

NOTE:

Range Rover vehicles installed with smart loadspace compartment floor only.

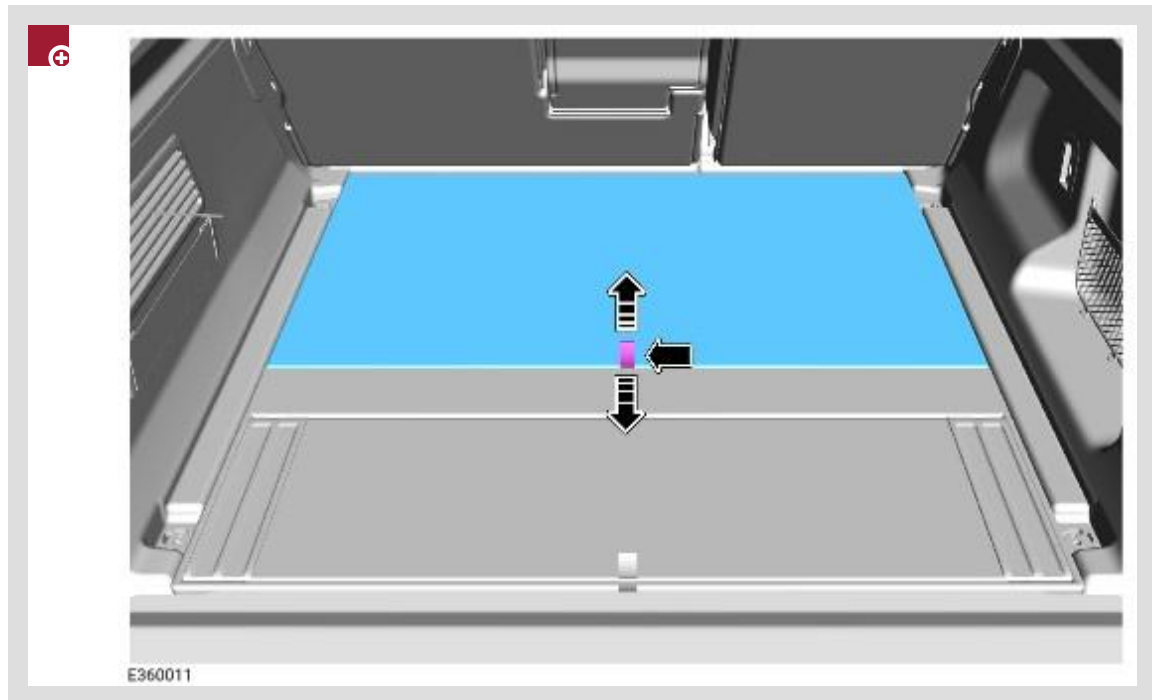

Remove the loadspace compartment floor trim panel.

- Release the latch.

53.

NOTE:

Range Rover vehicles installed with smart loadspace compartment floor only.

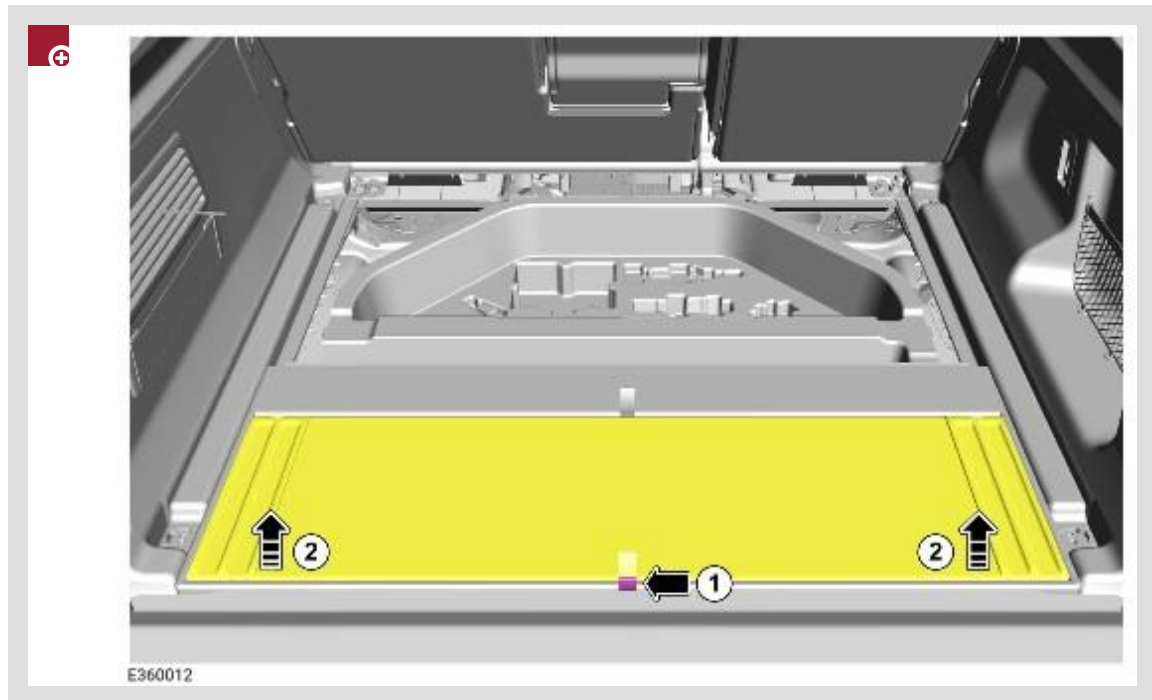

Release and raise the smart loadspace compartment floor in the sequence shown in the illustration.

54.

NOTE:

Range Rover vehicles installed with smart loadspace compartment floor only.

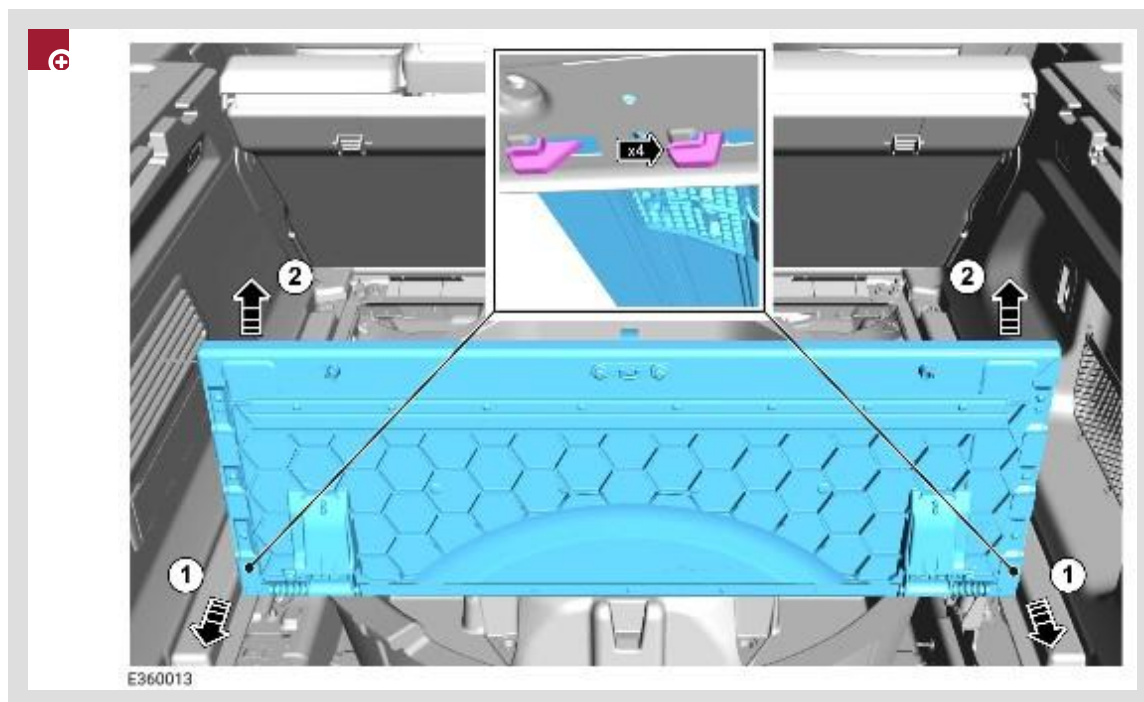

Remove the smart loadspace compartment floor in the sequence shown in the illustration.

55.

 **NOTE:**

If equipped.

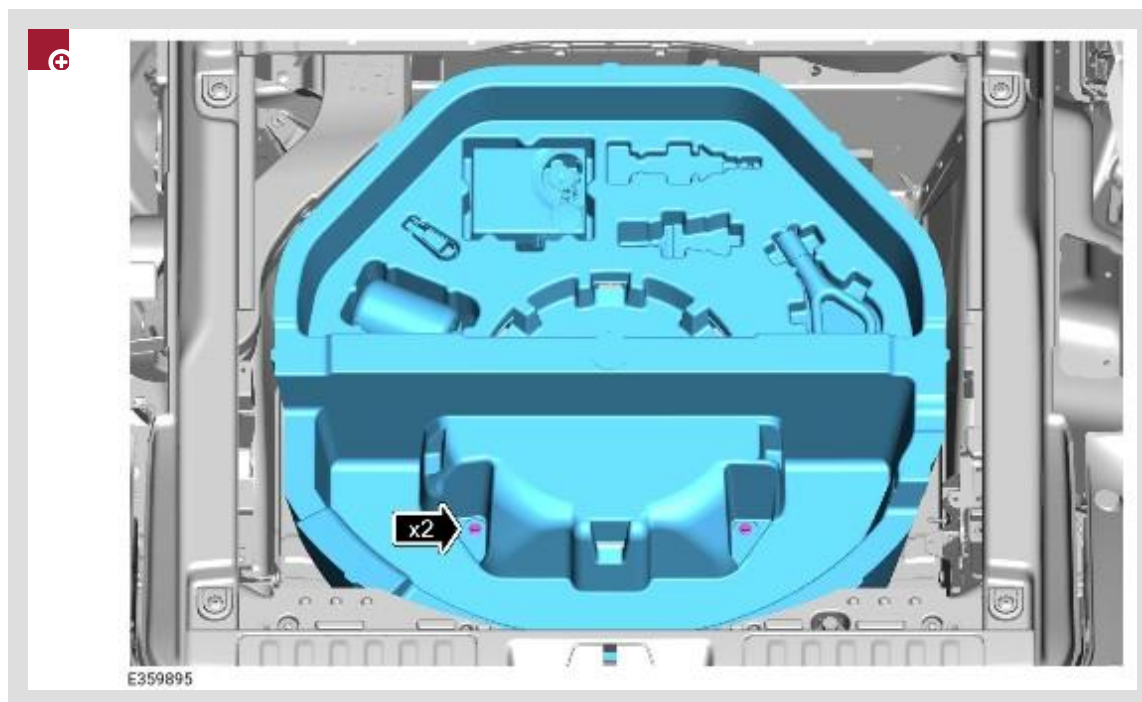

Remove the foam tray.

- Remove the 2 bolts.
 - Torque: **27.5 Nm**

56.

Remove the left Loadspace Trim Panel (see TOPIx Workshop Manual section 501-05: Interior Trim and Ornamentation - Loadspace Trim Panel - Vehicles With: Executive Seats / 5 Seats).

57.

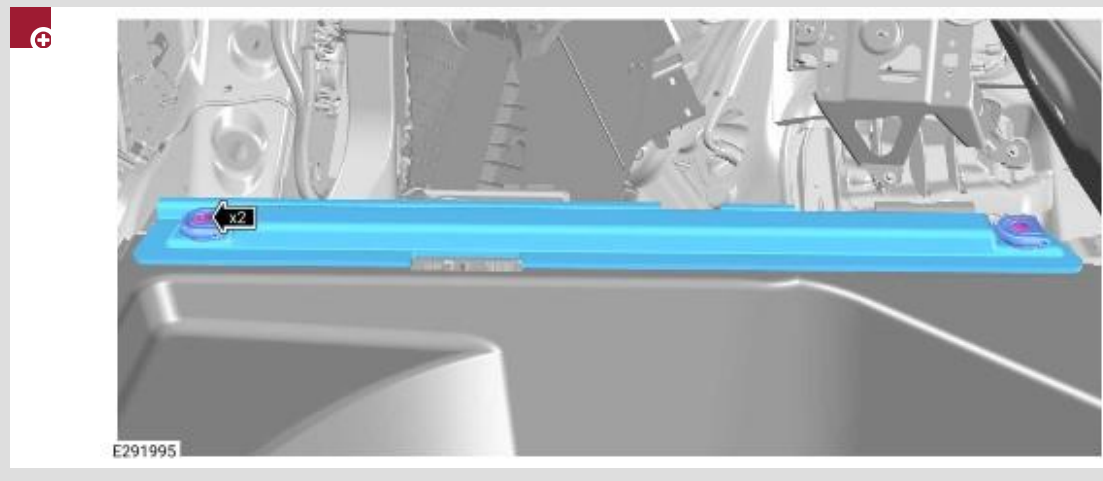

Remove the left loadspace side rail.

- Remove the 2 bolts.
 - Torque: **20Nm**
- Remove the 2 D-loop anchor points.

58.



Remove the C-pillar lower trim panel.

- Remove the bolt.
 - Torque: **5Nm**
- Release the 5 clips.

59.

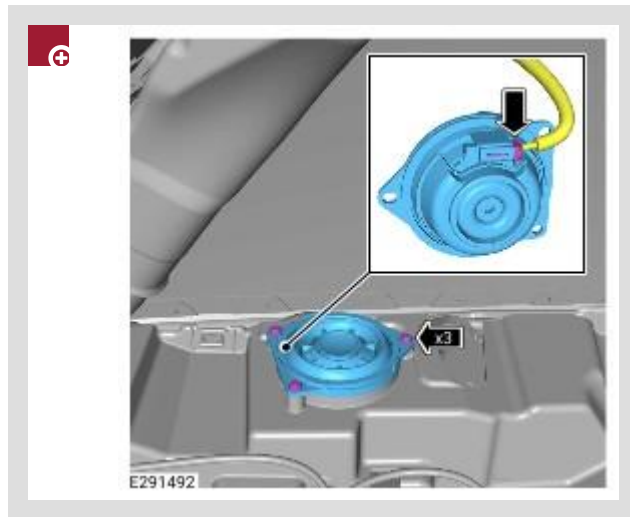

Remove the loadspace speaker.

- Remove the 3 screws.
- Disconnect the electrical connector.

60.

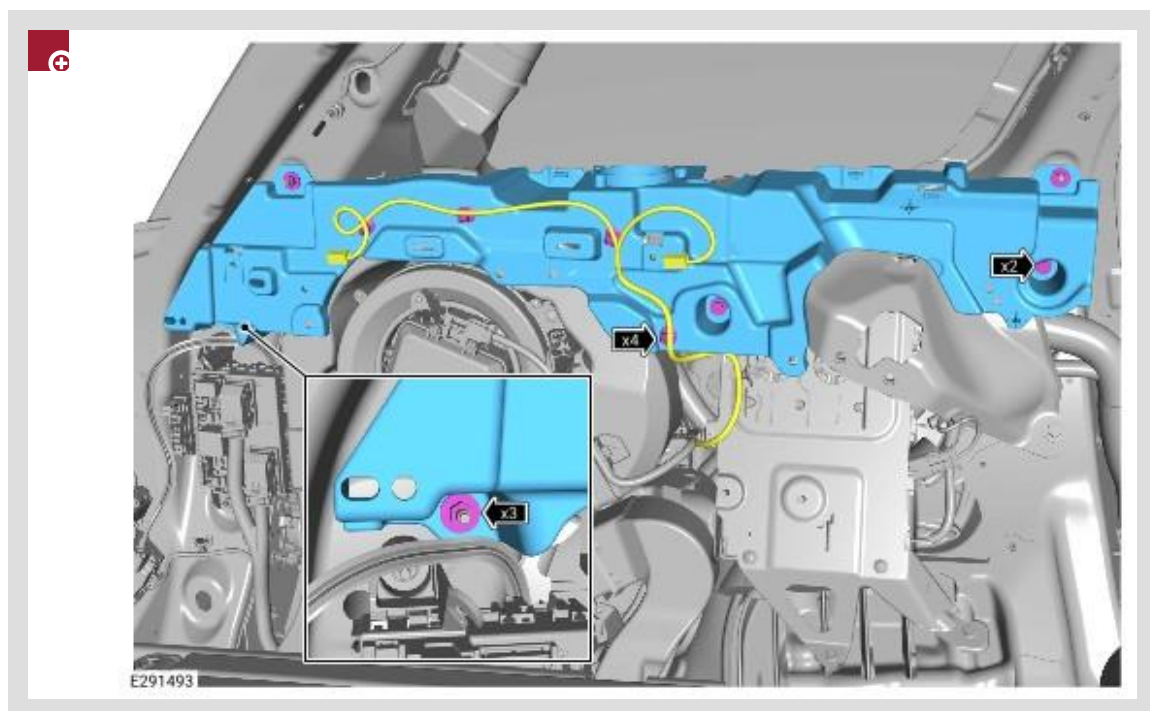

Remove the left upper loadspace bracket.

- Release the 4 wiring harness clips.
- Remove the 2 bolts and the 3 nuts.
 - Torque: **5Nm**

61.

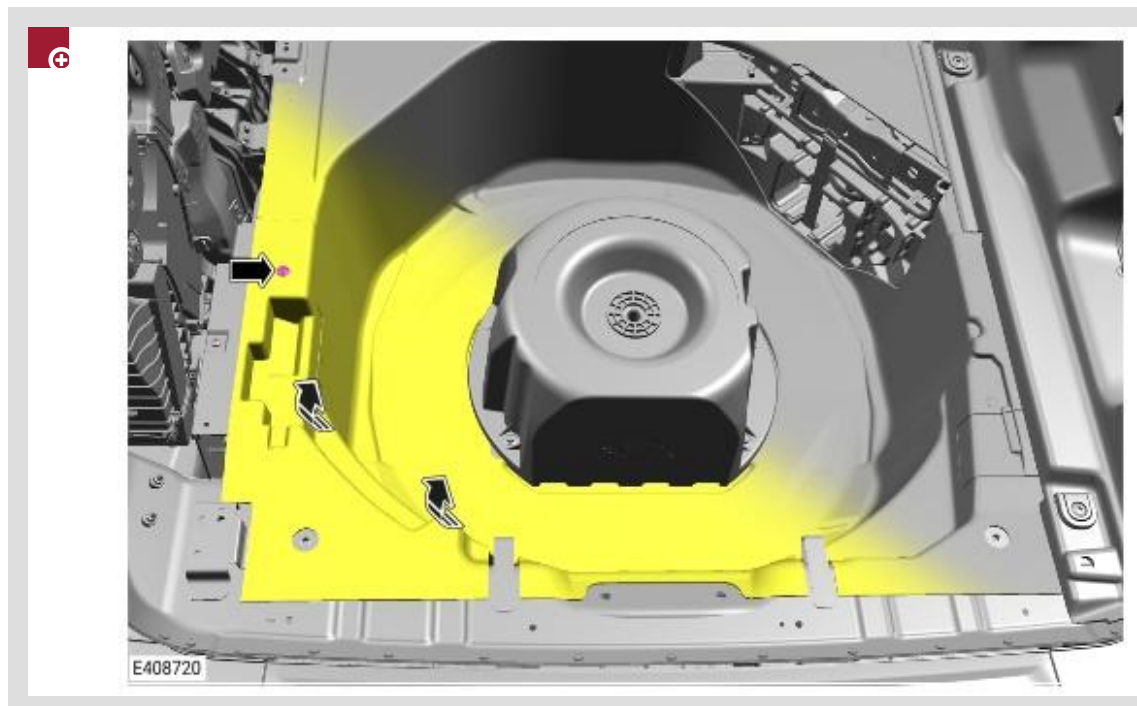

Reposition the loadspace floor carpet for access.

- Remove the fir tree clip.

62.



Reposition the NFSM assembly.

- Remove the 2 nuts.
 - Torque: **5.4Nm**
- Remove the nut.
 - Torque: **48Nm**

63.

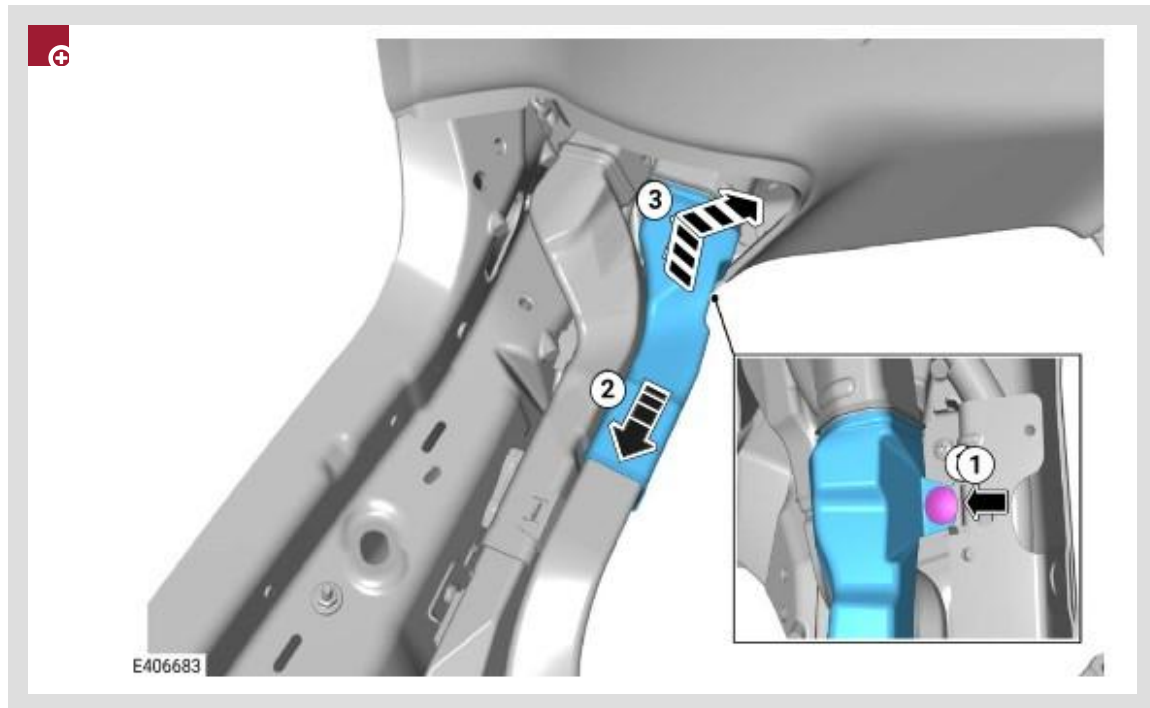

Remove the air duct in the sequence shown in the illustration.

64.

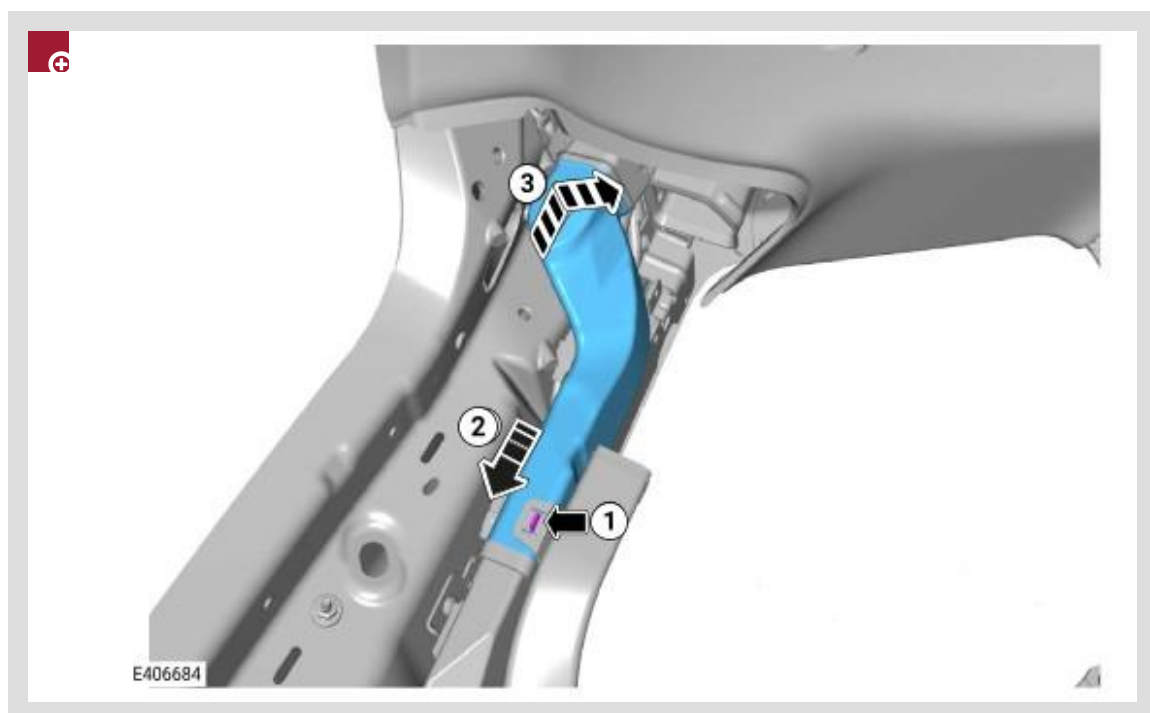

Remove the air duct in the sequence shown in the illustration.

65.

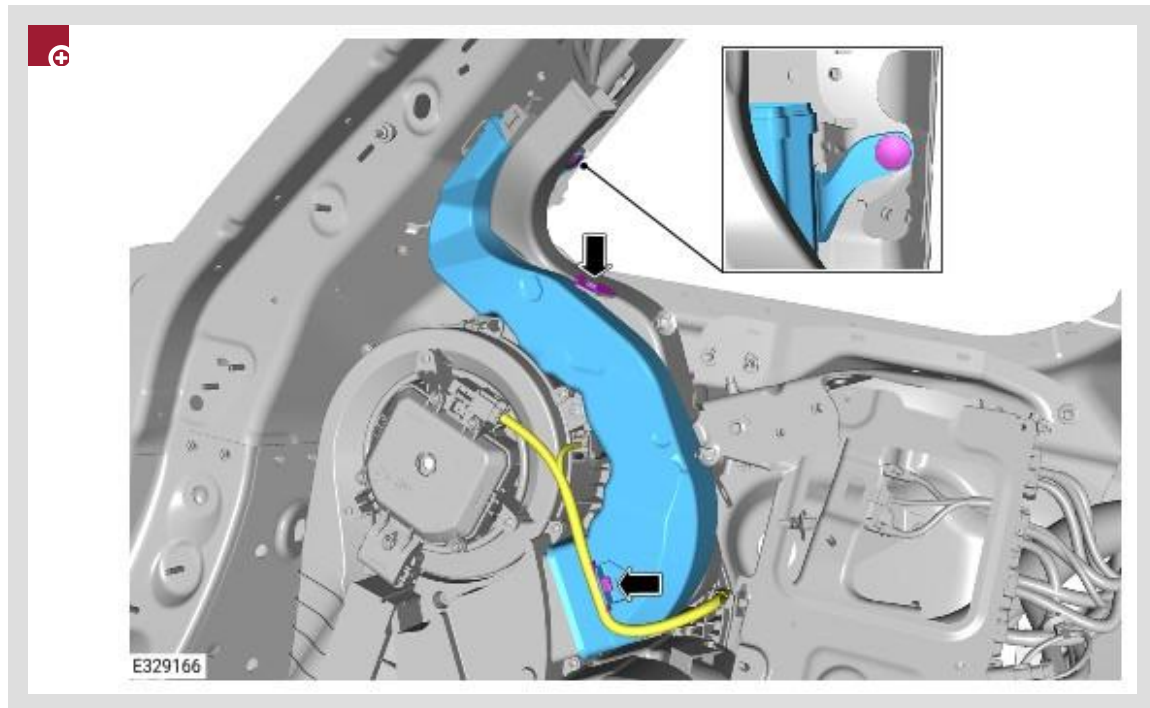

Remove the air duct.

- Remove the clip.
- Release the securing tab.

66.

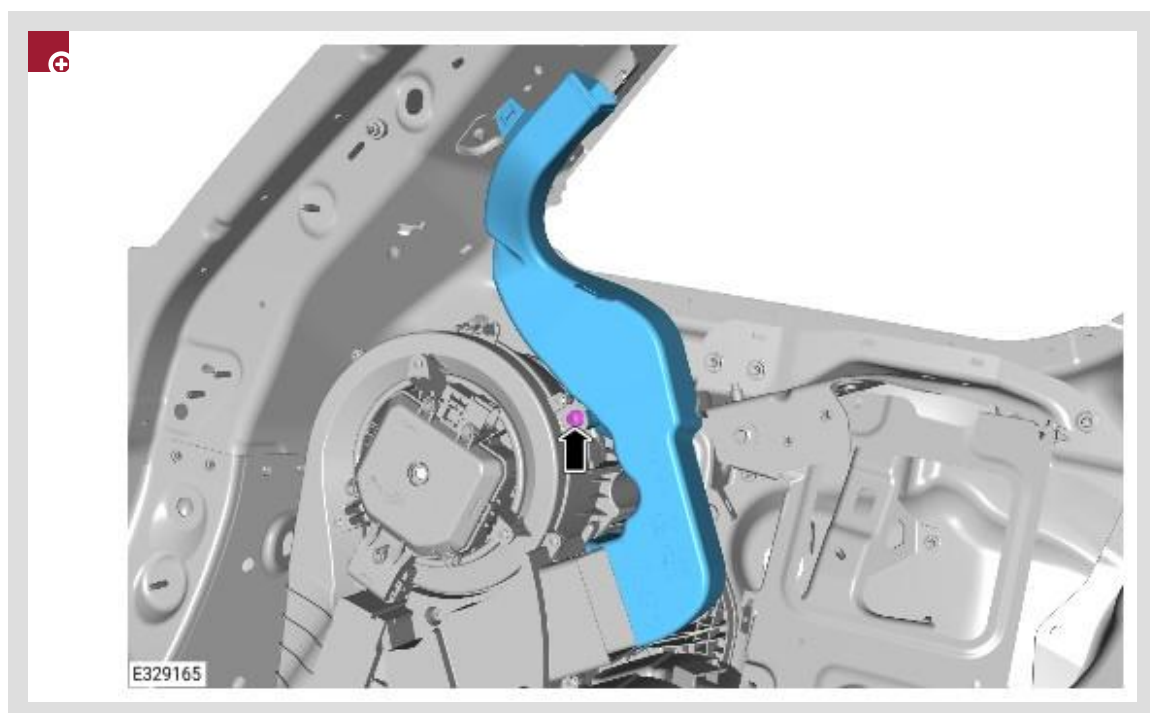

Remove the air duct.

- Remove the clip.

67.

⚠ CAUTION:

Only raise the auxiliary climate control assembly high enough to access the drain grommet (approximately 25 mm). Failure to follow this instruction may lead to damage to the component.

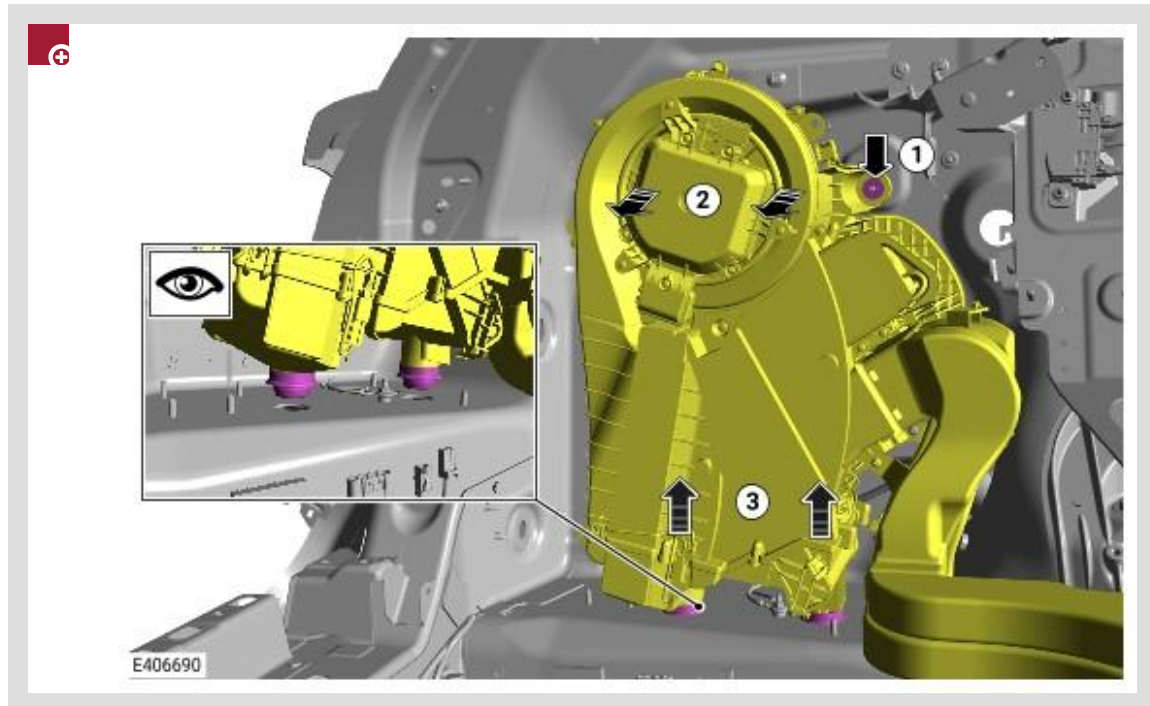

Raise the auxiliary climate control assembly to allow access to the drain grommet.

1. Remove the nut.
 - Torque: **5Nm**
2. Pull the top of the auxiliary climate control assembly forward to release it from the stud.
3. Raise the auxiliary climate control assembly.

68.

NOTE:

Only remove the drain grommet shown in the illustration. The grommet further forward on the auxiliary climate control assembly is for location purposes only.

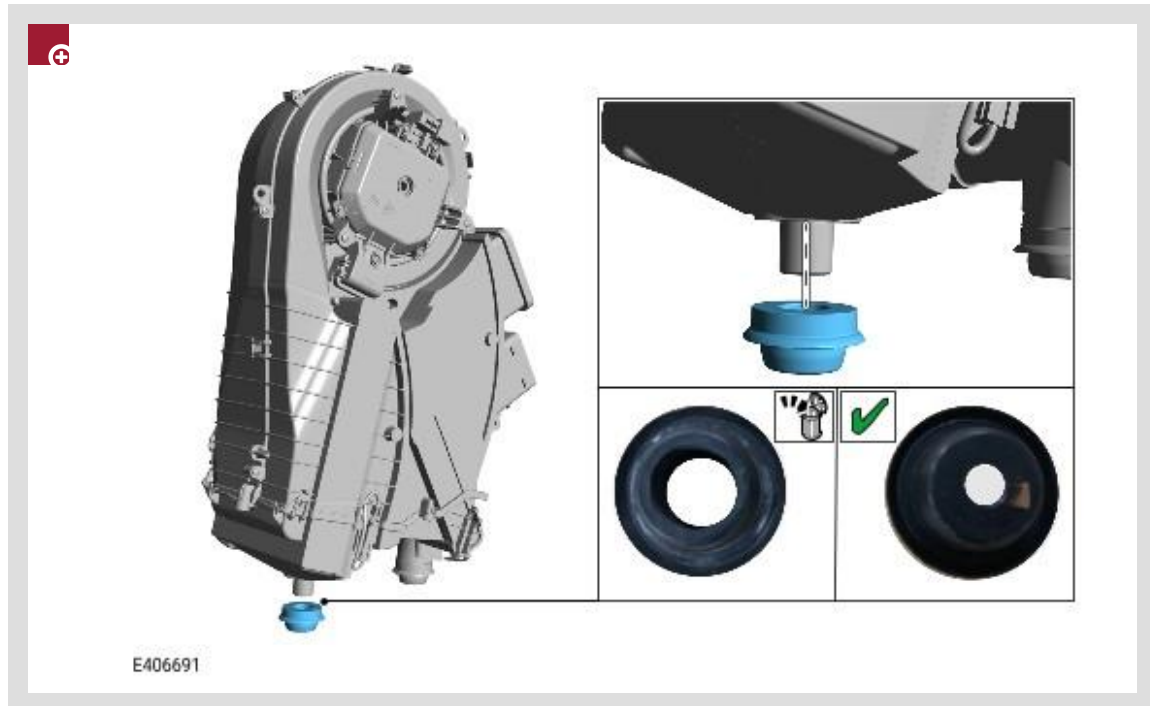

Renew the drain grommet shown in the illustration.

- Remove and discard the drain grommet.
- Install the new reduced inner diameter drain grommet, shown with the **GREEN ✓** in the illustration.

69.

Reverse steps 46 - 67.