



FIELD SERVICE CAMPAIGN – 26103

01 June 2026

SUBJECT:

Air Conditioning (A/C) Refrigerant Oil Service Label Replacement

MODELS INVOLVED:

International® eMV™ Series Trucks

DEFECT DESCRIPTION:

This document will guide the user through replacing the A/C Refrigerant Oil Service Label.

ELIGIBILITY:

This procedure applies ONLY to vehicles marked in the International® Service PortalSM with FSC 26103. Also complete any other open campaigns listed on the Service Portal at this time.

PARTS REQUIRED:

Part Number	Description	Quantity
4757118C1	Product Graphic, Refrigerant Charge, MV	1

Table 1 Parts Information

WORK INSTRUCTIONS

GOVERNMENT REGULATION: Engine fluid (oil, fuel, and coolant) may be a hazard to human health and the environment. Handle all fluid and other contaminated materials (such as filters and rags) in accordance with applicable regulations. Recycle or dispose of engine fluids, filters, and other contaminated materials according to applicable regulations.

WARNING! To prevent personal injury and / or death, or damage to property, park vehicle on hard flat surface, turn the engine off, set the parking brake, and install wheel chocks to prevent the vehicle from moving in both directions.

WARNING! To prevent personal injury and / or death, always wear safe eye protection when performing vehicle maintenance.

WARNING! To prevent personal injury and / or death, or damage to property, keep flames or sparks away from vehicle and do not smoke while servicing the vehicle's batteries. Batteries expel explosive gases.

WARNING! To prevent personal injury and / or death, or damage to property, remove the ground cable from the negative terminal of the battery before disconnecting any electrical components. Always connect the ground cable last.

WARNING! To prevent personal injury and / or death, wear and use approved high-voltage Personal Protective Equipment (PPE) when near a high-voltage electric vehicle. Inspect PPE before use. Do not use gloves or other PPE with expired dates, holes, cracks or damage. NEVER touch energized ORANGE high-voltage cables or high-voltage components without wearing approved high-voltage PPE.

WARNING! To prevent personal injury and / or death, or damage to property, read all information in the Safety Information and High-Voltage Safety sections of the service manual.

1. Park vehicle on flat, level surface.
2. Put drive mode selector in Park or Neutral and set the parking brake.
3. Turn ignition to Key OFF position.
4. Install wheel chocks.

5. Unlatch and open hood.

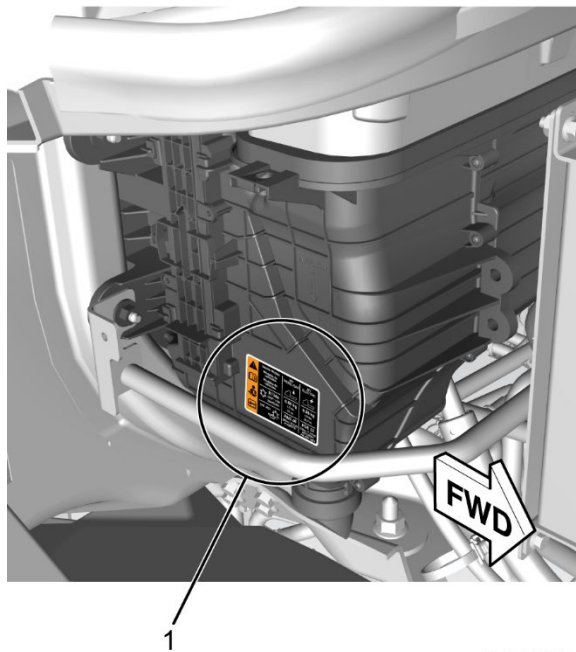

0000494617

Figure 1. A/C Refrigerant Service Label Location

1. A/C refrigerant service label

6. Locate the A/C refrigerant service label (Figure 1, Item 1) on the right-side of the vehicle on the air filter housing assembly.

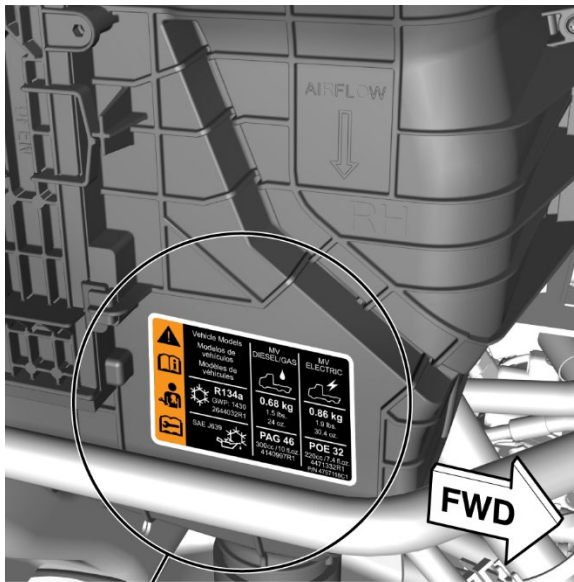

0000494618

Figure 2. Location of Incorrect A/C Refrigerant Service Label

1. Label location

7. Remove the incorrect label from the label location (Figure 2, Item 1).
8. Wipe and clean the area.

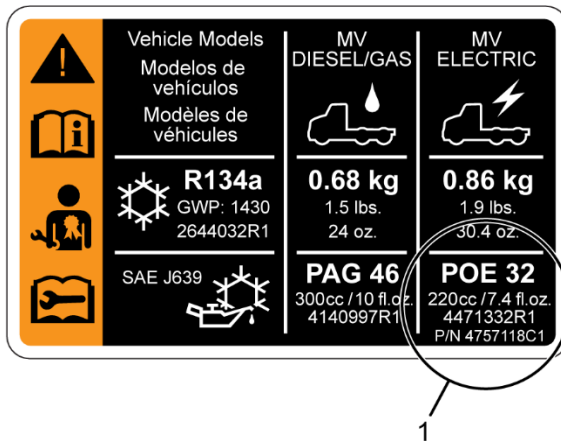

0000494619

Figure 3. A/C Refrigerant Oil Service Label

1. Part number and accurate amount in fluid ounces

9. Ensure the label shows the correct information, especially the part number and accurate amount in fluid ounces (fl. oz.) (Figure 3, Item 1).

10. Install the new A/C refrigerant oil service label in the same location as the old label.
11. Close and latch hood.
12. Remove wheel chocks.
13. Return vehicle to service.

LABOR INFORMATION

Operation number must appear on all claims.

Operation Number	Description	Time
A40-26103-1	Remove and Replace A/C Refrigerant Label	0.2 hrs

Table 2 Labor Information

WARRANTY CLAIMS

Warranty claim expense is to be charged to Warranty. Claims are to be submitted in the normal manner, making reference to Field Service Campaign 26103.

Section 7 of the Warranty Policy and Procedures Manual contains further information related to the submission and processing of AFC / Recall claims.

As with all claim submissions, items acquired locally must be submitted in the “Other Charges” tab. The cost of any bulk items (such as a bag of cable tie straps, roll of wire, barrel of oil, or tube of silicone) should be prorated for the cost of the individual pieces / amount used during each repair.

To make sure this important improvement is made in a timely manner, all claims for 26103 activity must be submitted by 01 06 2027 or within the normal warranty period for the component repaired, if after 01 06 2027.

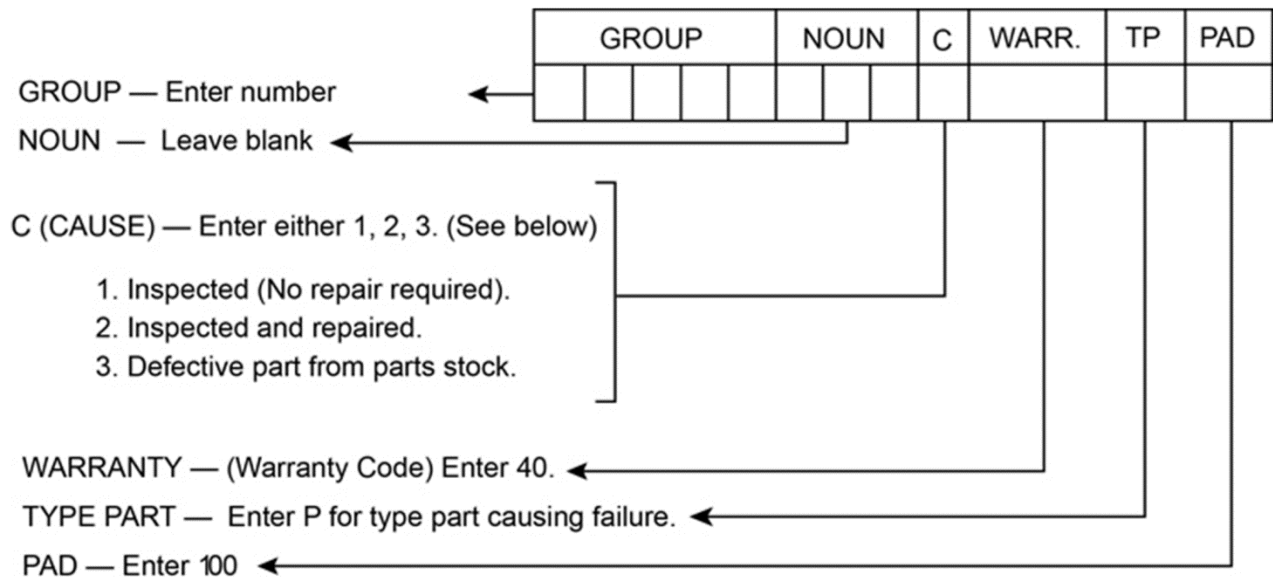

0000047910

International Motors, LLC*

***International Motors, LLC d/b/a**

International Motors USA LLC in Illinois and Ohio.