

**Updates to the Grabber Carriage Motors
including carriage motor bolts on the
Zero Radius**

Date: May 06, 2026
Bulletin Name: ZR-IB-012-E
Model: Zero Radius Model 48
Model Years: 2009 - Present

Purpose:

This bulletin instructs how to replace the Zero Radius™ (ZR) grabber carriage motor bolts with new bolts if the existing motor bolts are loosening.

Revision E replaces two parts with updated parts.

Notice:

- This bulletin should be read and understood in its entirety before performing this update procedure.
- All procedures outlined in the bulletin must be performed by skilled service personnel. Refer to the product service manual for descriptions of maintenance procedures.

SAFETY NOTICE

Perform your company's Lockout/Tagout procedure. If your company does not have a Lockout/Tagout procedure, follow OSHA 1910.147 and 1910.146 Confined Space as appropriate.

SAFETY NOTICE

Use appropriate Personal Protective Equipment (PPE) as required by your company.

Equipment Required:

Customer to supply:

- Brake cleaner
- Electric drill and assorted drill bits
- 3/8"-16 tapered tap
- 3/8"-16 bottoming tap
- 3/8" tube brush
- Bristle brush
- Air compressor
- Rotary sander
- Rubber mallet
- Overhead crane or lifting device and chains
- Hydraulic fitting caps/plugs
- 9/16" ratchet side wrench
- 9/16" wrenches and socket wrench
- Torque wrench
- Gloves (such as industrial nitrile gloves)
- Rolling head pry bar
- EP No. 2 lithium grease
- Wire brush

Parts Required:

Purchase from your McNeilus refuse service network or visiting www.streetsmartparts.com.

<i>Kit Part Number: 1710808</i>			
Item	Part Number	Description	Qty.
1	1136593	SCR,CAP,HEX .38-16X1.25 G8 ZY	8
2	1710079	WASH,FLT .38X.81X.12 ZY HDN	24
3	1427860	SCR, CAP, SOC .38-16 X 1.50 574 ZC	16
4	1666915	Loctite® 263 (or equivalent)* (0.5ml)	1
5	1666916	Loctite® 515 (or equivalent)* (50ml)	1
6	1666917	Loctite® 680 (or equivalent)* (0.5ml)	1

* Follow package instructions for application

Procedure 1: Remove the Grabber Assembly from the Mast

1. Perform your company's Lockout/Tagout procedure. If your company does not have a Lockout/Tagout procedure, follow OSHA 1910.147 and 1910.146 Confined Space as appropriate.
2. Remove the grabber faceplate. Retain it and its hardware for reinstallation (Figure 1).

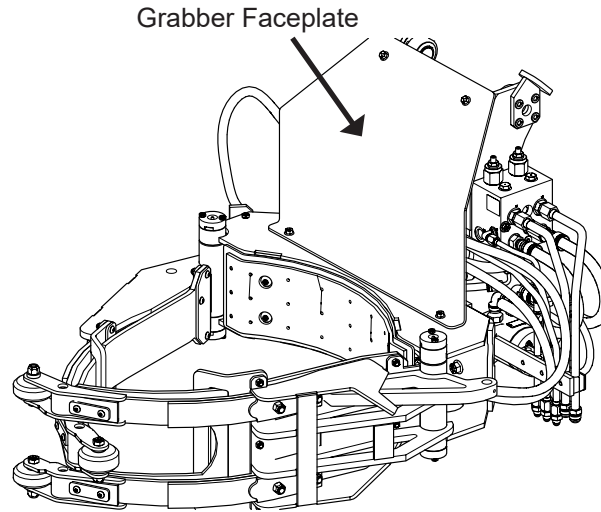

Figure 1

3. Attach chains and a crane to the grabber carriage assembly to support the assembly when it is removed from the mast.
4. Remove and retain grease zerks from the rollers.
5. Remove and retain all four grabber roller sets that hold the grabber carriage assembly to the mast — Figure 2 shows one of the top sets and Figure 3 shows the bottom sets. A set consists of a roller, bracket, and bolts (and proximity switch flag bracket if installed).
6. Inspect the rollers for wear and replace if necessary by calling 888-686-7278 to order parts. If a roller needs to be replaced, it is recommended to replace all rollers at the same time.

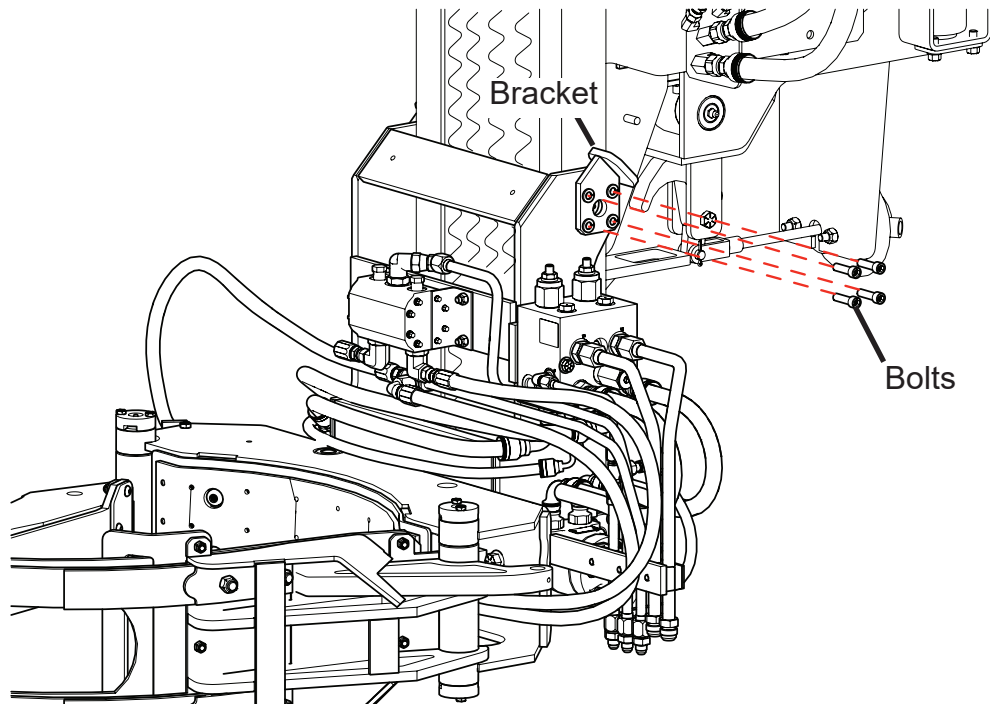

Figure 2

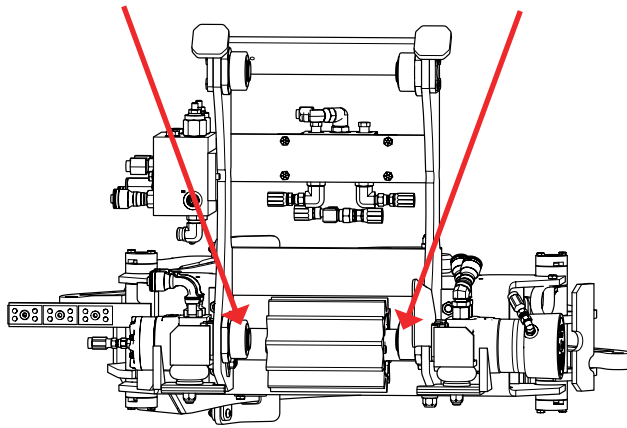

Figure 3

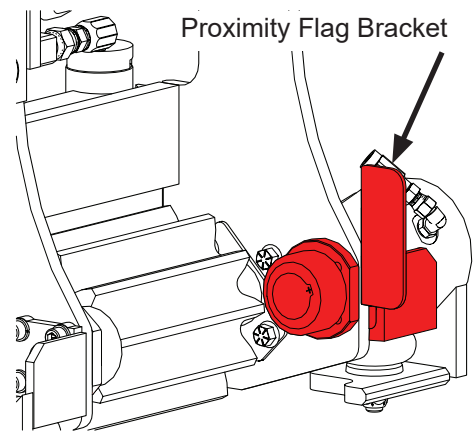

Figure 3 Close-up

7. Remove the hydraulic lines and plug fittings with caps. Retain all hydraulic lines and hardware as well as a record of the hydraulic line routing.
8. Remove the grabber carriage assembly from the mast and place the assembly on the ground or a work bench. Keep the chains/crane attached to the assembly for safety.
9. Remove and inspect the double check valve from the Over Center Manifold Valve for contaminants (location shown on Figure 4).
 - If contaminants are found or the double check valve is broken, stop working on this bulletin. The entire Over Center Manifold Valve block must be replaced before continuing with this bulletin. Contact McNeilus at 888-686-7278 or visit www.streetsmartparts.com to order a new Over Center Manifold Valve Block. Call a McNeilus National Service Representative at 888-686-7278 for installation information.
 - If contaminants are not found, replace the double check valve and continue with this bulletin.

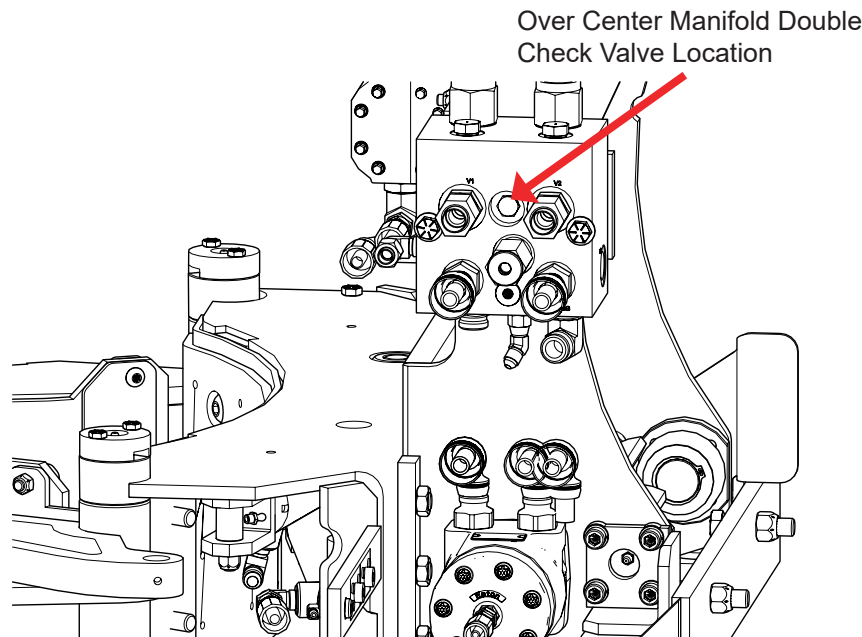

Figure 4

NOTE: The next steps detail work conducted on the backside of the grabber carriage assembly (see Figure 5).

10. If there are locking tabs that hold the bolts connecting the motors to the grabber carriage assembly, remove and discard the tabs from both motors.
11. Remove the motors, grabber gear, and all related hardware (Figure 5). Retain these items until further notice in this bulletin.
12. Inspect the motors, grabber gear, thrust washers (found near motor spline), motorshaft support bearing, and 4-hole bearing retainer plate for damage. If damage is found, stop working on this bulletin and order a new part by calling 888-686-7278 or visiting www.streetsmartparts.com. Continue with this bulletin once you have the new part.

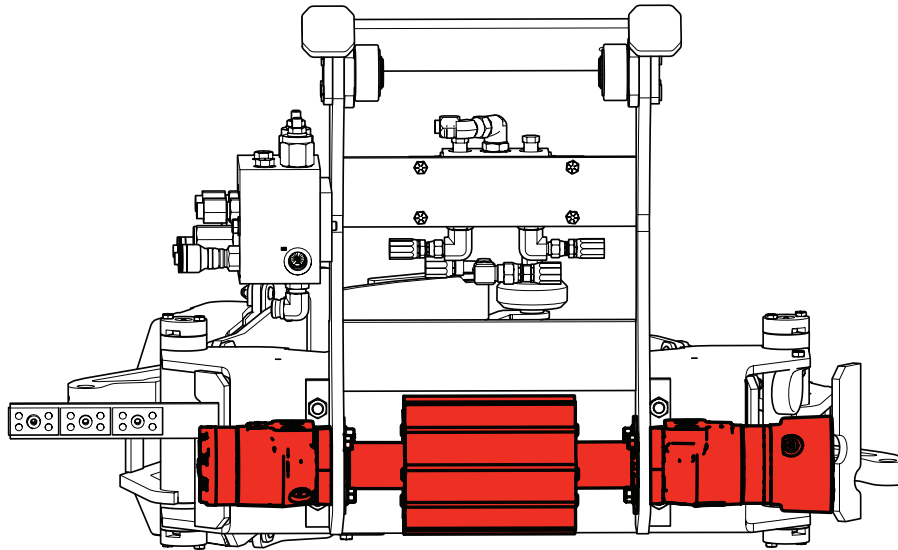

Figure 5

Procedure 2: Cleaning Procedures

2.1 Cleaning the Grabber Carriage Assembly

1. Residual Loctite® must be removed from specific bolt holes. On each side of the grabber carriage assembly, at the location where the motors attach to the grabber assembly, clean the four (4) bolt holes and the large hole for the motor shaft.
 - a. Start by cleaning inside the bolt holes with a tube brush on an electric drill (see Figure 6 for location of holes). Clean the bolt holes on **both sides of the grabber assembly** where the motors are bolted onto the grabber assembly. The residue from the Loctite® is hard and is a contaminate for the installation of the new hardware if it is left in place. The holes are clean when all the Loctite® is removed; do not grind the holes.
 - b. Clean the large hole for the motor shaft (see Figure 6) with a tube brush on an electric drill. Clean both of the large holes on **both sides of the grabber assembly**. The holes are clean when all the Loctite® is removed; do not grind the holes.
 - c. Use a rotary sander on the outside and inside of the cleaned area to remove rust, paint, or other contaminates.

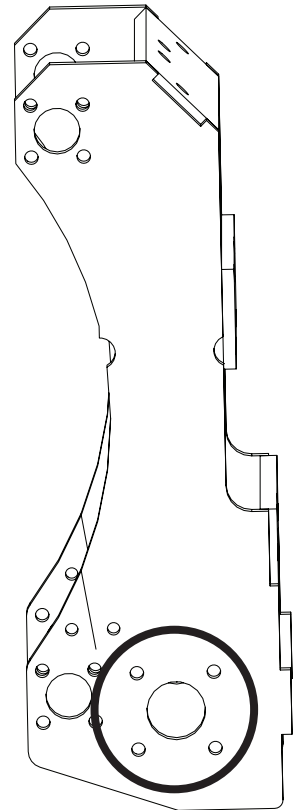

Figure 6

2.2 Cleaning the Motors and Grabber Rollers

1. Set the motors upright with the mounting holes facing upright (Figure 7).
2. Use a clean 3/8"-16 tapered tap and an electric drill to run the tap into each mounting hole and back out to clean the holes of contaminates.
3. Use a clean 3/8"-16 finishing tap and electric drill to run the tap into each mounting hole and back out to clean the holes of contaminates.
4. Repeat Steps 2 and 3 on the other motor.



Figure 7

5. Wear gloves for the next cleaning steps. Spray the brake cleaner in the mounting holes and on top of the flange of both motors. The brake cleaner removes the rust inhibitor on the motor and any remaining contaminates so Loctite® will adhere to the motor flange.
6. Use a clean 3/8" tube brush and the electric drill to clean each mounting hole. **DO NOT put the drill in reverse** — the brush will get stuck in the mounting hole. **Instead, pull the brush out of the mounting holes.**
7. Turn the motors on their sides to drain the brake cleaner into an appropriate containment pad or berm.
8. Spray more brake cleaner on the top of the motor flange and into the mounting holes.
9. Clean the area with the bristle brush (see Figure 8). **DO NOT** use a wire brush on the seal in the shaft.



Figure 8

10. Repeat Steps 5-9 of the Motor Cleaning Procedure until all mounting holes are clean and the area is free from rust inhibitor and oil/contaminates.
11. Use compressed air on the motors to push out any remaining contaminates from the mounting holes and to dry the flanges of the motors. The flanges should be free from oil residue and should be a dull gray color with no shine.
12. Use a rotary sander on the flat surface (mating side) of each 4-hole retainer plate to clean it.
13. Spray brake cleaner on the flat side of each 4-hole retainer plate. Then spray them with compressed air to remove contaminates and dry the retainer plates.
14. Clean the grabber roller thread holes with a clean 3/8"-16 tapered tap and an electric drill to push the tap into each mounting hole and back out and with a clean 3/8"-16 finishing tap and electric drill to push the tap into each mounting hole and back out to clean the holes of contaminates.
15. Clean the roller thread holes with a wire brush.

Procedure 3: Installation of Motors and Grabber Gear

Because of the application of Loctite®, it is important you get all of the necessary items ready for installation before beginning the procedure.

3.1 Motor Prep

1. Stand the motors upright with the mounting holes facing up.
2. Clean the bolts with the brake cleaner and air compressor.
3. Inspect the existing motorshaft support bearings for quality. If the inside race turns freely, the bearing can be reused. If not, purchase and replace with a new bearing (PN 1414603). Clean the bearing outer diameter (Figure 11) with brake cleaner and compressed air to remove contaminants.
4. Apply Loctite® 263 according to the directions on the Loctite® packaging in each bolt mounting hole on the flange side of both motors. For blind holes, apply several drops of Loctite® 263 in the lower third of the internal threads in the blind hole, or to the bottom of the blind hole.
5. Apply Loctite® 515® according to the directions on the Loctite® packaging to the top of the flange on each motor (Figure 9). **DO NOT** get Loctite in the mounting holes. **DO NOT** get Loctite on the shaft seal.

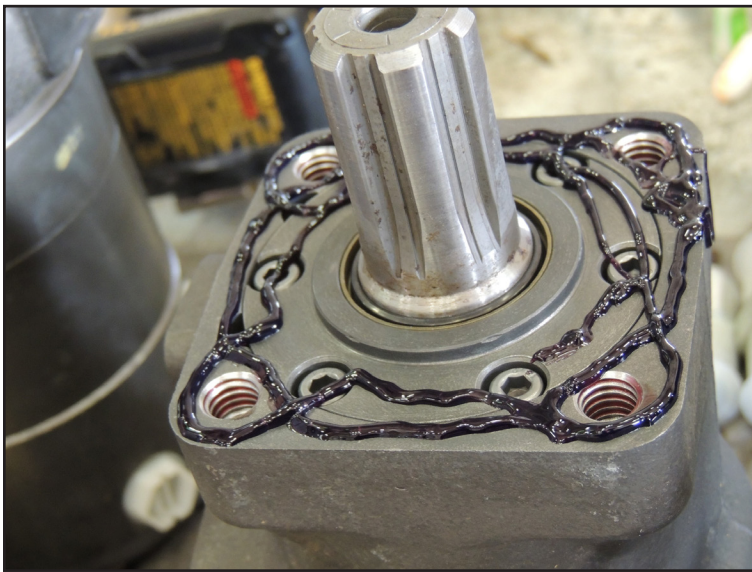

Figure 9

Apply Loctite® 515 to the flange of each motor.

6. Apply Loctite® 515 Gasket Eliminator on the flat side (mating side) of each 4-hole bearing retainer plate (Figure 10). Follow the directions on the Loctite® packaging.



Figure 10

Apply Loctite® 515 to the 4-hole bearing retainer plate.

7. Apply Loctite® 680 on the (flat) **outside edge** of the motorshaft support bearings (see Figure 11 and Figure 12). Follow the directions on the Loctite® packaging.
8. Insert the motorshaft support bearing into the large motor shaft hole on the grabber carriage assembly (the hole you already prepped) (see Figure 6). Use the bearing retainer to assist in locating the bearing position. Do this on both motor shaft holes — one bearing per large hole.



Figure 11

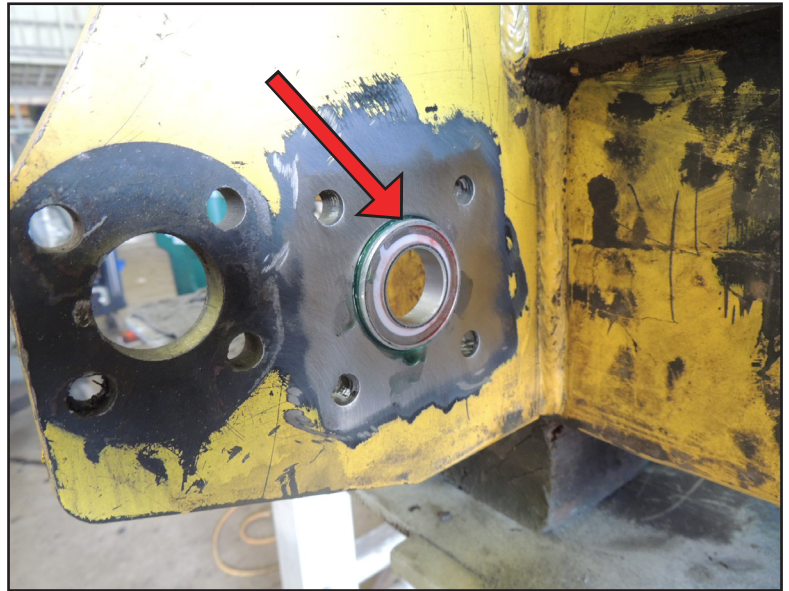

Figure 12

Insert the support bearing in the large hole that is already prepped.
 NOTE: The visible green gel is Loctite® 680.

3.2 Installing the Motors and Grabber Gear on the Grabber

NOTE: The drive motor is **always placed on the left side** and the brake motor is **always placed on the right side** of the grabber carriage assembly when you are facing the back of the grabber assembly.

1. Install the 4-hole bearing retainer plate to the **inside of the grabber carriage assembly over the motorshaft support bearing** (Figure 13). The Loctite® applied side of the plate must be against the grabber carriage assembly. Follow the directions on the Loctite® packaging. The large hole in the bearing retainer plate matches the location with the large hole on the grabber assembly. **Repeat on the other inside side of the grabber carriage assembly.**
2. **Drive Motor:** Install the **drive motor** in place on the grabber carriage assembly on the **left side** (Figure 13). Install the motor just enough to allow the thrust washer (when it is installed in the next step) to hang on the shaft.

NOTE: Remember the **hydraulic tube ports on the motor must be facing UP**. The motor's flange side with the Loctite must be placed flush against the outside of the carriage assembly with the motor spline pushed through the large hole.

3. Install a thrust washer in place around the drive motor spline on the **inside side** (Figure 13).

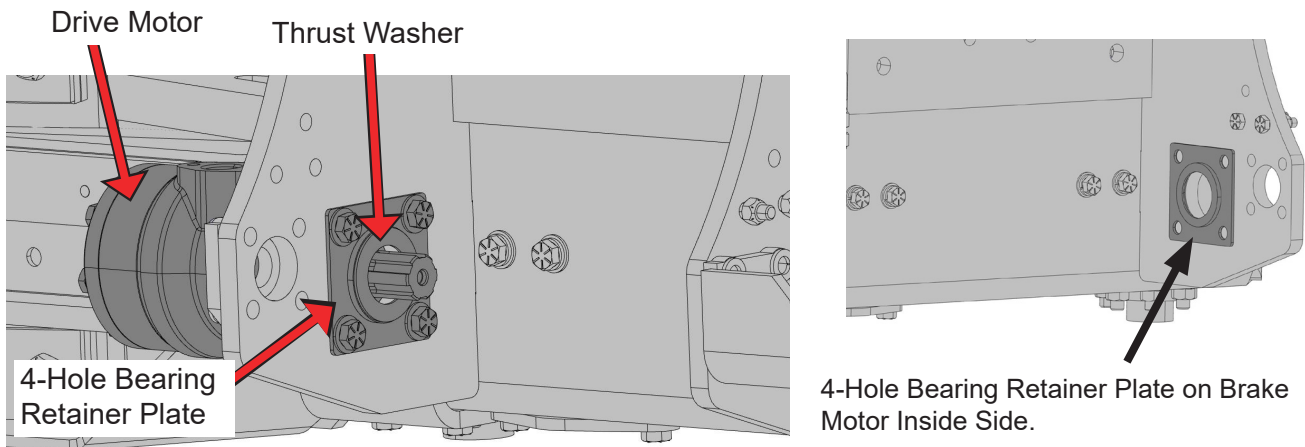

Figure 13

Install the drive motor with the spline going through the large hole. Add the thrust washer.

4. Apply Loctite® 263 according to the directions on the Loctite® packaging to each bolt (PN 1136593).
5. Install a washer (PN 1710079) on the bolt (PN 1136593) and screw the bolt into the mounting hole of the motor.
6. Use a torque wrench with a 9/16" socket to tighten the bolts to 44 ft.-lbs. Do this in a crisscrossing tightening pattern (Figure 16).
7. Repeat Steps 4-6 on the remaining three (3) bolts of this motor and again for the other motor and its (4) bolts.
8. Install the grabber gear onto the drive motor spline (Figure 14).

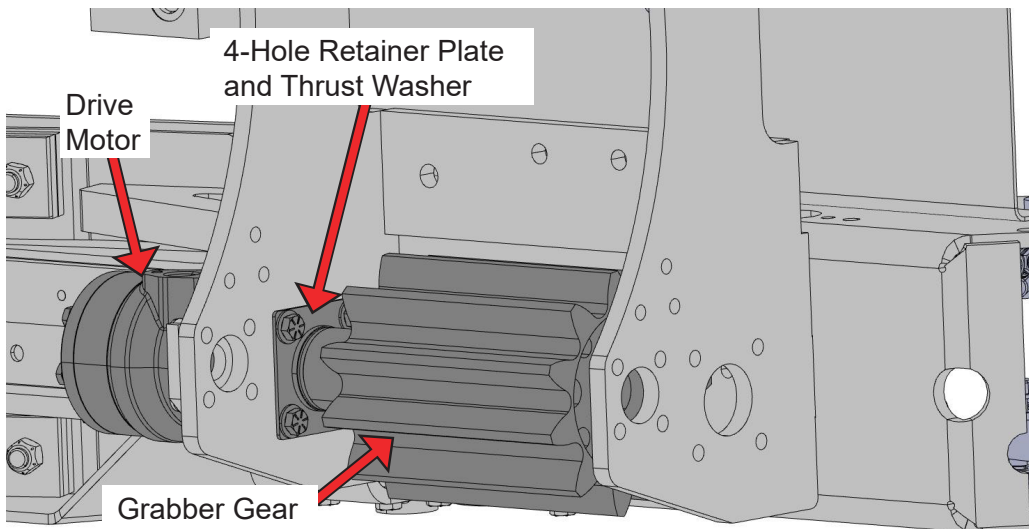

Figure 14

9. Apply Loctite® 263 to each bolt according to the directions on the Loctite® packaging.
10. **Brake Motor:** Install the **brake motor** on the right side of the grabber assembly. Do not push the motor flush against the grabber assembly until the thrust washer is installed (see Step 11) (Figure 15). It may be necessary to turn the drive motor enough to correctly position the spline to allow the brake motor to be installed.

NOTE: Remember the **hydraulic tube ports on the motor must be facing UP**. The motor's flange side with the Loctite must be placed flush against the outside of the carriage assembly with the motor spline pushed through the large hole.

11. Install a thrust washer in place around the brake motor spline (Figure 15).

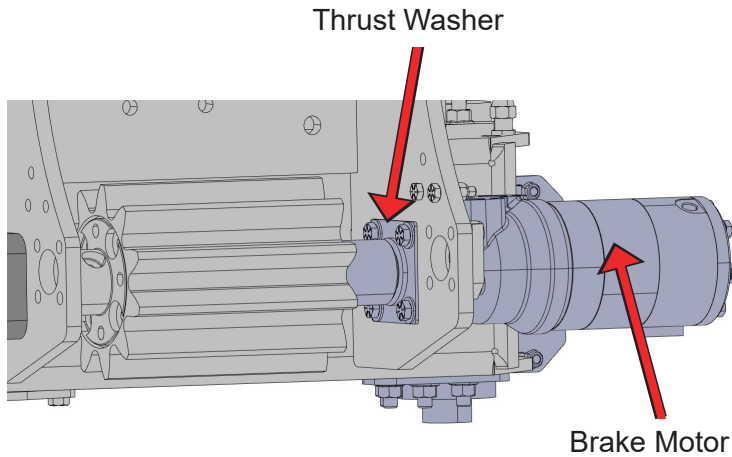

Figure 15

Install the thrust washer between the spline of the brake motor and the grabber gear.

12. Apply Loctite® 263 according to the directions on the Loctite® packaging to each bolt and each threaded hole in the motor housing.
13. Once the motor splines are aligned, use a rubber mallet to push the splines into the grabber gear, then seat the motor.
14. Use a torque wrench with a 9/16” socket to tighten the bolts to 51 ft.-lbs. Do this in a crisscrossing tightening pattern (Figure 16).

Tightening Pattern

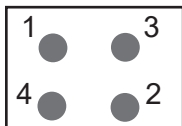

Figure 16

15. Strike against the ends of both motors using the rubber mallet to seat all parts again.
16. Use the torque socket wrench again to tighten the bolts to 51 ft.-lbs.
17. Repeat Steps 15 and 16 until there is no movement from the socket wrench.
18. Center the grabber gear by placing a rolling head (centering) pry bar through the open hole next to the motor/ grabber gear on the grabber assembly contacting the metal part of the grabber gear (Figure 17) — **NOT against the plastic grabber gear!** Strike the pry bar with the rubber mallet to center the grabber gear. Striking and aligning the motors may force the grabber gear into misalignment. Striking the grabber gear will realign it to the center.



Figure 17

19. Grease the couplers on the gear with EP No. 2 lithium grease (Figure 18).

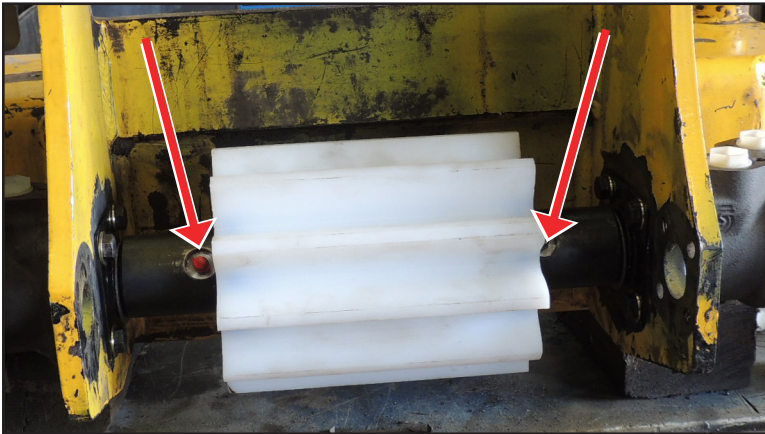

Figure 18
Grease points.

20. If you replaced an existing motor with a new motor, remove the shipping plug and washer before installing hydraulic lines (Figure 19).



Figure 19

21. Use the crane to position the grabber assembly in location on the ZR mast.
22. Reinstall all four roller sets: the bracket (the upper brackets have an angled bump stop; the lower brackets do not), roller (if it slid out during disassembly from the mast).
23. Apply Loctite 263 according to the directions on the Loctite® packaging to the **new** bolts (PN 1427860) (quantity 16) and washers (PN 1710079) and to the four holes in each roller and install the rollers.
24. Use a torque wrench to torque each bolt to 45 ft.-lbs.
25. Reinstall the grease zerks into each roller.
26. Reinstall the proximity switch flag bracket and hardware if previously installed.
27. Use a torque wrench to torque each bolt to 23 ft.-lbs.
28. Remove the chains and crane.
29. Route and reattach all hydraulic lines on the grabber assembly in the correct routing positions.
30. Remove your company's Lockout/Tagout procedure. If your company does not have a Lockout/Tagout procedure, follow OSHA 1910.147 and 1910.146 Confined Space as appropriate.
31. Run the arm and grabber functions, checking for proper function.
 - If the arm and grabber do not function correctly, call your McNeilus refuse service network representative at 888-686-7278 for further instruction.
32. Check for leaks at the hydraulic fittings. Tighten fittings as needed.
33. Reinstall the grabber faceplate using the retained hardware.
34. Use a torque wrench to torque bolts to 15 ft.-lbs.
35. Return vehicle to service after ensuring there are no leaks and the arm and grabber function correctly.