

# Uncontrolled Copy

**ID #** CBR-2583

**Version** 1

---

## Title

Tire Pressure Monitoring System U101A / U101B Fault Solution - VN (4) - AN (4) - PR

## Abstract

The purpose of this CBR is to assist in diagnosing Tire Pressure Monitoring System (TPMS) DTCs U101A / U101B as well as instructions to replace the TPMS Range Extends and Wireless Sensor Gateway if it is determined it is required.

## Content

Published 26 May 2026

## Valid For

Mack Chassis - PR, AN(4)

Volvo Chassis - VN (4)

Model Year - 2024 to current

The purpose of this CBR is to assist in diagnosing Tire Pressure Monitoring System (TPMS) DTCs U101A / U101B as well as instructions to replace the TPMS Range Extends and Wireless Sensor Gateway if it is determined it is required.

## Procedure: TPMS U101A/U101B Fault Solution

1. Connect the truck to PTT. Ensure that the following is used.
  - a. Premium Tech Tool (PTT) (Latest Version)
  - b. Vocom II Tough: 88894400
  - c. USB cable: 88890313
  - d. 16-pin OBD cable: 88894001 (blue end)
2. Verify connection to the truck:

The screenshot displays the 'Tech Tool' software interface. At the top, there is a navigation bar with tabs for 'Product', 'Product History', 'Diagnose', 'Test', 'Calibrate', 'Program', and 'Impact'. The 'Product' tab is currently selected. Below the navigation bar, the 'Selected Product (NR 631025)' is shown. The interface is divided into several sections:

- Product Details:** A table-like view showing key information:

Chassis ID: NR 631025	VIN: 4V4BC9EJXRN631025
Model: VN (4)	Company: Volvo Trucks
Emission Level: US24 + OBD2024	Mileage: 2160.2 miles
Electrical System: VERSION4	
- Product Status:** A list of status messages with timestamps:
  - DTCs with status Active. Click Diagnose to view DTCs. (1/10/2025 9:51 AM)
  - Control unit information. Details >> (1/10/2025 10:21 AM)
  - Current battery level: 27.6 V. (1/10/2025 10:21 AM)
  - Control unit software update available. Update >> (1/10/2025 8:18 AM)
- Connectivity:** A list of connection events:
  - Communication unit: VCCOM II Tough (USB) is connected to the computer.
  - Product: The selected product NR 631025 is connected. (1/10/2025 8:18 AM)
  - Central Data: Central Data Retrieved. (1/10/2025 8:18 AM)
- Campaigns (0):** A section indicating that there are no available campaigns for this product.

At the bottom of the interface, a status bar shows 'Chassis ID: NR 631025 VIN: 4V4BC9EJXRN631025 Work Order: 1234567' and 'Product Online' status.

3. Open the Program Tab, select Parameter Programming, and Press Start:

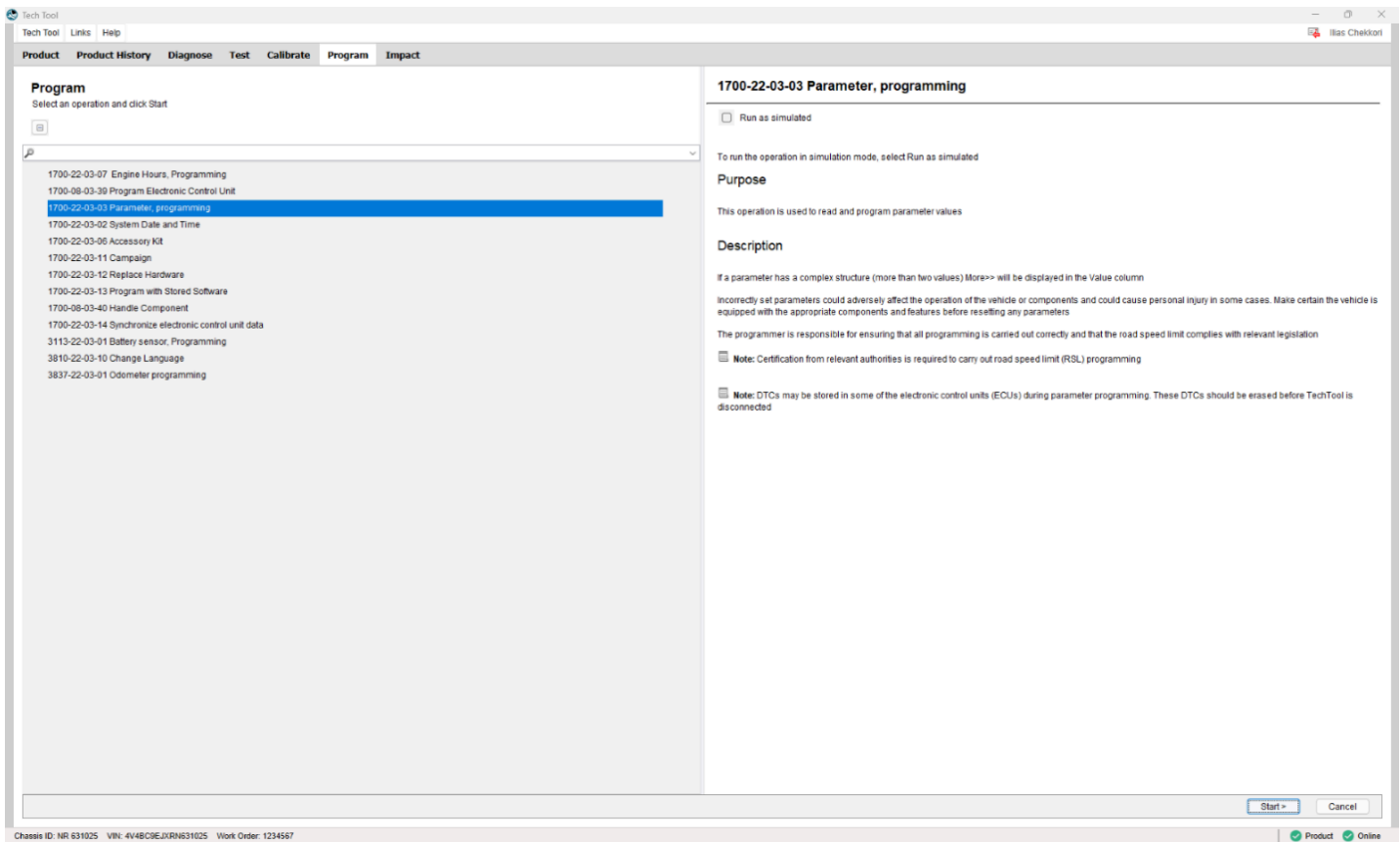

4. Once loaded, select the Wireless Sensor Gateway (WSGW) under the Control Unit field:

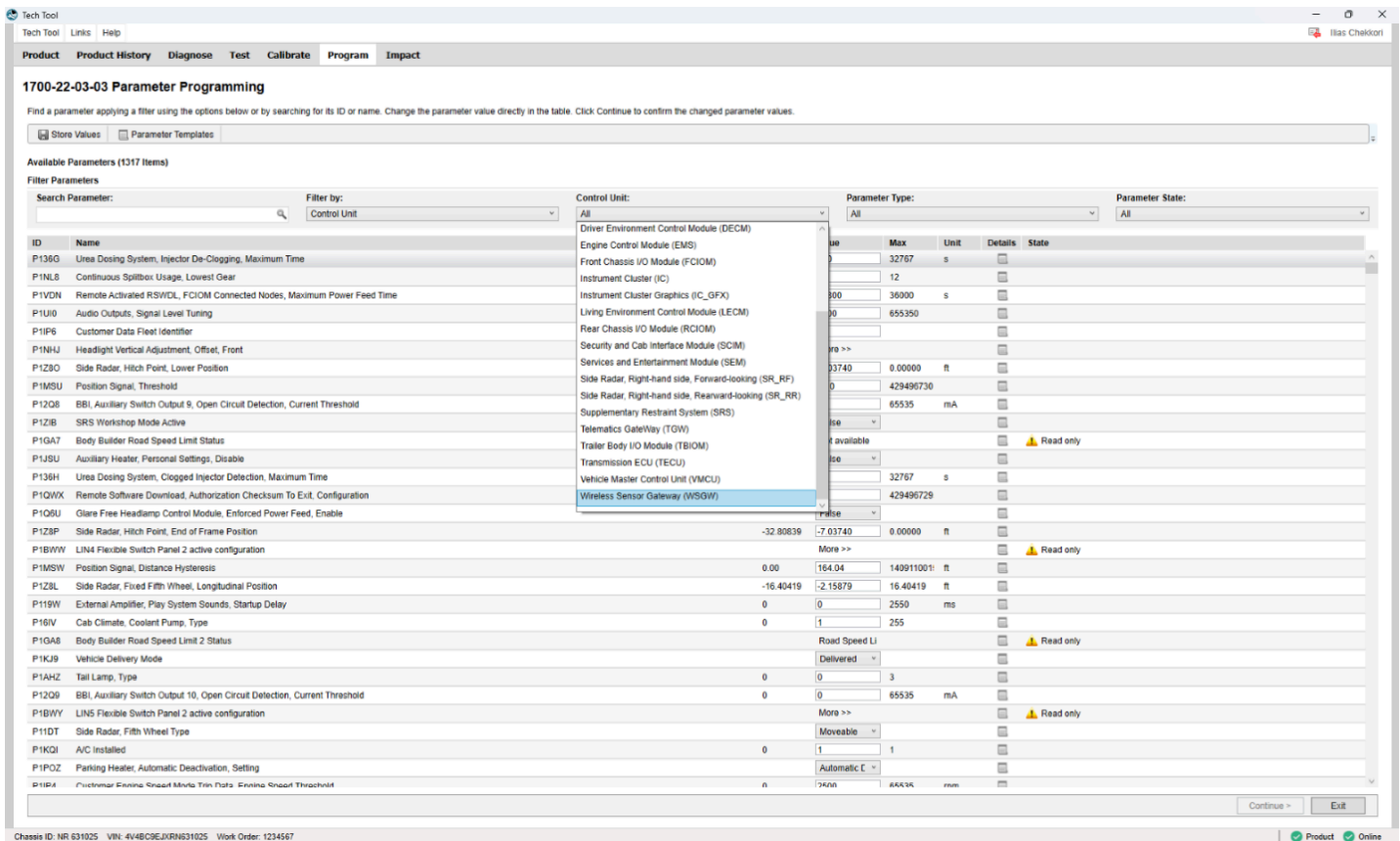

5. Locate the P156K and P156M parameters.



**1700-22-03-03 Parameter Programming**

Find a parameter applying a filter using the options below or by searching for its ID or name. Change the parameter value directly in the table. Click Continue to confirm the changed parameter values.

Store Values | Parameter Templates | Invalid Parameters

**Invalid Parameter Value**  
There are one or more parameters with invalid values. This may be caused by several reasons and some vehicle functions may not function properly. Click on Invalid Parameters button to see more details.

Available Parameters (17 Items)

Filter Parameters

Search Parameter:  Filter by:  Control Unit:  Parameter Type:  Parameter State:

ID	Name	Min	Value	Max	Unit	Details	State
P106I	Tire Pressure Monitoring, Range Extenders Installed, Thread Network Status		More >>				Read only
P1LWM	TPMS Wheel Module Identification Numbers		More >>				
P1YQN	Tire Pressure Monitoring, Over Pressure Warning, Configuration		More >>				
P1YQL	Tire Pressure Monitoring, Eco Under Pressure Warning, Configuration		More >>				
P1YQJ	Tire Pressure Monitoring, Low Pressure Warning, Configuration		More >>				
P1YQK	Tire Pressure Monitoring, Extreme Under Pressure Warning, Configuration		More >>				
P1YQO	Tire Pressure Monitoring, Fast Pressure Loss Warning, Configuration		More >>				
P1YQD	Tire Pressure Monitoring, Reference Pressure, Axle 1	42.07	123.26	145.03	psi		
P1YQE	Tire Pressure Monitoring, Reference Pressure, Axle 2	42.07	110.23	145.03	psi		
P1YQF	Tire Pressure Monitoring, Reference Pressure, Axle 3	42.07	110.23	145.03	psi		
P1YQG	Tire Pressure Monitoring, Reference Pressure, Axle 4	42.07	72.52	145.03	psi		
P1YQH	Tire Pressure Monitoring, Reference Pressure, Axle 5	42.07	72.52	145.03	psi		
P10PU	Tire Pressure Monitoring, Auto-Location, Thread Network Formation, Configuration		More >>				
P1YQP	Tire Pressure Monitoring, High Tire Temperature Warning, Configuration		More >>				
P1272	Tire Pressure Monitoring System, Auto Location Function, Enable		False				
P156K	TPMS, Range Extenders ID, Configuration		More >>				Changed
P156M	TPMS, Range Extenders Location, Configuration		More >>				Changed

Continue > | Exit

Chassis ID: 1HR 640276 VIN: 4V4BC9EJ6SN640276 Work Order: test

6. Open these parameters and record the values in P156K and P156M exactly as they appear. There may be 1 or 2 values in each parameter, depending on the truck configuration. This step is vital for recommissioning.

Examples Only: **Do not use the number pictured**

Complex Parameter

### Parameter Programming

ID	Name
P156K	TPMS, Range Extende
First Range Extender Product ID	<input type="text" value="01518002924000340001"/>
Second Range Extender Product ID	<input type="text" value="01518002924000160001"/>
Third Range Extender Product ID	<input type="text"/>
Fourth Range Extender Product ID	<input type="text"/>
Fifth Range Extender Product ID	<input type="text"/>

Complex Parameter

### Parameter Programming

ID	Name
P156M	TPMS, Range Extenders Locatio
First Range Extender Product Location	Min 0 <input type="text" value="55"/> Max 255
Second Range Extender Product Location	Min 0 <input type="text" value="57"/> Max 255
Third Range Extender Product Location	Min 0 <input type="text" value="0"/> Max 255
Fourth Range Extender Product Location	Min 0 <input type="text" value="0"/> Max 255
Fifth Range Extender Product Location	Min 0 <input type="text" value="0"/> Max 255

Use these tables to copy the values if needed:



Position	P156K
First Range Extender Product ID	

(if applicable) Second Range Extender Product ID	
--	--

<b>Position</b>	<b>P156M</b>
First Range Extender Product Location	
(if applicable) Second Range Extender Product Location	

**Important Note**  
**It is VERY important that the parameter values be recorded before proceeding**

7. Once the P156K and P156M parameter values are recorded, set the P156K values to blank, and the P156M values to 0.

Examples below:

Complex Parameter

### Parameter Programming

ID	Name
P156K	TPMS, Range Extenders
First Range Extender Product ID	<input type="text"/>
Second Range Extender Product ID	<input type="text"/>
Third Range Extender Product ID	<input type="text"/>
Fourth Range Extender Product ID	<input type="text"/>
Fifth Range Extender Product ID	<input type="text"/>

Complex Parameter

### Parameter Programming

ID	Name
P156M	TPMS, Range Extenders
First Range Extender Product Location	Min 0 <input type="text"/> Max 255
Second Range Extender Product Location	Min 0 <input type="text"/> Max 255
Third Range Extender Product Location	Min 0 <input type="text"/> Max 255
Fourth Range Extender Product Location	Min 0 <input type="text"/> Max 255
Fifth Range Extender Product Location	Min 0 <input type="text"/> Max 255

8. Once the value changes have been made, program them into the truck to complete the decommissioning.

9. To allow the system to completely decommission, leave the key in the on/run position for no less than 15 minutes before continuing to the next step.

Live UI

10. After 15 minutes, turn off the ignition, then the master disconnect switch. Wait for 3 minutes, and power the truck back on.
11. Reload the parameters and locate the P156K and P156M parameters.
12. Input the values recorded at step 5.
13. Program the values.

Examples Only: **Do not use the number pictured.**

Complex Parameter

### Parameter Programming

ID	Name
P156K	TPMS, Range Extende
First Range Extender Product ID	<input type="text" value="01518002924000340001"/>
Second Range Extender Product ID	<input type="text" value="01518002924000160001"/>
Third Range Extender Product ID	<input type="text"/>
Fourth Range Extender Product ID	<input type="text"/>
Fifth Range Extender Product ID	<input type="text"/>

Complex Parameter

### Parameter Programming

ID	Name
P156M	TPMS, Range Extenders Locatio
First Range Extender Product Location	Min 0 <input type="text" value="55"/> Max 255
Second Range Extender Product Location	Min 0 <input type="text" value="57"/> Max 255
Third Range Extender Product Location	Min 0 <input type="text" value="0"/> Max 255
Fourth Range Extender Product Location	Min 0 <input type="text" value="0"/> Max 255
Fifth Range Extender Product Location	Min 0 <input type="text" value="0"/> Max 255

14. To allow the system to complete commission, leave the key in the on/run position for no less than 15 minutes before continuing to the next step.
15. After 15 minutes, turn off the ignition, then the master disconnect switch. Wait for 3 minutes, and power the truck back on.
16. Clear faults.
17. Perform a 15-minute test drive.
18. Verify that he DTCs did not return.
  - a. DTCs did not return - repair is complete
  - b. DTCs di return - continue to WSGW and Range Extender replacement procedure

### Procedure: Wireless Sensor Gateway (WSGW) and Range Extender Replacement

 Live UI : the ignition is in the off position

2. Switch the master disconnect switch to the off position
3. Disconnect the WSGW connector. Leave disconnect until the installation of the new WSGM in step 15.

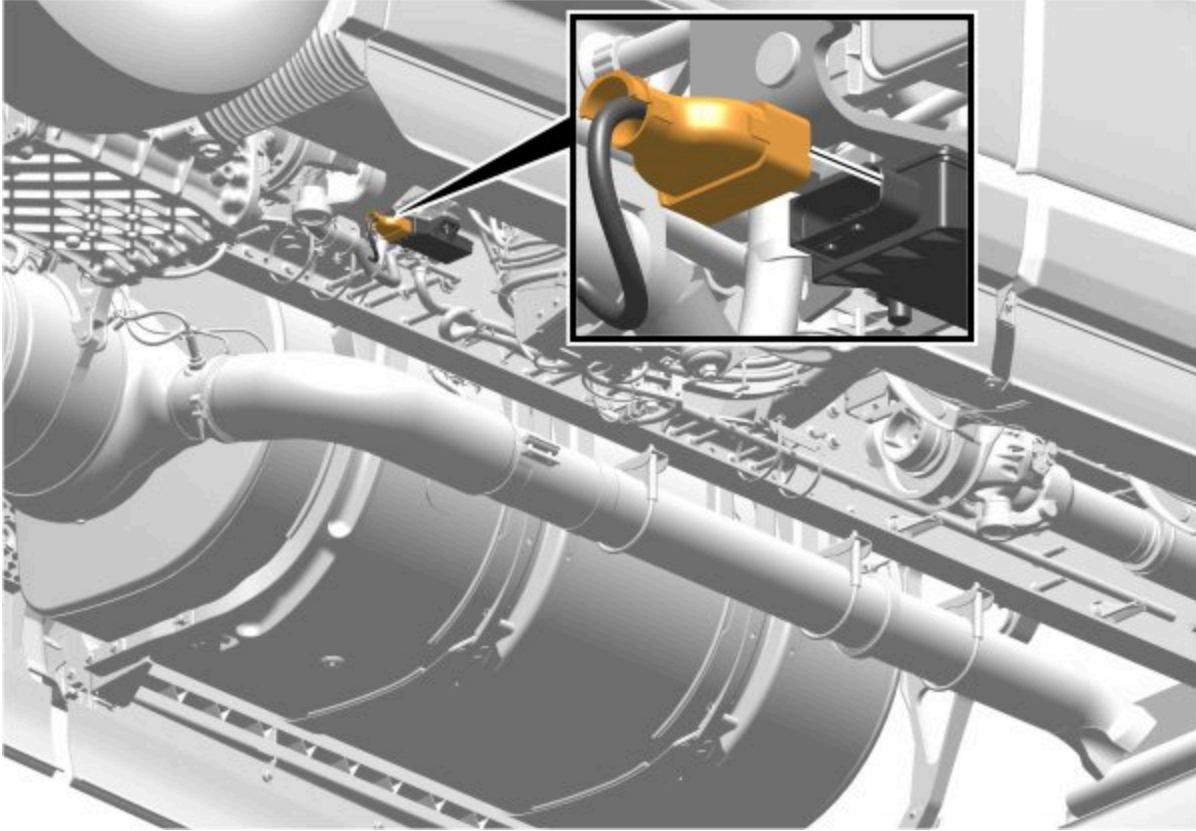

4. Remove the WSGW.

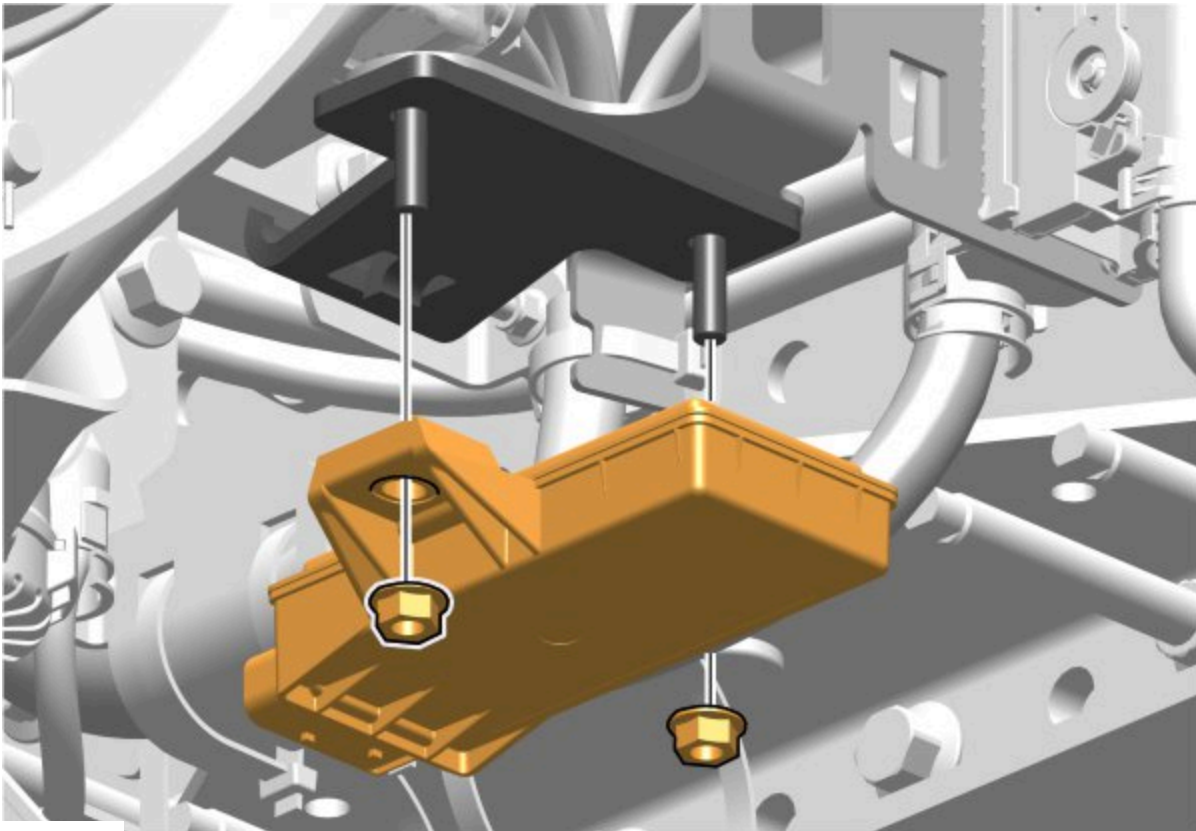

 Live UI

5. Disconnect the range extender connector. Leave disconnected until the installation of the new extenders in step 17. (Trucks may have one or two range extenders, disconnect all)

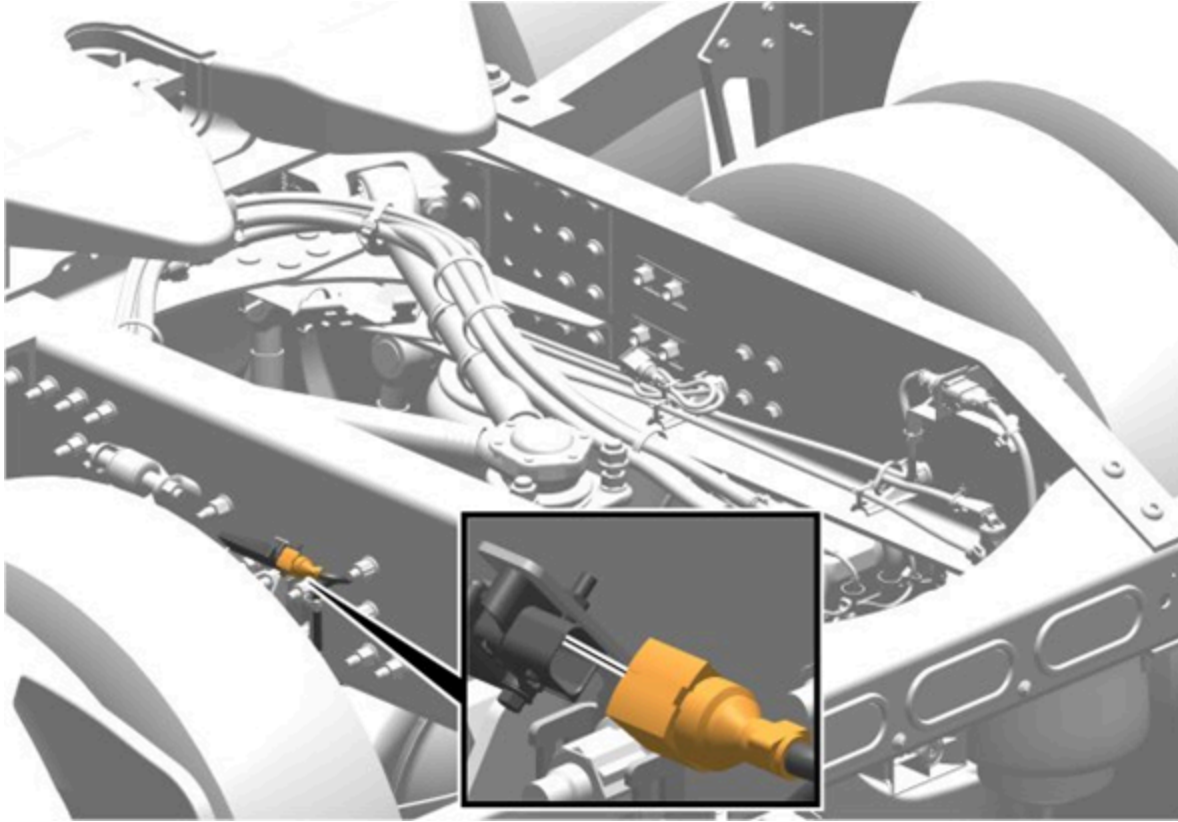

6. Remove the Range Extenders.

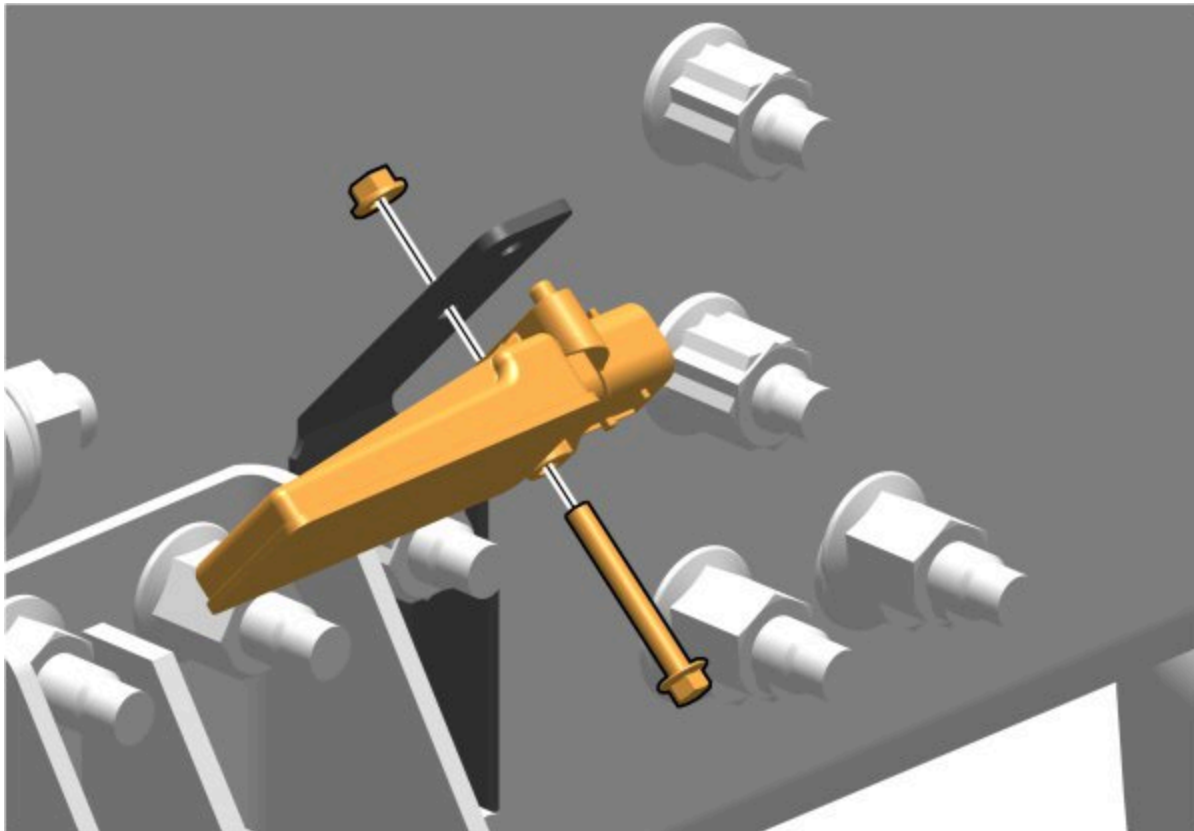

 Live UI  the master disconnect switch.

8. Turn the ignition to the on position.
9. If the truck was previously connected to PTT, remove it from the "Latest Selection " list.
10. Connect the truck to PTT. Ensure that the following is used.
  - a. Premium Tech Tool (PTT) (Latest Version)
  - b. Vocom II Tough: 88894400
  - c. USB cable: 88890313
  - d. 16-pin OBD cable: 88894001 (blue end)
11. Verify that PTT displays a hardware mismatch in the control unit information screen due to the unplugged WSGW.
12. Select the Programming tab and select Replace Hardware.
13. Select WSGW.

Tech Tool Links Help

Product Product History Diagnose Test Calibrate Program Impact

### Program

Select an operation and click Start

- Guided Parameter Programming
  - 1700-22-03-07 Engine Hours, Programming
  - 1700-08-03-39 Program Electronic Control Unit
  - 1700-22-03-03 Parameter, programming
  - 1700-22-03-02 System Date and Time
  - 1700-22-03-06 Accessory Kit, Programming
  - 1700-22-03-11 Campaign
  - 1700-22-03-12 Replace Hardware**
  - 1700-22-03-13 Program with Stored Software
  - 1700-08-03-40 Handle Component
  - 1700-22-03-14 Synchronize electronic control unit data
- 3113-22-03-01 Battery sensor, Programming
- 3810-22-03-10 Change Language
- 3837-22-03-01 Odometer programming

14. Follow the prompts, follow the steps below to install the new hard one prompted to do so.
15. Install the new WSGW.

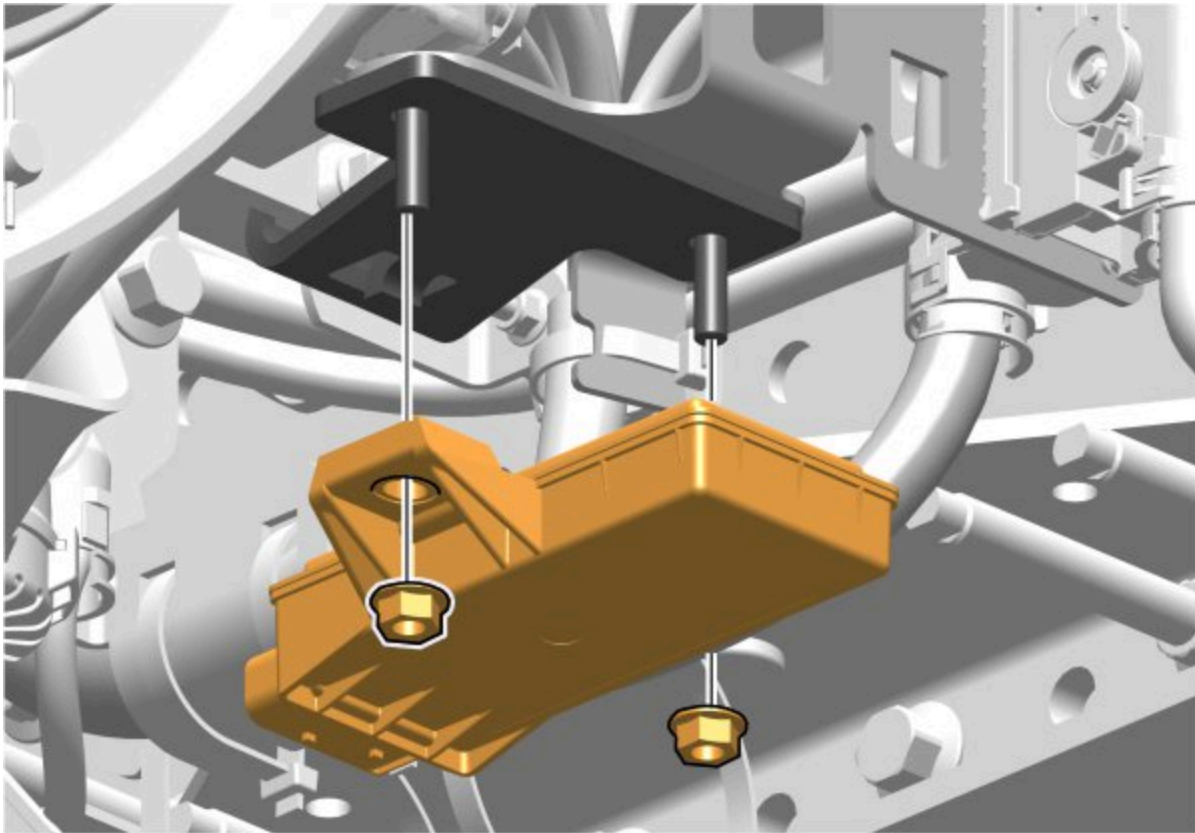

16. Connect the connector.

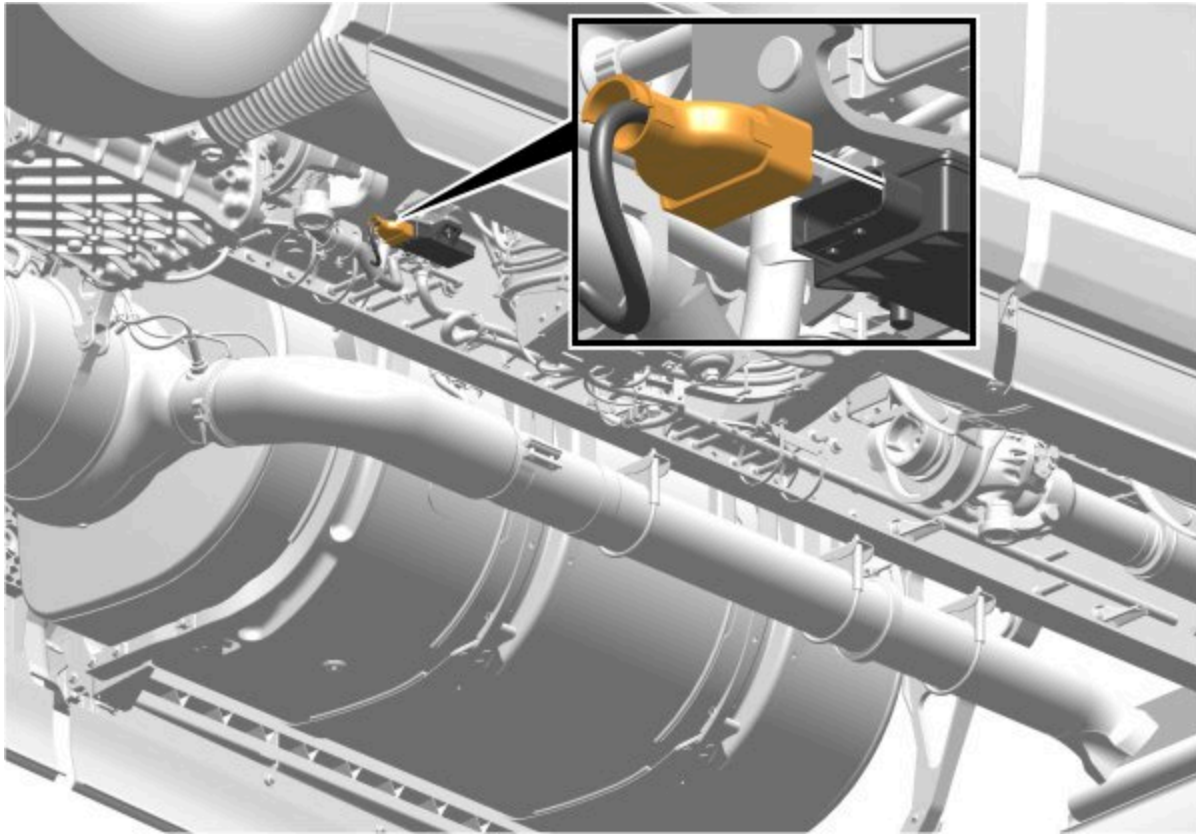

17. Install new Range Extender/s.

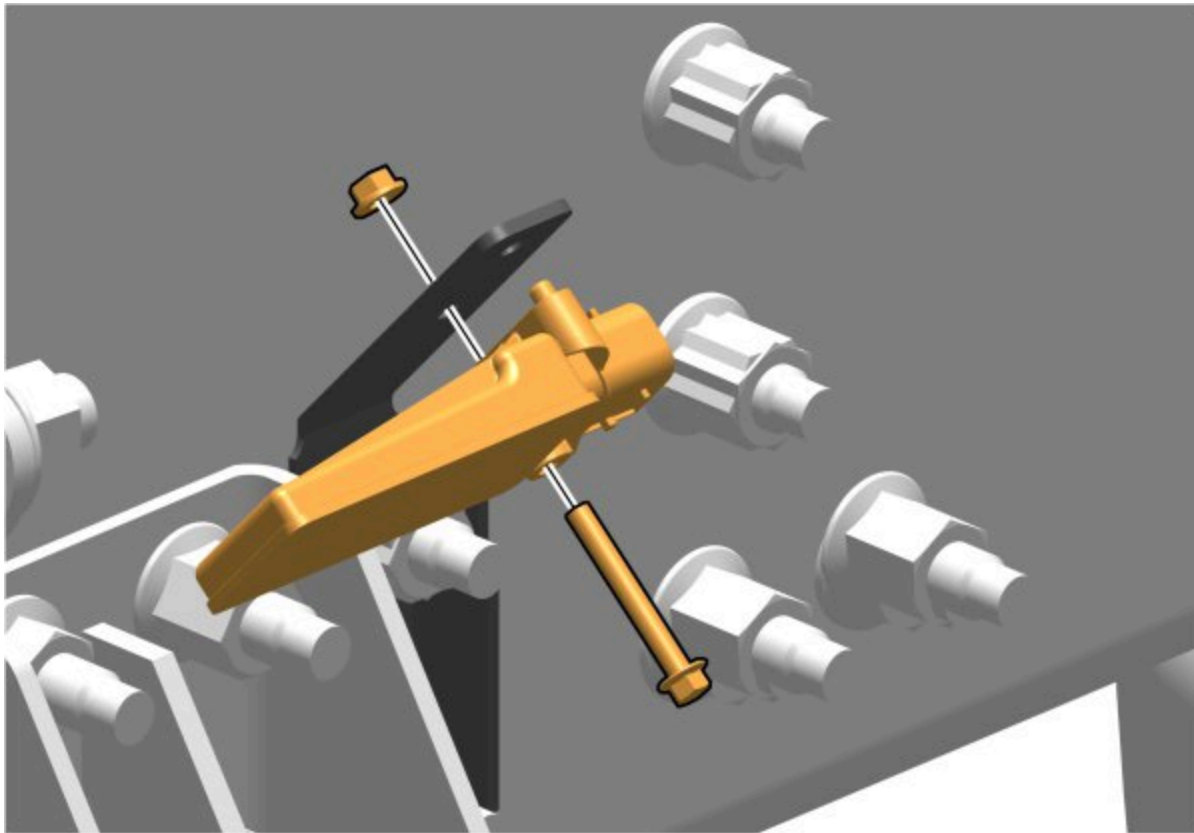

18. Connect the connector/s.

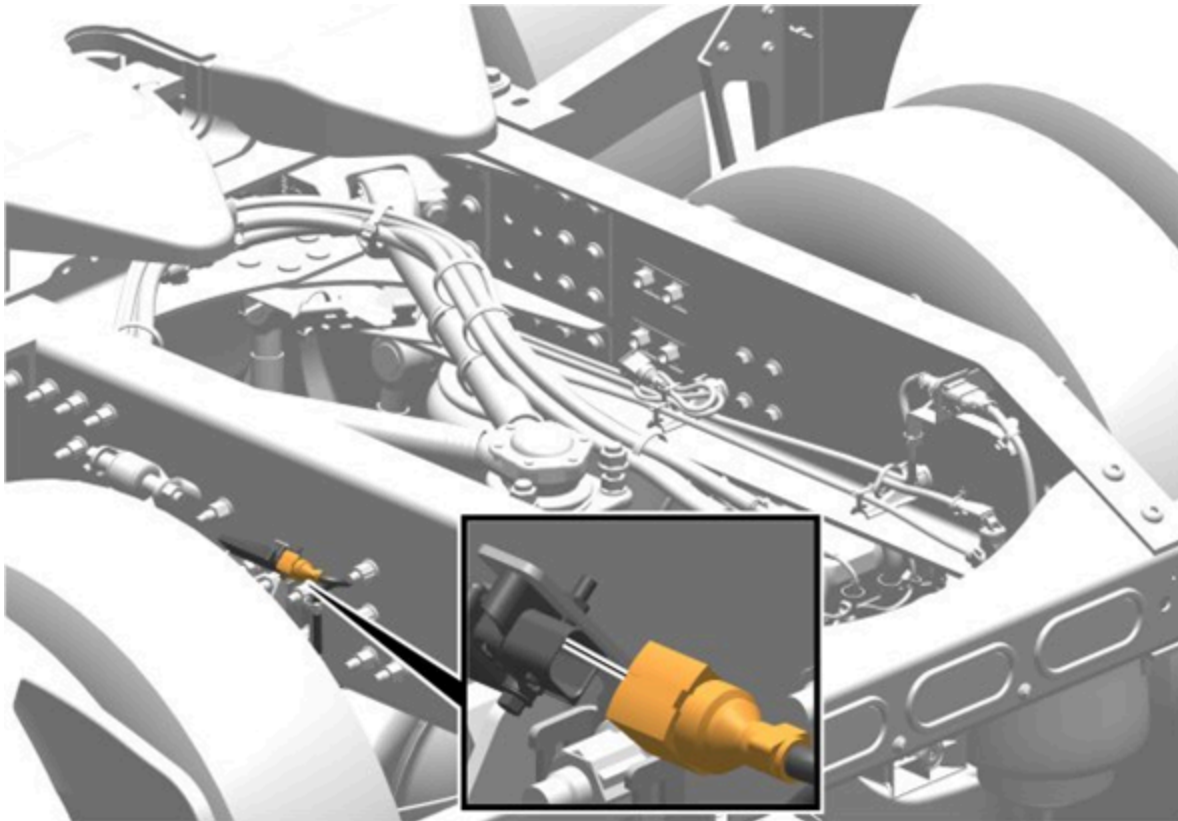

19. Open the Program Tab, select Parameter Programming, and Press Start:

**Program**  
Select an operation and click Start

1700-22-03-07 Engine Hours, Programming  
1700-09-03-39 Program Electronic Control Unit  
**1700-22-03-03 Parameter, programming**  
1700-22-03-02 System Date and Time  
1700-22-03-06 Accessory Kit  
1700-22-03-11 Campaign  
1700-22-03-12 Replace Hardware  
1700-22-03-13 Program with Stored Software  
1700-09-03-40 Handle Component  
1700-22-03-14 Synchronize electronic control unit data  
3113-22-03-01 Battery sensor, Programming  
3810-22-03-10 Change Language  
3837-22-03-01 Odometer programming

**1700-22-03-03 Parameter, programming**

Run as simulated

To run the operation in simulation mode, select Run as simulated

**Purpose**  
This operation is used to read and program parameter values

**Description**  
If a parameter has a complex structure (more than two values) More>> will be displayed in the Value column  
Incorrectly set parameters could adversely affect the operation of the vehicle or components and could cause personal injury in some cases. Make certain the vehicle is equipped with the appropriate components and features before resetting any parameters  
The programmer is responsible for ensuring that all programming is carried out correctly and that the road speed limit complies with relevant legislation

**Note:** Certification from relevant authorities is required to carry out road speed limit (RSL) programming

**Note:** DTCs may be stored in some of the electronic control units (ECUs) during parameter programming. These DTCs should be erased before TechTool is disconnected

Start > Cancel

20. Once loaded, select the Wireless Sensor Gateway (WSGW) under the Control Unit field:

**1700-22-03-03 Parameter Programming**  
Find a parameter applying a filter using the options below or by searching for its ID or name. Change the parameter value directly in the table. Click Continue to confirm the changed parameter values.

Store Values Parameter Templates

**Available Parameters (1317 Items)**

**Filter Parameters**  
Search Parameter: Filter by: Control Unit

**Control Unit:**  
All  
Driver Environment Control Module (DECM)  
Engine Control Module (EMS)  
Front Chassis I/O Module (FCIOM)  
Instrument Cluster (IC)  
Instrument Cluster Graphics (IC GFX)  
Living Environment Control Module (LECM)  
Rear Chassis I/O Module (RCIOM)  
Security and Cab Interface Module (SCIM)  
Services and Entertainment Module (SEM)  
Side Radar, Right-hand side, Forward-looking (SR\_RF)  
Side Radar, Right-hand side, Rearward-looking (SR\_RR)  
Supplementary Restraint System (SRS)  
Telematics GateWay (TGW)  
Trailer Body I/O Module (TBIOM)  
Transmission ECU (TECU)  
Vehicle Master Control Unit (VMCU)  
**Wireless Sensor Gateway (WSGW)**

ID	Name	Value	Max	Unit	Details	State
P136G	Urea Dosing System, Injector De-Clogging, Maximum Time	0	32767	s		
P1NL8	Continuous Spillbox Usage, Lowest Clear	0	12			
P1VDN	Remote Activated RSWDL, FCIOM Connected Nodes, Maximum Power Feed Time	800	36000	s		
P1UJ0	Audio Outputs, Signal Level Tuning	0	655350			
P1P16	Customer Data Fleet Identifier					
P1NHJ	Headlight Vertical Adjustment, Offset, Front					
P1Z80	Side Radar, Hitch Point, Lower Position	0	0.00000	ft		
P1MSU	Position Signal, Threshold	0	429496730			
P12Q8	BBI Auxiliary Switch Output 9, Open Circuit Detection, Current Threshold		65535	mA		
P1Z1B	SRS Workshop Mode Active					
P1GA7	Body Builder Road Speed Limit Status					Read only
P1JSU	Auxiliary Heater, Personal Settings, Disable					
P136H	Urea Dosing System, Clogged Injector Detection, Maximum Time		32767	s		
P1QWX	Remote Software Download, Authorization Checksum To Exit, Configuration		429496728			
P1Q5U	Olare Free Headlamp Control Module, Enforced Power Feed, Enable					
P1Z8P	Side Radar, Hitch Point, End of Frame Position	-32.80839	-7.03740	0.00000	ft	
P18WW	LIN4 Flexible Switch Panel 2 active configuration					Read only
P1MSW	Position Signal, Distance Hysteresis	0.00	164.04	149911001	ft	
P1Z8L	Side Radar, Fixed Fifth Wheel, Longitudinal Position	-16.40419	-2.15879	16.40419	ft	
P119W	External Amplifier, Play System Sounds, Startup Delay	0	0	2550	ms	
P16IV	Cab Climate, Coolant Pump, Type	0	1	255		
P1QAB	Body Builder Road Speed Limit 2 Status					Read only
P1KJ9	Vehicle Delivery Mode		Delivered			
P1AHZ	Tail Lamp, Type	0	0	3		
P12Q6	BBI Auxiliary Switch Output 10, Open Circuit Detection, Current Threshold	0	0	65535	mA	
P18WY	LIN5 Flexible Switch Panel 2 active configuration					Read only
P11DT	Side Radar, Fifth Wheel Type					
P1KQI	A/C Installed	0	1	1		
P1POZ	Parking Heater, Automatic Deactivation, Setting				Automatic C	
P18P4	Functioner Engine Speed Minis Trim Ticks Engine Speed Threshold					

Continue > Exit

21. Locate the P156K and P156M parameters.



The screenshot shows the 'Tech Tool' application window with the 'Program' tab selected. The main heading is '1700-22-03-03 Parameter Programming'. Below this, there are options to 'Store Values', 'Parameter Templates', and 'Invalid Parameters'. A warning message states: 'Invalid Parameter Value. There are one or more parameters with invalid values. This may be caused by several reasons and some vehicle functions may not function properly. Click on Invalid Parameters button to see more details.'

The 'Available Parameters (17 Items)' section includes a 'Filter Parameters' area with dropdowns for 'Control Unit' (Wireless Sensor Gateway (WSGW)) and 'Parameter Type' (All). Below this is a table of parameters:

ID	Name	Min	Value	Max	Unit	Details	State
P106I	Tire Pressure Monitoring, Range Extenders Installed, Thread Network Status		More >>				Read only
P1LWM	TPMS Wheel Module Identification Numbers		More >>				
P1YQN	Tire Pressure Monitoring, Over Pressure Warning, Configuration		More >>				
P1YQL	Tire Pressure Monitoring, Eco Under Pressure Warning, Configuration		More >>				
P1YQJ	Tire Pressure Monitoring, Low Pressure Warning, Configuration		More >>				
P1YQK	Tire Pressure Monitoring, Extreme Under Pressure Warning, Configuration		More >>				
P1YQO	Tire Pressure Monitoring, Fast Pressure Loss Warning, Configuration		More >>				
P1YQD	Tire Pressure Monitoring, Reference Pressure, Axle 1	42.07	123.26	145.03	psi		
P1YQE	Tire Pressure Monitoring, Reference Pressure, Axle 2	42.07	110.23	145.03	psi		
P1YQF	Tire Pressure Monitoring, Reference Pressure, Axle 3	42.07	110.23	145.03	psi		
P1YQG	Tire Pressure Monitoring, Reference Pressure, Axle 4	42.07	72.52	145.03	psi		
P1YQH	Tire Pressure Monitoring, Reference Pressure, Axle 5	42.07	72.52	145.03	psi		
P10PU	Tire Pressure Monitoring, Auto-Location, Thread Network Formation, Configuration		More >>				
P1YQP	Tire Pressure Monitoring, High Tire Temperature Warning, Configuration		More >>				
P1272	Tire Pressure Monitoring System, Auto Location Function, Enable		False				
P156K	TPMS, Range Extenders ID, Configuration		More >>				Changed
P156M	TPMS, Range Extenders Location, Configuration		More >>				Changed

Buttons for 'Continue >' and 'Exit' are located at the bottom right of the window. The status bar at the bottom shows 'Chassis ID: HR 640276 VIN: 4V4BC9EJ6SN640276 Work Order: test' and 'Product Online' status.

22. Open parameters P156K and P156M.

Examples:

This screenshot shows the 'Complex Parameter' view for P156K. The title is 'Parameter Programming'. The parameter name is 'TPMS, Range Extende'. The configuration fields are:

- First Range Extender Product ID: 01518002924000340001
- Second Range Extender Product ID: 01518002924000160001
- Third Range Extender Product ID: [Empty field]
- Fourth Range Extender Product ID: [Empty field]
- Fifth Range Extender Product ID: [Empty field]

This screenshot shows the 'Complex Parameter' view for P156M. The title is 'Parameter Programming'. The parameter name is 'TPMS, Range Extenders Locatio'. The configuration fields are:

- First Range Extender Product Location: Min 0 55 Max 255
- Second Range Extender Product Location: Min 0 57 Max 255
- Third Range Extender Product Location: Min 0 0 Max 255
- Fourth Range Extender Product Location: Min 0 0 Max 255
- Fifth Range Extender Product Location: Min 0 0 Max 255

23. Set the P156K values to blank, and the P156M values to 0.

Live UI below:

Complex Parameter

### Parameter Programming

ID	Name
P156K	TPMS, Range Extenders

First Range Extender Product ID

Second Range Extender Product ID

Third Range Extender Product ID

Fourth Range Extender Product ID

Fifth Range Extender Product ID

Complex Parameter

### Parameter Programming

ID	Name
P156M	TPMS, Range Extenders

First Range Extender Product Location Min 0  Max 255

Second Range Extender Product Location Min 0  Max 255

Third Range Extender Product Location Min 0  Max 255

Fourth Range Extender Product Location Min 0  Max 255

Fifth Range Extender Product Location Min 0  Max 255

24. Once the value changes have been made, program them into the truck to complete the decommissioning.
25. To allow the system to completely decommission, leave the key in the on/run position for no less than 15 minutes before continuing to the next step.
26. After 15 minutes, turn off the ignition, then the master disconnect switch. Wait for 3 minutes, and power the truck back on.
27. Reconnect to the truck and return the Parameter Programming.
28. Open parameter P156K TPMS, Range Extenders ID
29. Manually enter the Range Extender IDs - this number will be located on the back of the Range Extender, labeled "ID". **The numbers displayed below are for example only. Only use the number displayed on the new range extenders.**
  - a. First Range Extender Product ID = Driver Side (All trucks)
  - b. Second Range Extender Product ID = Passenger Side (Trucks with two extenders)



Complex Parameter

### Parameter Programming

ID	Name
P156K	TPMS, Range Extende
First Range Extender Product ID	<input type="text" value="01518002924000340001"/>
Second Range Extender Product ID	<input type="text" value="01518002924000160001"/>
Third Range Extender Product ID	<input type="text"/>
Fourth Range Extender Product ID	<input type="text"/>
Fifth Range Extender Product ID	<input type="text"/>

30. Open parameter P156M TPMS, Range Extenders location.

31. Manually enter the Range Extender Locations:

- a. First Extender Location = 55 (Driver Side) (All trucks)
- b. Second Extender ID = 57 (Passenger Side) (Trucks with two extenders)

Complex Parameter

### Parameter Programming

ID	Name
P156M	TPMS, Range Extenders Locatio
First Range Extender Product Location	Min 0 <input type="text" value="55"/> Max 255
Second Range Extender Product Location	Min 0 <input type="text" value="57"/> Max 255
Third Range Extender Product Location	Min 0 <input type="text" value="0"/> Max 255
Fourth Range Extender Product Location	Min 0 <input type="text" value="0"/> Max 255
Fifth Range Extender Product Location	Min 0 <input type="text" value="0"/> Max 255

32. Program the new values.

33. To allow the system to complete commission, leave the key in the on/run position for no less than 15 minutes before continuing to the next step.

34. After 15 minutes, turn off the ignition, then the master disconnect switch. Wait for 3 minutes, and power the truck back on.

35. To allow for complete pairing, allow the truck to be powered on for no less than 30 minutes.

After 30 minutes, clear any codes caused by the work performed and ensure that no TPMS faults return.

Live UI use the truck.

 Tags

mack

range extenders

tire pressure

tire pressure monitoring

tpms

u101a

u101b

volvo

wireless sensor gateway

wsgw

Categories 

Make and Model > Volvo > VN (4)

---

Make and Model > Mack > AN (4) - Anthem

---

Make and Model > Mack > PR - Pioneer