



INSTRUCTION TO SERVICE

ITS: 61724		May 12, 2026
SECTION:	260-BATTERY COMPARTMENT	
SUBJECT:	ABS Batteries Software update procedure to version 8.6.3.3.51.11	
ISSUE	Software updates and improvements	
SUMMARY:	<ol style="list-style-type: none">1. Hardware UVLO faults: Reduced nuisance fault by only setting fault if vehicle is requesting Discharge or Charge.2. Speaker MIA faults: Reduced nuisance fault by only setting fault if vehicle is requesting Discharge or Charge.3. Host Quiet MIA: Reduced nuisance fault by only setting fault if vehicle is requesting Discharge or Charge.4. Host Quiet faults: Reduced nuisance fault by only setting fault if vehicle is requesting Discharge or Charge.5. SOHC: improvement to SOHC algorithm. Improvements to SOC were also implemented.6. Pre-charge timeout setting: allows for per-charging onto 7mF X-capacitance bus.7. Current mismatch: returning behavior/functionality back to previous SW version such as 8.6.2.2.51.4 and prior	

ITS61724

THIS ITS DOCUMENT SHOULD BE RETAINED AND REFERRED TO FOR FUTURE MAINTENANCE UNTIL THE NEW FLYER PARTS AND/OR SERVICE MANUAL IS UPDATED TO REFLECT WORK DONE AS A RESULT OF THIS DOCUMENT. ENSURE THAT THIS DOCUMENT IS AVAILABLE FOR PARTS AND MAINTENANCE STAFF GOING FORWARD.



Contents

INSTRUCTION TO SERVICE	1
1. SAFETY PROCEDURE.....	3
2. Scope.....	4
3. Rework – ABS Battery software flashing requirements.....	4
4. Service Diagnostic Interface and Health Check	4
5. Flashing Procedure.....	7
6. Appendix A – Software verification	9



NEW FLYER

⚠ WARNING: Only trained personnel shall supervise and perform High Voltage system testing, checkout and troubleshooting. Two personnel (one called the Checker & the other called Monitor/Recorder) shall perform Checkout Procedures, together, to ensure safety of themselves, others nearby & for the protection of vehicle & property. Refresher training shall be provided to these personnel on a regular basis and when new systems are to be checked by them. The training of the personnel shall consist of:

1. SAFETY PROCEDURE

- 1.1. Turn the master run, switch to the off position and wait 5 minutes before proceeding.
- 1.2. Turn the 12/24V battery disconnect and HV Interlock switch to the "OFF" position.
- 1.3. Lock and tag the electrical system of the bus out and retain the key. See Figure 1.
- 1.4. Install a Lockout/Tagout Steering wheel cover as required.

👉 NOTE: Refer to the Lockout/Tagout Procedure in section 1 of your Preventive Maintenance Manual or section 9 of your Service manual for additional information.

👉 NOTE: Use commercially available lock out equipment and tags being sure to follow any local laws or workplace procedures.

👉 NOTE: Refer to New Flyer High Voltage Safety Guidelines and Procedures Document 532295 when completing installation or service work on high voltage power cables.

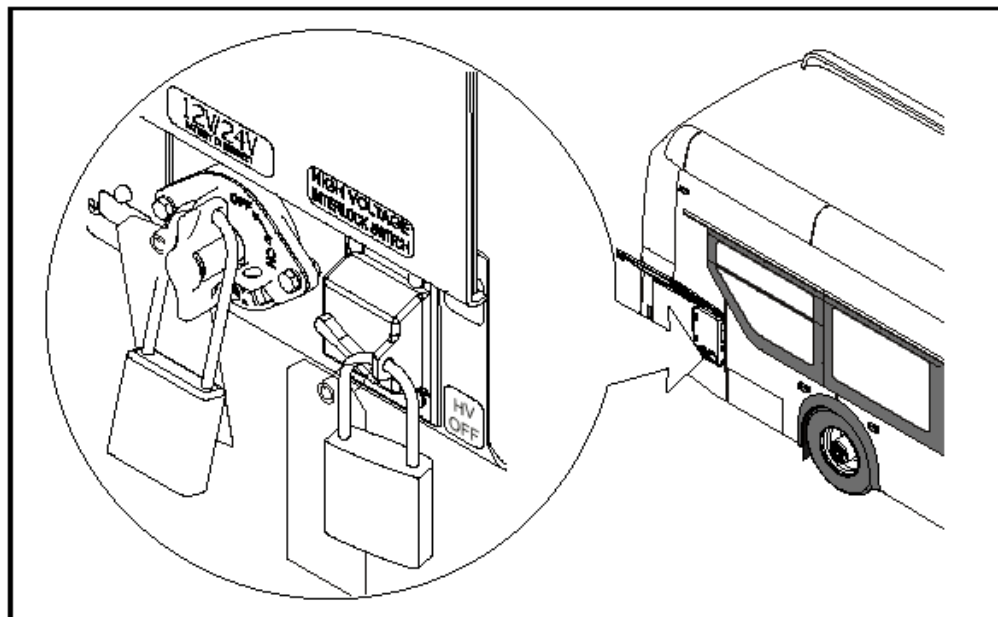

Figure 1- Lockout tagout location reference

2. Scope

The following ITS is applicable to all ABS battery systems and will detail the process for updating bootloader, performing a single binary flash on new and existing systems and performing individual flashing on existing systems.

3. Rework – ABS Battery software flashing requirements.

3.1. Software Needed:

- A. ABS Service Diagnostic Tool v2.1.4 (or newer).

3.2. Tools Needed:

- A. Laptop w/ Peak drivers installed.
- B. A two channel PEAK-CAN Tool w/ 9-Pin diagnostic interface. An alternative option is to use two single channels, PEAK-CAN tool as well.



Figure 2 - PEAK tool

3.3. Battery software verification:

Before performing this procedure, please follow Appendix A to verify that the battery software version matches the current one in the B.O.M. for any assistance, please reach out to the RPSM to enquire about the latest software version information. If no update is needed, please proceed with the flashing procedure.

4. Service Diagnostic Interface and Health Check

- 4.1. Turn MRS ON, **DO NOT** enter EV Mode.
- 4.2. Connect laptop to the EBUS DIAG on Channel 2 using the PEAK CAN Tool.
- 4.3. Open Service Diagnostic Tool v2.1.4 (hereafter will be referred to as SDT).
- 4.4. At the top left, next to "Pack" select the drop down and select "NF"

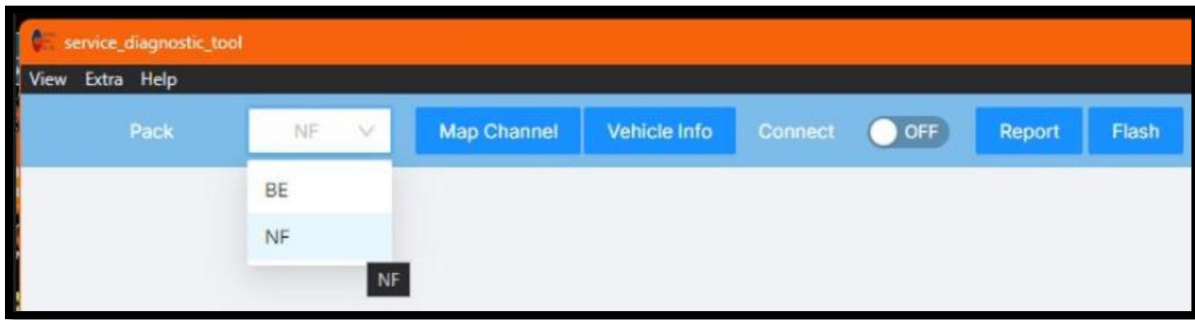

Figure 3 - Service Diag Tool main window

4.5. Click on “Map Channel”, and set System Channel to 1, and Pack Channel to 2.

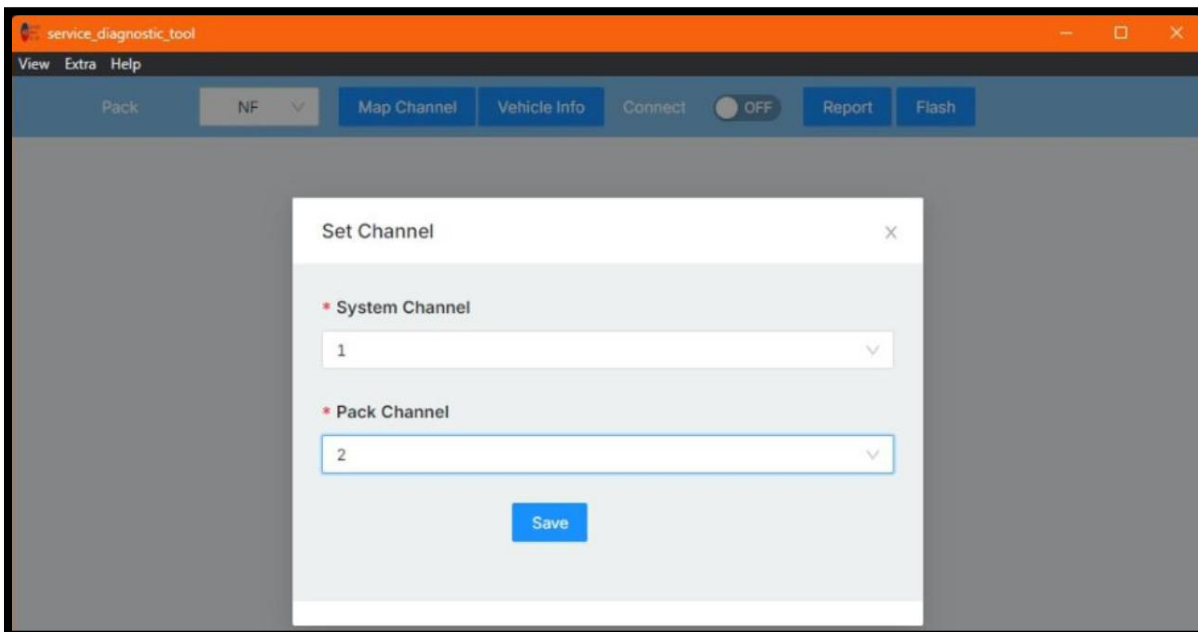

Figure 4 - Service Diag Tool main window

4.6. Click on “Vehicle Info”. Under Vehicle Number, put the bus ID, under Customer Name the SR number, and under Location the production facility, then click “Submit”. See example below:

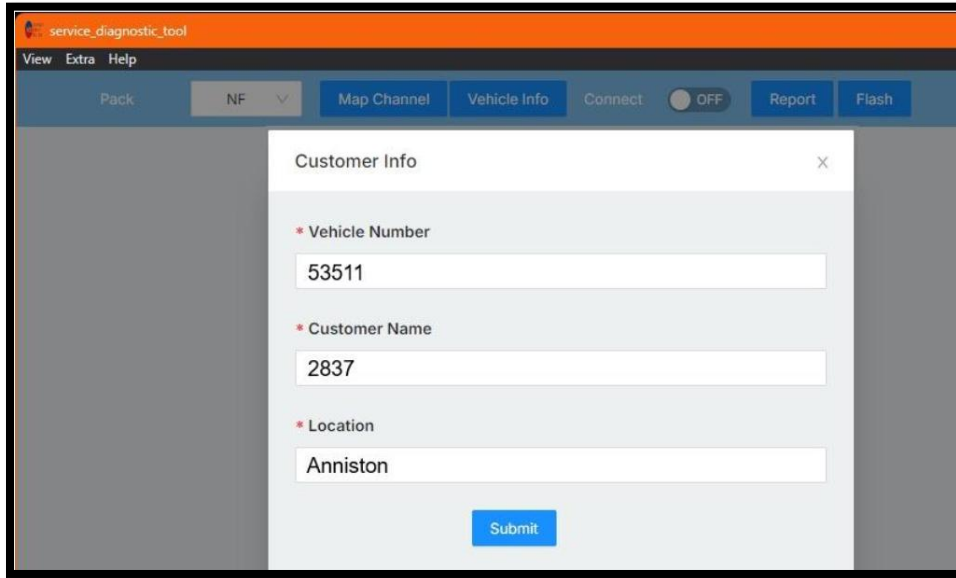

Figure 5 - Service tool – Customer info (Example)

4.7. On the upper ribbon find the “Connect” option and toggle it to the “ON” state.

4.8. The service tool will default to the System Level view, where system and overall pack status can be reviewed. See example below:

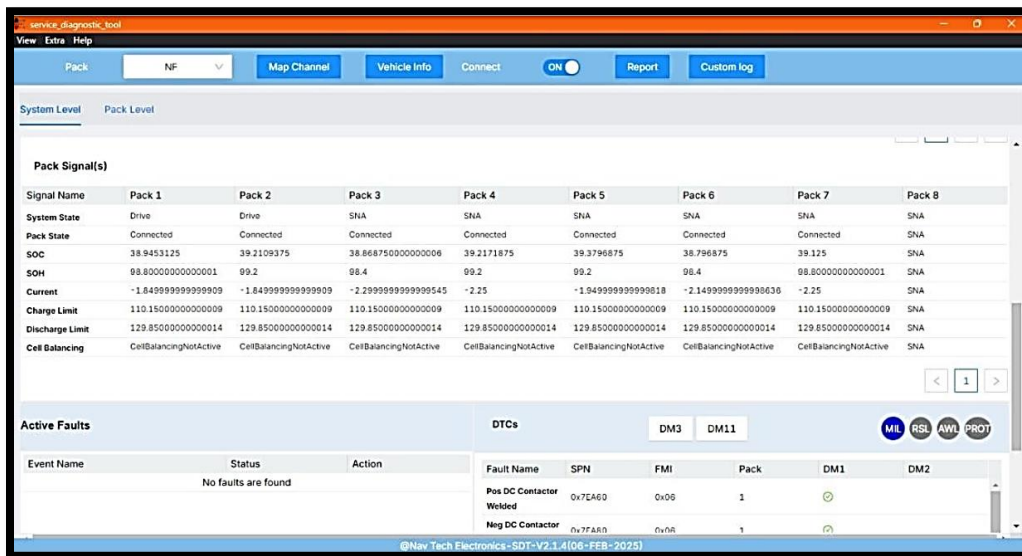

Figure 6 - System Level view

4.9. Verify that all packs (number will vary by contract) are online and healthy, and that there are no active faults or DTCs.



- 4.10. If a DTCs do exist, you can attempt running the “DM3” and “DM11” clear functions. Click the DM3 button, wait 30 seconds, click the DM11 button, wait 30 seconds, cycle the MRS to the OFF position. Make sure all VMM’s power down to sleep. close and reopen the diagnostic software and repeat steps 4.4 - 4.10.
- 4.11. If the issue persists, contact ABS service or NFI engineering support.
- 4.12. Once the vehicle is confirmed to be in a healthy state, toggle the Connect option to “OFF” and begin the flashing process.

5. Flashing Procedure

- 5.1. Reach out to the RPSM to enquire about the latest software version files for the application and calibration.
- 5.2. Turn MRS ON, but **DO NOT** enter EV mode.
- 5.3. Connect laptop to the EBUS DIAG on Channel 2 using a Peak CAN Tool.
- 5.4. Open Service Diagnostic Tool.
- 5.5. In the top right of the ribbon select “Flash”.
- 5.6. Set up the Flashing ECU screen and the relevant pack to be flashed as shown below:

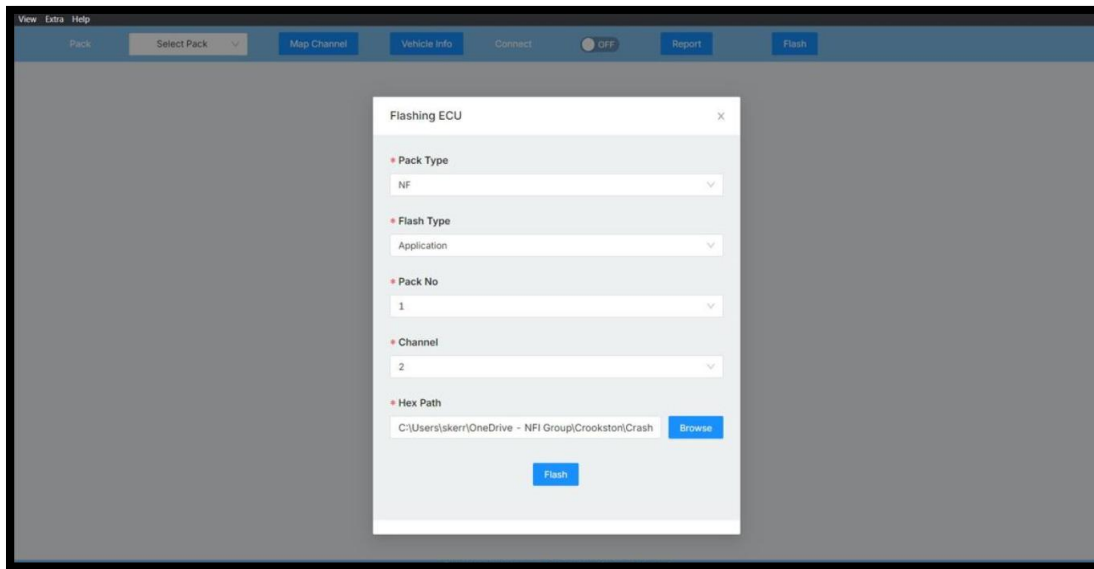

Figure 7 - Flashing ECU

- 5.7. Under “Hex Path” Browse and select the Application file on your computer.
- 5.8. Click “Flash” and then DO NOT click out of this window.

WARNING!

Clicking anywhere else outside of this window during the flashing process will cause the flashing process to abort!

5.9. Once flashing has completed you will see “Flashed done successfully” in green text.

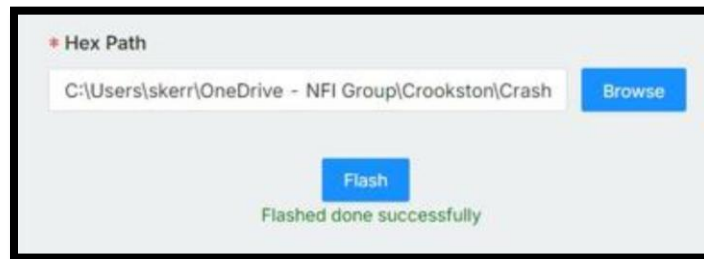

Figure 8 - Flash Done message

5.10. Repeat this process for each Pack (number varies by contract).

5.11. Once the Application file has been loaded to all strings, repeat steps 5.7 through 5.10 for the Calibration file.

5.12. After flashing the Application and Calibration files to all battery strings refer to Appendix A to verify the programs were successfully loaded to all packs.



NEW FLYER

6. Appendix A – Software verification

To verify what software is already loaded to the ABS battery system, perform the following steps:

- 6.1. Connect the PEAK tool to the port on the vehicle that monitors the ESS.
- 6.2. Turn MRS (T15) to the ON position.
- 6.3. Wait approximately 5 minutes, to ensure the ESS has time to fully wake up.
- 6.4. Open the SDT and navigate to the **pack level** screen. Verify that there are no active faults and the correct revision is listed under the “BMS Details” - **v8.6.3.3.51.9. or v8.6.3.3.51.4**

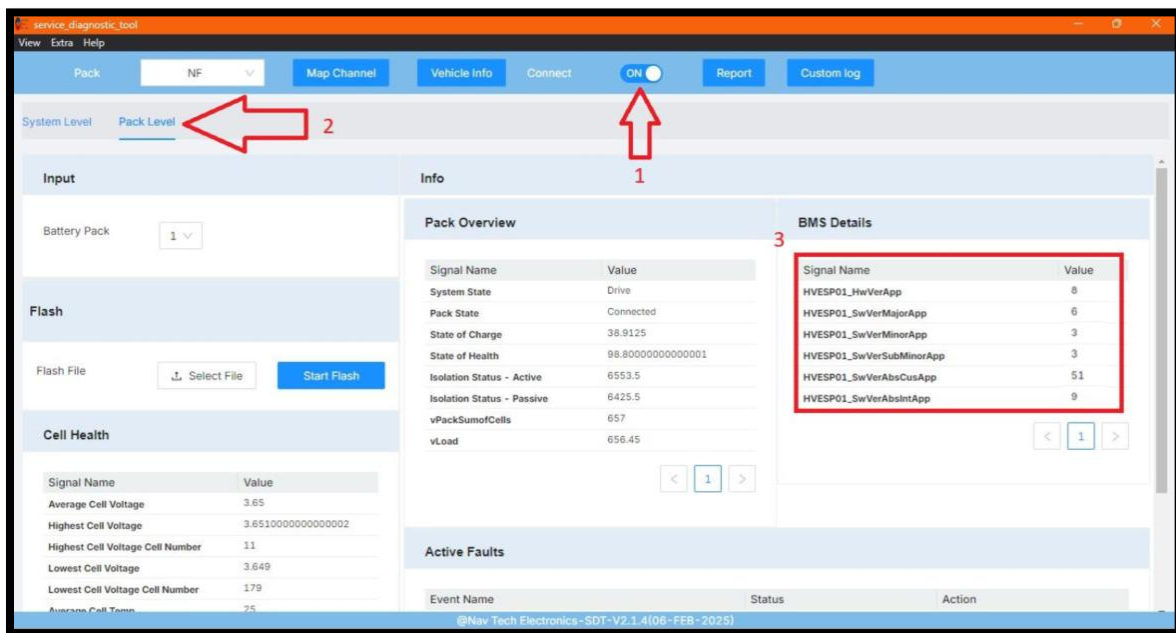

Figure 9 - BMS Details

Verify no active faults



LABOUR ESTIMATE				
	Operation	Number of Technician(s)	Hours	Labor Time T X HR
1	Rework – ABS software flashing	1	1.5	1.5

PARTS REQUIRED					
Item	Part Number	Description	Qty. per Coach	Units	Notes
1	1161965	ADAPTER-PCAN-USB CABLE (IPEH-002021)	2		
2	711447	SIEMENS PCAN INTERFACE CABLE	1		