



# INSTRUCTION TO SERVICE

ITS: 61722		DATE 05/13/2026
<b>SECTION:</b>	304U- Decals	
<b>SUBJECT:</b>	Install New CNG Decal on Rear Bumper	
<b>ISSUE:</b>	Decal Did Not Meet NY Regulations	
<b>SUMMARY:</b>	Install New Decal	

# ITS61722

Ref. NHTSA Recall No.	Ref. Transport Canada Recall No.
Not Applicable	Not Applicable

**THIS ITS DOCUMENT SHOULD BE RETAINED AND REFERRED TO FOR FUTURE MAINTENANCE UNTIL THE NEW FLYER PARTS AND/OR SERVICE MANUAL IS UPDATED TO REFLECT WORK DONE AS A RESULT OF THIS DOCUMENT. ENSURE THAT THIS DOCUMENT IS AVAILABLE FOR PARTS AND MAINTENANCE STAFF GOING FORWARD.**



# NEW FLYER PROCEDURE:

1. Ensure to apply the parking brake.
2. Turn the main battery disconnect switch to the "OFF" position.
3. Please use the instructions and illustrations in Figure 1A for the SRs listed any remaining SRs will use the steps and illustrations on the following page.
4. Gain access to the rear bumper and clean the area shown below with isopropyl alcohol and a dry lint free cloth. (Source alcohol locally) See Figure 1A.
5. Locate and install the new decal item #1 at 2.0 inches in from the outside edge of the bumper and 3.8 inches up from the bottom of the bumper as shown below. See Figure 1A.
6. Clean up any tools and debris and return the bus to service condition.

SR	Op Gr	C/U Side	Item Seq	Action	Installatio...
1517	304	U	6000	Add	EAD-030817
1518	304	U	6000	Add	EAD-030817
1519	304	U	6000	Add	EAD-030817
1689	304	U	6000	Add	EAD-030817
1715	304	U	6001	Add	EAD-030817

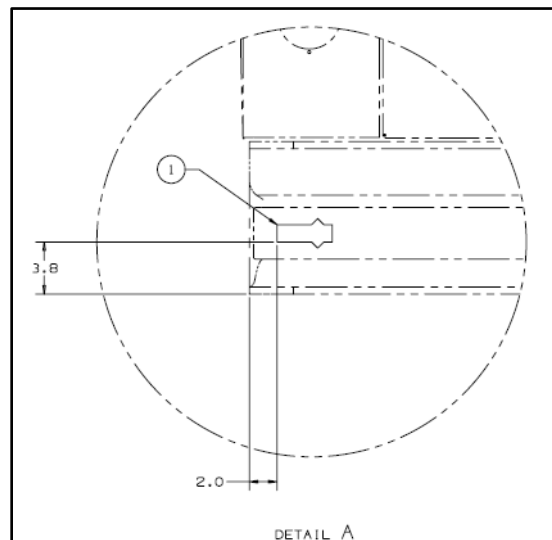
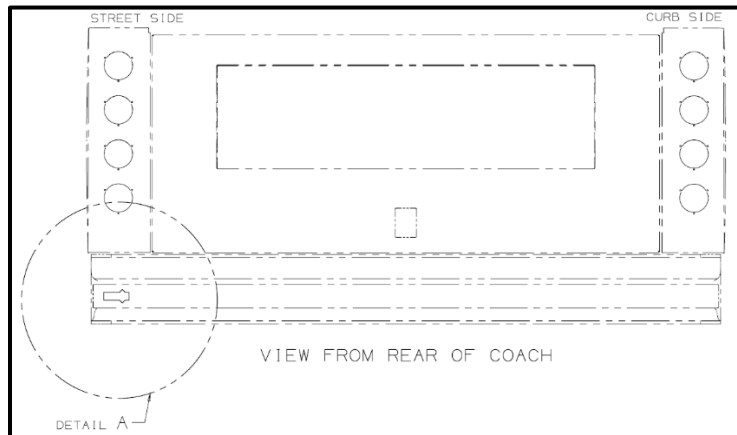

Figure 1A: Rear bumper CNG decal installation location reference.



**NEW FLYER**

7. Gain access to the rear bumper and clean the area shown below with isopropyl alcohol and a dry lint free cloth. (Source alcohol locally) See Figure 1B.
8. Locate and install the new decal item #1 at 5.0 inches down from the top edge of the bumper and 6.8 inches from the bumper seam as shown below. See Figure 1B.
9. Clean up any tools and debris and return the bus to service condition.

SR	Op Gr	C/U Side	Item Seq	Action	Installatio...
2041	304	U	6001	Add	EAD-030813
2056	304	U	6001	Add	EAD-030813
2082	304	U	6001	Add	EAD-030813
2114	304	U	6002	Add	EAD-030813
2115	304	U	6001	Add	EAD-030813
2162	304	U	6001	Add	EAD-030813
2181	304	U	6002	Add	EAD-030813
2077	304	U	6001	Add	EAD-030813
2400	304	U	6000	Add	EAD-030813
2059	304	U	6001	Add	EAD-030813
1945	304	U	6000	Add	EAD-030813
2510	304	U	6001	Add	EAD-030813

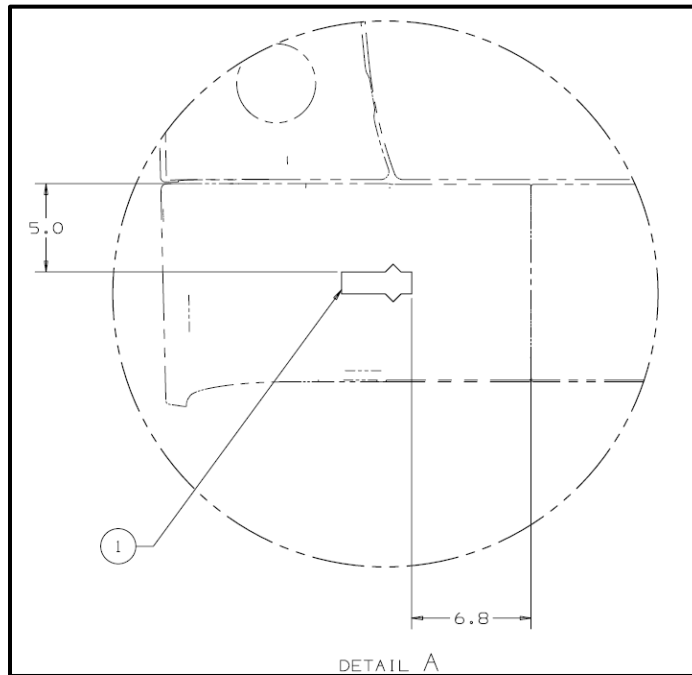
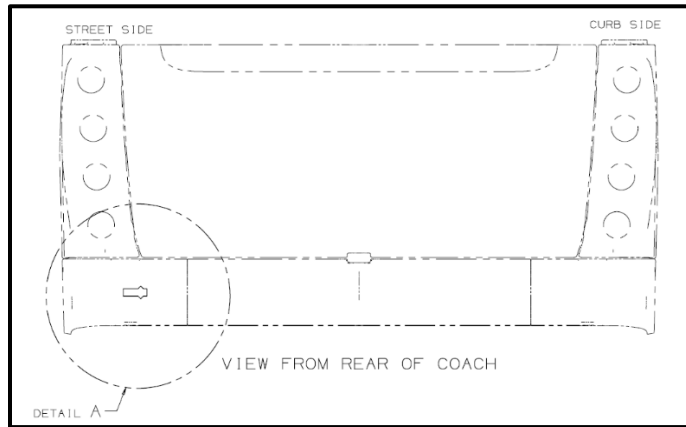

**Figure 1B: Rear bumper CNG decal installation location reference.**



<b>LABOUR ESTIMATE</b>				
	Operation	Number of Technician(s)	Hours	Labor Time T X HR
1	Install New Decal	1	.25	.25

<b>PARTS REQUIRED</b>					
Item	Part Number	Description	Qty. per Coach	Units	Notes
1	1167845	Decal CNG Vehicle Warning	1	EA	

<b>SPECIAL TOOLS REQUIRED</b>					
Item	Part Number	Description	Qty.	Units	Notes
1		NO SPECIAL TOOLS REQUIRED			