

**Volvo Car USA LLC**
**Technical Journal**

|   |   |                                 |                              |
|---|---|---------------------------------|------------------------------|
| Technical Journal Title<br><b>Prior Approval: Check Engine Light with Camshaft or VVT Pulley DTCs</b> |   | Ref. No.<br><b>TJ 37618.3.0</b> |                              |
| Issuer (Dept.)<br><b>Technical Service</b>  |   | Issue Date<br><b>4/1/26</b>     | Status Date<br><b>4/3/26</b> |
| Car Market<br><b>United States and Canada</b>   | Partner<br><b>3 US 7510 Volvo Car USA</b> | Function Group<br><b>2154</b>   |                              |
| Function Description<br><b>Camshaft</b>   |   | Page<br><b>Page 1 of 134</b>    |                              |

**Attachment**

| File Name                  | File Size |
|----------------------------|-----------|
| TJI-531608-1_1_5_en-US.pdf | 3.6219 MB |
| TJI-531608-2_1_5_en-US.pdf | 3.3553 MB |
| TJ_37618_1.pdf             | 0.6309 MB |
| TJ_37618_2.pdf             | 0.2175 MB |

Rows beginning with \* are modified

Note! If using a printed copy of this Technical Journal, first check for the latest online version.

**DESCRIPTION:**

\*Instructions added to "Service".

\*Attachment added.

If the Check Engine Light is on in the DIM and one or more of the DTCs listed below are set, please follow the advice under "Service".

**CSC** Customer Symptom Codes

| Code | Description   |
|------|---|
| DL   | Warning lights and chimes/Malfunction Indicator Light ("Check engine" light) indication/no indication |

**DTC** Diagnostic Trouble Codes

| Control Module | Code    | Fault Type |
|----------------|---------|------------|
| ECM            | P036692 | Permanent  |
| ECM            | P061C48 | Permanent  |
| ECM            | P001500 | Permanent  |
| ECM            | P001400 | Permanent  |
| ECM            | P001200 | Permanent  |
| ECM            | P001100 | Permanent  |
| ECM            | P001792 | Permanent  |
| ECM            | P001721 | Permanent  |
| ECM            | P034100 | Permanent  |

## Technical Journal 37618.3.0

---

### Vehicle Type

| Type | Eng | Eng Desc | Sales | Body | Gear | Steer | Model Year | Plant | Chassis range | Struc Week Range |
|------|-----|----------|-------|------|------|-------|------------|-------|---------------|------------------|
| 224  | L1  | BL1KERS  |       |      |      |       | 2022-2025  | 70    | -             | 202122-202425    |
| 225  | 06  | B06KERS  |       |      |      |       | 2023-2023  | 21    | -             | 202017-202313    |
| 225  | 06  | B06KERS  |       |      |      |       | 2023-2023  | 22    | -             | 202222-202316    |
| 227  | L1  | BL1KERS  |       |      |      |       | 2023-2024  | 21    | -             | 202217-202416    |
| 227  | L1  | BL1KERS  |       |      |      |       | 2023-2026  | 22    | -             | 202222-202517    |
| 236  | 06  | B06KERS  |       |      |      |       | 2022-2026  | 21    | -             | 202122-202543    |
| 238  | 06  | B06KERS  |       |      |      |       | 2022-2025  | 35    | -             | 202122-202516    |
| 238  | L1  | BL1KERS  |       |      |      |       | 2026-2026  | 35    | -             | 202517-202533    |
| 246  | 06  | B06KERS  |       |      |      |       | 2022-2023  | 21    | -             | 202122-202316    |
| 246  | 06  | B06KERS  |       |      |      |       | 2022-2023  | 36    | -             | 202122-202316    |
| 246  | L1  | BL1KERS  |       |      |      |       | 2022-2024  | 21    | -             | 202122-202317    |
| 246  | L1  | BL1KERS  |       |      |      |       | 2022-2024  | 36    | -             | 202122-202416    |
| 246  | M1  | BM1KERS  |       |      |      |       | 2025-2026  | 21    | -             | 202416-202543    |
| 246  | M1  | BM1KERS  |       |      |      |       | 2025-2025  | 36    | -             | 202417-202516    |
| 256  | 06  | B06KERS  |       |      |      |       | 2023-2026  | 21    | -             | 202222-202543    |
| 256  | L1  | BL1KERS  |       |      |      |       | 2023-2024  | 21    | -             | 202217-202416    |
| 256  | M1  | BM1KERS  |       |      |      |       | 2025-2026  | 21    | -             | 202407-202543    |
| 536  | K9  | BK9KERS  |       |      |      |       | 2023-2026  | 22    | -             | 202222-202343    |
| 536  | L1  | BL1KERS  |       |      |      |       | 2023-2026  | 22    | -             | 202222-202543    |

### SERVICE:

**\*Important! If DTC P034100 is the only DTC set, verify whether it was set below 825 RPM (reference attachment TJ\_37618\_1).**

**\*If the DTC was set below 825 RPM, do not replace any parts. A new ECM SW for DTC P034100 will be released in 2026 week 18.**

**\*If DTC P034100 was set at a higher RPM, or if other DTCs are set (either alone or in combination), follow the instructions below.**

**If the Check Engine Light is on in the DIM and one or more of the DTCs listed in this journal are stored, please follow the steps below.**

1. Perform a new (not existing) VIDA readout.
2. Run the VIDA script "Component Test: VVT Unit" or "Component Test: Check VVT" (Found in CSC fault tracing using Function "Powertrain: Driving" and Symptom "DL Check Engine Light") and save the results in a .plot file.
3. Contact Retailer Technical Support by creating a TIE report with Concern area **"Vehicle Report"** and the sub-concern area **"Prior Approval"**.

### Details to include in the report:

- How many times has the vehicle been at a workshop for this issue, and what repairs or parts replacements have been done.
- Plot files from VIDA showing the results of the VVT component tests.
- The service history of the vehicle.
- What were the conditions when the Check Engine Light came on? (first start of the day, after driving for XX miles, when accelerating, etc.)

**Note:** The attachments in this journal are only to be used after receiving prior approval from Retailer Technical Support (RTS).

**Note:** If replacing camshafts or camshafts and VVT pulleys per RTS guidance, follow the repair instructions attached to this TJ rather than the instructions in VIDA. (TJI-531608-1\_1\_5\_en-US 1.pdf for SPA1, TJI-531608-2\_1\_5\_en-US 1.pdf for CMA.

**Note:** If replacing VVT pulleys only per RTS guidance, follow the VIDA repair instructions with the exception of replacing the timing belt kit. The timing belt kit should be reused unless it has been subjected to abnormal mechanical stress, damage, or oil contamination.

**Note:** When setting the timing with a used timing belt, the technician should reference VIDA > Information > Repair > Cleaning, Inspection, and Adjustment > 215 Timing belt, service position.

**Note:** Only hand tools should be used for repairs according to the VIDA methods; otherwise, parts may be damaged.

### Abbreviations:

DIM: Driver Information Module

ECM: Engine Control Module

CSC: Customer Symptom Code

RTS: Retailer Technical Support

### Warranty claim info:

To get a warranty claim accepted for a job described in this TJ, use the corresponding VST OP number stated in this TJ.

Please note that fault tracing is not eligible for separate reimbursement under this TJ. Any fault tracing VST operation numbers will be rejected.

Note that the TJ number must be stated in the repair order text.

**\*Note: If RTS advises replacing VVT Pulleys only, labor operation 21557-2 “Variable Valve timing unit replace” should be claimed.**

## Technical Journal 37618.3.0

---

### VST Operation Number

| VST Operation Number | Description   |
|----------------------|---|
| 98817-2              | DTC readout/ reset incl. VIDA connection acc. to TJ |
| 98783-2              | Camshaft sleeve acc.to TJ.                          |
| 98802-2              | General Reimbursement acc to TJ                     |
| 98821-3              | Software download acc. to TJ                        |
| 36100-2              | Test drive according to Technical Journal 4JV       |

### VEHICLE REPORT:

Yes, please submit a Vehicle Report if the service solution described in this TJ has no effect. Use the concern area "Vehicle Report" and the sub-concern area "Prior Approval", use function group 2154.

**To view TJ attachments continue to next page. This TJ has two attachments.**

Home S90L, 2025, B420T11, AWPB/G48... x Rainer Bordt - Volvo Car Corporation Dept. 57324

Planning & Diagnostics Software Installation Information Service Journals 🔍 📄 🔄 🏠

 VIN: LVYPM1D0SP444218 🔌 14 V / 91% 🚗 Driving List: --- 🔌 Disconnect

Model/Year/Chassis: S90L, 2025, 444218 Readout (Latest) 17/02/2026 09:41:26 🇩🇪

**Lists**

- Planning
- Customer Symptom Codes
- Claim Types
- Technical Journals
- Service Programs
- Operations and Packages
- Parts
- Software
- **Diagnostics**
- Components
- Service Functions
- Events

ECUs: **Sensors & Actuators** | Cable harnesses | Connectors 📄 🔄

| ID    | Name                                       |
|-------|--|
| 4184  | Active Safety Domain Master (ASDM)         |
| 16105 | Audio Control Module (AJD)                 |
| 417   | Brake Control Module 2 (BCM2)              |
| 16202 | Center Console Display (CCD)               |
| 456   | Central Electronic Module (CEM)            |
| 4154  | Climate Control Module (CCM)               |
| 4213  | Driver Door Module (DDM), Default          |
| 51    | Driver Information Module (DIM)            |
| 4197  | Electronic Gear Selector Module (EGSM)     |
| 446   | Engine Control Module (ECM)                |
| 4318  | Forward-Looking Camera 2 (FLC2)            |
| 4291  | Forward-Looking Radar (FLR)                |
| 4112  | Headlamp Control Module Left (HCL)         |
| 4113  | Headlamp Control Module Right (HCLR)       |
| 4185  | Infotainment Head Unit (IHU)               |
| 4263  | Integrated Starter Generator Module (ISGM) |
| 4270  | Mid-Voltage Battery Module (MVB)           |
| 4265  | Mid-Voltage Converter Module (MVC)         |
| 4198  | Overhead Console (OHC)                     |
| 4214  | Passenger Door Module (PDM), Default       |
| 4169  | Power Seat Module Driver (PSMD)            |
| 4210  | Power Seat Module Passenger (PSMP)         |

DTCs: Documents | Wiring Diagrams | Parameters | Activations | Diagnostic Sequences | Images | ECU Identification 🔍 📄

**Confirmed** | **All DTCs** Status

🔌 ECM-P034100 Camshaft Position Sensor "A" Circuit Range/Performance (Bank 1 or single sensor) 1.

Read DTCs | Erase All

Client Version: 26.1.3.267 🔌 IT Requirement | 📄 help

TJ\_37618

DTC Extended Information

Overview Details **2.**

**ECM-P034100 Camshaft Position Sensor "A" Circuit Range/Performance (Bank 1 or single sensor).**

**Information**

The camshaft position sensor is used by the Engine Control Module (ECM) to determine the camshaft's position. The camshaft position sensor uses a pulse wheel on the camshaft consisting of five teeth to detect the flanks.

**Test run criteria**

The control module's test for the DTC starts when:

- The vehicle is in usage mode driving.

**Detection criteria**

The DTC is set if the control module detects that:

- One or more pulses are missing during a revolution.

**Fault handling in the control module**

- The Engine Control Module (ECM) uses the crankshaft position sensor signal.
- The Engine Control Module (ECM) does not use the VVT-unit.

TJ\_37618

### V O L V O

DTC Extended Information

[Overview](#) [Details](#)

**ECM-P034100 Camshaft Position Sensor "A" Circuit Range/Performance (Bank 1 or single sensor).** [Graph view](#) [Data view](#)

**Timeline**

Last  
 17/02/2026 09:28:06  
First Now  
 17/02/2026 09:28:06 | 17/02/2026 09:41:25  
Frozen values  
 17/02/2026 09:28:06

| Test Run  |            |             | Test Result       |     |            |             | Calibration       |       |
|-----------|------------|-------------|-------------------|-----|------------|-------------|-------------------|-------|
| Name      | This cycle | Since erase | Name              | Now | This cycle | Since erase | Name              | Value |
| Completed | Yes ✓      | Yes ✓       | Warning indicator | N/A | N/A        | No          | Confirmed limit   | 0 EOC |
| Started   | Yes ✓      | N/A         | Symptom           | N/A | N/A        | No          | Failed inhibited  | False |
|           |            |             | Confirmed         | No  | N/A        | N/A         | Unconfirmed limit | 0     |
|           |            |             | Pending           | Yes | N/A        | N/A         | Aged limit        | 0 EOC |
|           |            |             | Failed            | No  | Yes        | Yes         | Step up           | 0     |
|           |            |             | Unconfirmed       | No  | Yes        | Yes         | Step down         | 0     |

**Fault Counter**

Failed +127

0

Unconfirmed 0

Passed -128

0 5 10 15 20 25 30 35 40 45 50 55 60

[Start](#)

3.

# TJ\_37618

## Technical Journal 37618.3.0

V O L V O

DTC Extended Information

Overview **Details**

**ECM-P034100 Camshaft Position Sensor "A" Circuit Range/Performance (Bank 1 or single sensor)** Graph view Data view

DTC first occurrence 17/02/2026 09:28:06 DTC last occurrence 17/02/2026 09:28:06

| Frozen values                       |                         | Value                  |
|-------------------------------------|-------------------------|------------------------|
| <input type="checkbox"/>            | Intake air pressure     | 34 kPa                 |
| <input checked="" type="checkbox"/> | Engine speed            | 756,25 r/min <b>4.</b> |
| <input checked="" type="checkbox"/> | Vehicle speed (via CAN) | 0 km/h                 |
| <input checked="" type="checkbox"/> | Ignition angle          | 4 CA                   |
| <input checked="" type="checkbox"/> | Intake air temperature  | 29 °C                  |
| <input checked="" type="checkbox"/> | Air mass                | 2,93 g/s               |

| ID   | ECU operation cycle counters   | Value |
|------|--|-------|
| OCC1 | All cycles since last cycle with faults  | 0     |
| OCC2 | Confirmed fault free cycles since last cycle with faults                             | 0     |
| OCC3 | All cycles since first cycle with faults   | 0     |
| OCC4 | All cycles with faults   | 1     |
| OCC5 | OBD cycles since "Check Engine" lamp off   | 0     |
| OCC6 | Consecutive cycles with faults   | 1     |
| OCC7 | Confirmed fault free cycles since first cycle with faults and all cycles with faults | 0     |

| ID  | Status bits               | Value |
|-----|---------------------------|-------|
| SB0 | Failed now                | No    |
| SB1 | Failed this cycle         | Yes   |
| SB2 | Pending                   | Yes   |
| SB3 | Confirmed                 | No    |
| SB4 | Not completed since erase | No    |
| SB5 | Failed since erase        | Yes   |
| SB6 | Not completed this cycle  | No    |
| SB7 | Warning indicator now     | No    |

| ID  | Status indicators             | Value |
|-----|-------------------------------|-------|
| SI0 | Unconfirmed now               | No    |
| SI1 | Unconfirmed this cycle        | Yes   |
| SI2 | Unconfirmed since erase       | Yes   |
| SI3 | Aged DTC                      | No    |
| SI4 | Symptom since erase           | No    |
| SI5 | Warning indicator since erase | No    |
| SI6 | Emission related DTC          | Yes   |
| SI7 | Failed since aging or erase   | Yes   |

| ID    | Fault counters                 | Value |
|-------|--------------------------------|-------|
| FDC10 | Fault counter, current value   | -128  |
| FDC12 | Fault counter, max since erase | 127   |

| ID   | Timestamps      | Value      |
|------|-----------------|------------|
| TS20 | Timestamp first | 10863123,5 |
| TS21 | Timestamp last  | 10863123,5 |

TJ\_37618

**V O L V O**

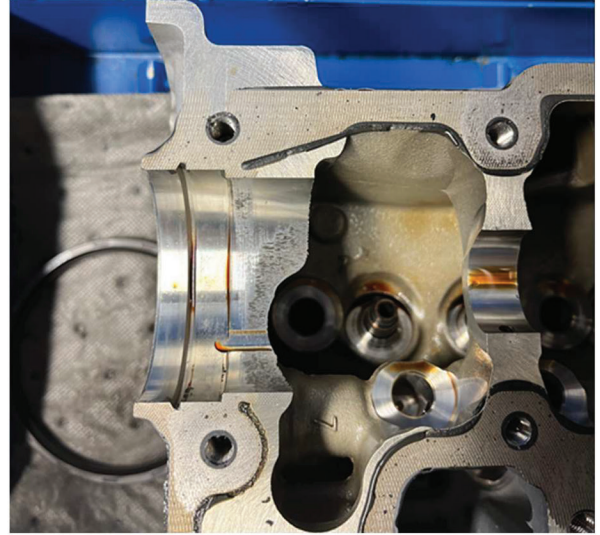
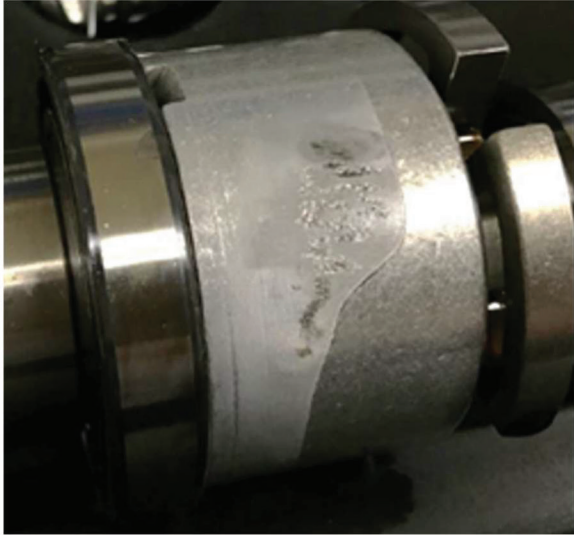

TJ\_37618



## Volvo Car Customer Service

TJ Instruction VCC-531608-1

|               |                  |                          |          |
|---------------|------------------|--------------------------|----------|
| <b>Title</b>  | Camshaft bushing | <b>Page</b>              | 1 ( 65 ) |
| <b>Action</b> | Replacement      | <b>Operation number:</b> | 98783-2  |

| Issue | Date    | Reason                      |
|-------|---------|-----------------------------|
| 3     | 2025-11 | Change in Affected Vehicles |
| 2     | 2025-06 | Change in Affected Vehicles |
| 1     | 2025-03 | First issue                 |

### Affected vehicles

| Model year                               | Model                      | Engine                                 |
|--|----------------------------|--|
| 2021, 2022,<br>2023, 2024,<br>2025, 2026 | S60 (19-)                  | B420T, T10, T11, T2,<br>T3, T4, T5, T6 |
| 2021, 2022,<br>2023, 2024                | S90 (17-)                  | B420T, T10, T2, T6                     |
| 2021, 2022,<br>2023, 2024,<br>2025, 2026 | S90L                       | B420T, T11, T2, T6                     |
| 2021, 2022,<br>2023, 2024,<br>2025, 2026 | V60 (19-)                  | B420T, T10, T2, T3, T4,<br>T5, T6      |
| 2021, 2022,<br>2023, 2024,<br>2025, 2026 | V60 Cross Country<br>(19-) | B420T10, T2                            |
| 2021, 2022,<br>2023, 2024,<br>2025, 2026 | V90 Cross Country          | B420T, T10, T2                         |
| 2021, 2022,<br>2023, 2024,<br>2025, 2026 | XC60 (18-)                 | B420T, T10, T11, T2, T6                |
| 2021, 2022,<br>2023, 2024,<br>2025, 2026 | XC90 (16-)                 | B420T, T10, T11, T2                    |

### Materials

| Materials       | Qty. | Part No. | Notes |
|-----------------|------|----------|-------|
| Isopropanol     | 0.02 |          |       |
| Engine oil      | 0.02 |          |       |
| Chemical gasket | 0.1  | 1161771  |       |

### Special tools

| Description         | Part No. |
|---------------------|----------|
| RADIATOR PROTECTION | 999 5474 |

**Special tools**

| <b>Description</b> | <b>Part No.</b> |
|--------------------|-----------------|
| Mounting           | 999 7534        |
| Support            | 999 7533        |
| Counterhold        | 999 7718        |
| Hook wrench        | 981 4129        |
| L-hook             | 951 2943        |
| Cleaning tool      | 999 7505        |

**Equipment**

| <b>Designation</b>    | <b>Part No.</b> |
|-----------------------|-----------------|
| Interior trim remover |                 |
| Marker pen            |                 |
| Screw M10 x 20 mm     |                 |
| Putty knife (plastic) |                 |
| Abrasive cloth        |                 |

## Removal

**Note! Removal steps in this procedure may contain installation details.**

Illustrations in the information may be reused from previous models and may therefore deviate as regards the background's motif. The technical content relevant to the operation is, however, always correct.

## Color symbols

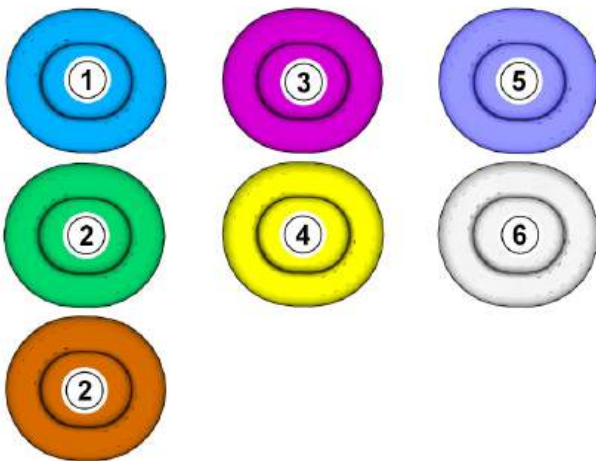

**Note! This colour chart displays (in colour print and electronic version) the importance of the different colours used in the images of the method steps.**

- 1 . Used for focused component, the component with which you will do something.
- 2 . Used as extra colors when you need to show or differentiate additional parts.
- 3 . Used for attachments that are to be removed/installed. May be screws, clips, connectors, etc.
- 4 . Used when the component is not fully removed from the vehicle but only hung to the side.
- 5 . Used for standard tools and special tools.
- 6 . Used as background color for vehicle components.

See information on safety information fuel system , refer to:

- General Safety Information
- 2 - Engine with mountings and equipment
- 23 - Fuel system
- 230 - general



**Note! Orientation view**

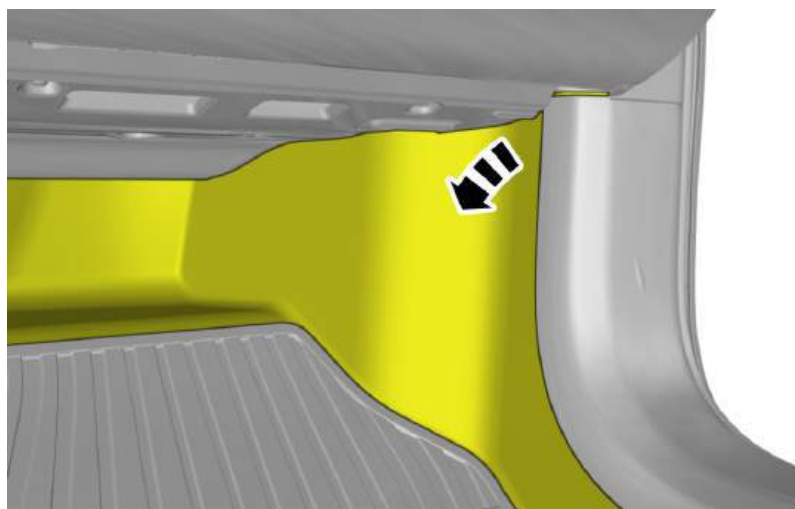

Fold the carpet aside.

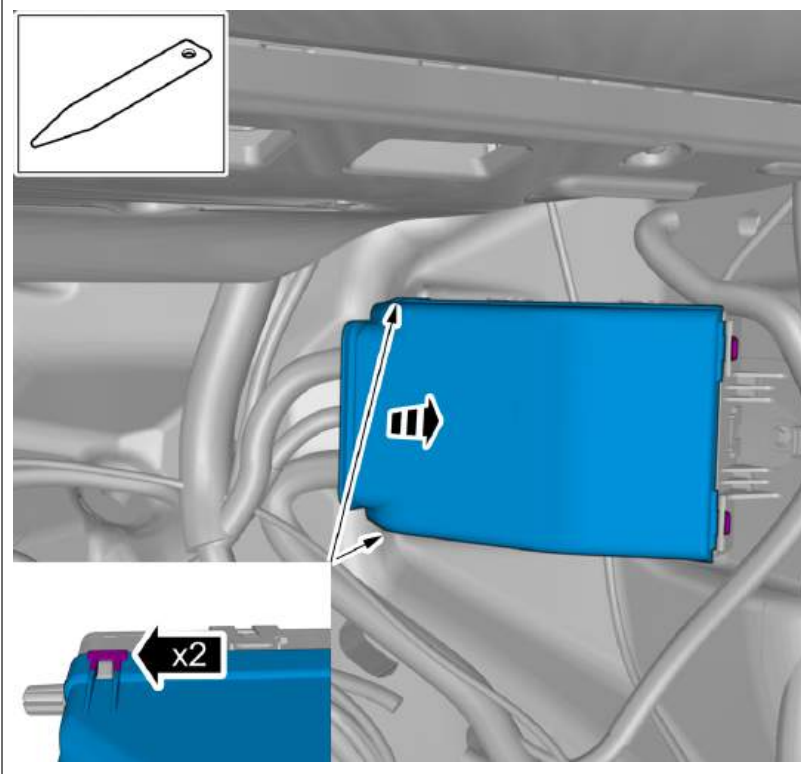

Remove the marked part.

**Use:** Interior trim remover

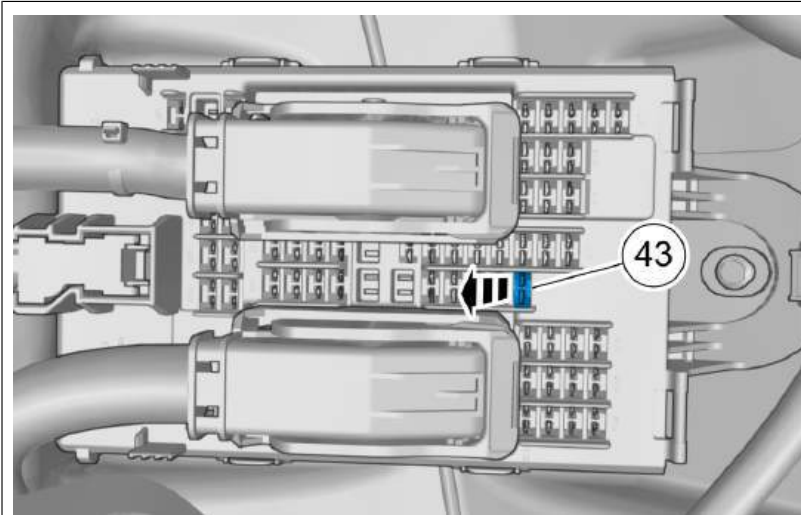

Remove the fuse for the fuel pump (FP).



Start and run the engine at idle until it stops.

### Disconnecting the battery

Disconnect mid voltage battery, disconnecting and connecting , refer to:

Cleaning, Inspection and Adjustment

3 - Electrical system

31 - Battery and mounting

311 - battery

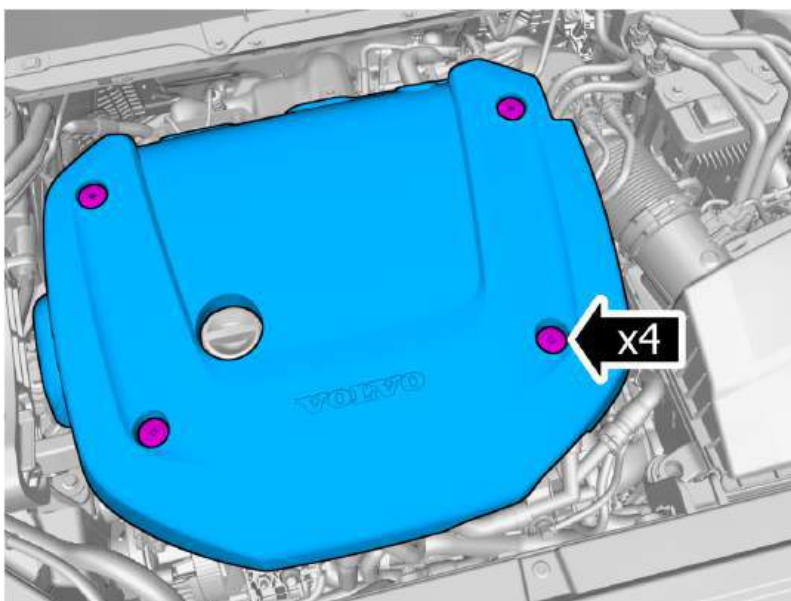

Loosen the screws.

Remove the marked part.

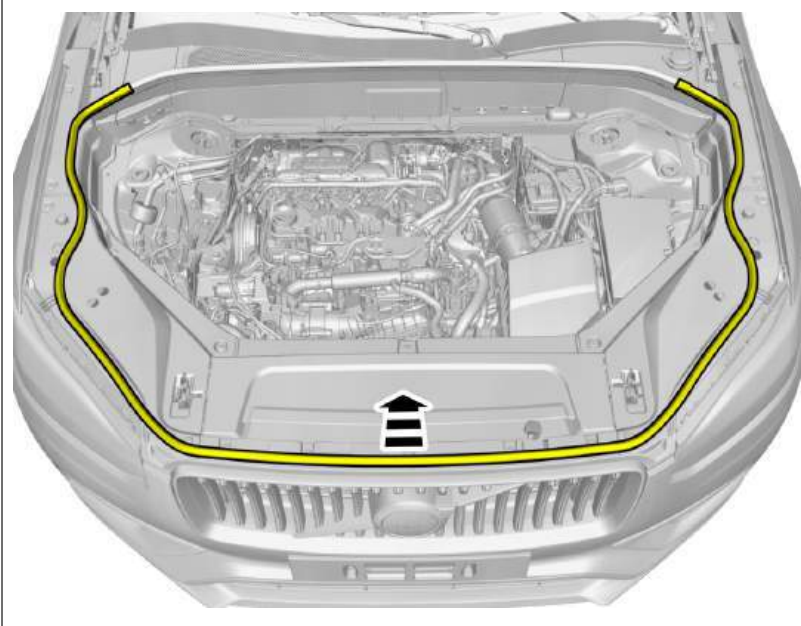

Fold marked part aside.

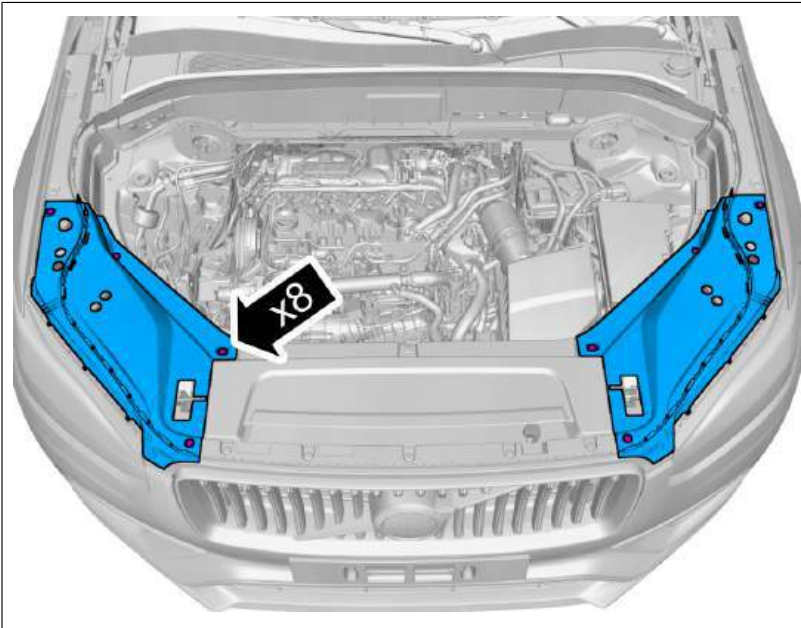

Remove the clips.  
Remove the marked parts.

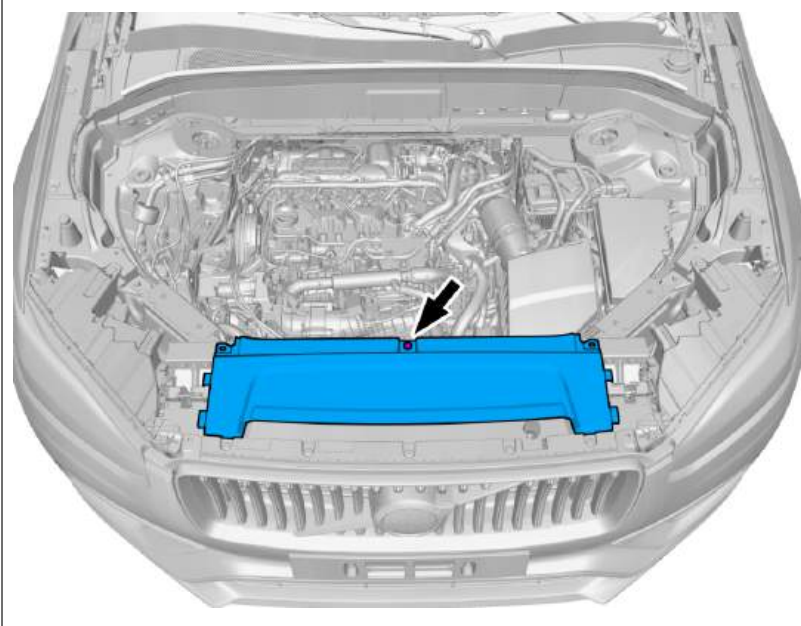

Remove the clip.  
Remove the marked part.

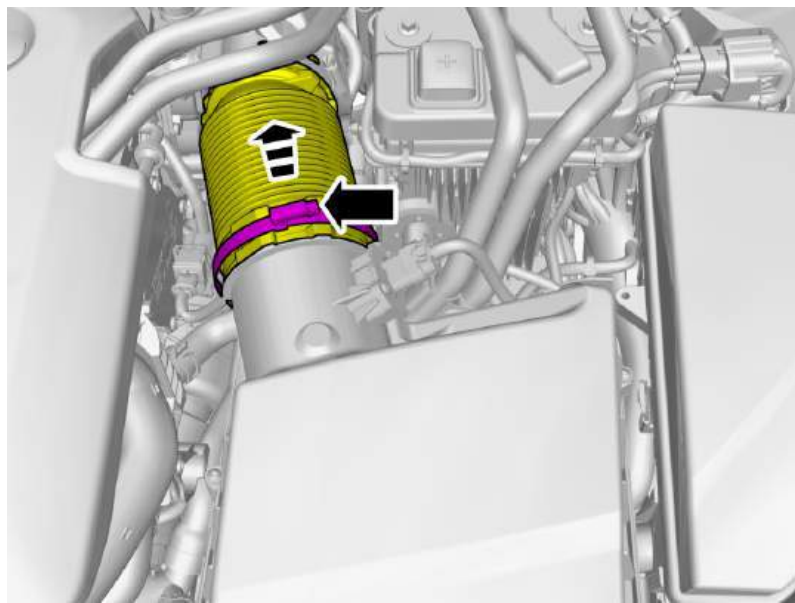

Loosen the hose clamp.  
Undo the hose from the connection.

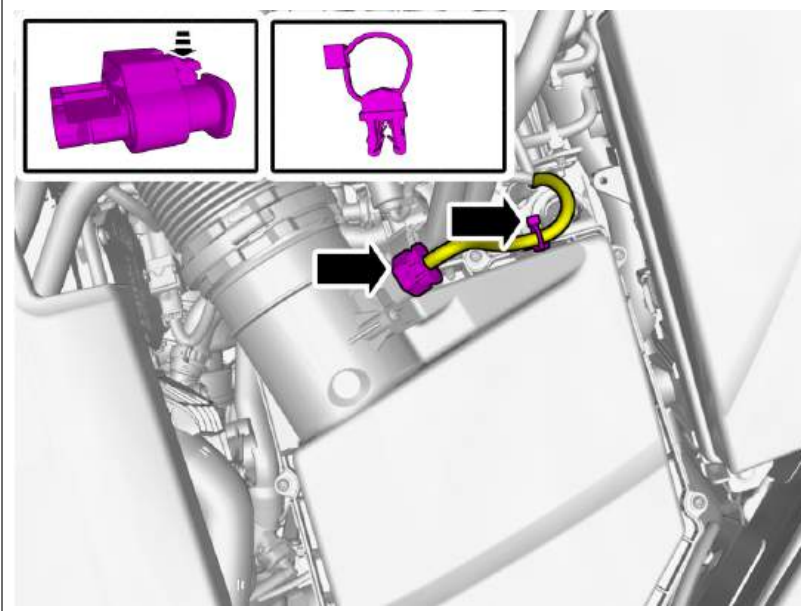

Disconnect the connector.  
Remove the cable harness clips.

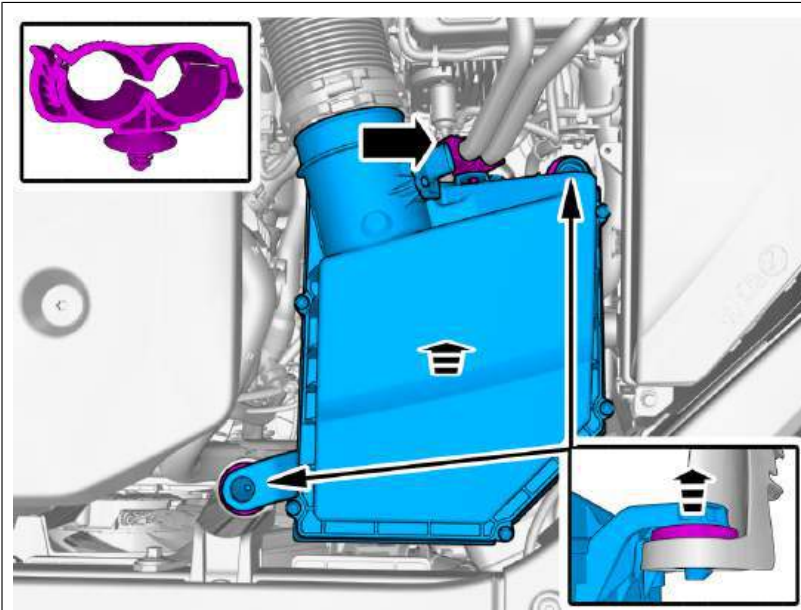

Loosen the clip.  
Lift the marked component up

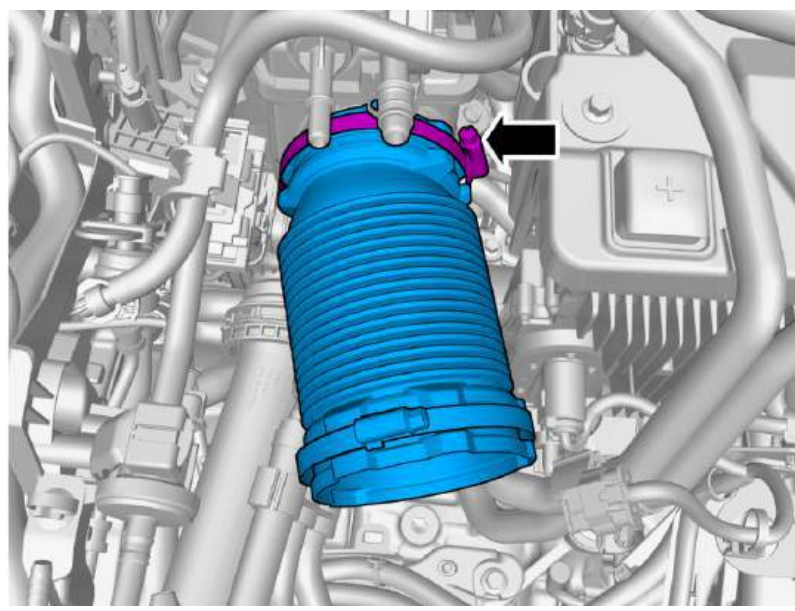

Loosen the hose clamp.  
Remove the marked part.

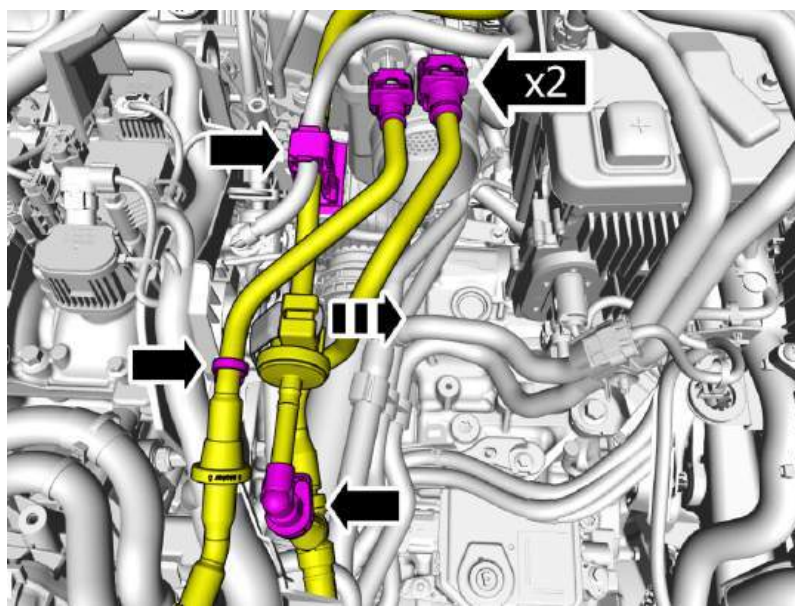

Remove the clips.  
Release the locks.  
Undo the hoses from the connections.  
Fold marked parts aside.

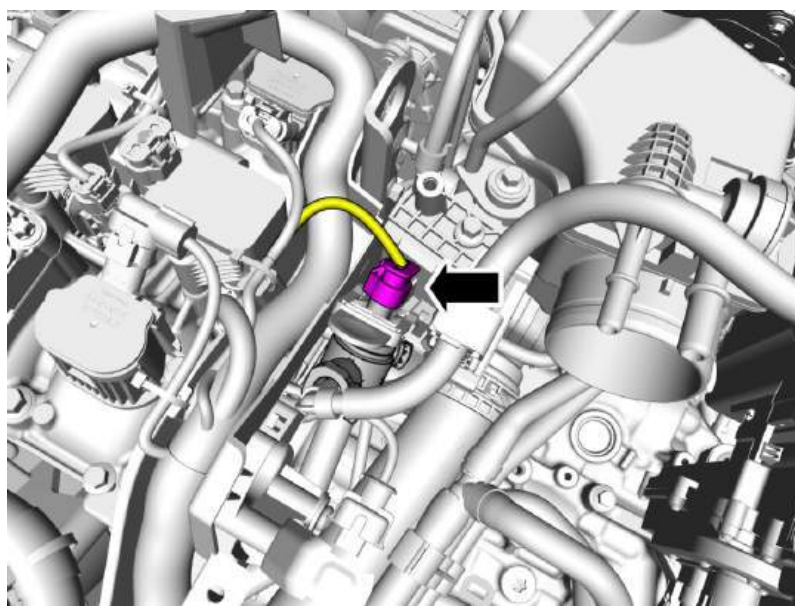

Disconnect the connector.

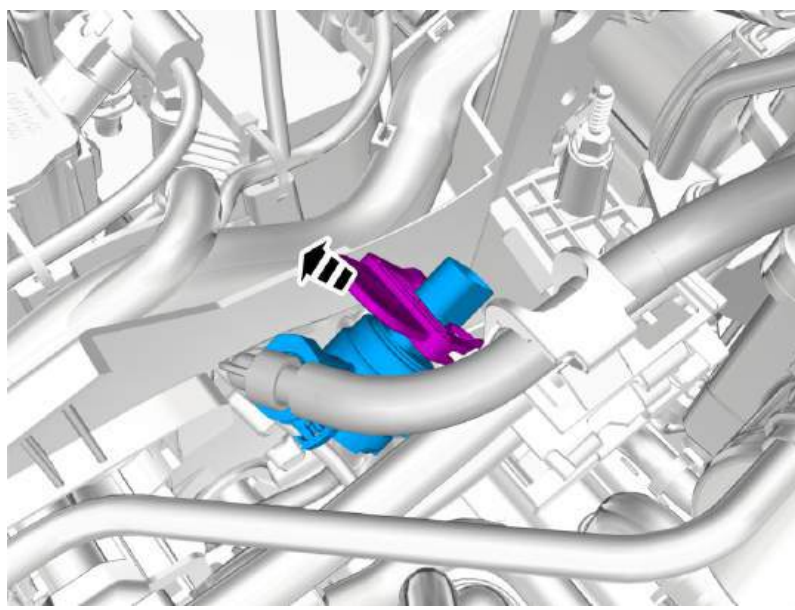

Loosen the clip.

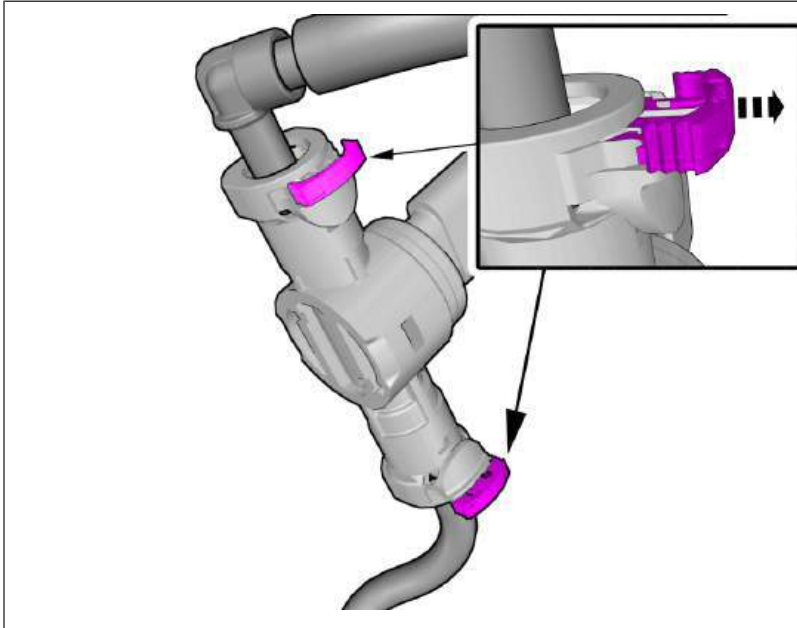

Release the locks.

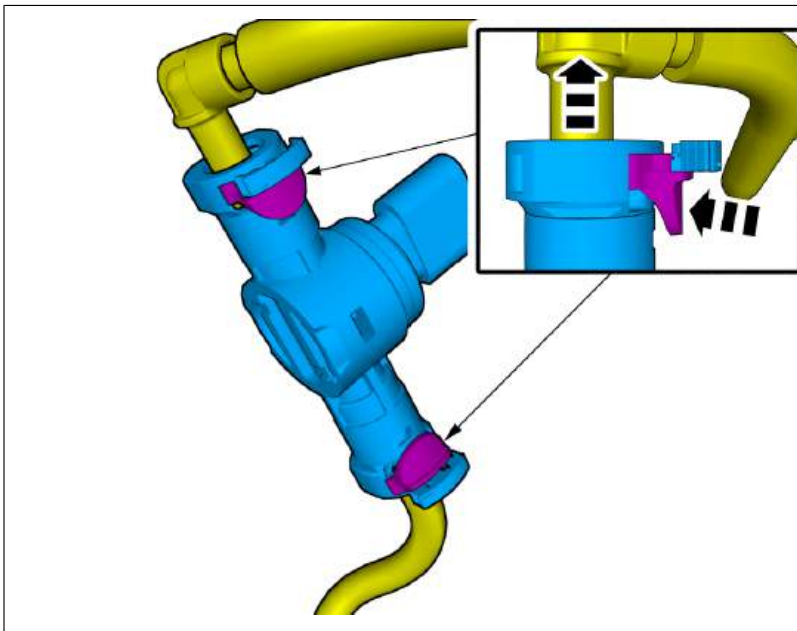

**Warning!** Be prepared to collect escaping fluid.

Depress the locking devices.  
Undo the hoses from the connections.  
Fold marked part aside.  
Remove the marked part.

## Extra information

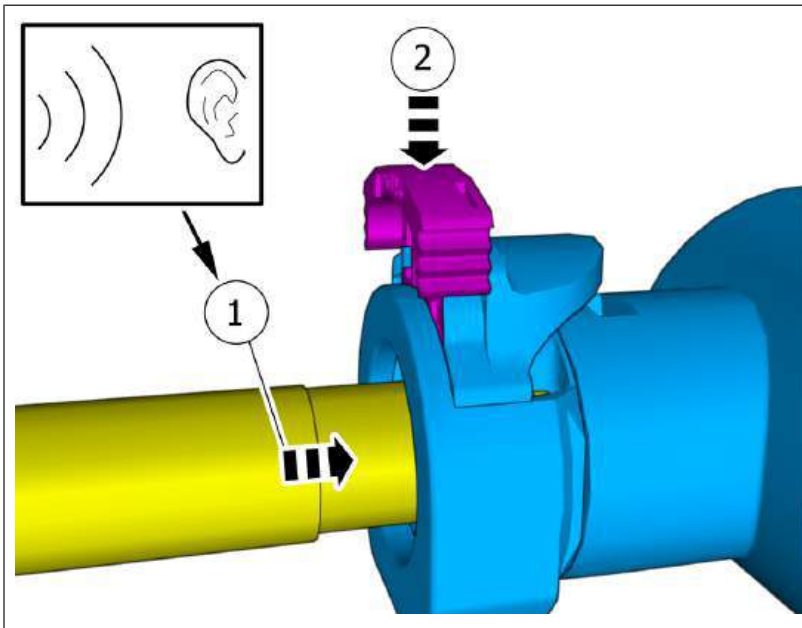

On both sides.

- 1 . Press until a click is heard.
- 2 . Depress the locking devices.

Continue the removal following the steps below.

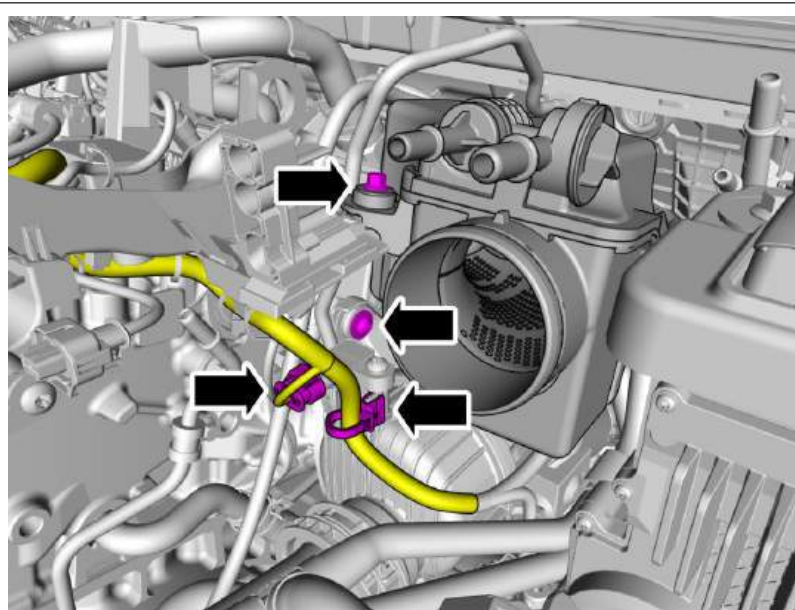

Remove the screws.  
Disconnect the connector.  
Loosen the clip.  
Fold the cable harness aside.

**Torque:**

M6 , 10 Nm

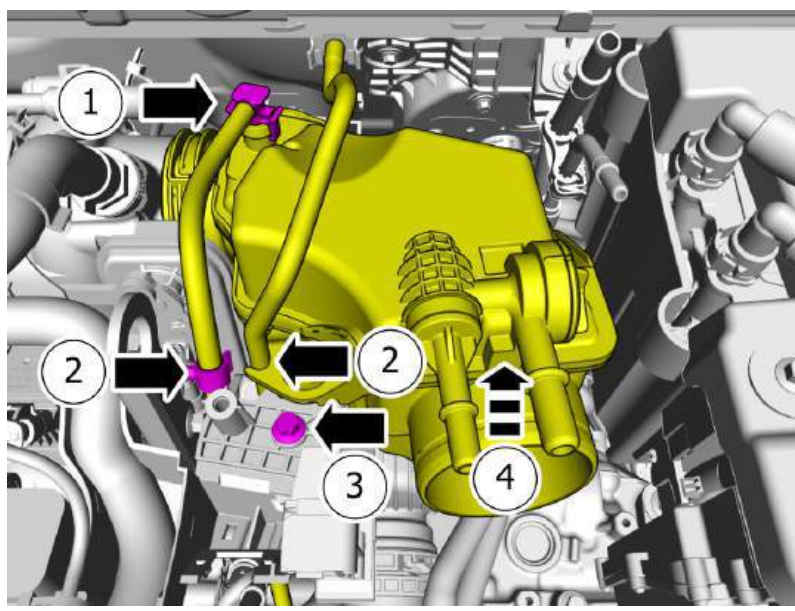

- 1 . Undo the hose from the connection.
- 2 . Loosen the marked details from the clip/ clips.
- 3 . Remove the screw.
- 4 . Turn in direction of arrow until stop.
- 5 . **Torque:**  
M6 , 10 Nm

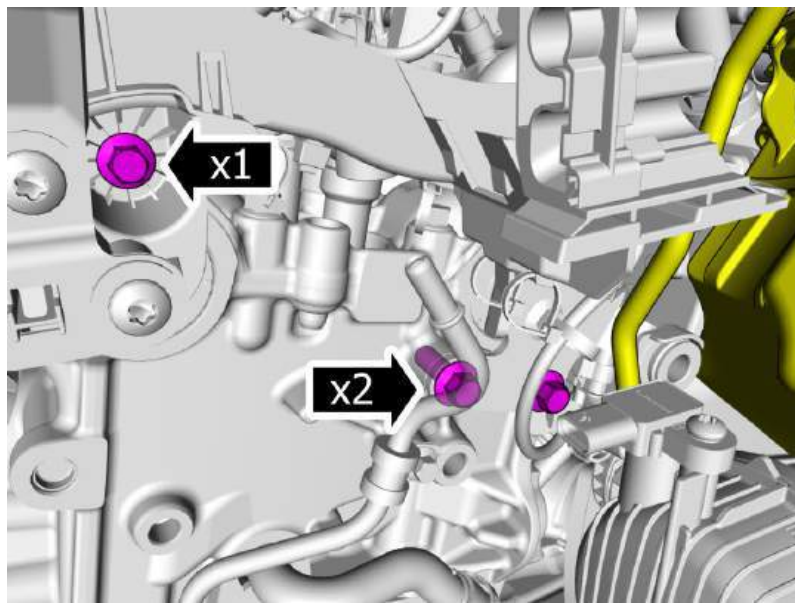

Remove the screws.

- 1 . **Torque:**  
M6 , 10 Nm
- 2 . **Torque:**  
M8 , 24 Nm

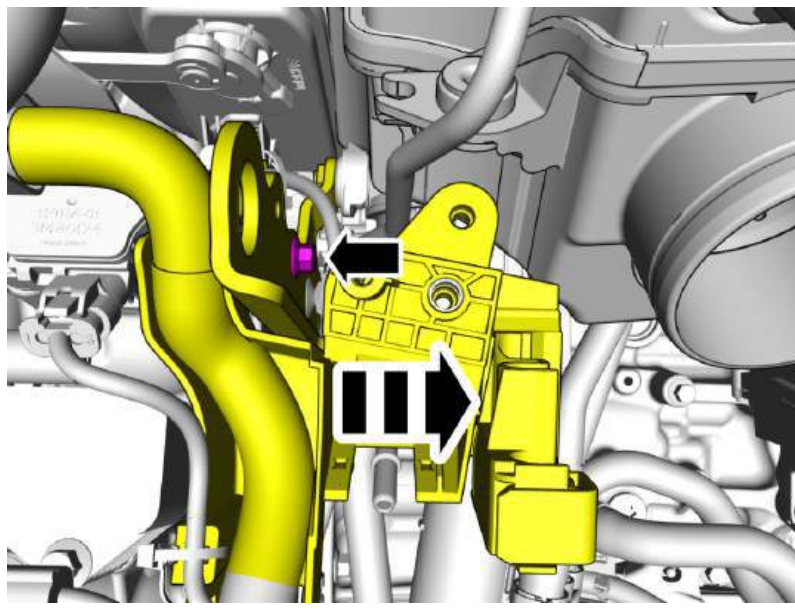

Fold marked parts aside.  
Remove the screw.

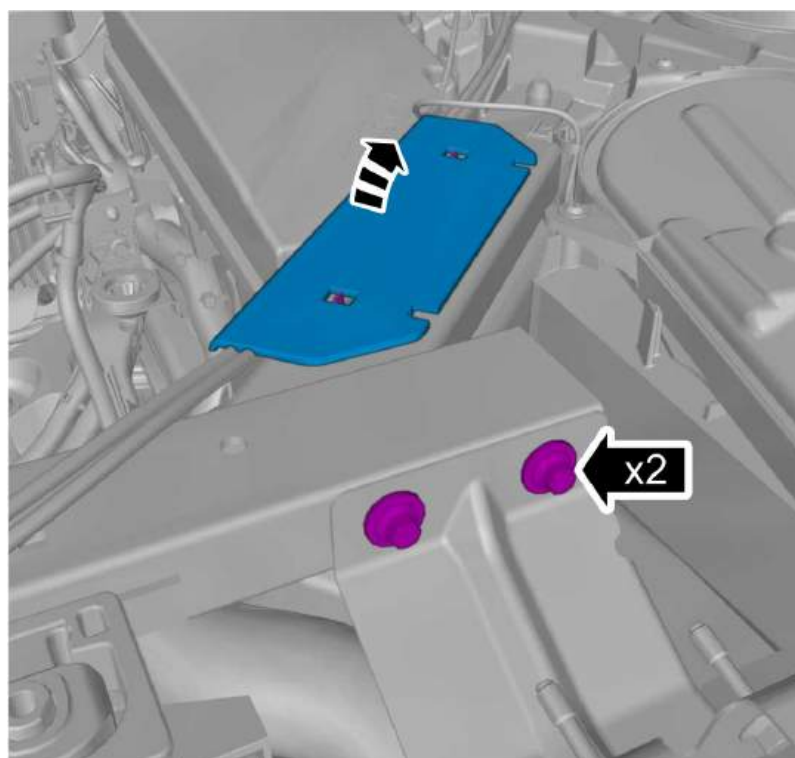

Remove the marked part.  
Remove the screws.  
On both sides.

**Torque:**

M6 , 10 Nm

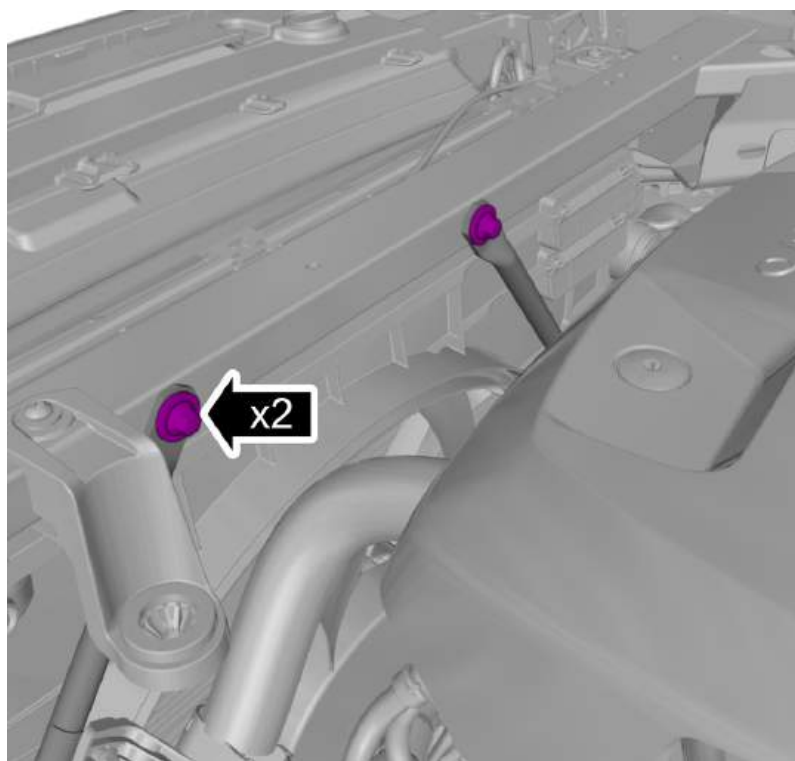

Remove the screws.

**Torque:**

M8 , 24 Nm

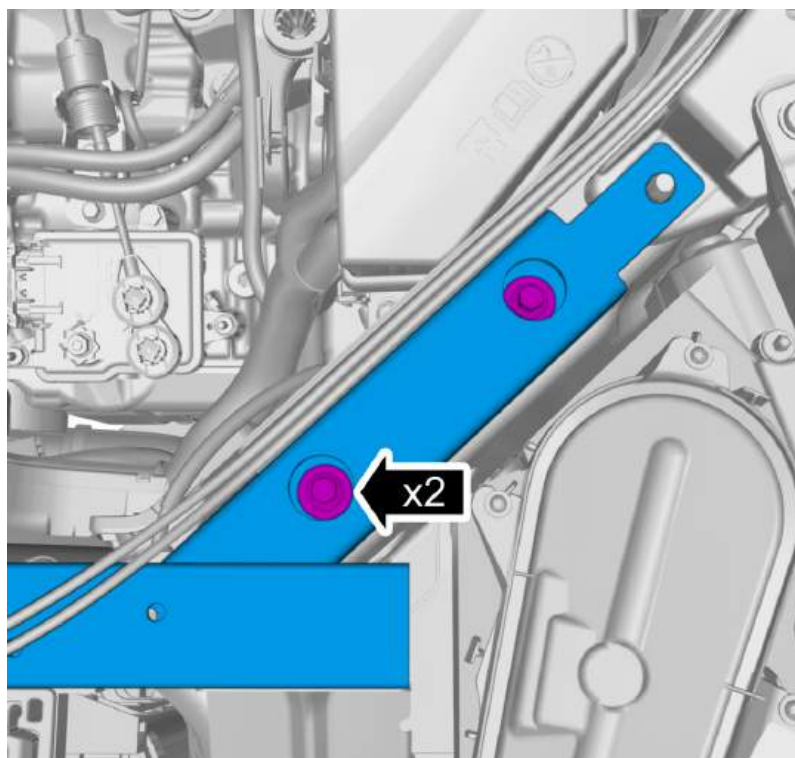

Remove the screws.

On both sides.

**Torque:**

Front end to upper side member , 30 Nm

Remove the marked part.

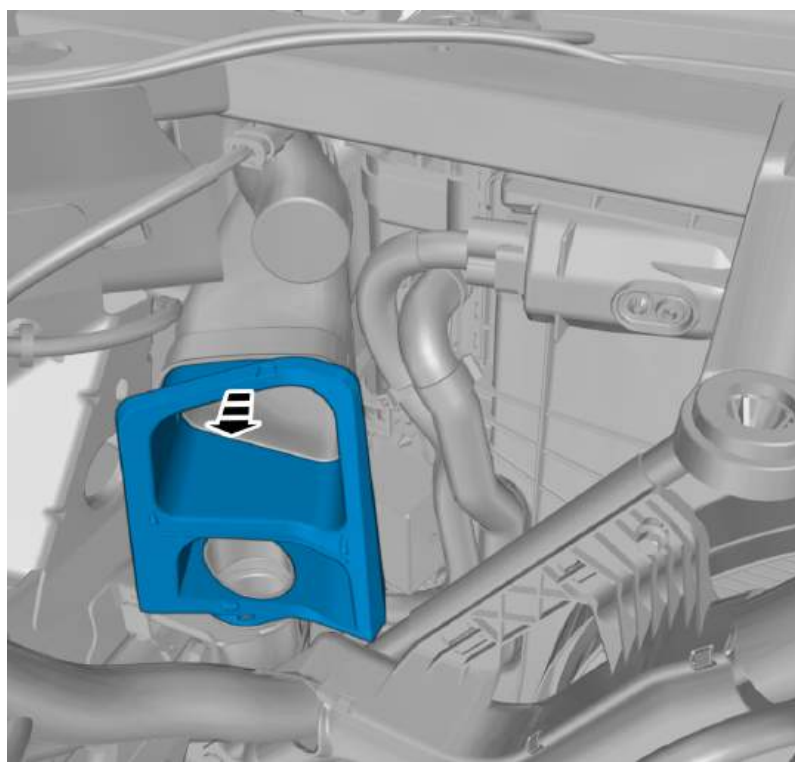

Remove the marked part.

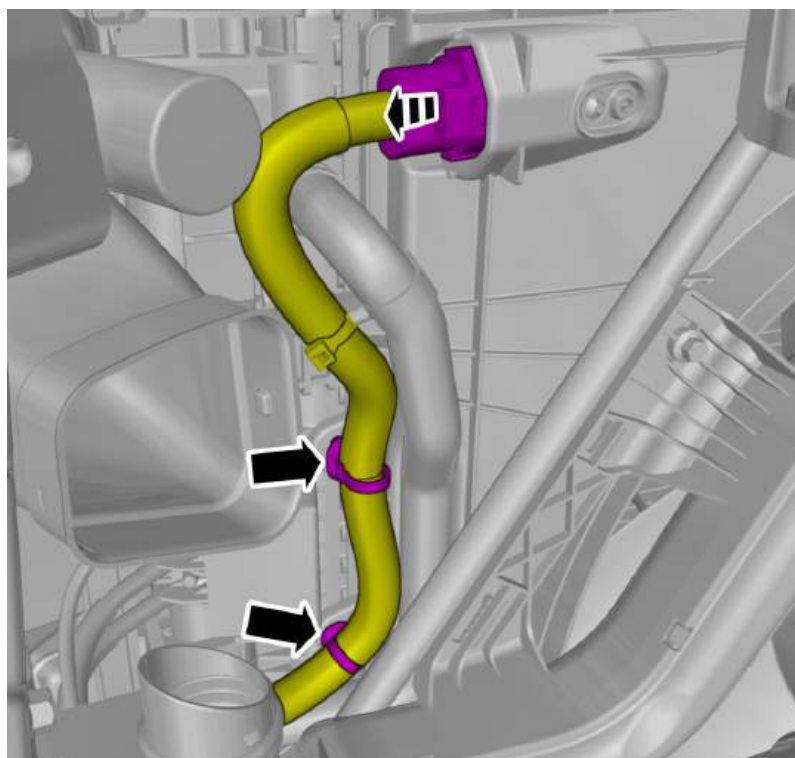

Disconnect the connector.  
Remove the cable harness clips.

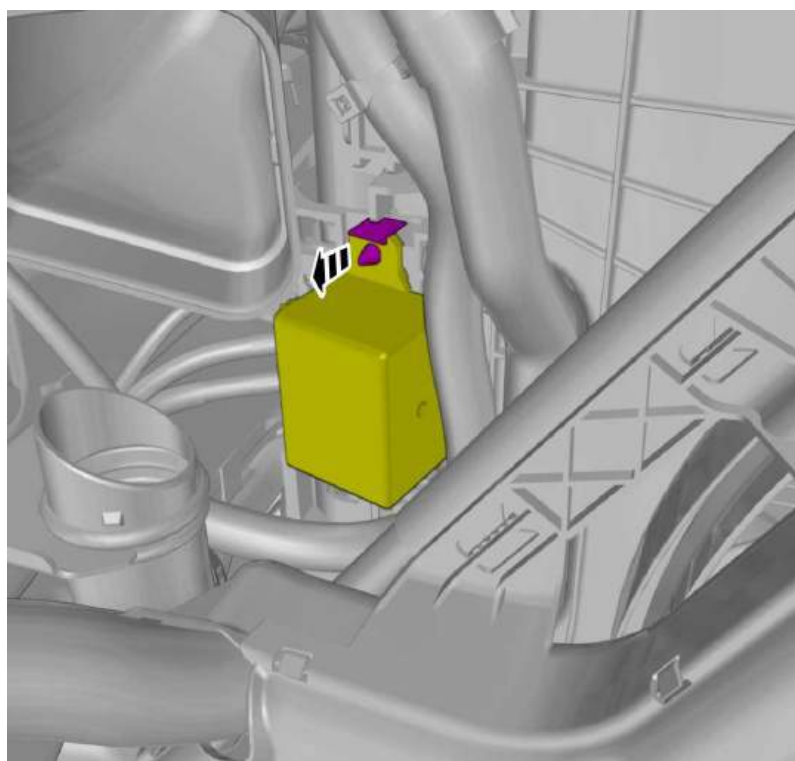

Fold marked part aside.

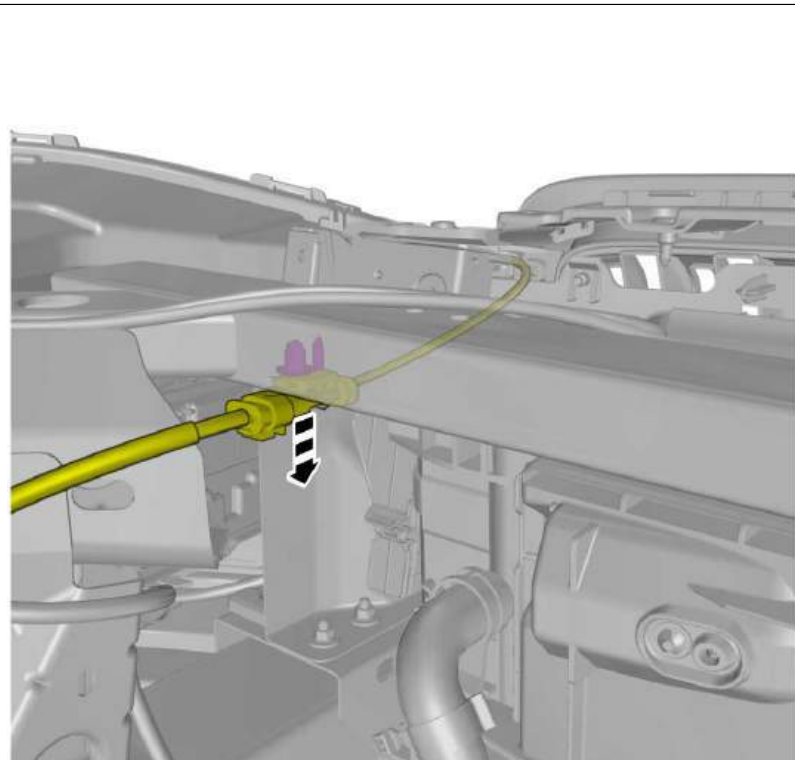

Remove the cable harness clips.

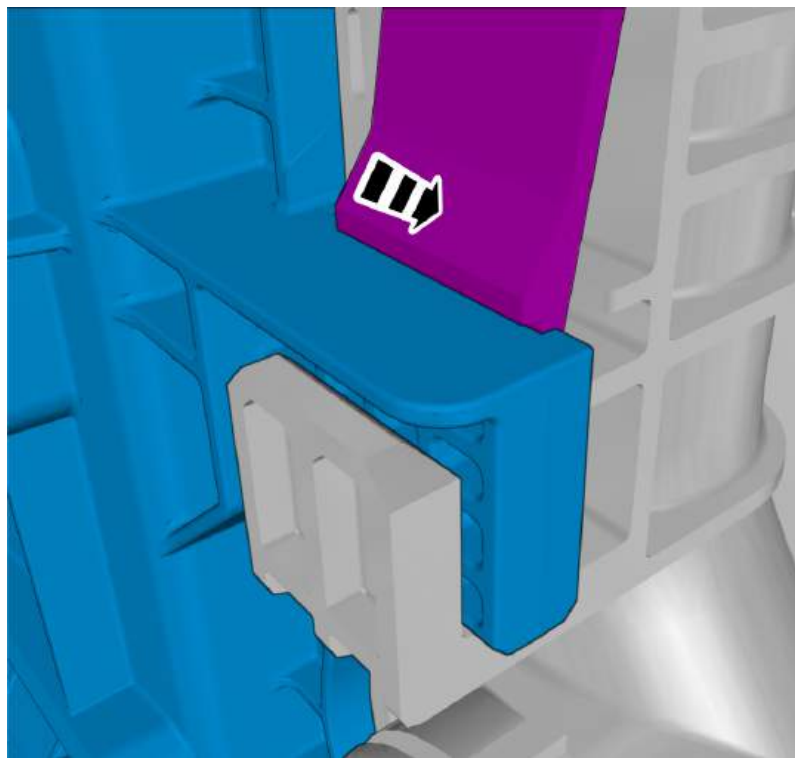

Press the marked component.

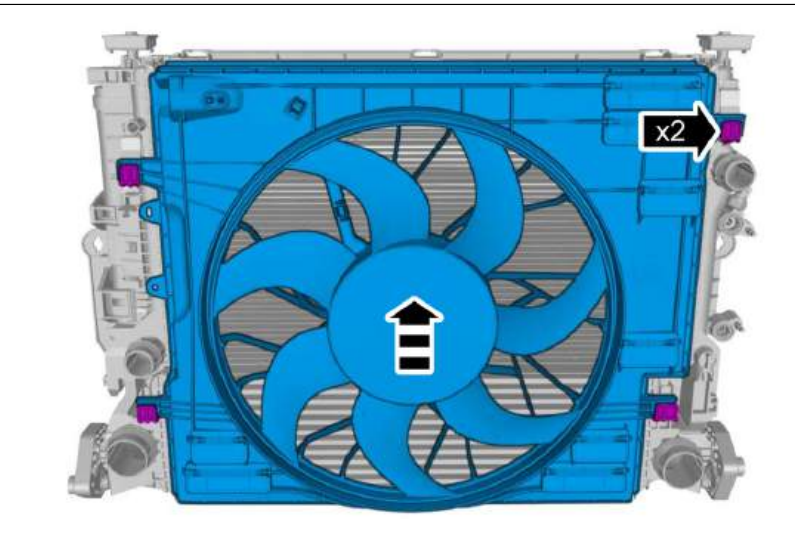

**Hint: It may be necessary to twist or turn the component.**

Remove the marked part.

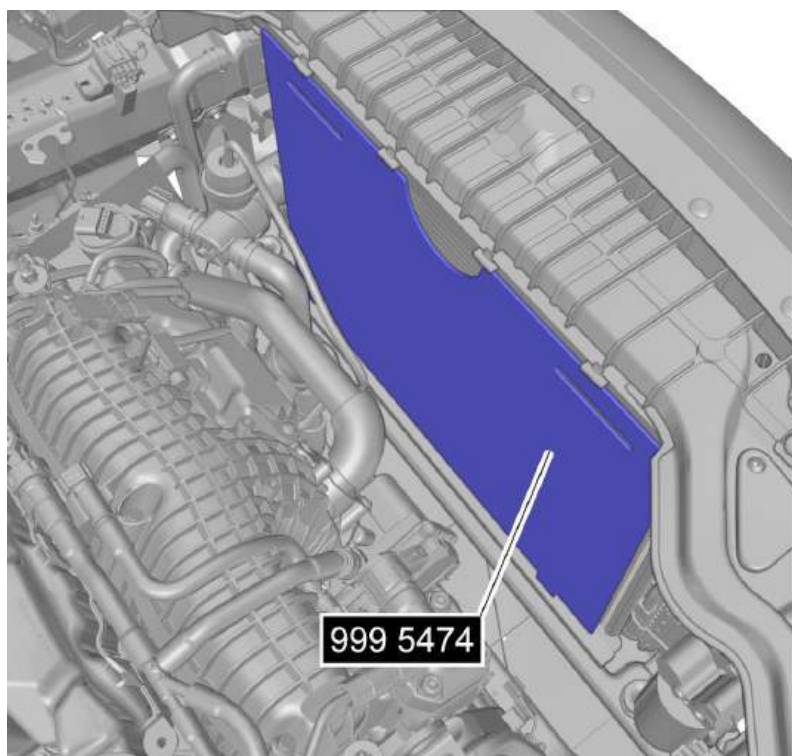

Place the component where indicated in the graphic.

Special Tool: T9995474, RADIATOR PROTECTION

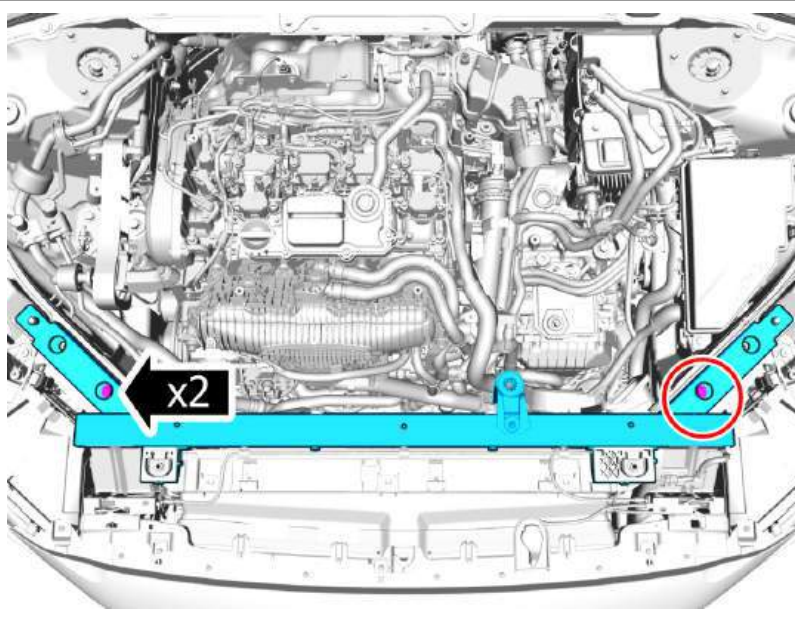

Install the marked component.  
Install the screws.

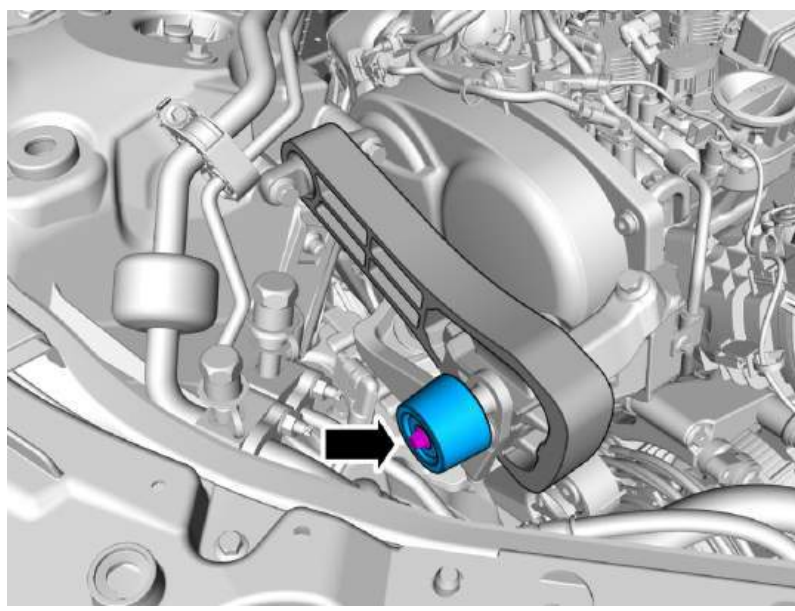

Loosen the screw.  
Remove the marked part.

**Torque:**

M6 , 10 Nm

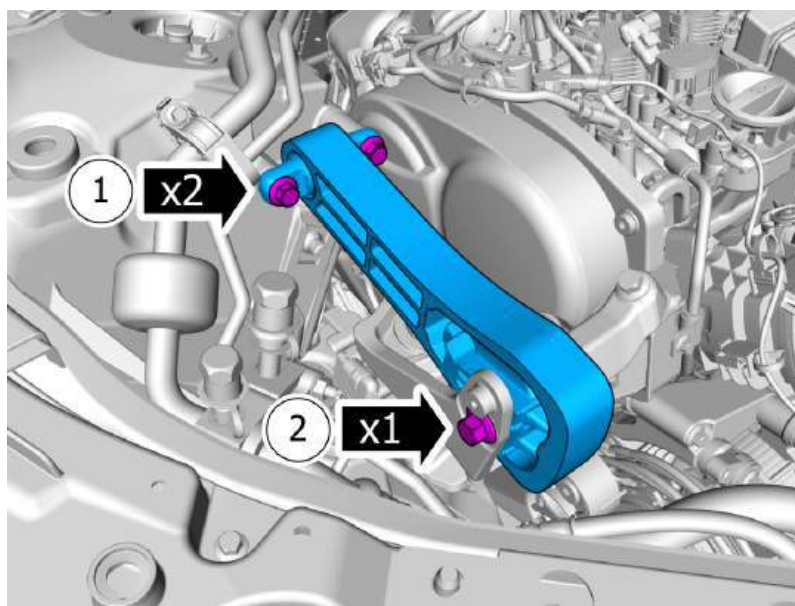

**Note! Make sure to follow the correct sequence during installation.**

Remove the screws.

1 · **Torque:**

Upper torque rod to spring strut turret ,  
60 Nm

2 · **Torque:**

Upper torque rod to engine mount  
bracket , 110 Nm

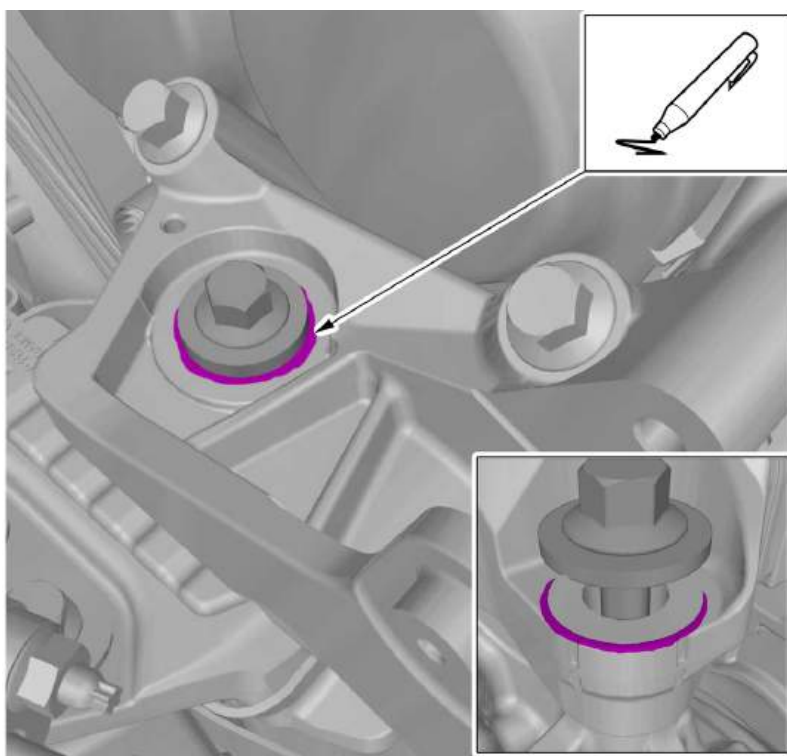

**Caution! Note the position of the component before removal.**

**Use:** Marker pen

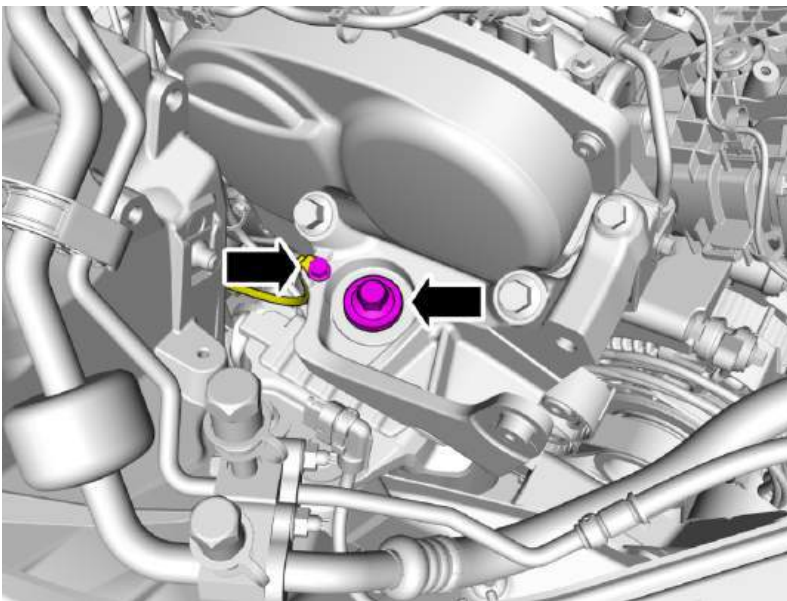

Remove the screws.

- 1 · **Torque:**  
M6 , 10 Nm
- 2 · **Torque:**  
Engine mount bracket, to Engine pad ,  
110 Nm

Remove right side the front wheel , refer to:  
Removal, replacement and installation  
7 - Springs and wheels  
77 - Wheels, tyres  
770 - complete wheels

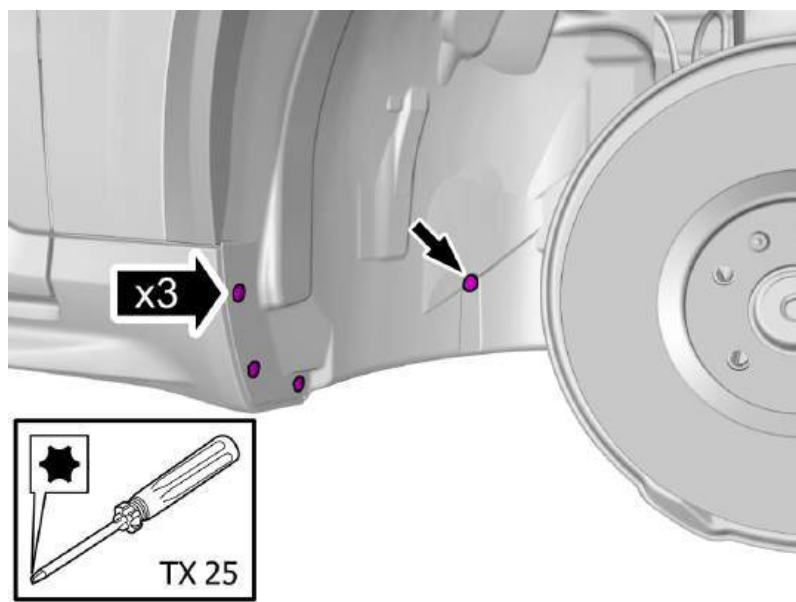

Remove the clip.  
Remove the screws.

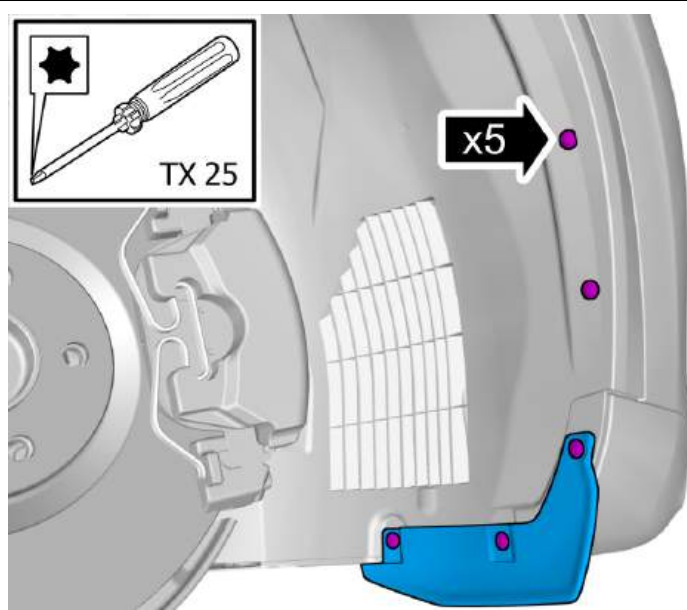

Remove the screws.  
Remove the marked part.

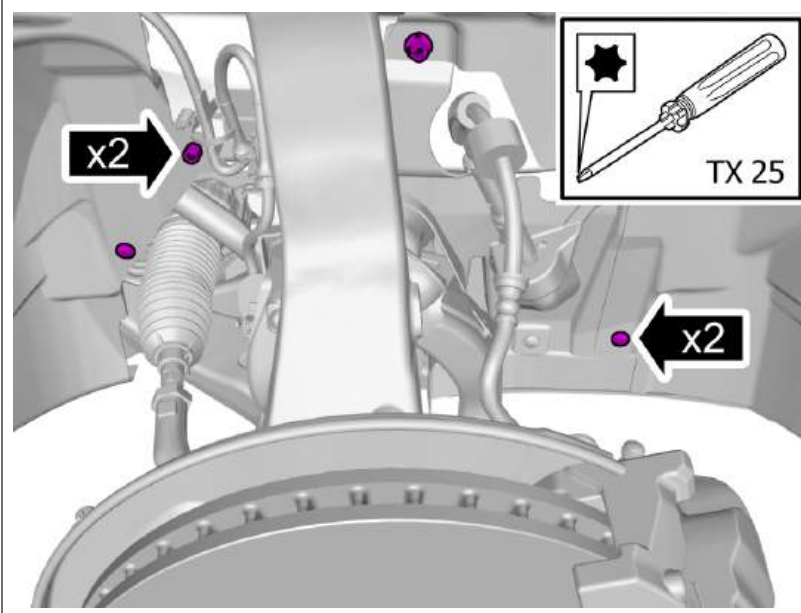

Remove the screws.  
Remove the nuts.

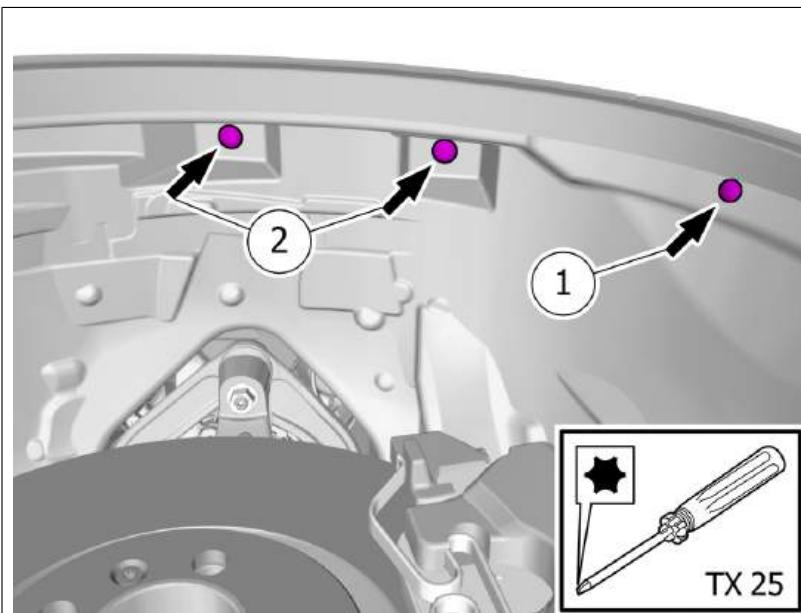

Remove the screw.  
Remove the clips.

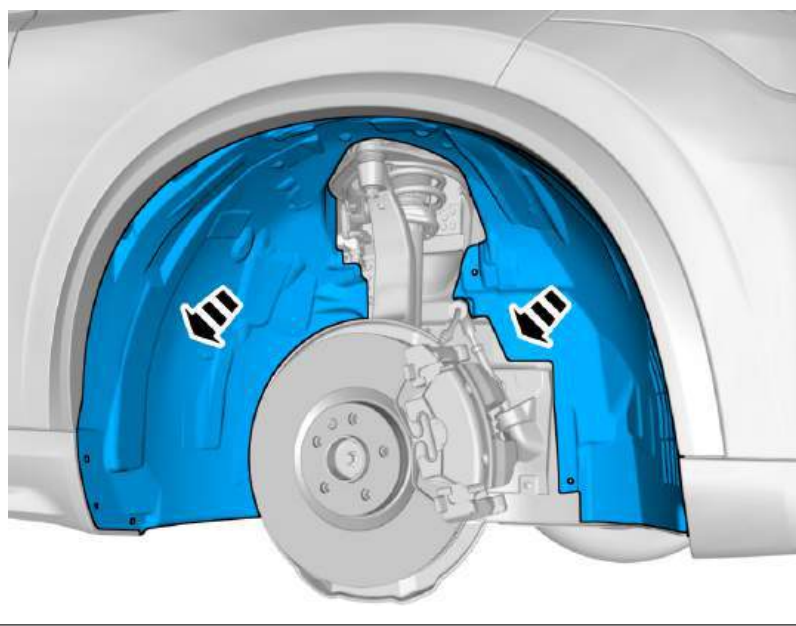

Remove the marked part.

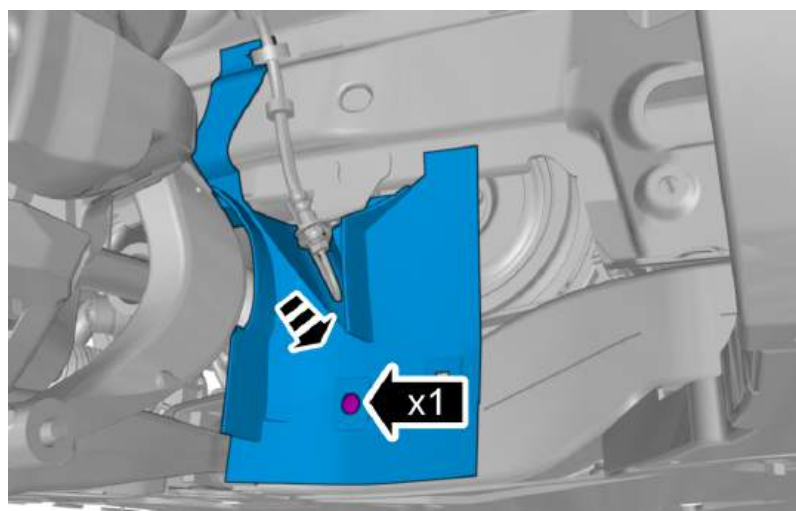

Remove the screw.  
Remove the marked part.

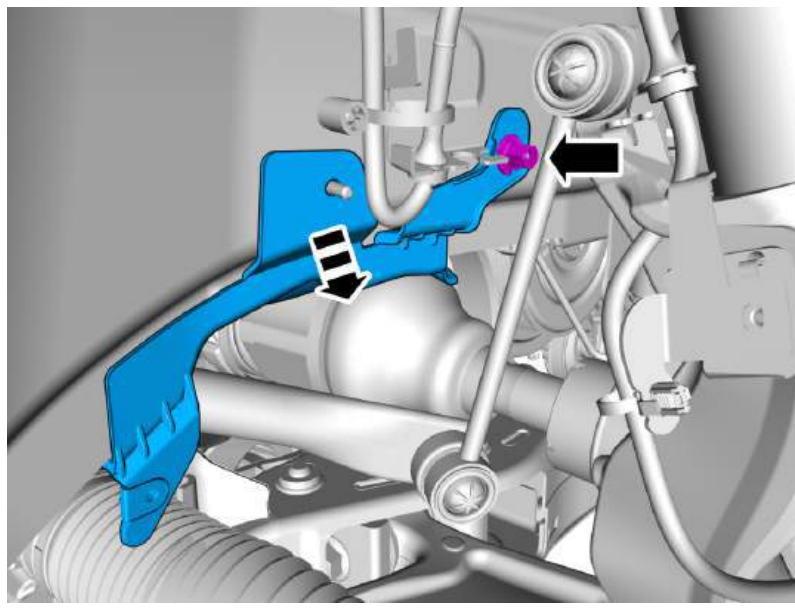

Remove the nut.  
Remove the marked part.

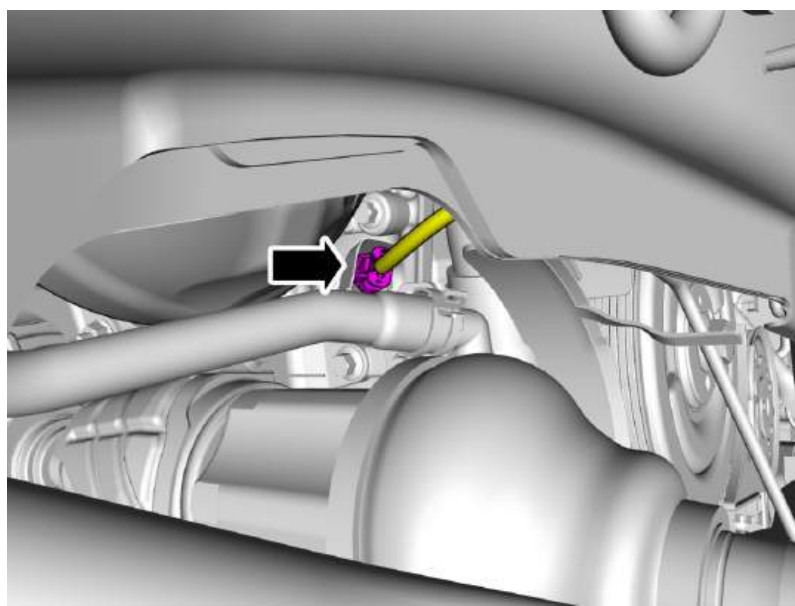

Disconnect the connector.  
Remove the cable harness clips.

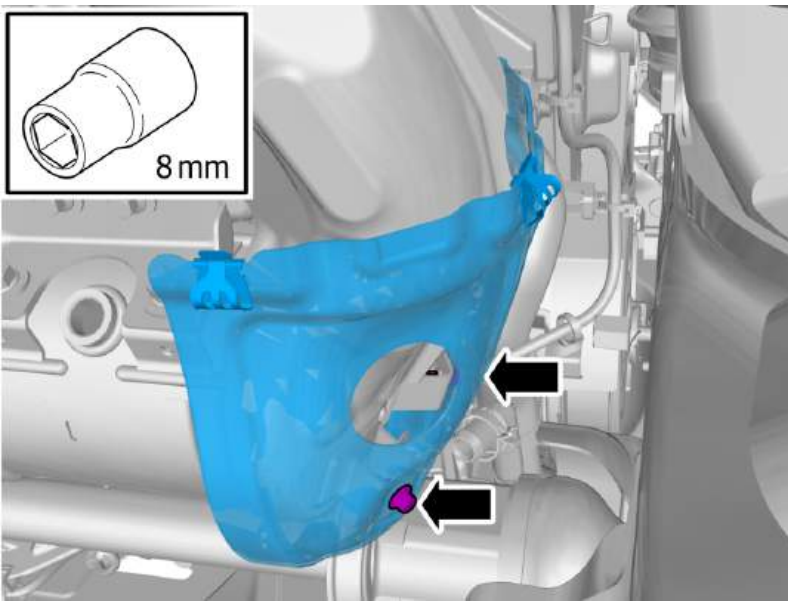
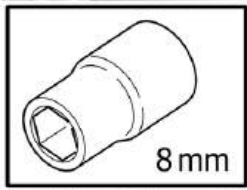

**Note! Do not loosen the bolts more than 2 turns.**

Loosen the screws.

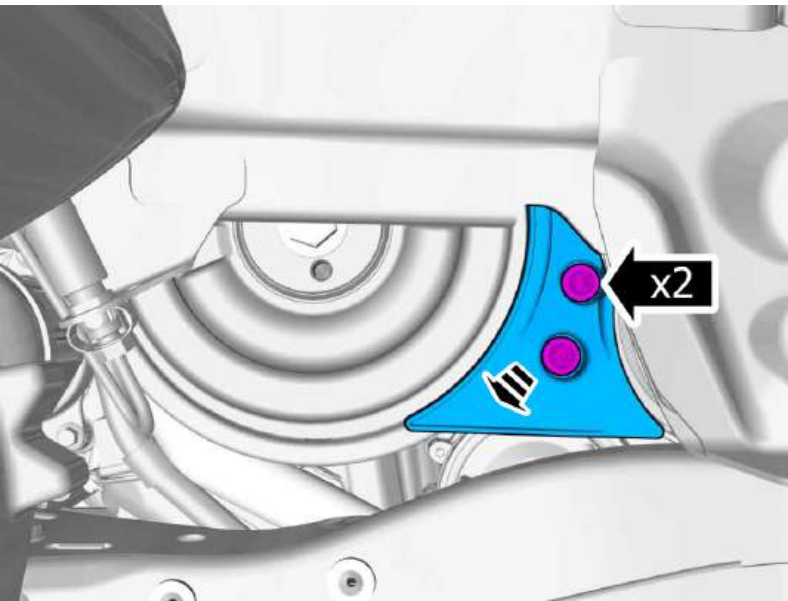

Remove the screws.  
Remove the marked part.



Remove the screws.  
Remove the marked part.

**Torque:**  
M6 , 10 Nm

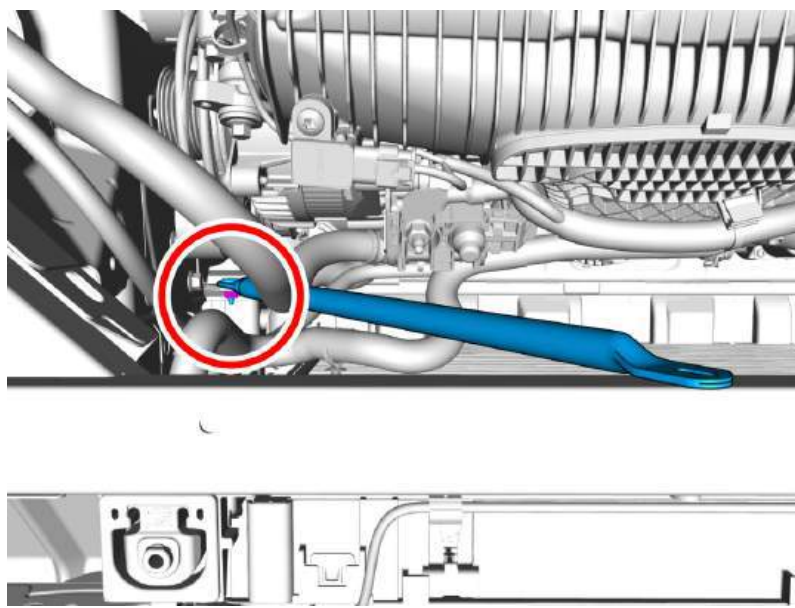

**Note! Orientation view**

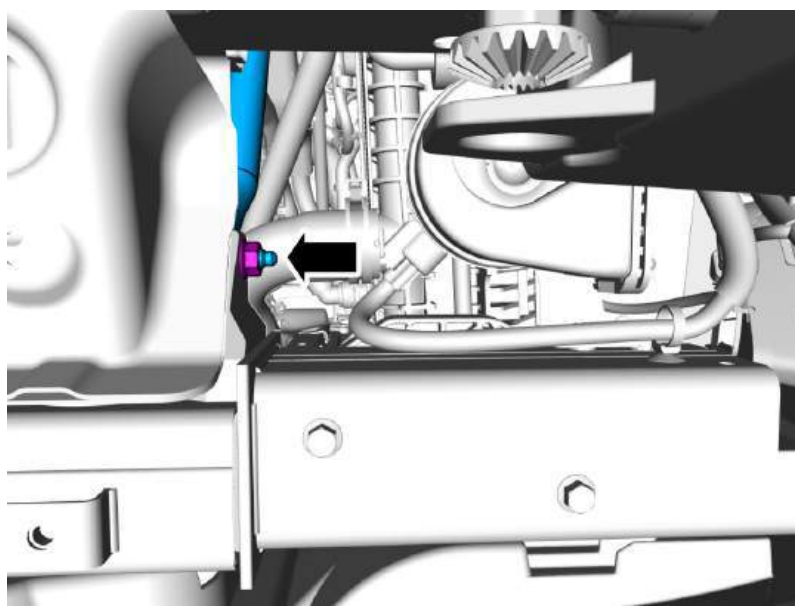

Remove the nut.  
Remove the marked part.

**Torque:**

M8 , 24 Nm

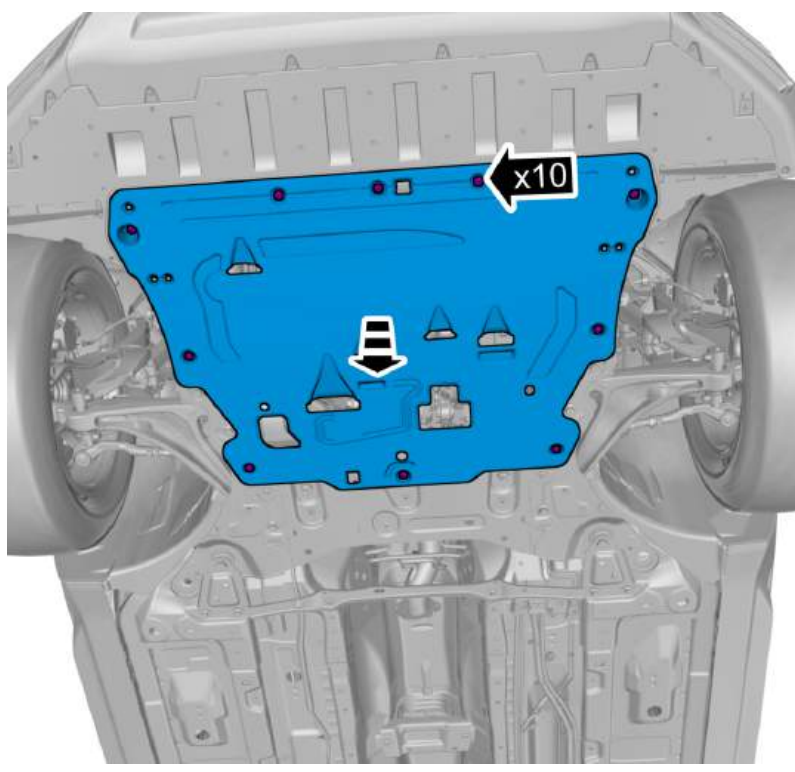

Remove the screws.  
Remove the clips.  
Remove the marked part.

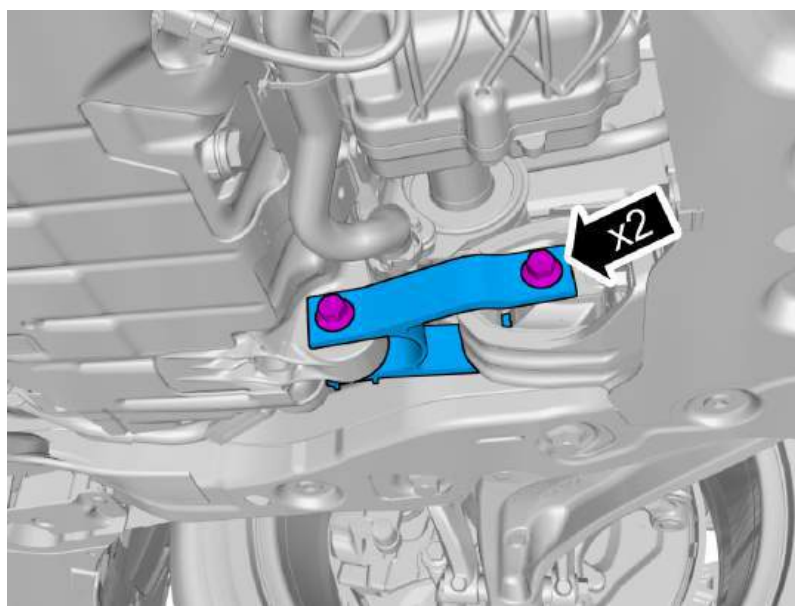

Remove the screws.  
Remove the marked part.

**Torque:**

Lower torque rod rear right, to Engine mount bracket , 110 Nm

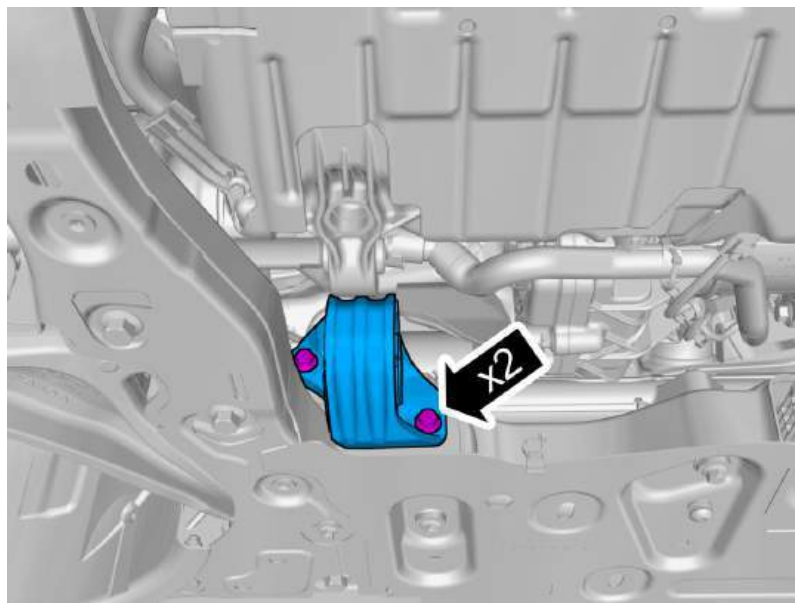

Remove the screws.  
Remove the marked part.

**Torque:**

Lower torque rod rear right, to subframe , 60 Nm

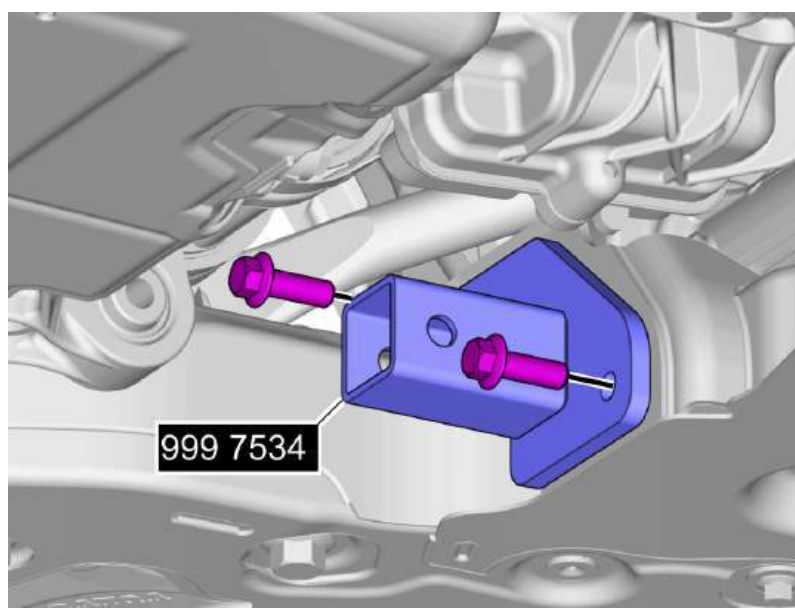

Install the Special tool.  
Install the screws.

**Use:** Screw M10 x 20 mm

Special Tool: T9997534, Mounting

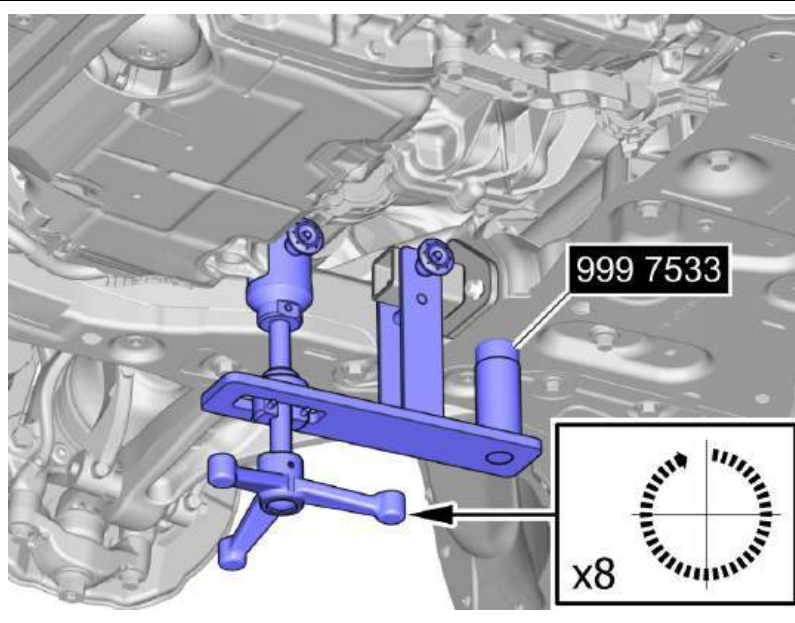

Install the Special tool.  
Adjust to the specified value.

Special Tool: T9997533, Support

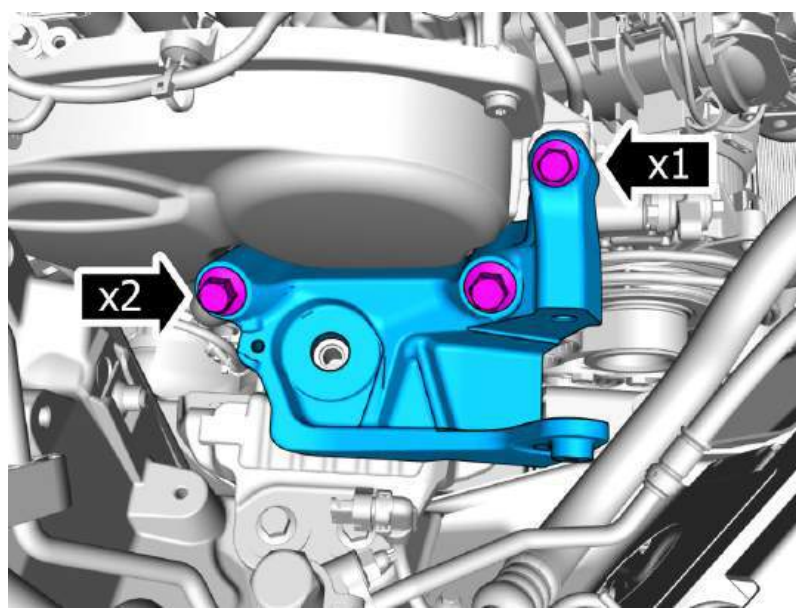

Remove the screws.  
Remove the marked part.

1. **Torque:**
  - Stage 1 : Engine mount bracket, to Cylinder head, M12 , 90 Nm
  - Stage 2 : Engine mount bracket, to Cylinder head, M12 , 130°
2. **Torque:**
  - Engine mount bracket, to Cylinder head, M10 , 60 Nm

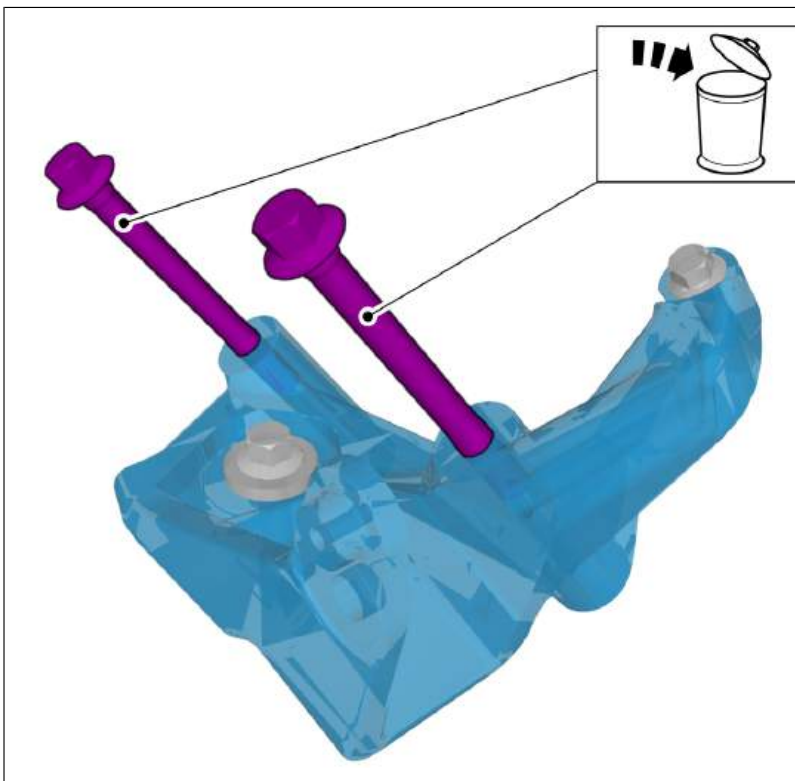

**Caution! Make sure that new bolts are installed.**

Vehicles early version

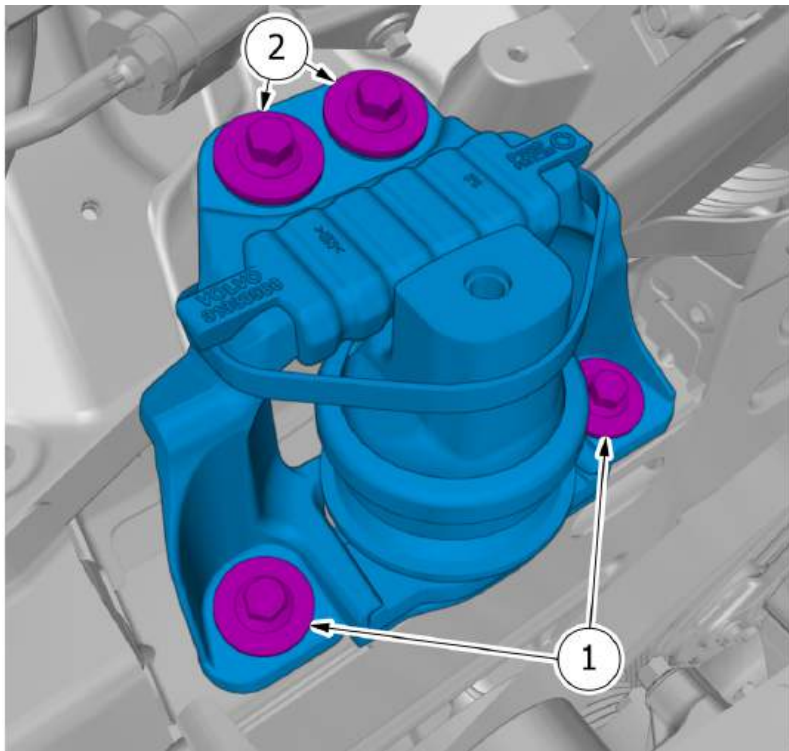

**Note! Make sure to follow the correct sequence during installation.**

Remove the screws.  
Remove the marked part.

**Torque:**

Right-hand engine pad to body frame ,  
60 Nm

Vehicles late version

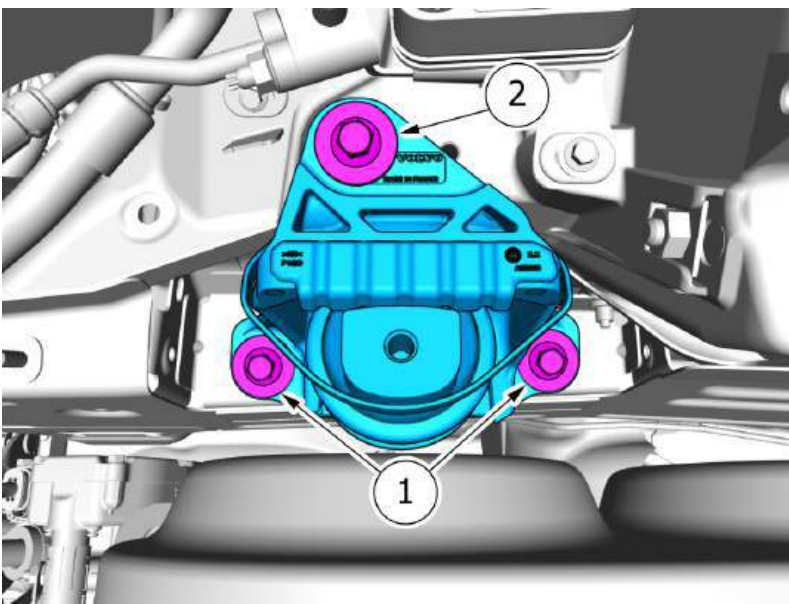

**Note! Make sure to follow the correct sequence during installation.**

Remove the screws.  
Remove the marked part.

**Torque:**

Right-hand engine pad to body frame ,  
60 Nm

All vehicles

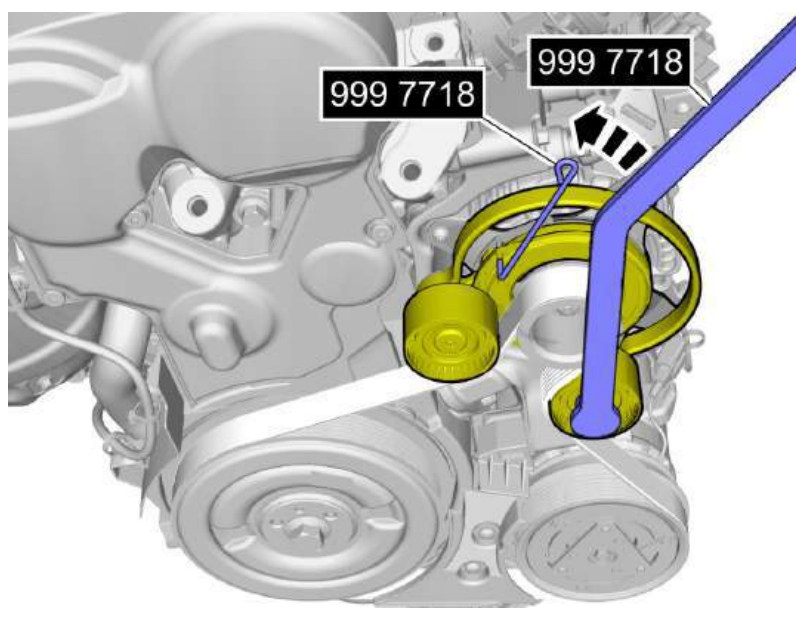

Special Tool: T9997718, Counterhold

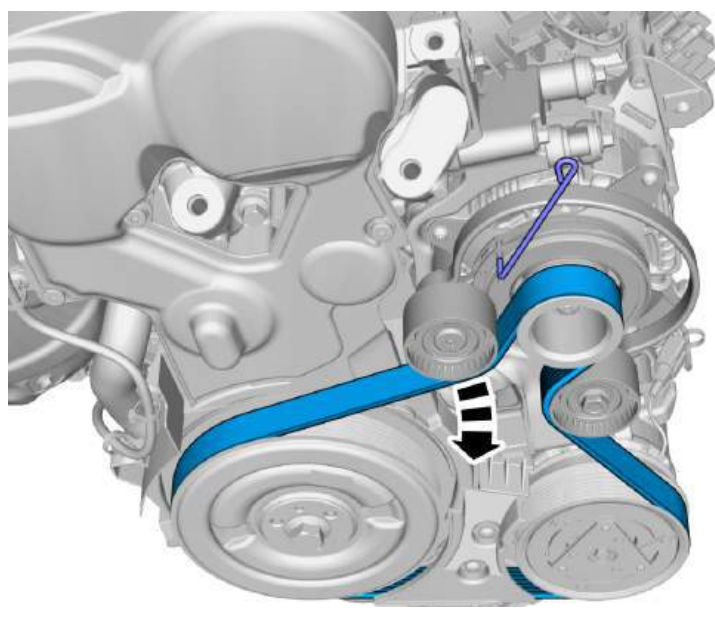

Remove the marked part.

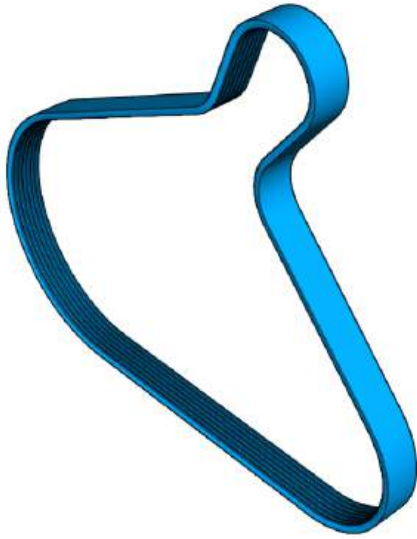

**Note!** The component can be reused unless it has been subjected to abnormal mechanical stress, damage or oil contamination.

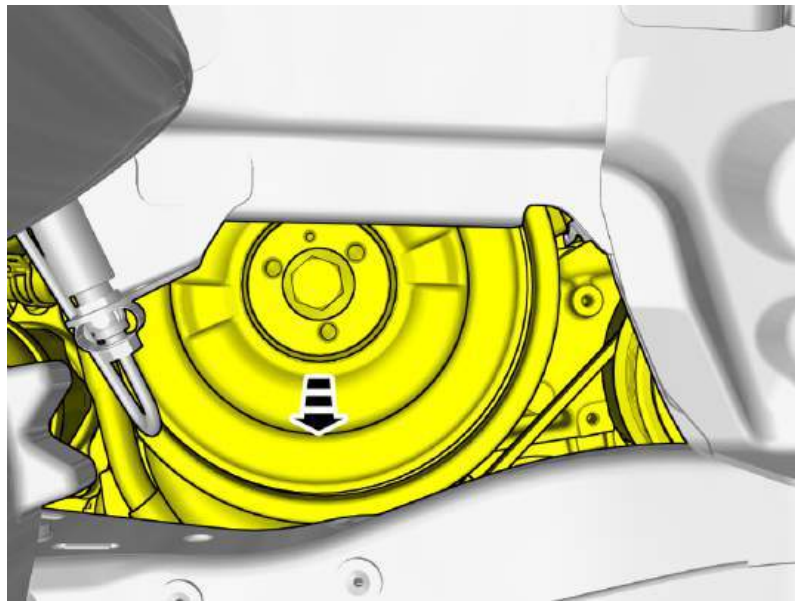

Lower the engine.

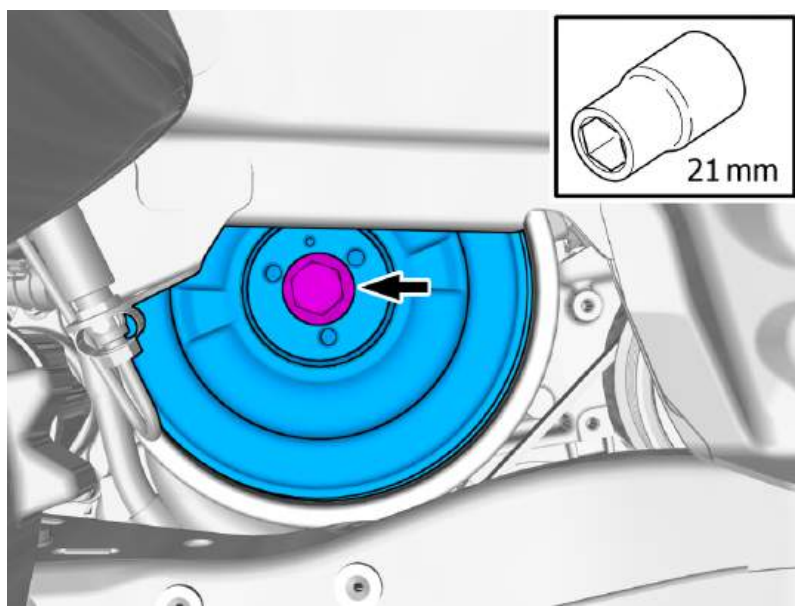

**Note!** Note the position of the component before removal.

**Extra information**

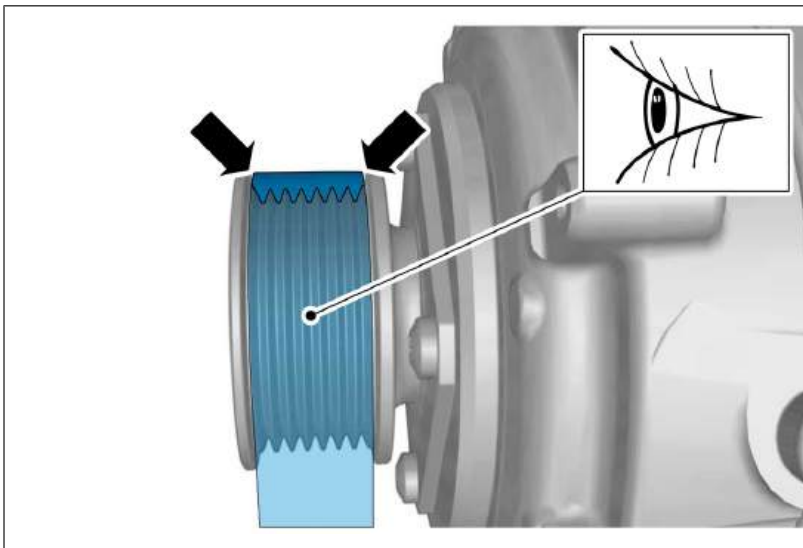

**Caution!** Make sure that the component is positioned correctly.

Continue the removal following the steps below.

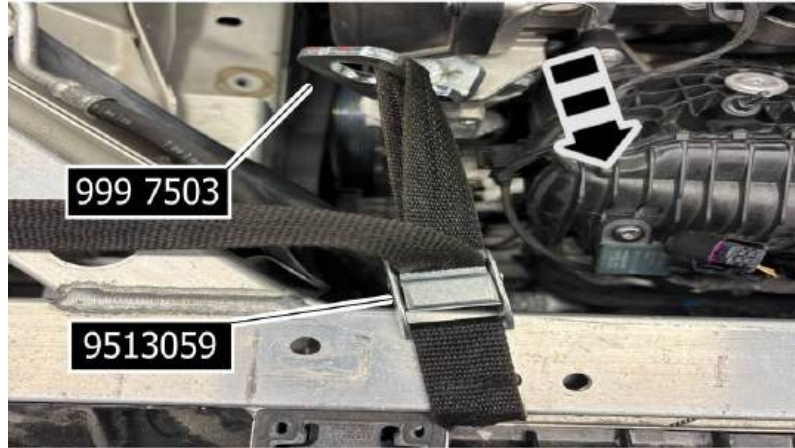

Install the Special tool.  
Pull the component in direction of the arrow.

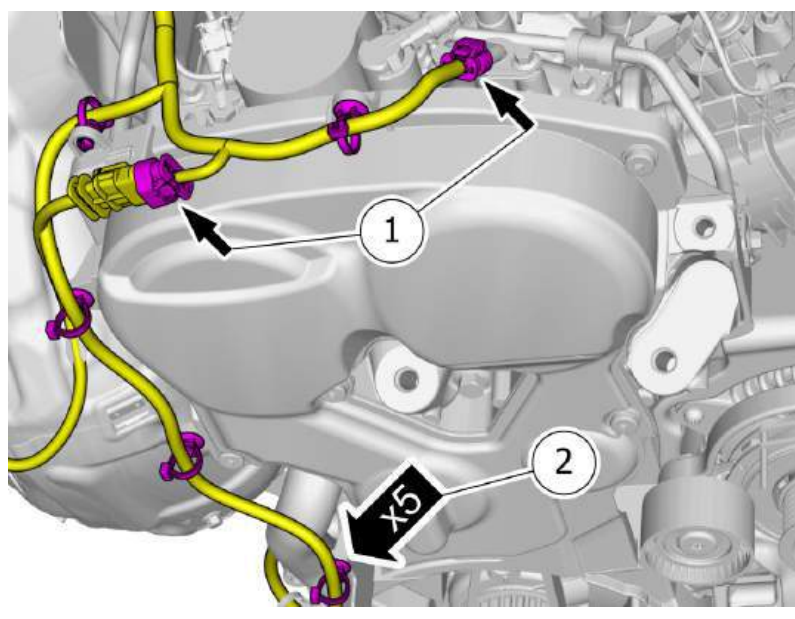

Disconnect the connectors.  
Remove the cable harness clips.

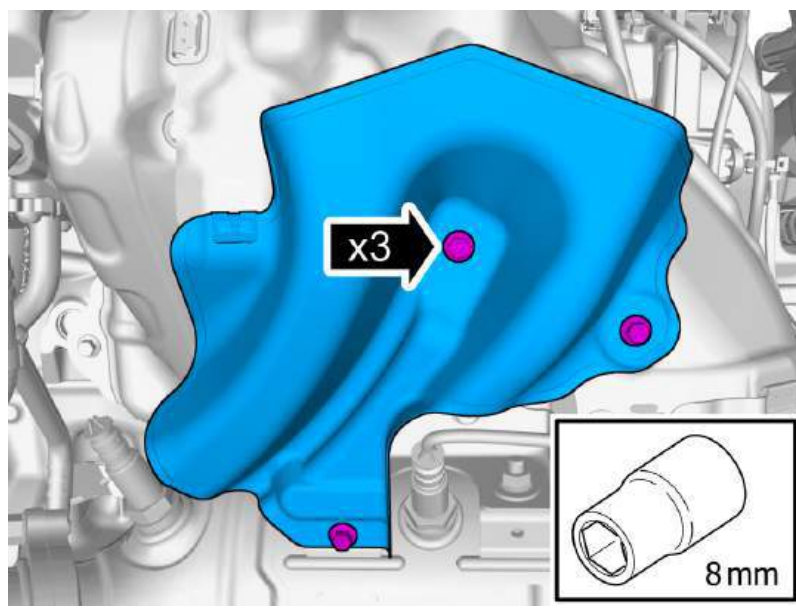

Remove the screws.  
Remove the marked part.

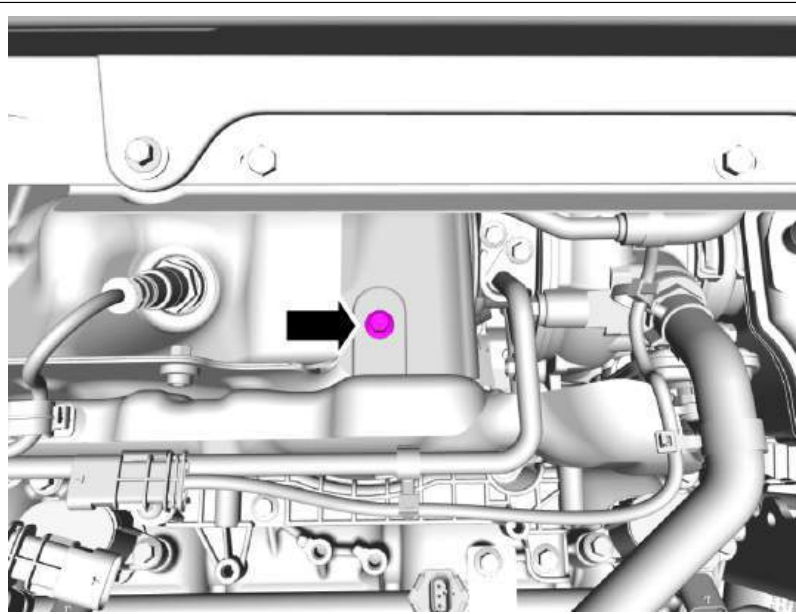

Remove the screw.

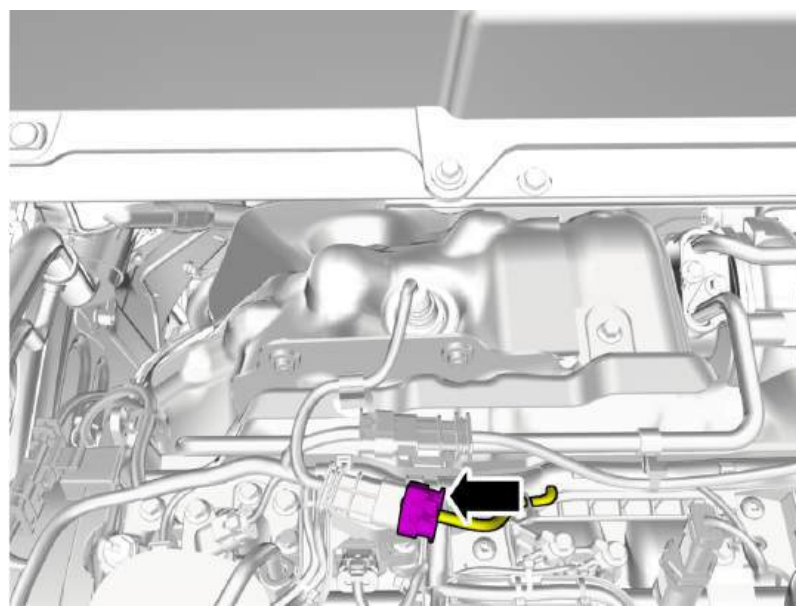

Disconnect the connector.

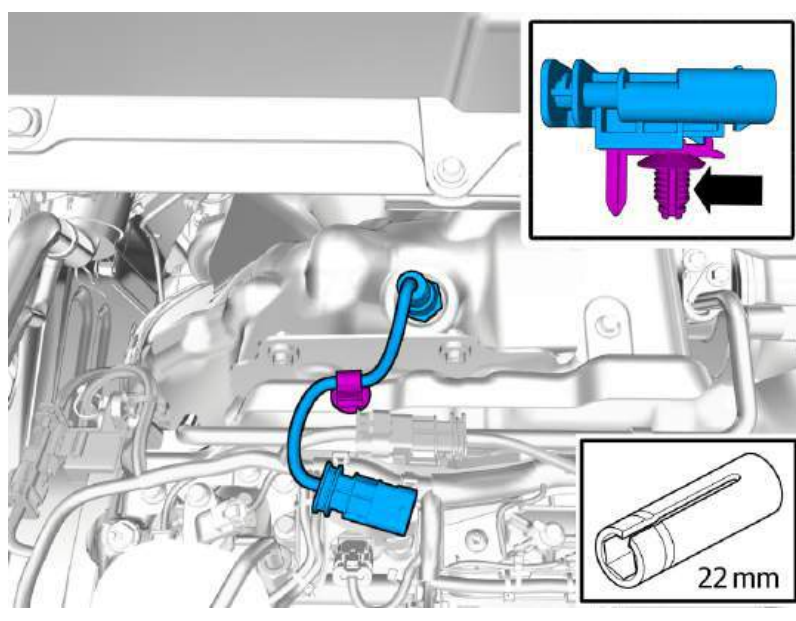

Loosen the clips.  
Remove the marked part.

**Torque:**

Lambda probe, tightening , 45 Nm

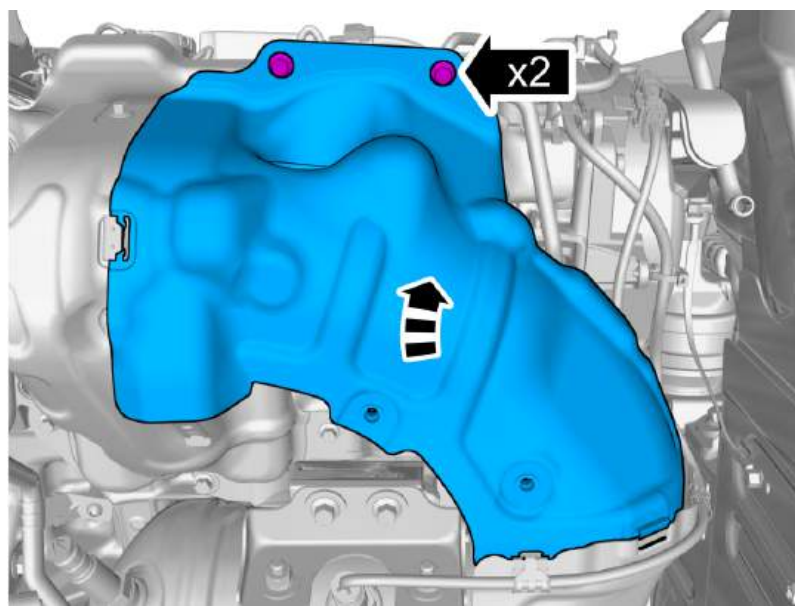

Remove the screws.  
Remove the marked part.

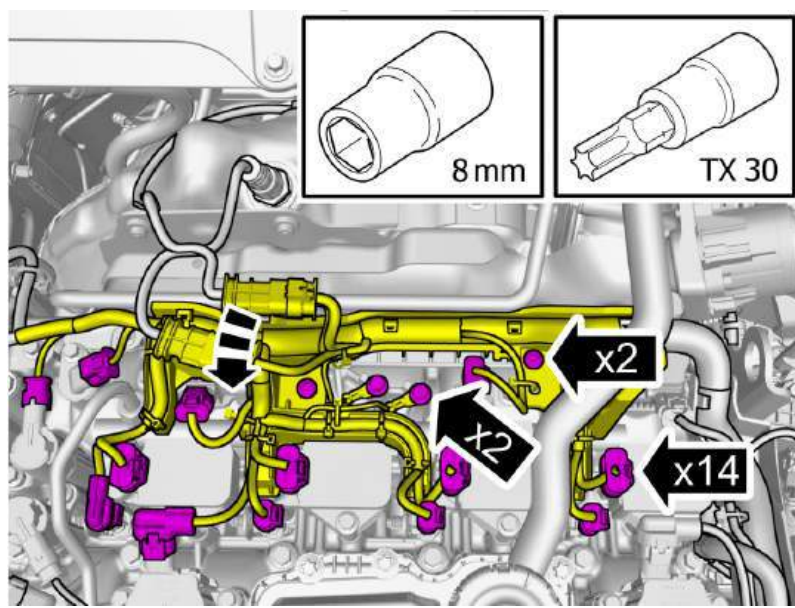

Remove the screws.  
Disconnect the connectors.  
Fold marked part aside.

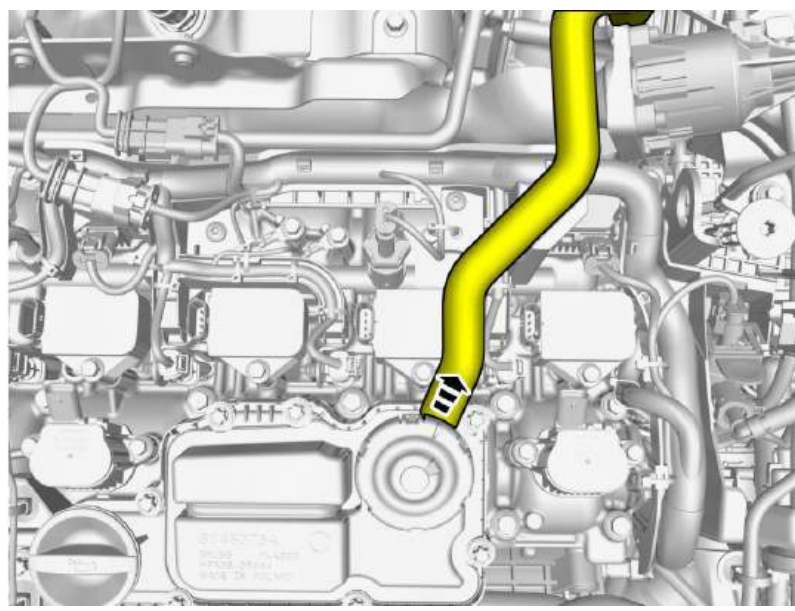

Undo the hose from the connection.  
Fold marked part aside.

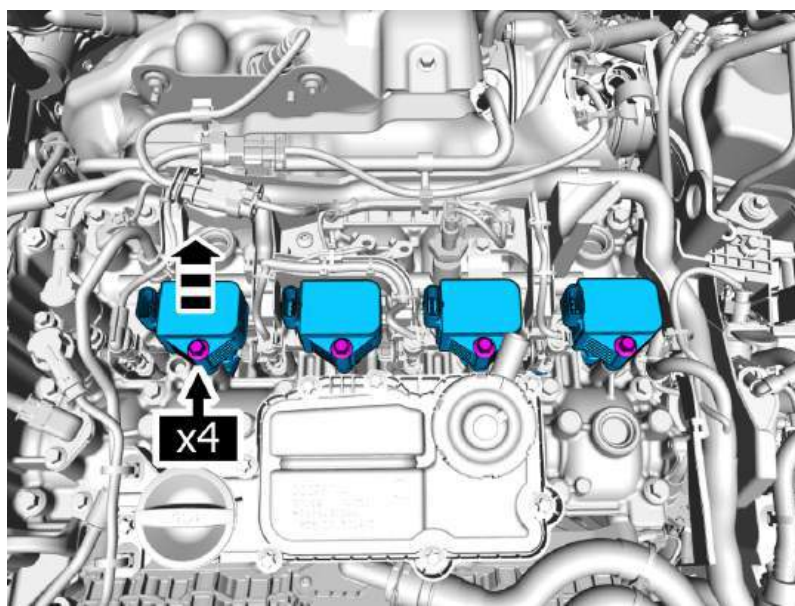

Remove the screws.  
Remove the marked parts.

**Torque:**

M6 , 10 Nm

## Extra information

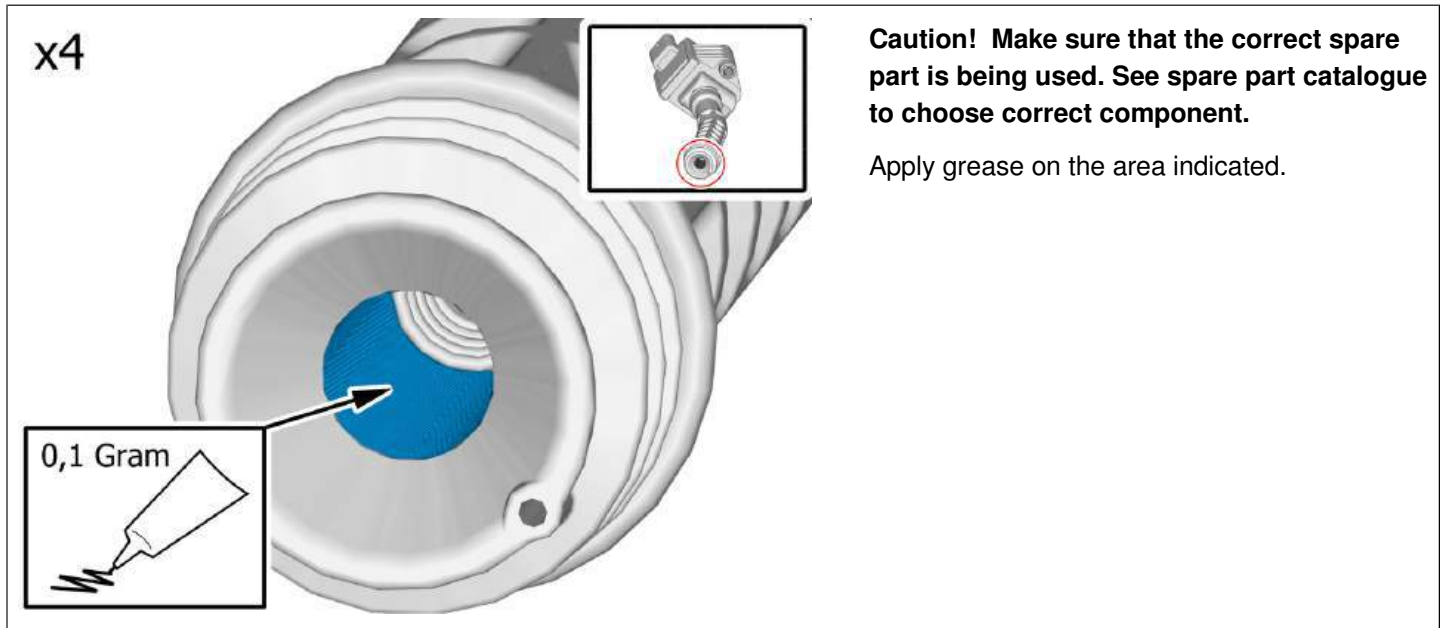

Continue the removal following the steps below.

Vehicles early version

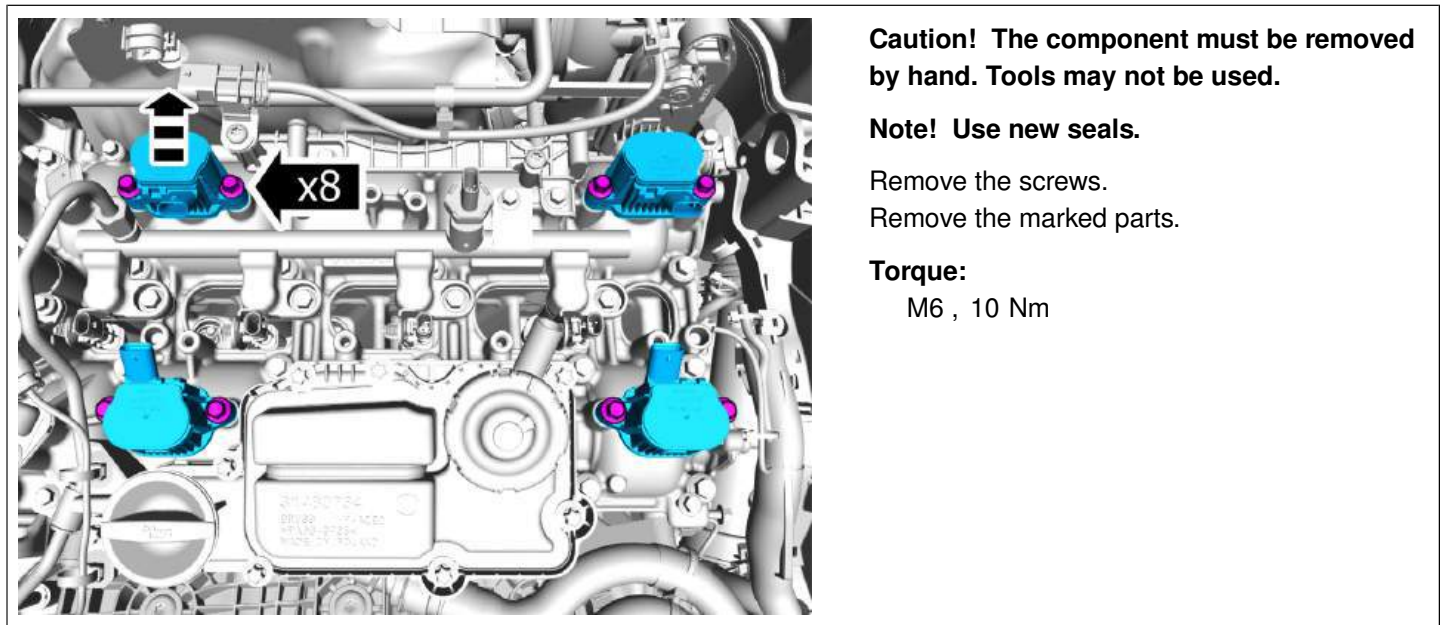

All vehicles

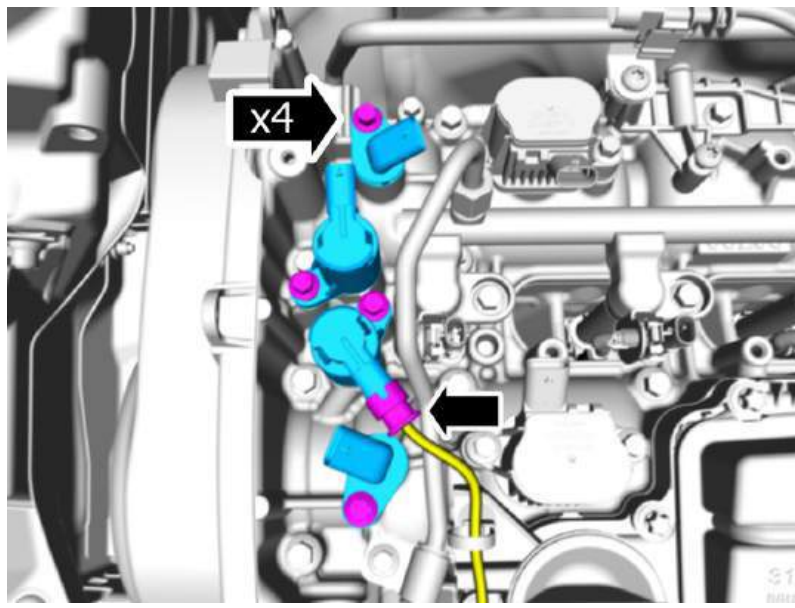

Disconnect the connector.  
Remove the screws.  
Remove the marked parts.

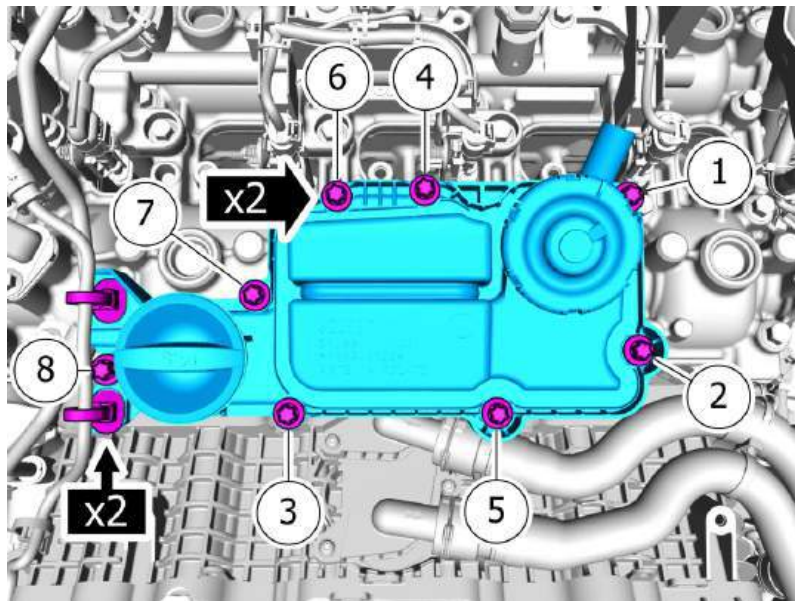

**Note! Make sure to follow the correct sequence during installation.**

**Note! Use a new seal.**

Remove the clips.  
Remove the screws.  
Remove the marked part.

**Torque:**

M6 , 10 Nm

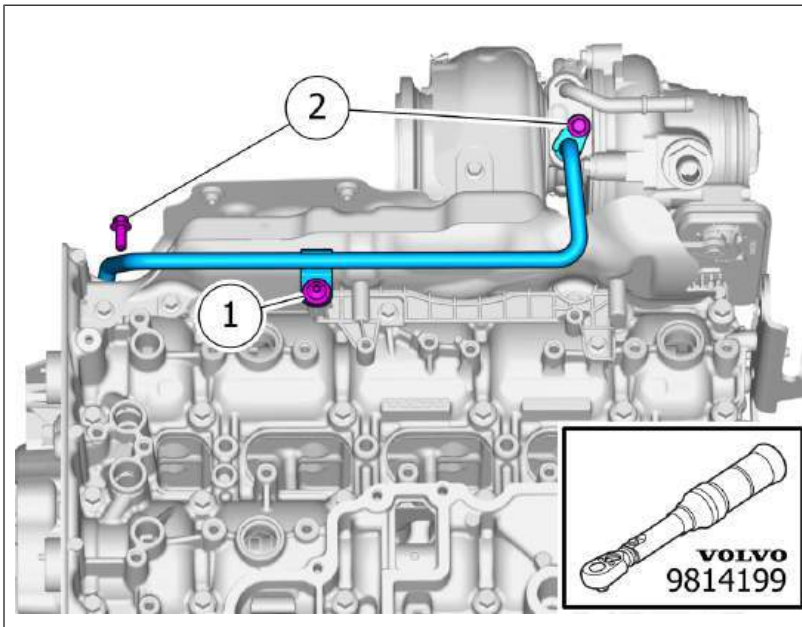

**Note! Use new seals.**

Remove the screws.  
Remove the marked part.

- 1 · **Torque:**  
M5 , 5 Nm
- 2 · **Torque:**  
M6 , 10 Nm

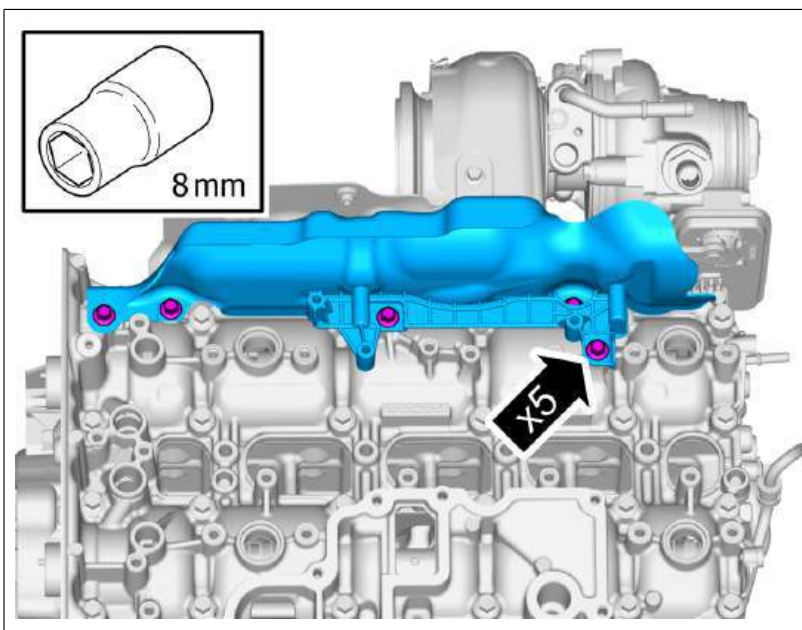

Remove the screws.  
Remove the marked part.

**Torque:**  
M6 , 10 Nm



Remove the Special Tool.

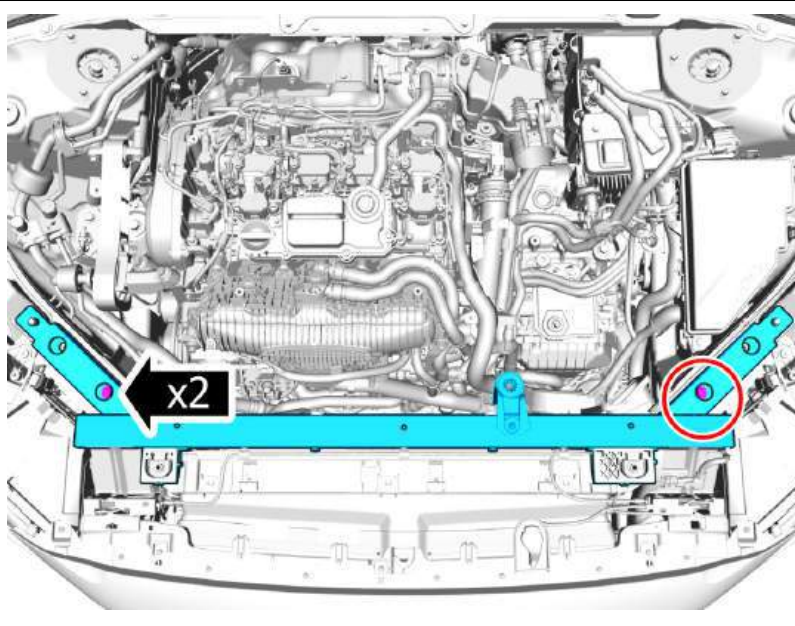

Remove the screws.  
Remove the marked part.

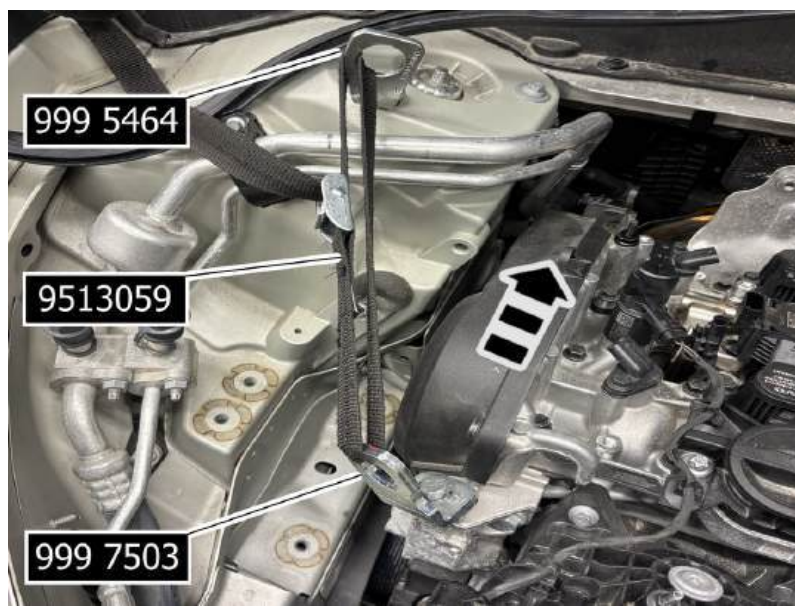

Install the Special tool.  
Pull the component in direction of the arrow.

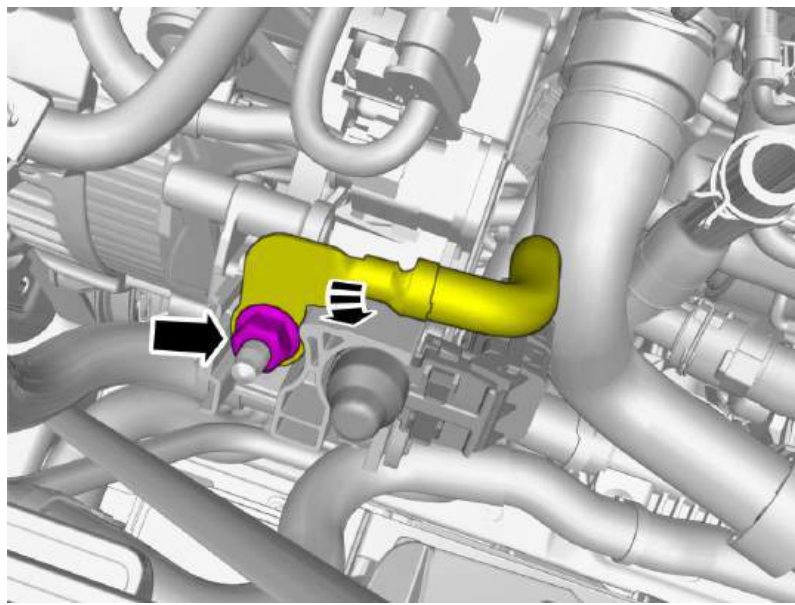

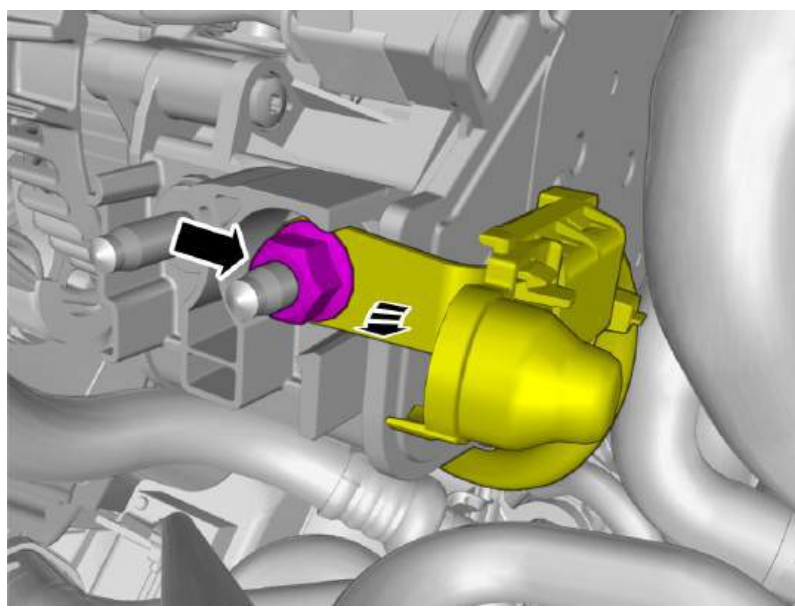

Remove the nut.

**Torque:**

M8 , 24 Nm

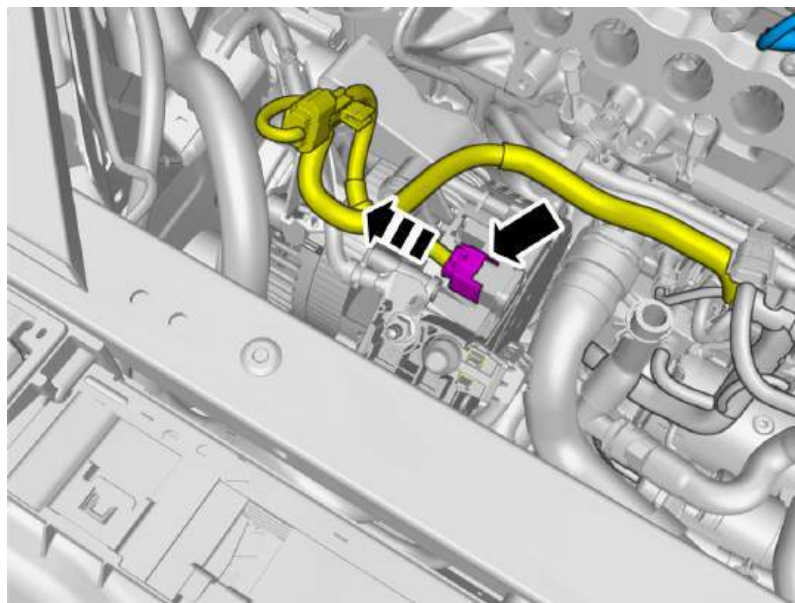

Disconnect the connector.

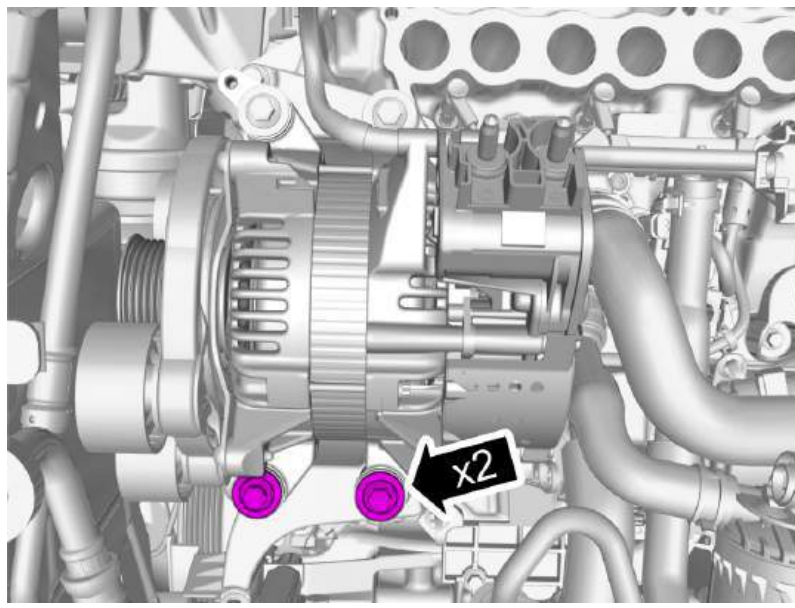

Remove the screws.

**Torque:**

M8 , 24 Nm

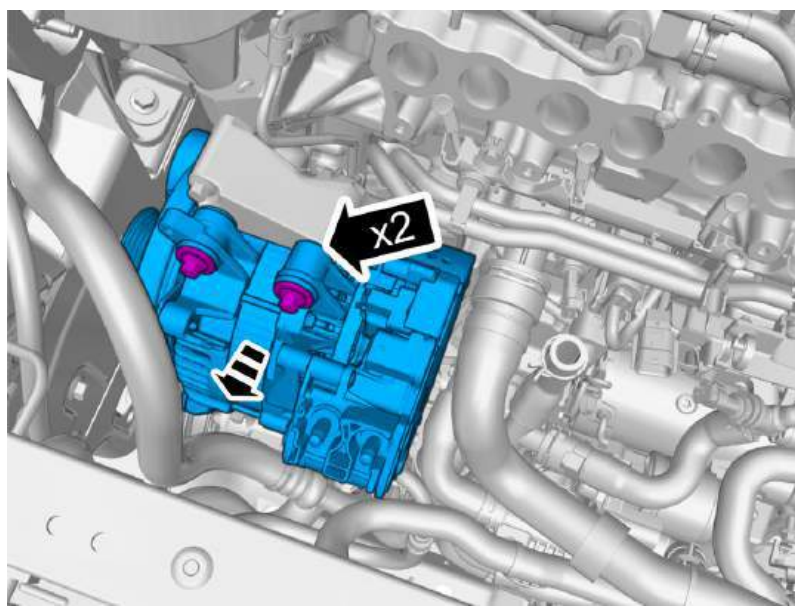

Remove the screws.

Remove the marked part.

**Hint: It may be necessary to twist or turn the component.**

**Torque:**

M8 , 24 Nm

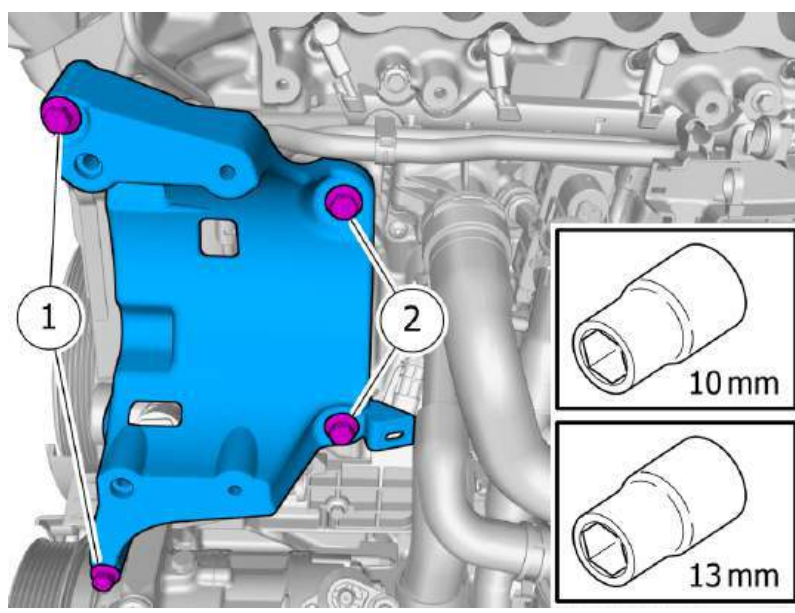

Remove the screws.  
Remove the marked part.

- 1 · **Torque:**  
M8 , 24 Nm
- 2 · **Torque:**  
M10 , 50 Nm

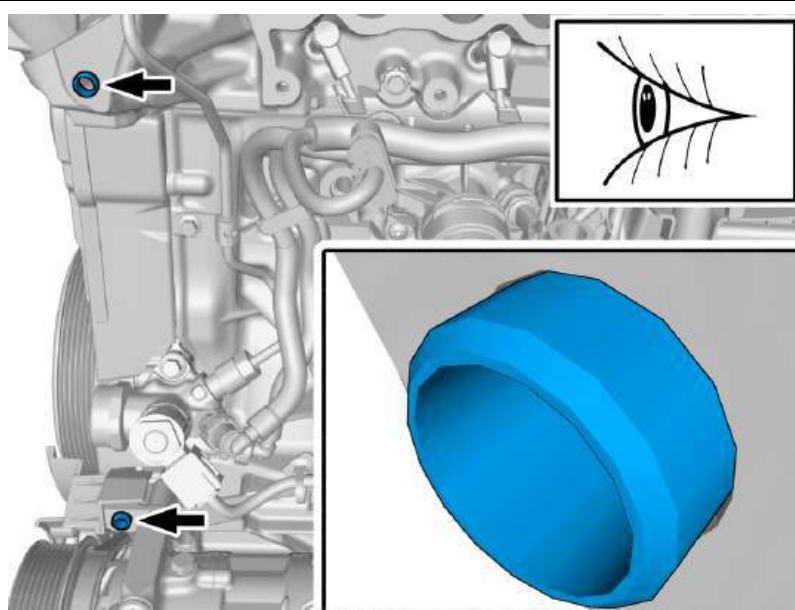

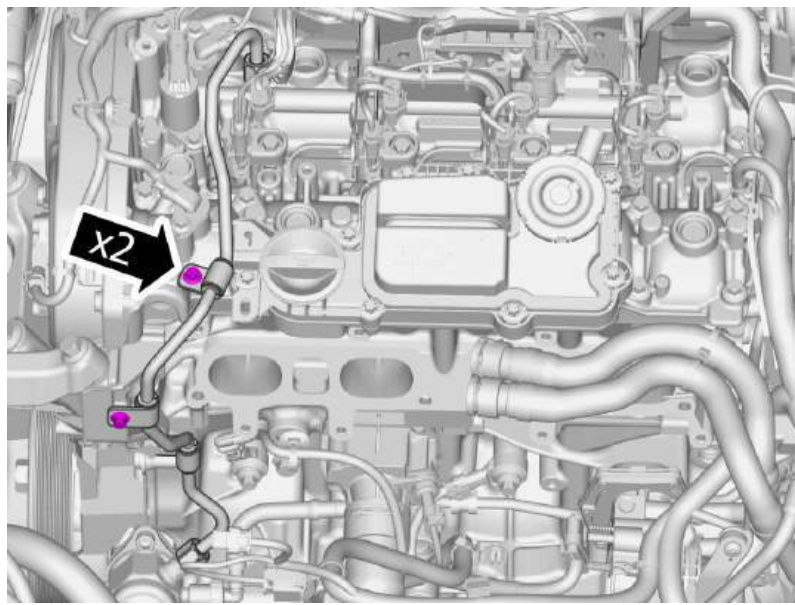

Remove the screws.

**Torque:**

M6 , 10 Nm

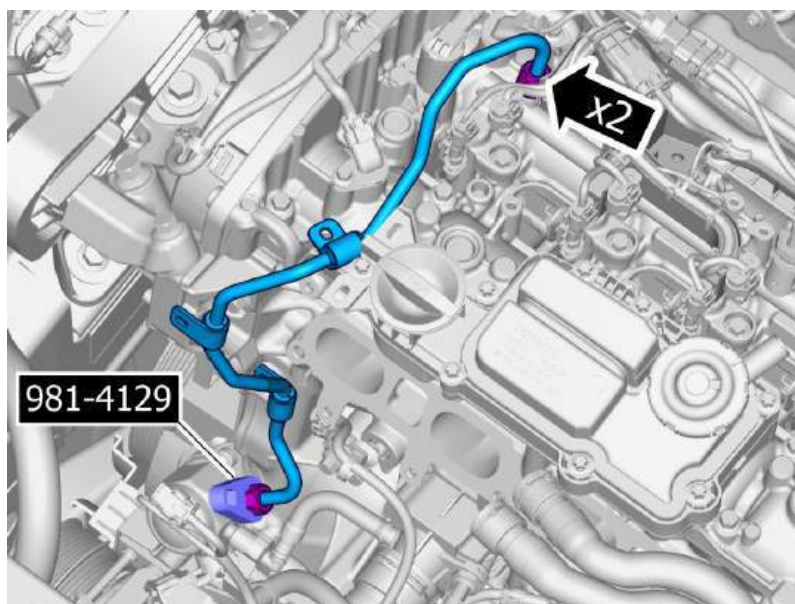

**Warning!** Be prepared to collect escaping fluid.

**Caution!** Make sure that the area around the component is clean and free of foreign material.

**Note!** Make sure that a new component is installed.

Remove the nuts.

Remove the marked part.

Special Tool: T9814129, Hook wrench

**Torque:**

- Stage 1 : High-Pressure Fuel Line to Fuel Pump , 18 Nm
- Stage 2 : High-Pressure Fuel Line to Fuel Pump , 30 Nm

Release the locks.

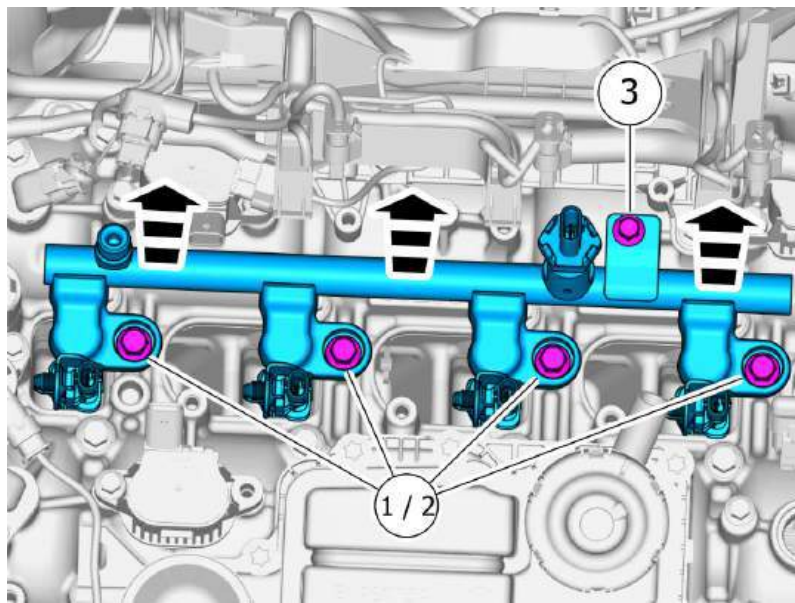
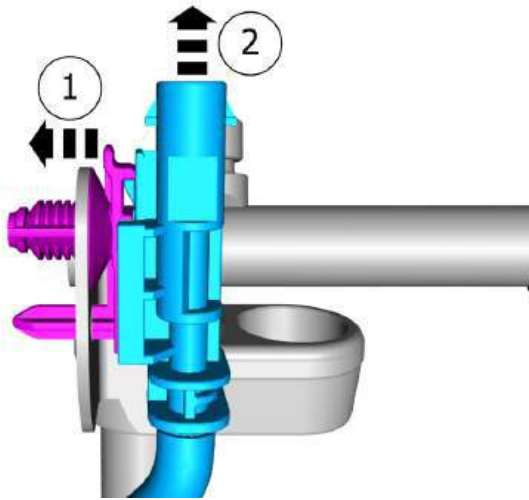

**Caution!** Make sure that the area around the component is clean and free of foreign material.

**Caution!** In order to avoid damage to the injectors, the part must be carefully pulled straight up.

**Caution!** Be extra careful when removing or installing this component.

Remove the screws.

Remove the part carefully

- 1 · **Torque:**  
Fuel rail M7 , 22 Nm
- 2 · **Torque:**  
Fuel rail M8 , 30 Nm
- 3 · **Torque:**  
M6 , 10 Nm

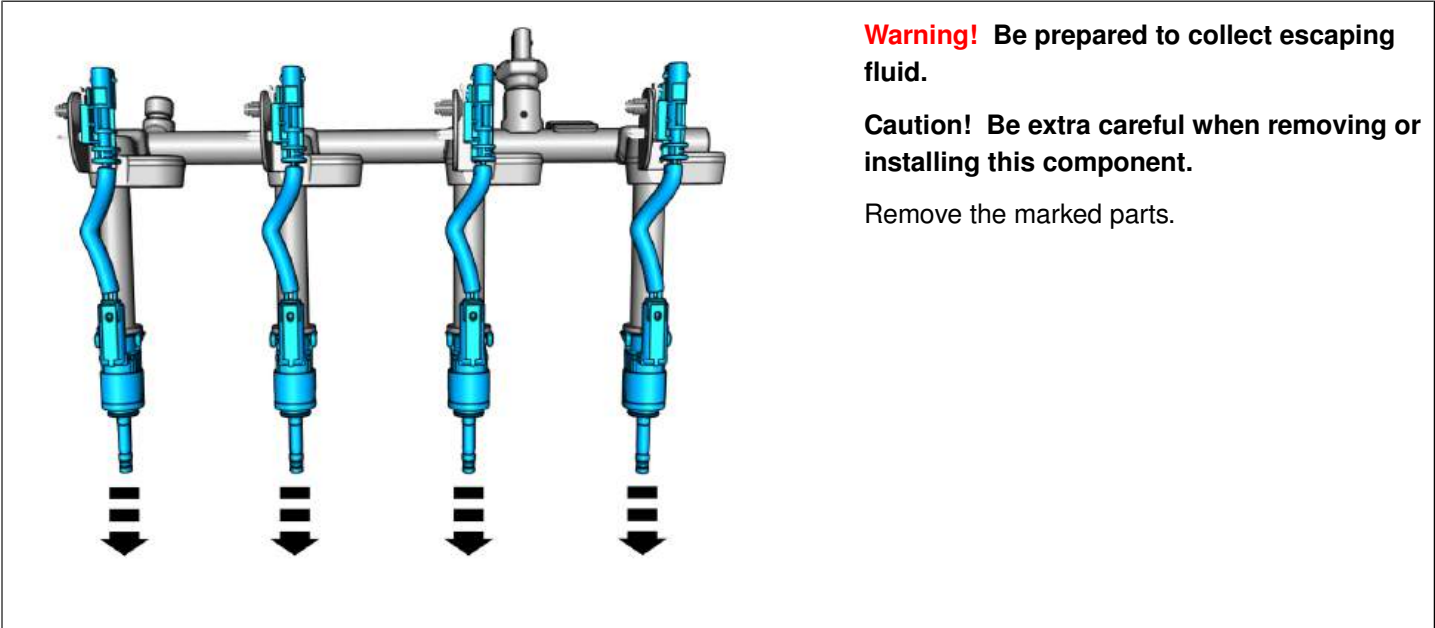

When necessary, perform the following instruction.

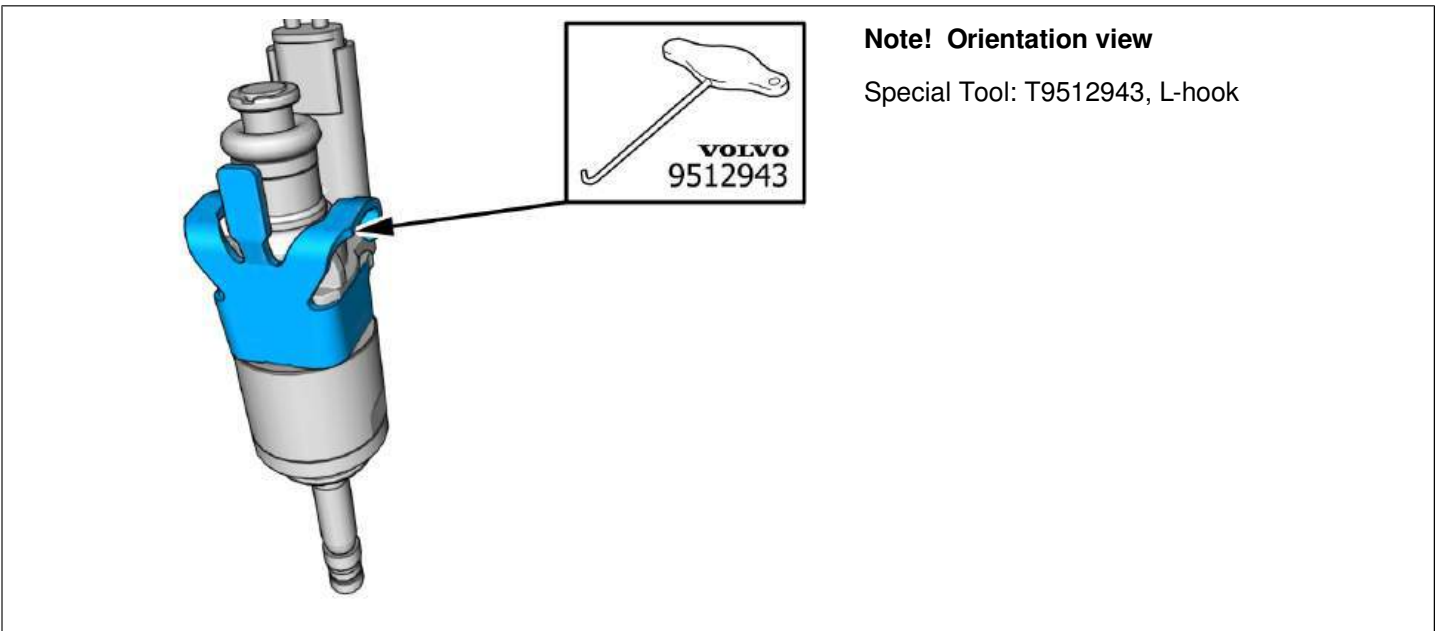

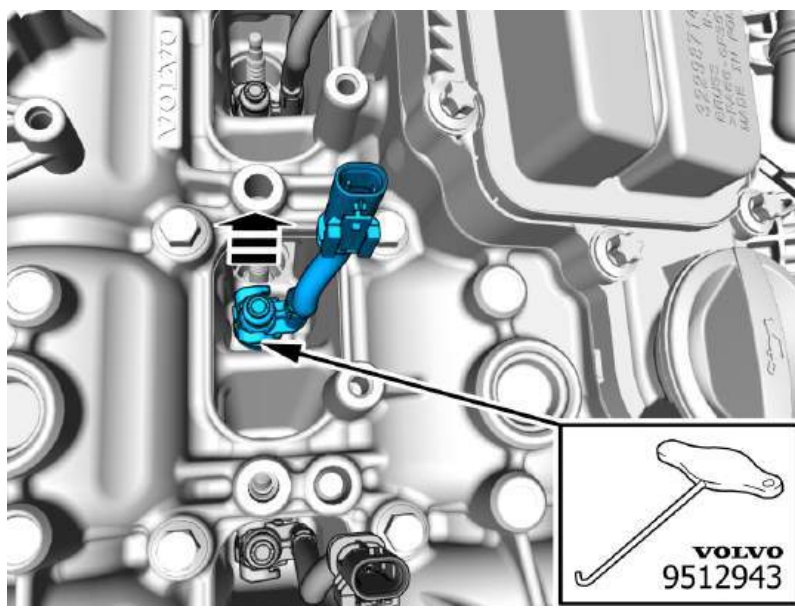

**Caution!** In order to avoid damage to the injectors, the part must be carefully pulled straight up.

**Caution!** Be extra careful when removing or installing this component.

Remove the marked part.

Special Tool: T9512943, L-hook

Replace injector seal , refer to:  
 Removal, replacement and installation  
 2 - Engine with mountings and equipment  
 23 - Fuel system  
 237 - injector and delivery pipe

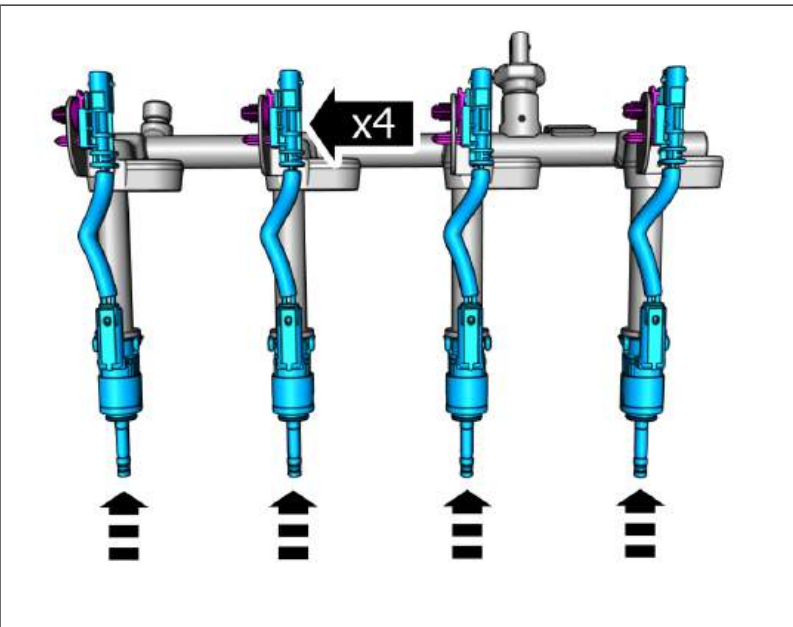

**Caution!** Be extra careful when removing or installing this component.

Install the marked components.

## Extra information

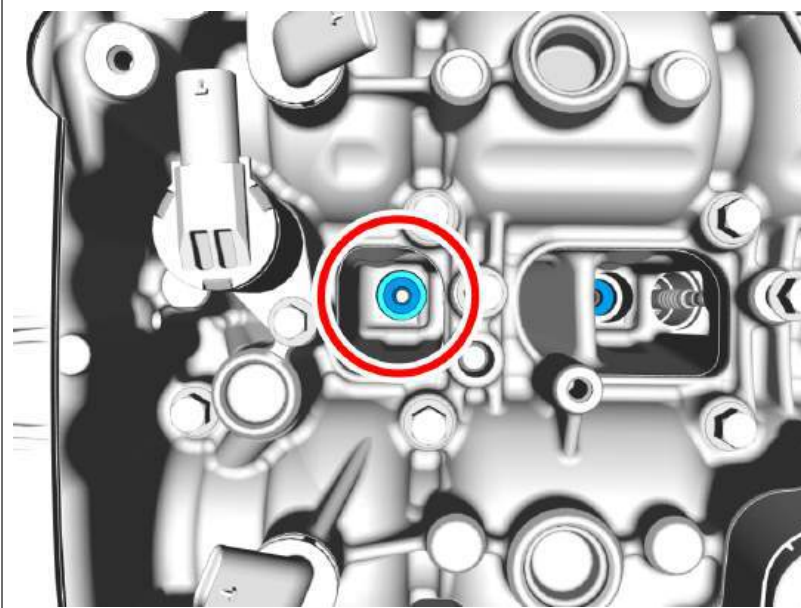

**Caution!** Make sure that the mating faces are clean and free of foreign material.

**Caution!** Clean carefully, using compressed air.

Special Tool: T9997505, Cleaning tool



Remove the Special Tool.

Applies to reassembly of the same component

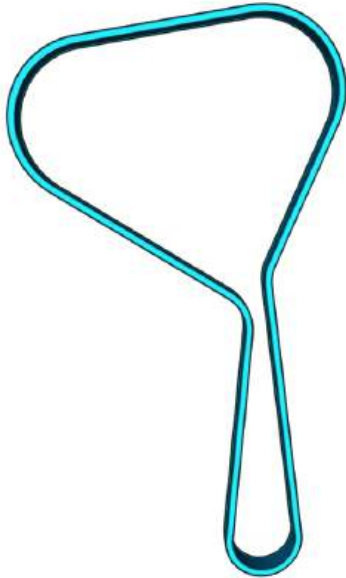

**Note!** The component can be reused unless it has been subjected to abnormal mechanical stress, damage or oil contamination.



**Caution!** The part is to be reused.

**Caution! The part is to be reused.**



**Continue the removal following the steps below.**

Remove camshaft seal , refer to:  
Removal, replacement and installation  
2 - Engine with mountings and equipment  
21 - Engine  
215 - transmission

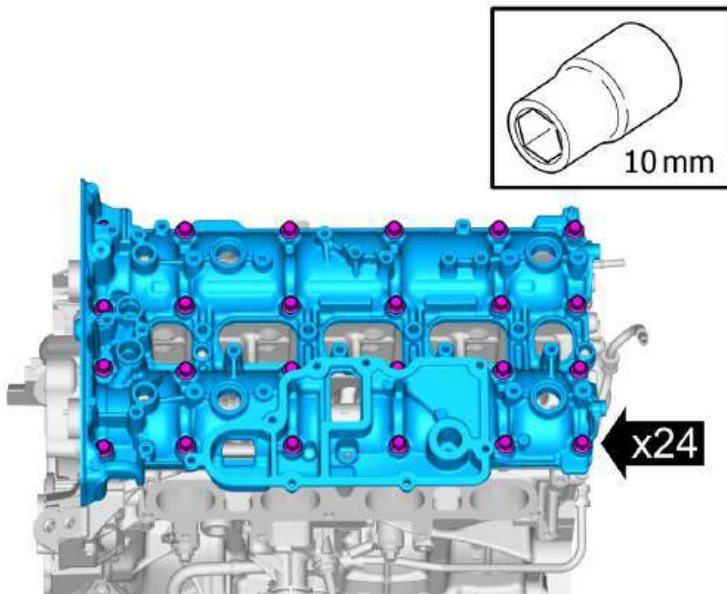

Loosen each bolt 2 turns at a time until all bolts are removed.  
Remove the marked part.

Vehicles early version

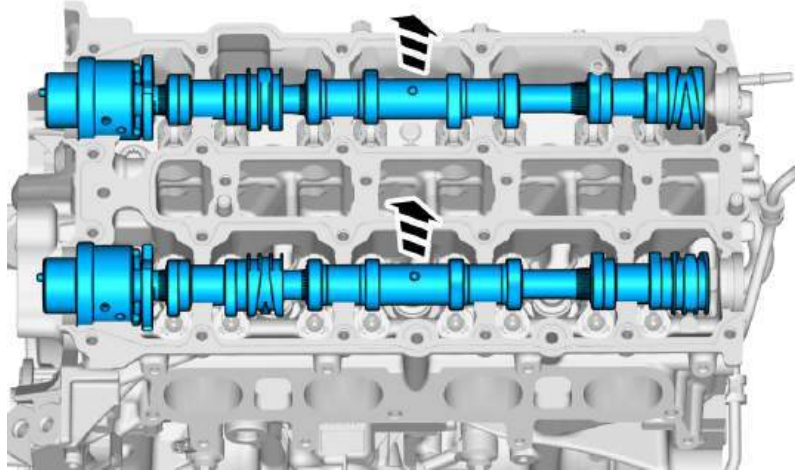

**Caution! Note the location of the component before removal.**

**Caution! Take extra care when handling the components.**

Remove the marked parts.

Vehicles late version

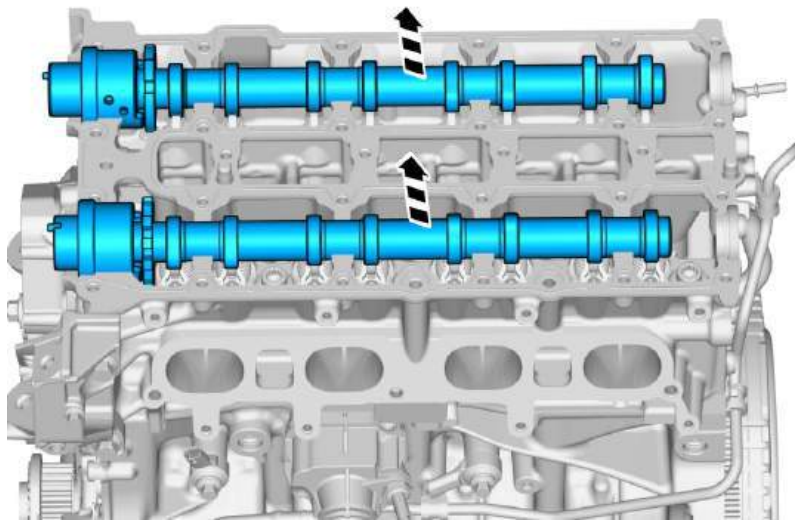

**Caution! Note the location of the component before removal.**

**Caution! Take extra care when handling the component.**

Remove the marked parts.

## Cleaning

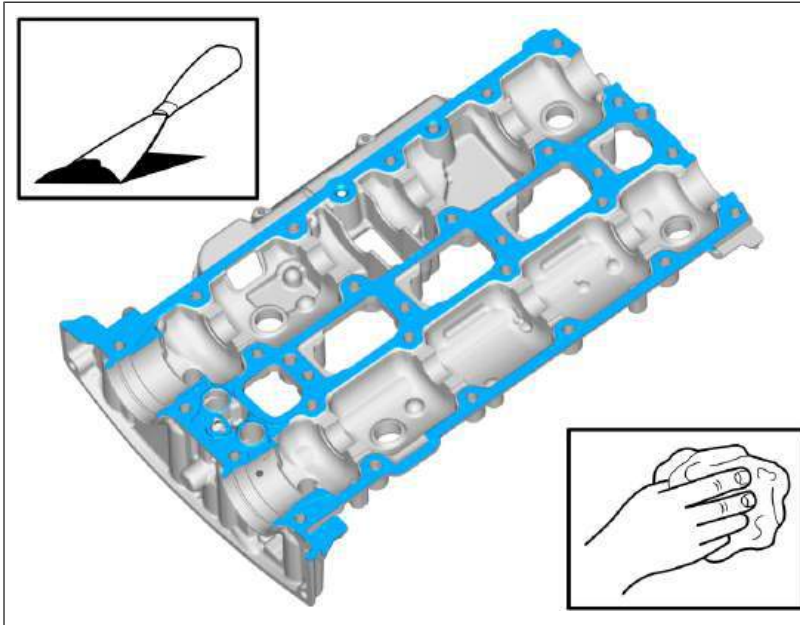

**Caution!** Take extra care not to damage the mating faces.

**Caution!** Make sure that the oil galleries are clean and free of foreign material.

**Note!** Make sure that the mating faces are clean and free of foreign material.

**Use:** Putty knife (plastic)

**Use:** Abrasive cloth

**Use:** Isopropanol ,

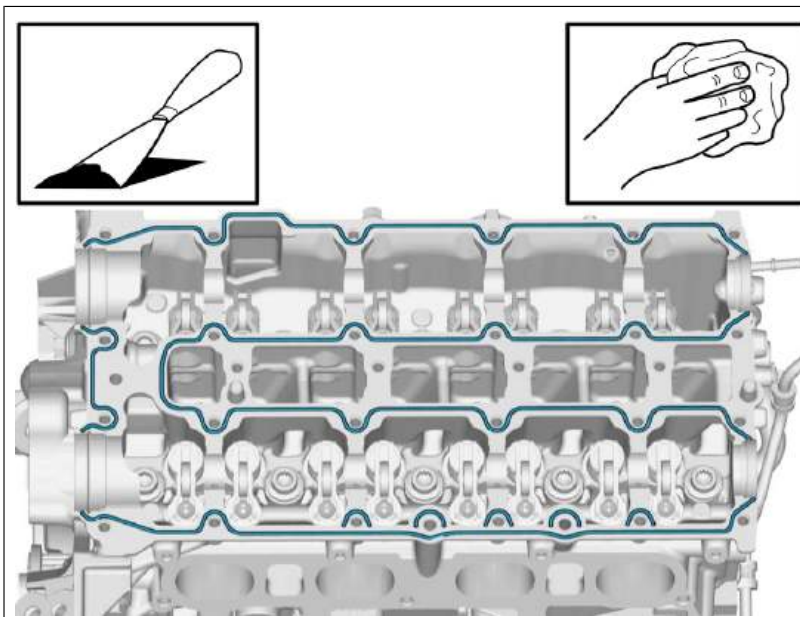

**Caution!** Take extra care not to damage the mating faces.

**Caution!** Make sure that the oil galleries are clean and free of foreign material.

**Note!** Make sure that the mating faces are clean and free of foreign material.

**Use:** Putty knife (plastic)

**Use:** Abrasive cloth

**Use:** Isopropanol ,

### Installation

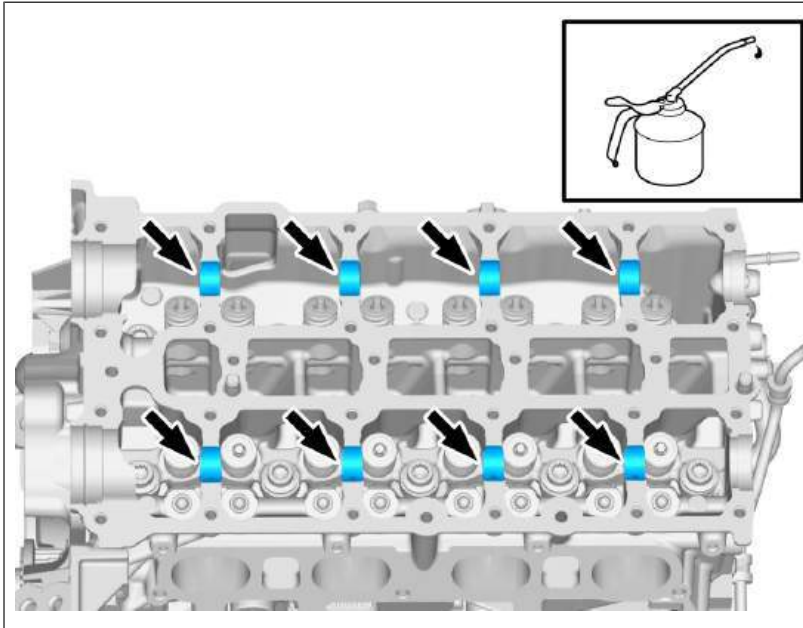

**Use:** Engine oil ,

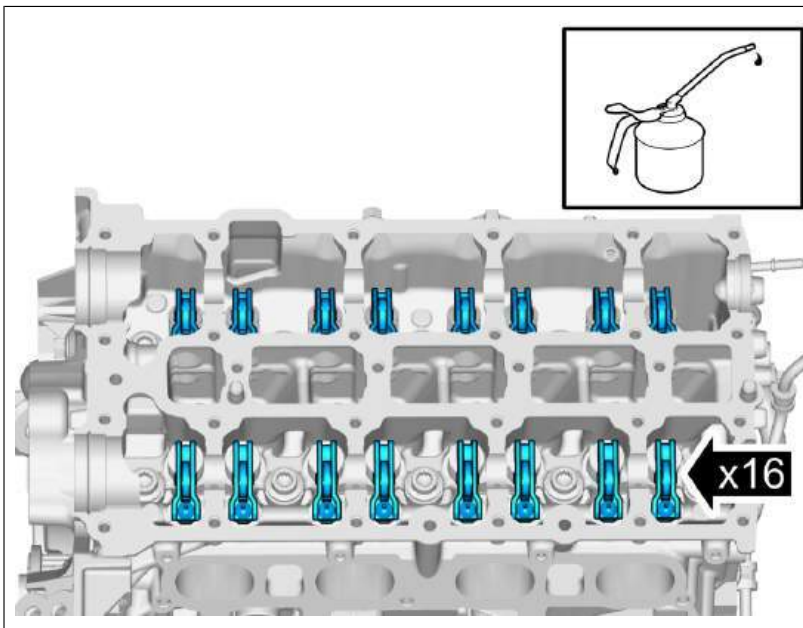

**Use:** Engine oil ,

Vehicles early version

**Caution! Make sure that the components are positioned correctly.**

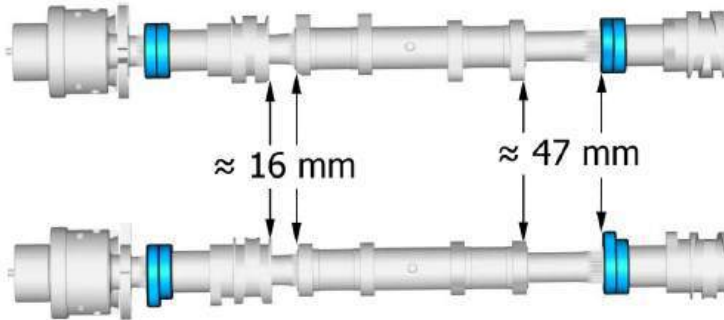

**Caution! Make sure that the components are positioned correctly.**

Install the marked components.

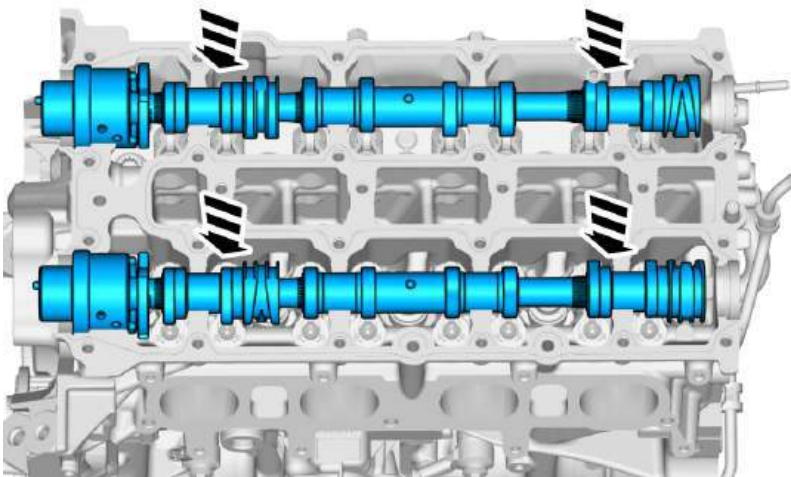

Vehicles late version

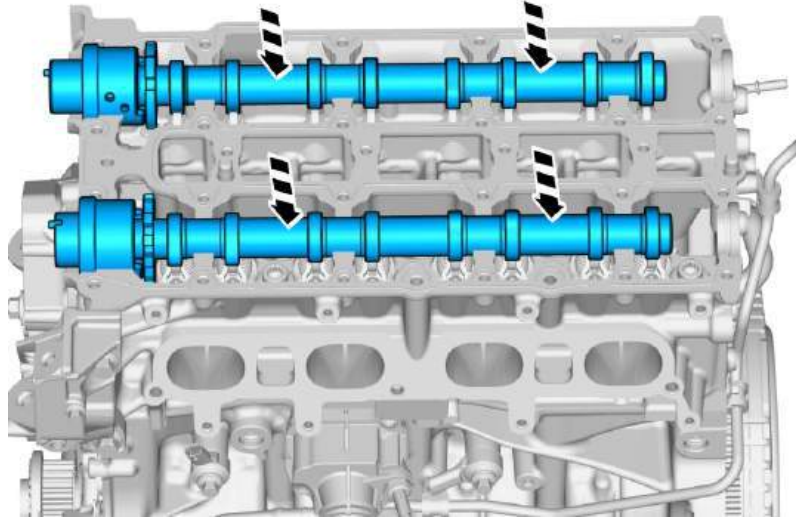

**Caution! Make sure that the components are positioned correctly.**

Install the marked components.

All vehicles

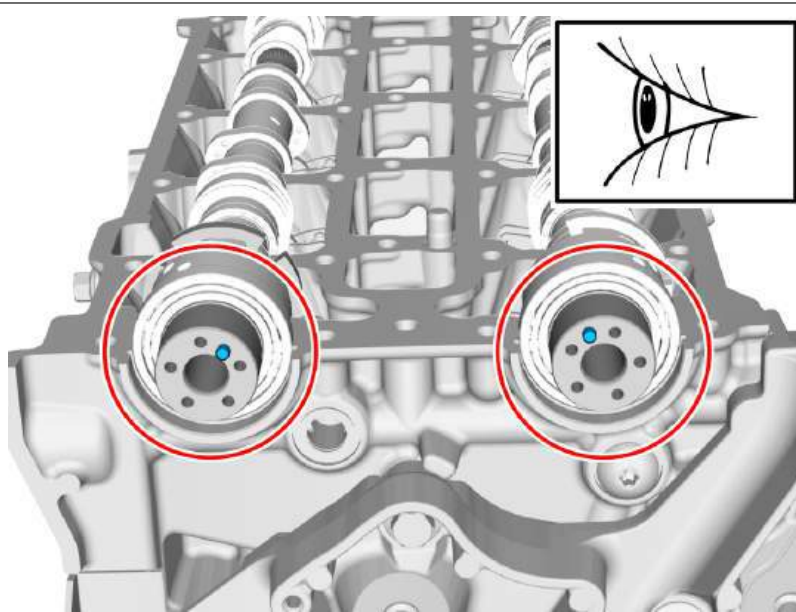

**Caution! Make sure that the components are positioned correctly.**

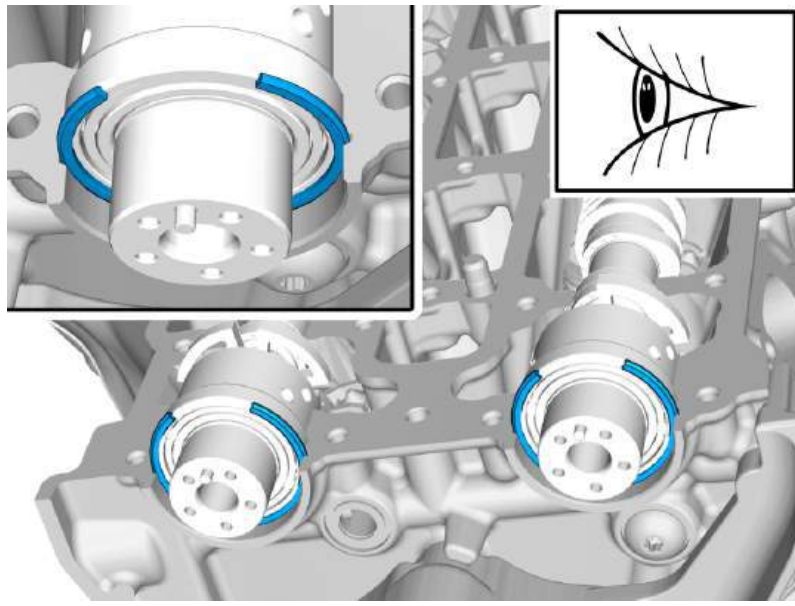

**Caution! Make sure that the components are positioned correctly.**

Install the marked components.

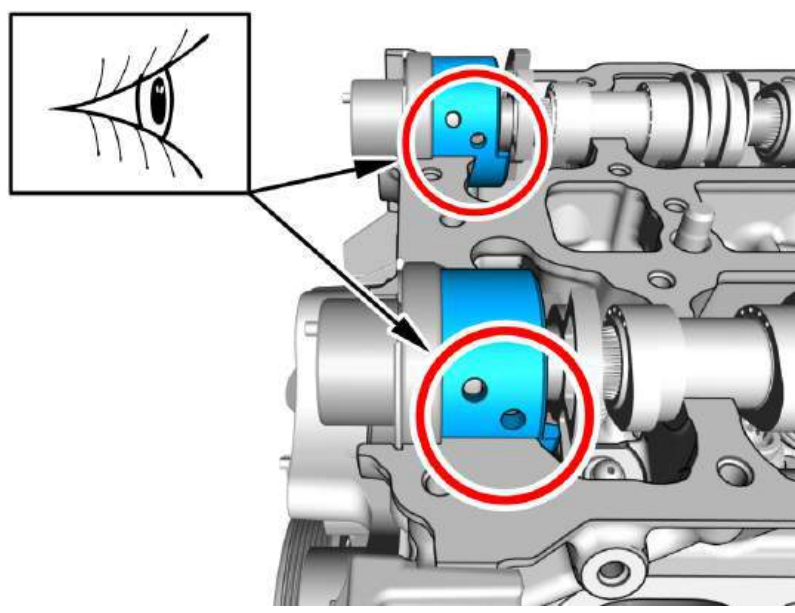

**Caution! Make sure that the components are positioned correctly.**

All vehicles

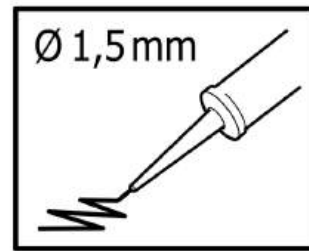
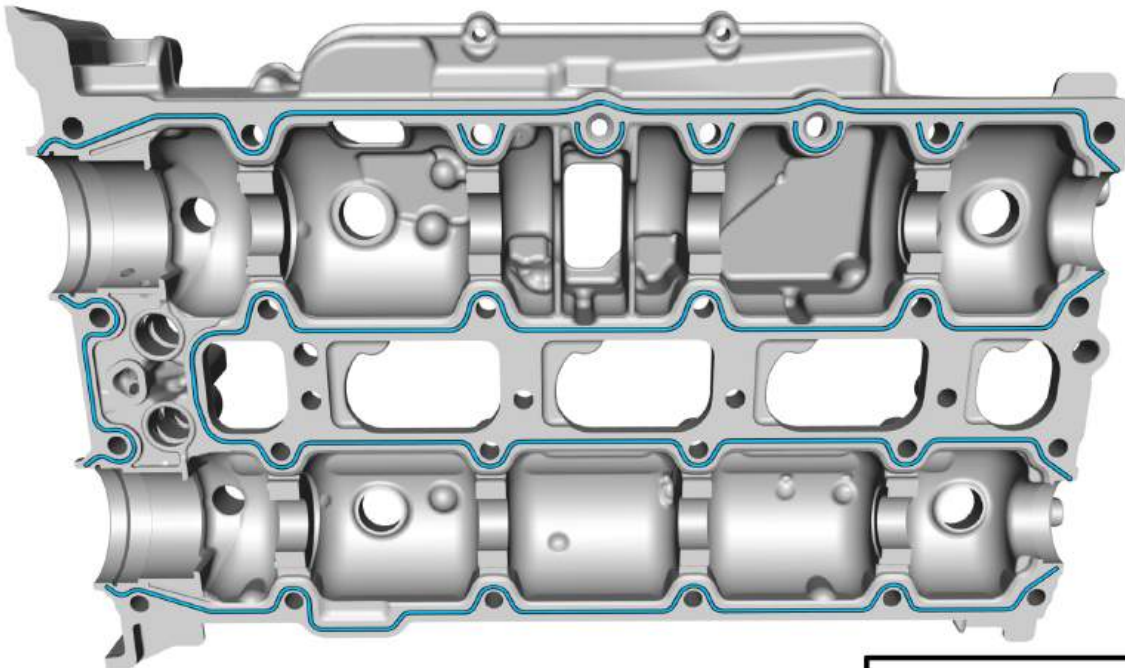

**Note!** The component must be installed within 5 minutes of applying the sealant.

**Use:** Chemical gasket , 1161771

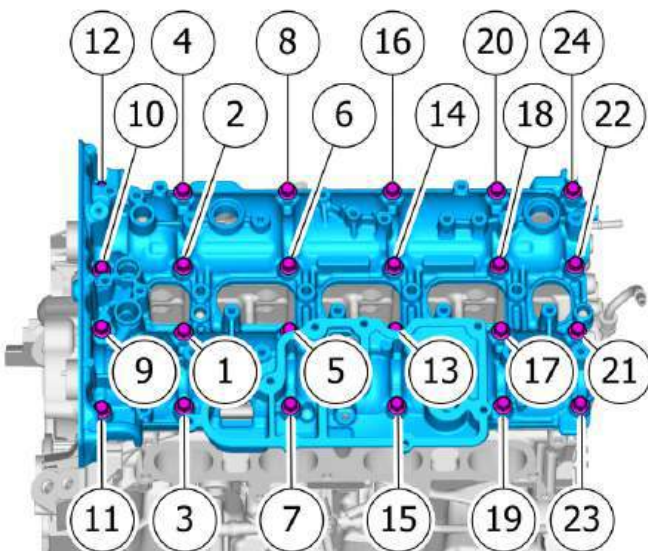

**Caution!** Make sure that equal pressure is applied to the full length of the component.

**Note!** Make sure to follow the sequence indicated.

Install the marked component.  
Install the screws.  
Tighten each bolt 2 turns at a time.

**Torque:**

M7 , 17 Nm

To install, reverse the removal procedure.

**Check**

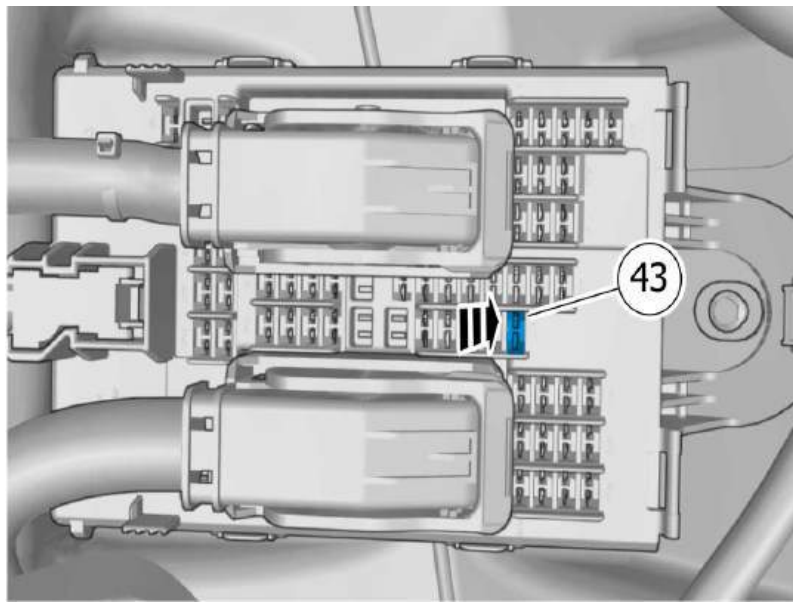

Reinstall the fuse.  
Start the engine.

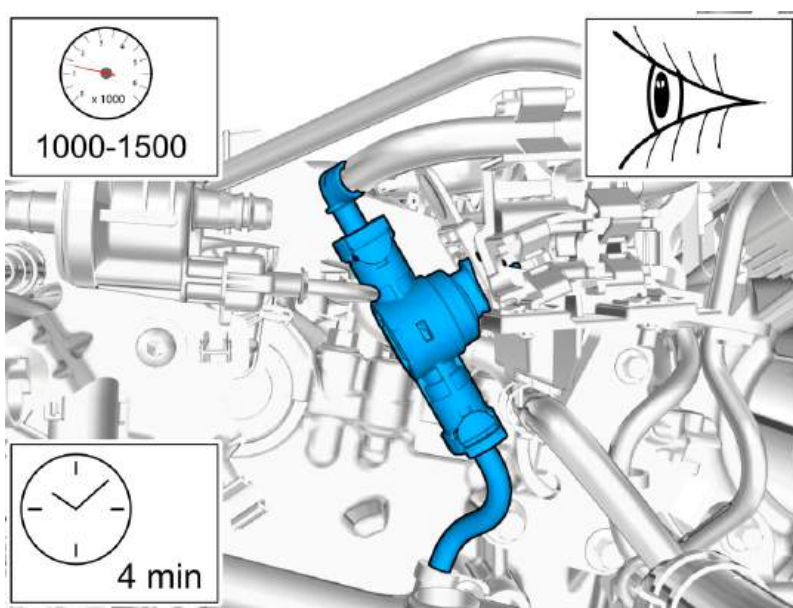

**Warning!** Make sure that there are no leaks.

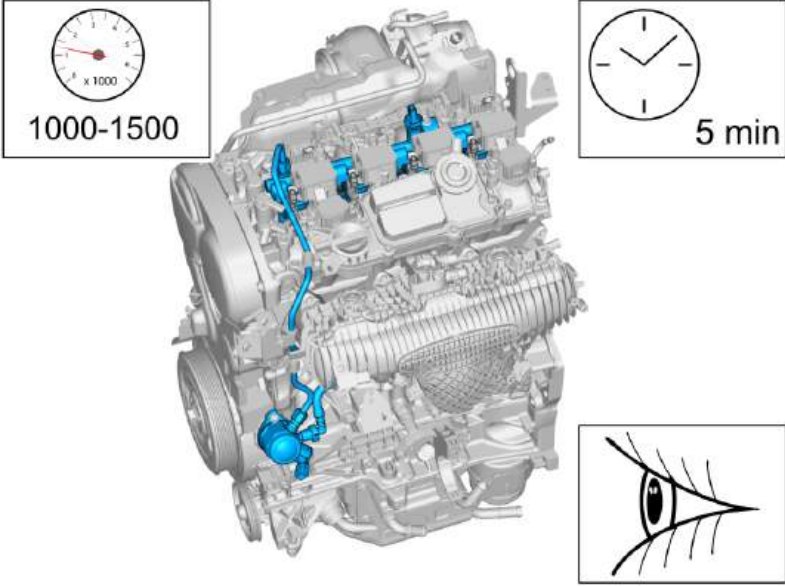

**Warning!** Make sure that there are no leaks.

The diagram shows a 3D cutaway view of an engine with blue hoses. To the left is a tachometer icon with a needle pointing to 1000-1500 RPM (x 1000). To the right is a clock icon labeled '5 min'. Below the engine is an icon of an eye, indicating a safety warning.

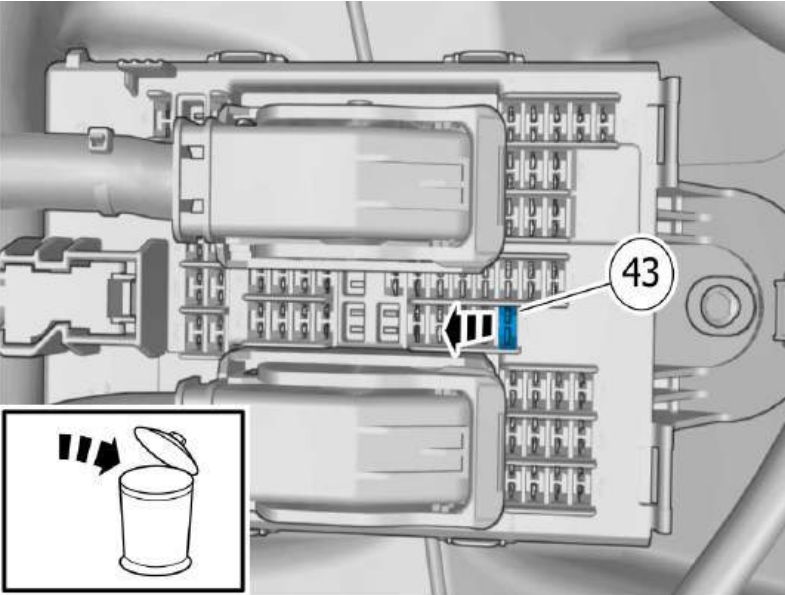

Switch off the engine.  
Discard of the previously installed fuse and install a new one.

The diagram shows a fuse box with a callout '43' pointing to a specific fuse. An inset icon shows a fuse being discarded into a trash bin.



## Volvo Car Customer Service

TJ Instruction VCC-531608-2

|               |                  |                          |          |
|---------------|------------------|--------------------------|----------|
| <b>Title</b>  | Camshaft bushing | <b>Page</b>              | 1 ( 60 ) |
| <b>Action</b> | Replacement      | <b>Operation number:</b> | 98783-2  |

| <b>Issue</b> | <b>Date</b> | <b>Reason</b>               |
|--------------|-------------|-----------------------------|
| 1            | 2025-03     | First issue                 |
| 2            | 2025-11     | Change in Affected Vehicles |

### Affected vehicles

| <b>Model year</b>                        | <b>Model</b> | <b>Engine</b>                  |
|--|--------------|--------------------------------|
| 2021, 2022,<br>2023, 2024,<br>2025, 2026 | EX40 / XC40  | B420T10, T2, T4, T5,<br>T6, T8 |

### Materials

| <b>Materials</b> | <b>Qty.</b> | <b>Part No.</b> | <b>Notes</b> |
|------------------|-------------|-----------------|--------------|
| Abrasive cloth   | 2           | 9511024         |              |
| Isopropanol      | 2           |                 |              |
| Chemical gasket  | 1.0         | 1161771         |              |

### Special tools

| <b>Description</b> | <b>Part No.</b> |
|--------------------|-----------------|
| Support            | 999 7680        |
| Counterhold        | 999 7718        |
| Hook wrench        | 981 4129        |
| L-hook             | 951 2943        |
| Cleaning tool      | 999 7505        |

### Equipment

| <b>Designation</b>    | <b>Part No.</b> |
|-----------------------|-----------------|
| Putty knife (plastic) |                 |

## Removal

**Note! Removal steps in this procedure may contain installation details.**

Illustrations in the information may be reused from previous models and may therefore deviate as regards the background's motif. The technical content relevant to the operation is, however, always correct.

See information on safety information fuel system , refer to:

- General Safety Information
- 2 - Engine with mountings and equipment
- 23 - Fuel system
- 230 - general

Inactive

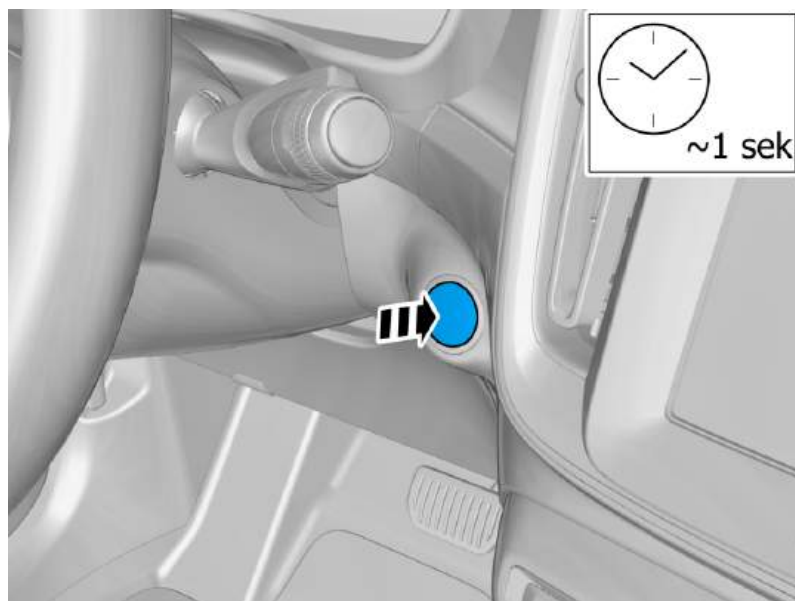

Functional availability is limited.

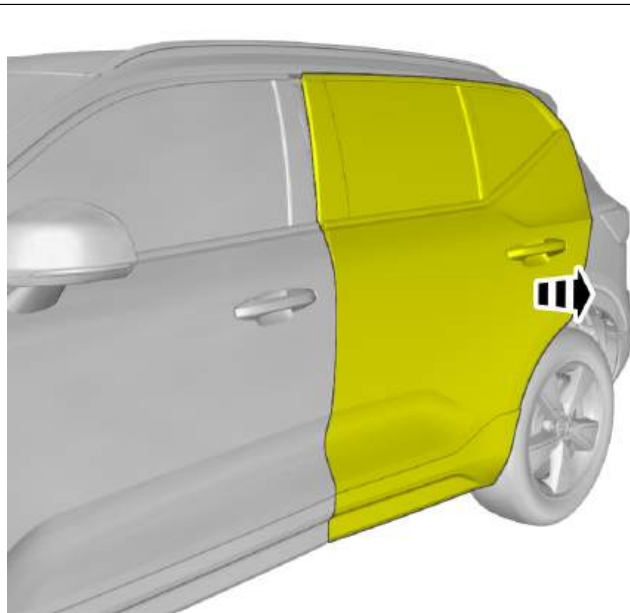
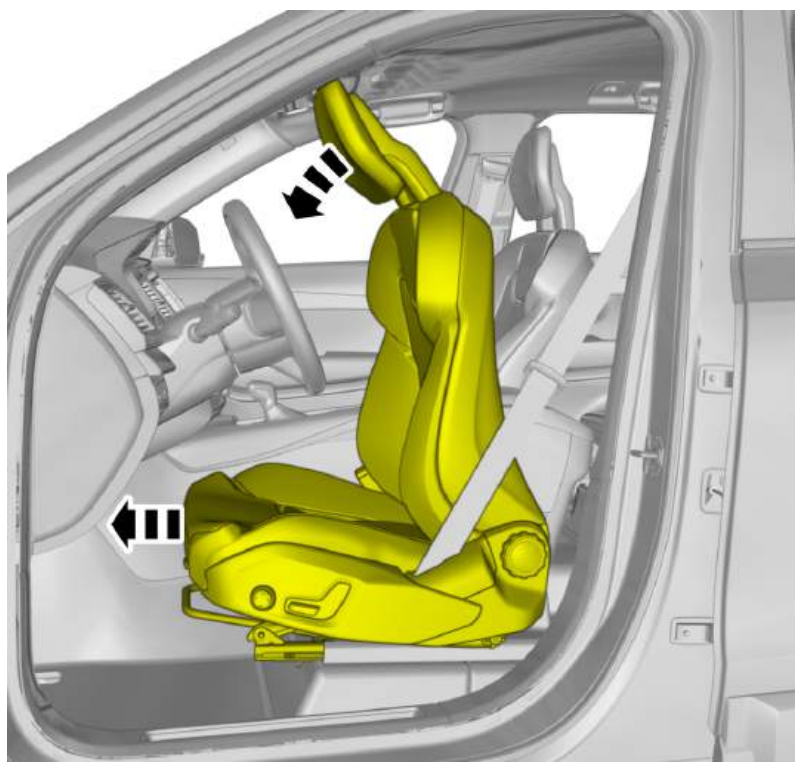

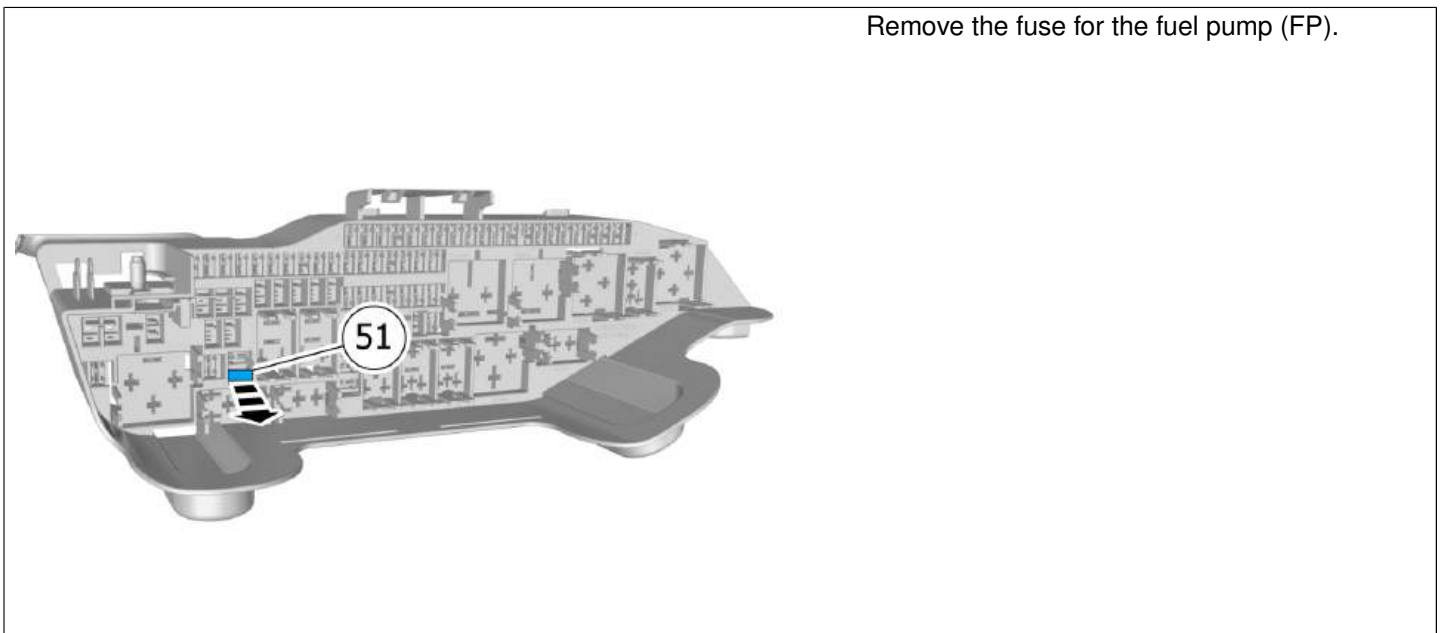
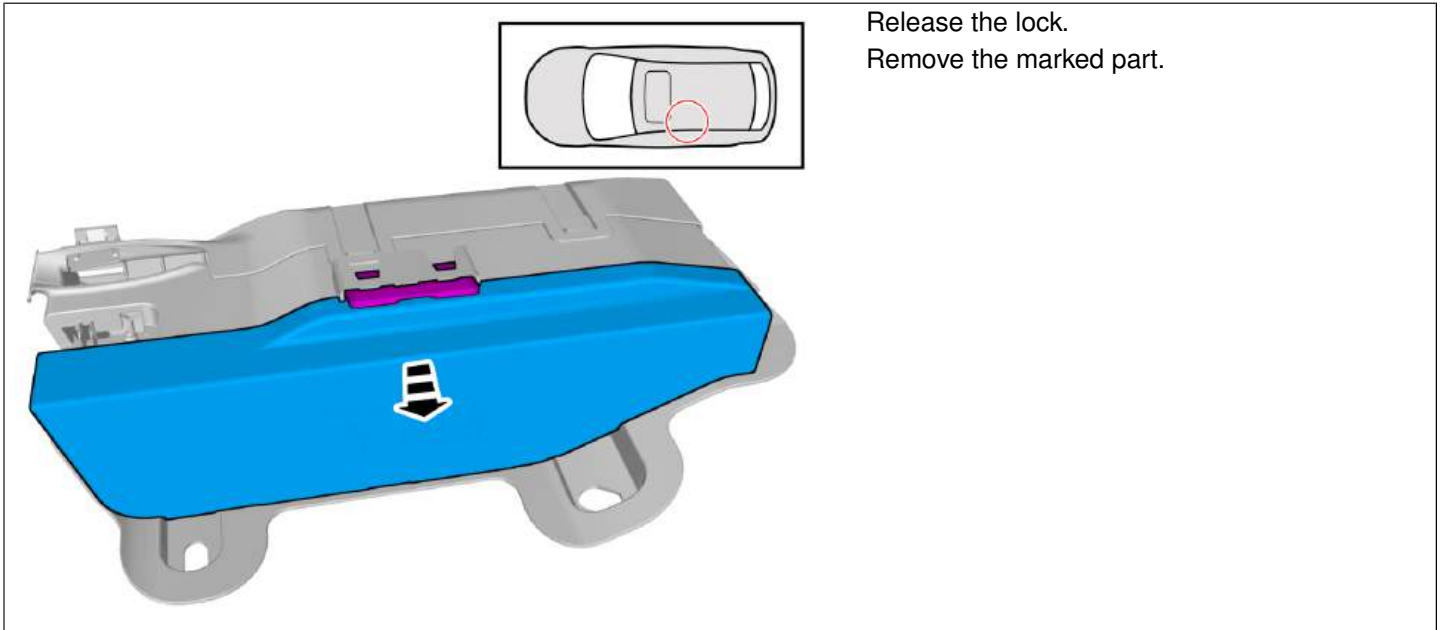

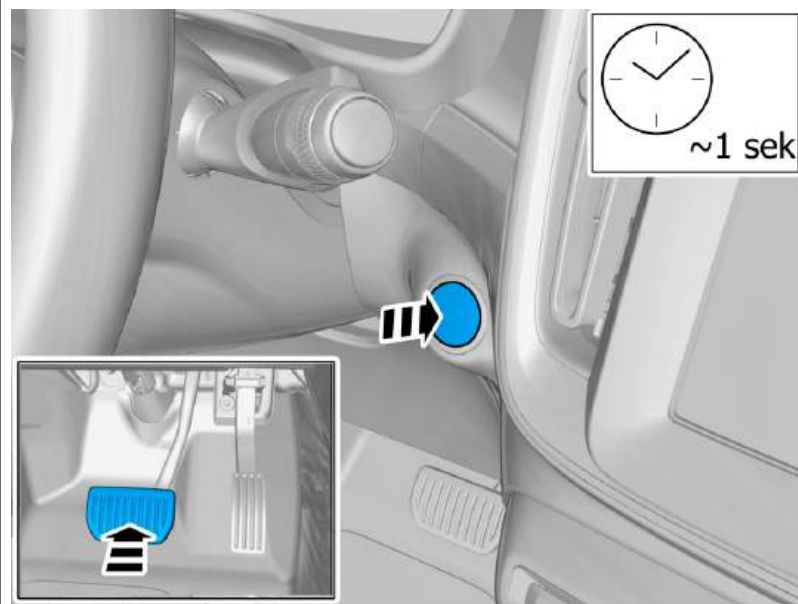
**Activation**

Start and run the engine at idle until it stops.

Perform mid voltage battery, disconnecting and connecting , refer to:

- Cleaning, Inspection and Adjustment
- 3 - Electrical system
- 31 - Battery and mounting
- 311 - battery

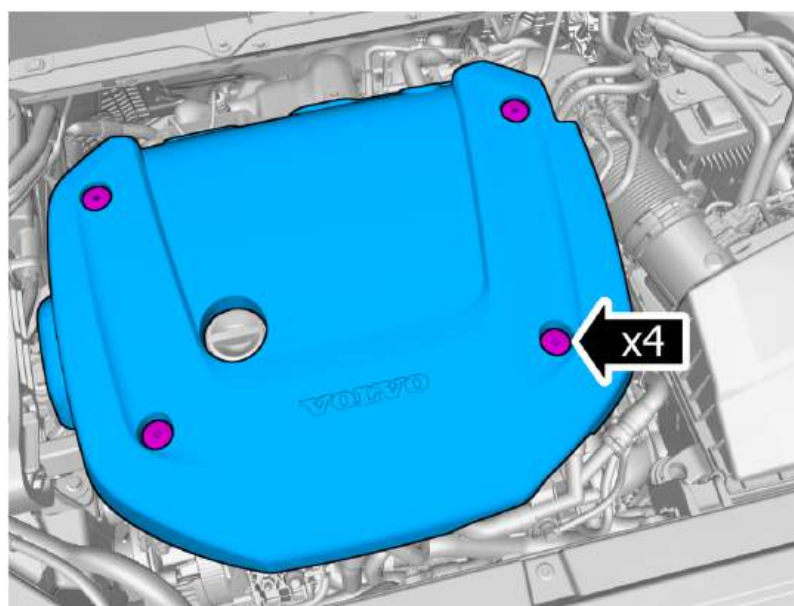

Loosen the screws.  
Remove the marked part.

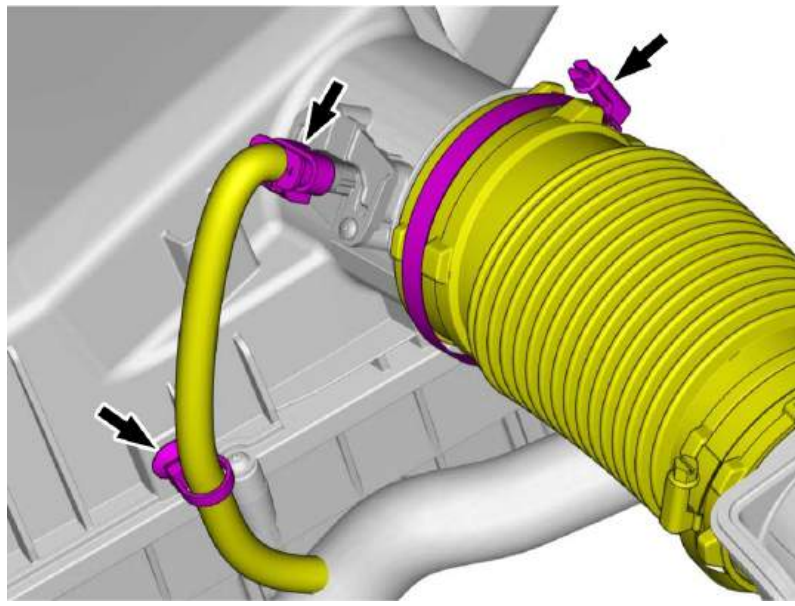

Disconnect the connector.  
Loosen the clips.  
Loosen the hose clamp.

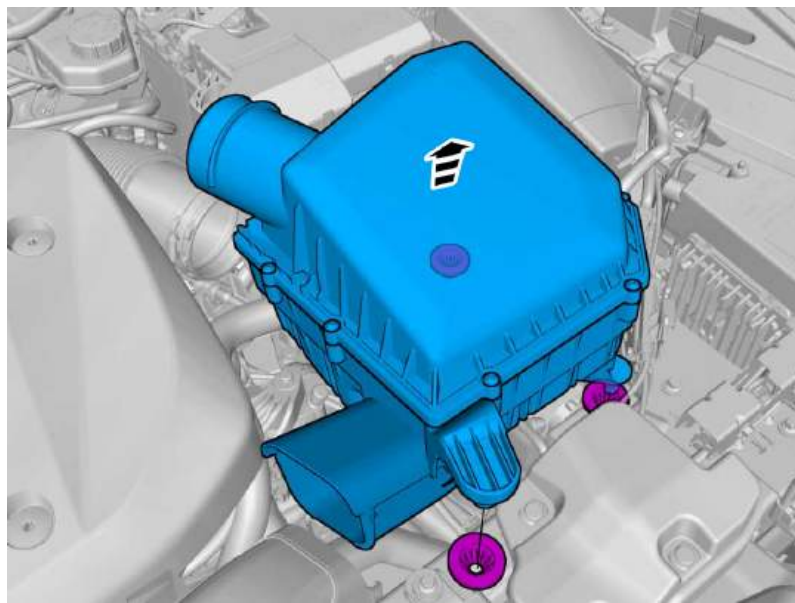

Remove the marked part.

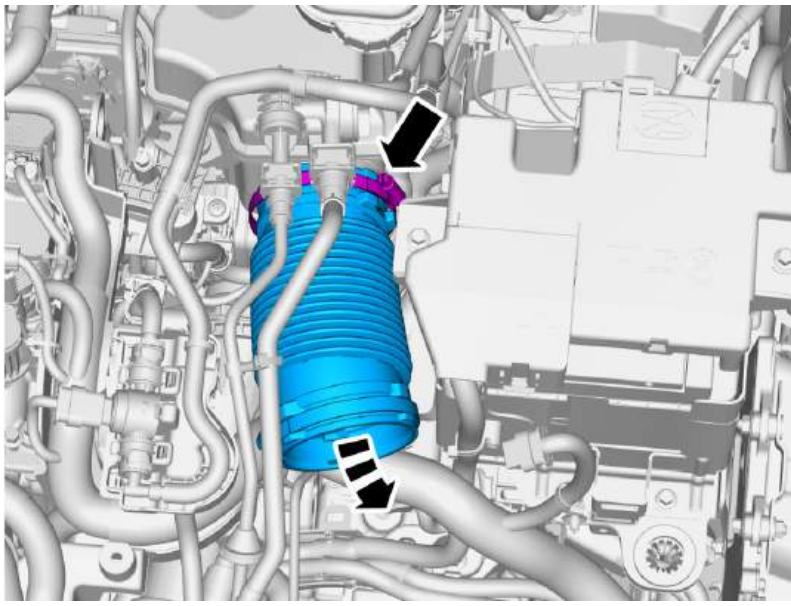

Loosen the hose clamp.  
Remove the marked part.

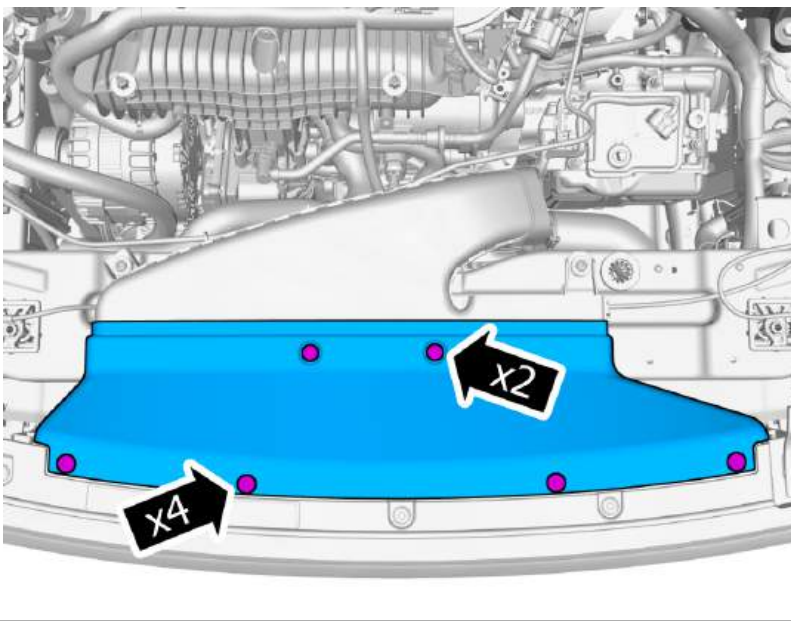

Remove the clips.  
Remove the marked part.

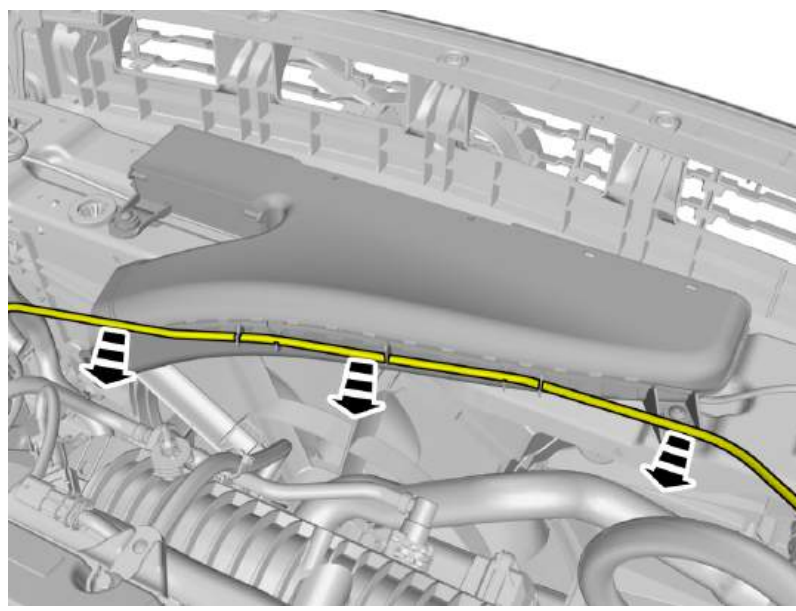

Fold marked part aside.

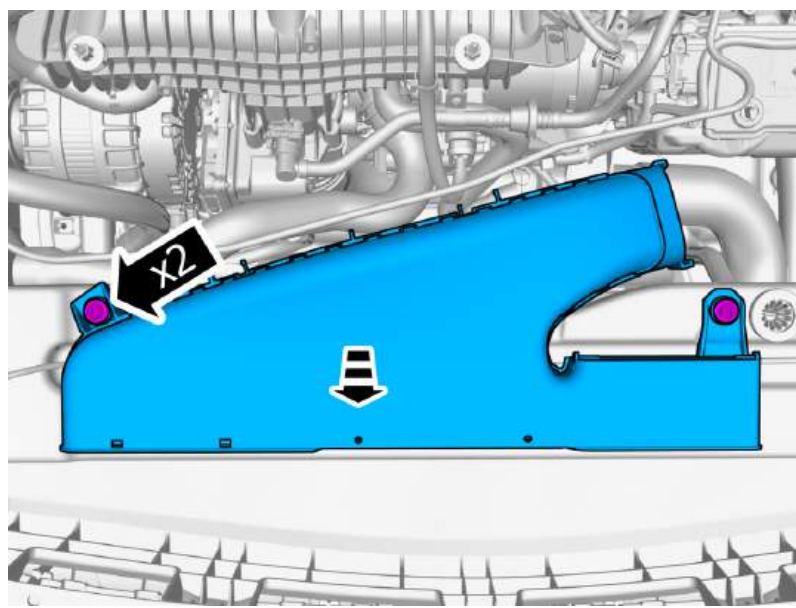

Remove the screws.  
Remove the marked part.

**Torque:**

Air deflector to upper radiator member ,  
5 Nm

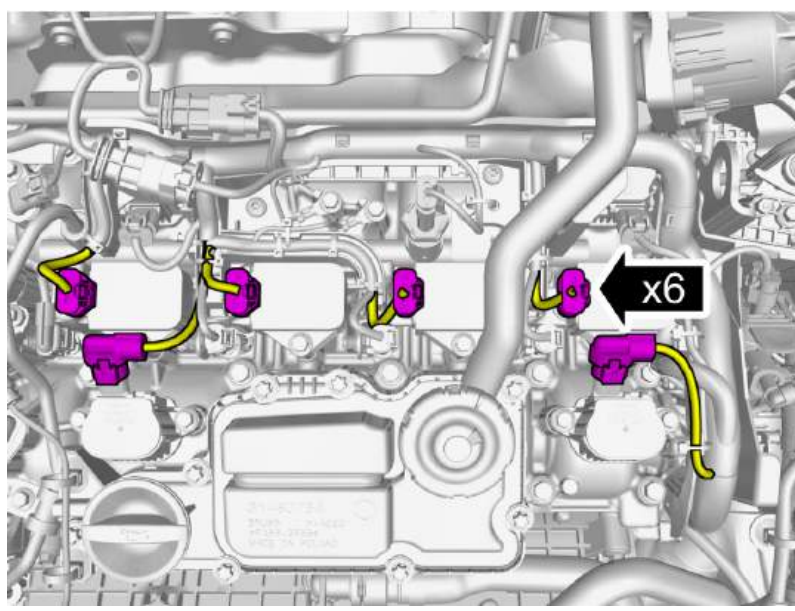

Disconnect the connectors.

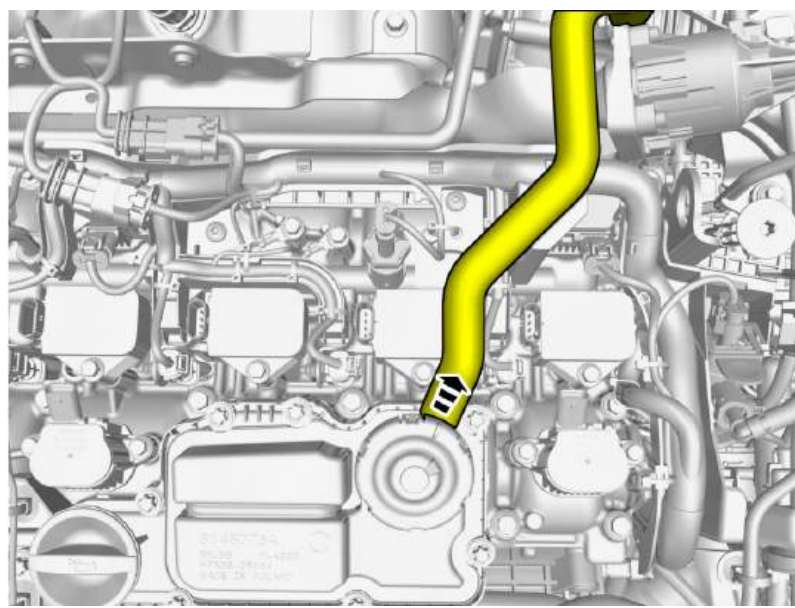

Undo the hose from the connection.

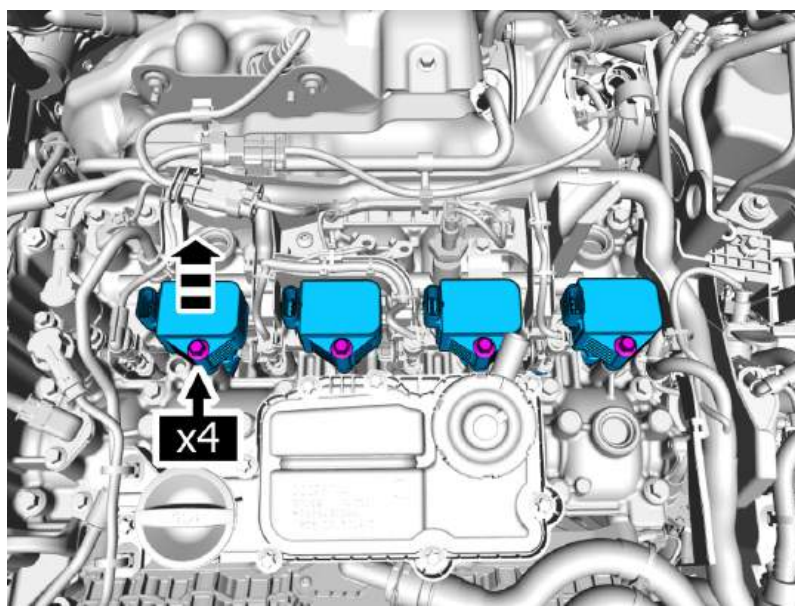

Remove the screws.  
Remove the marked parts.

**Torque:**  
M6 , 10 Nm

**Installation**

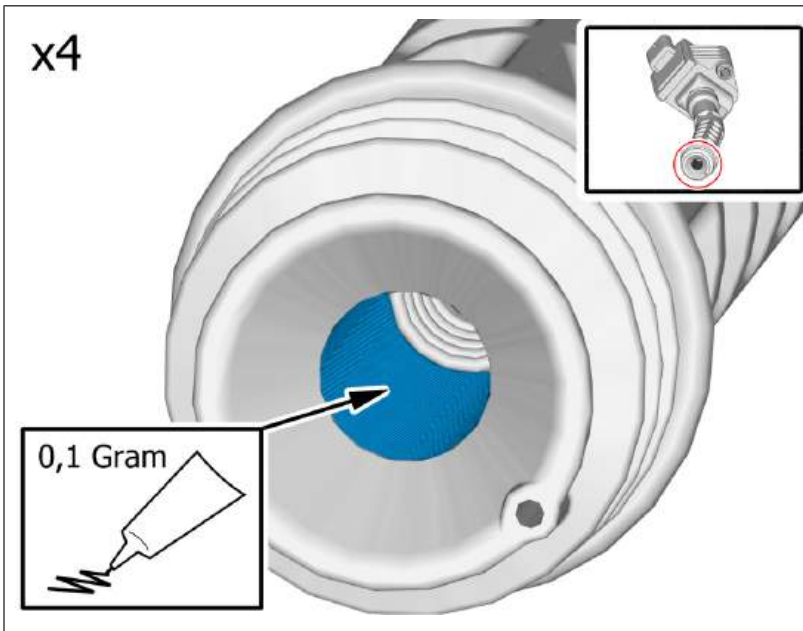

Apply grease on the area indicated.

Continue the removal following the steps below.

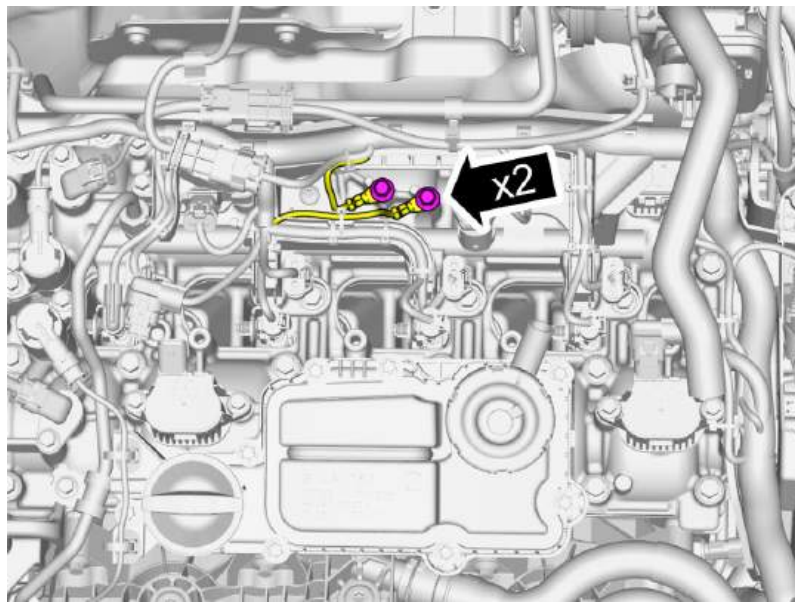

Remove the screws.

**Torque:**

M6 , 10 Nm

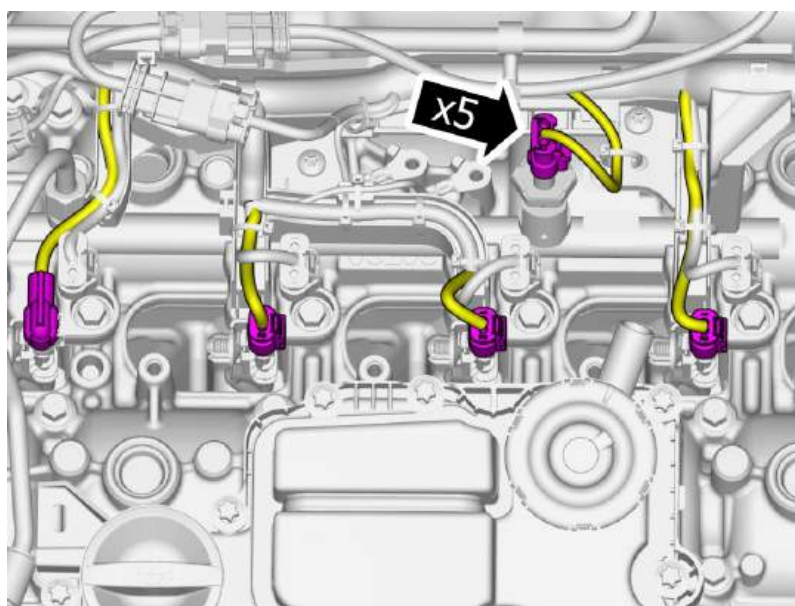

Disconnect the connectors.

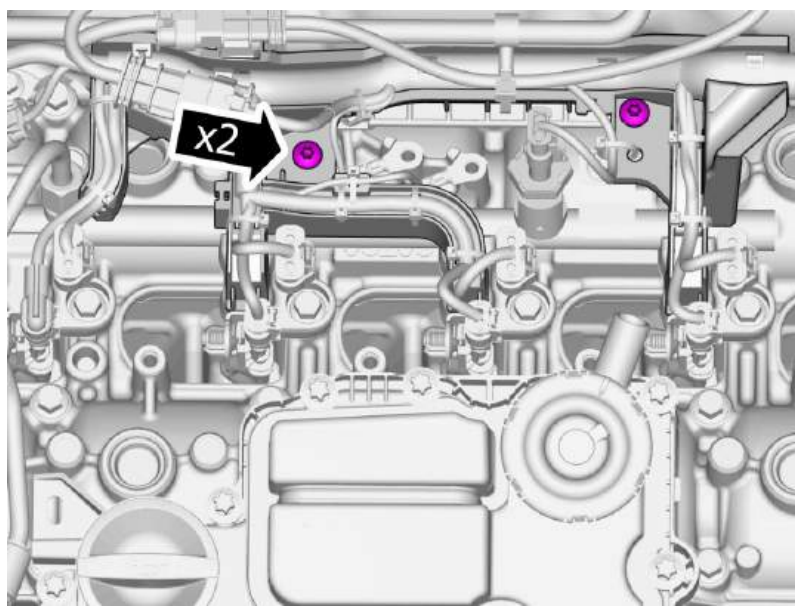

Remove the screws.

**Torque:**

M5 , 5 Nm

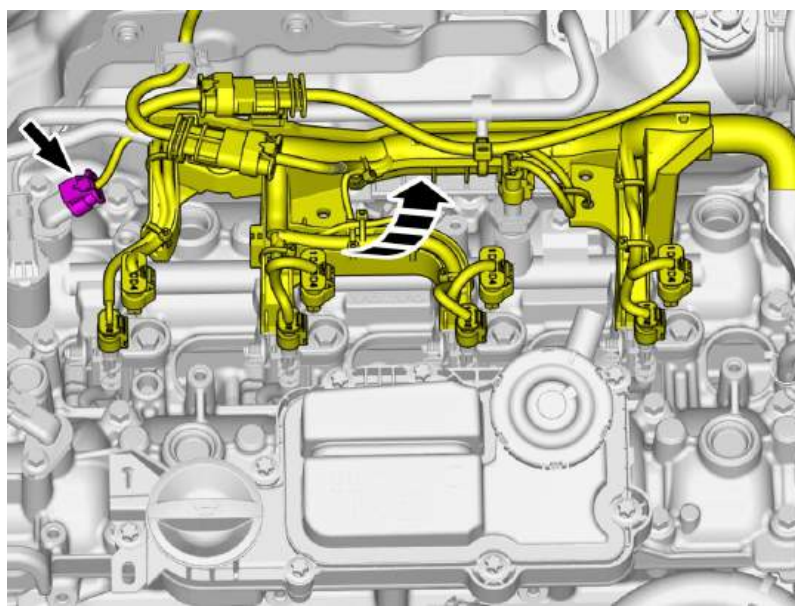

Disconnect the connector.

Fold the cable harness aside.

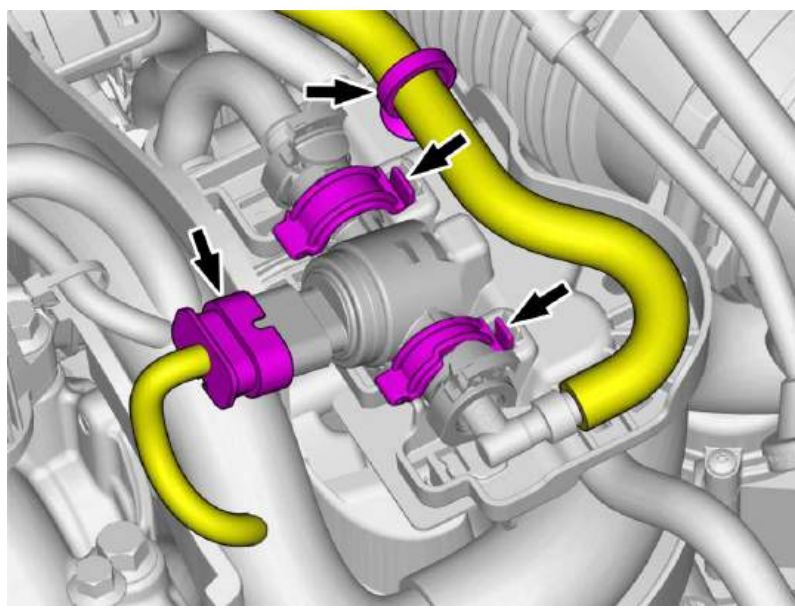

Disconnect the connector.  
Loosen the clips.

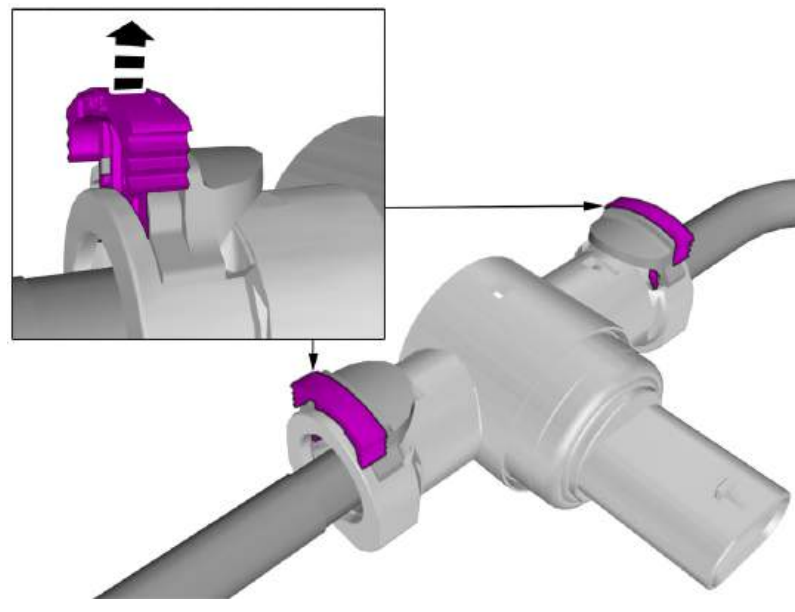

Release the locks.

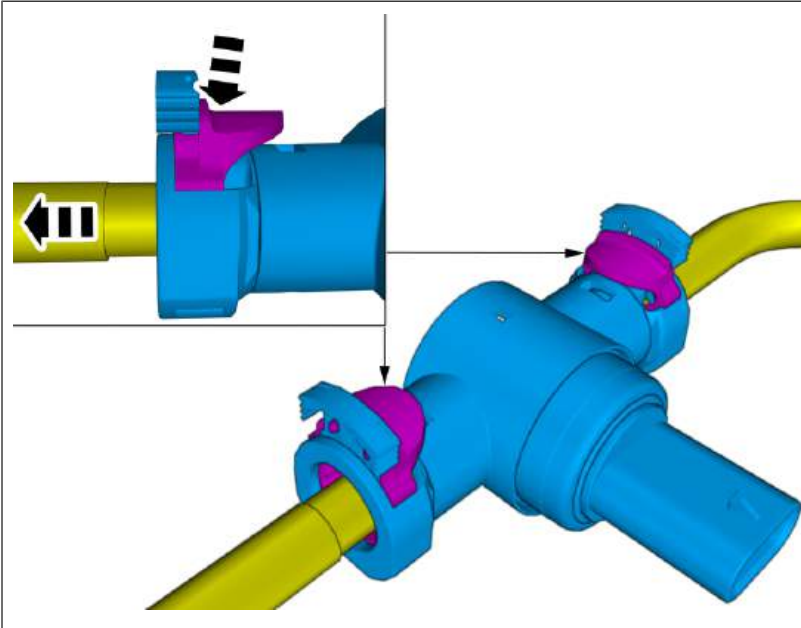

**Warning!** Be prepared to collect escaping fluid.

Depress the locking devices.  
Undo the hoses from the connections.

**Extra information**

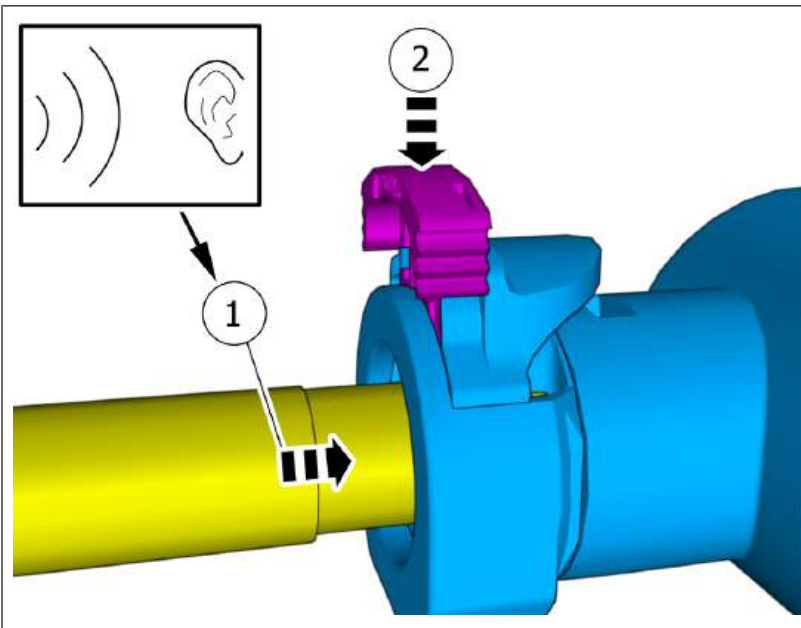

On both sides.

Continue the installation following the steps below.

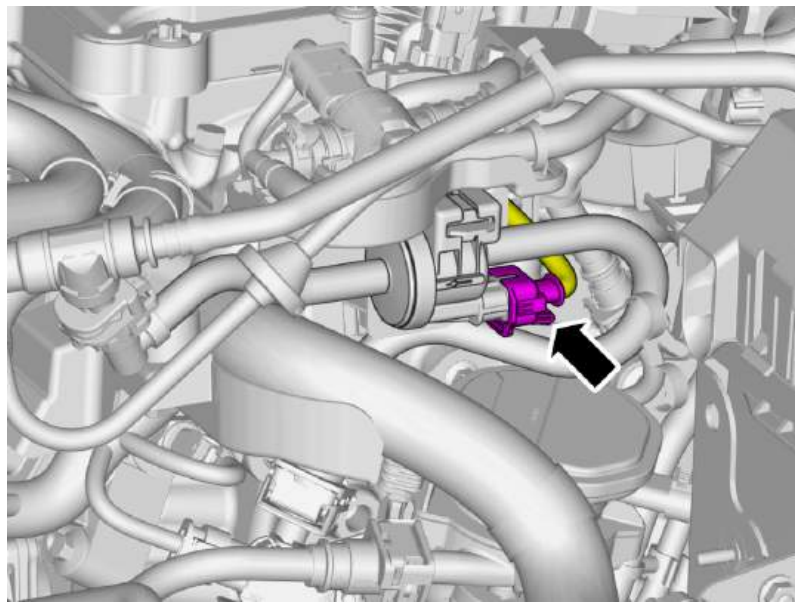

Disconnect the connector.

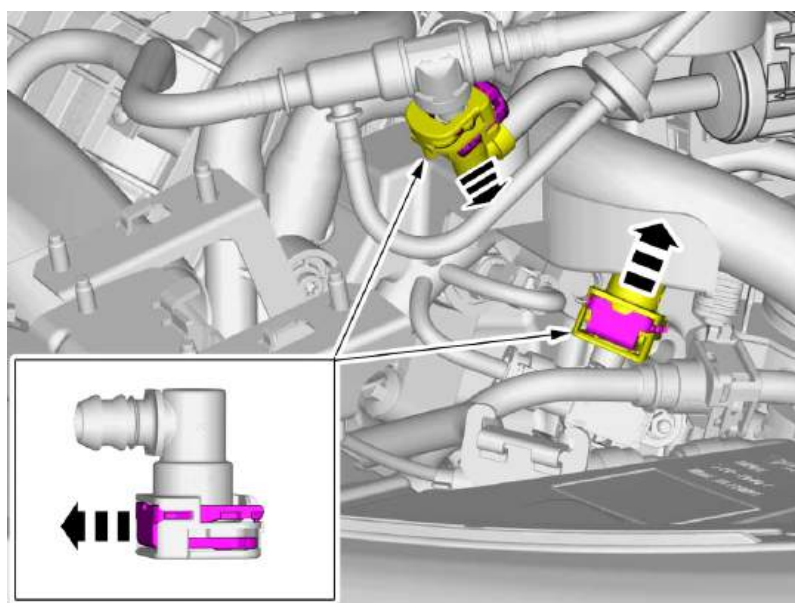

Release the locks.  
Undo the hoses from the connections.

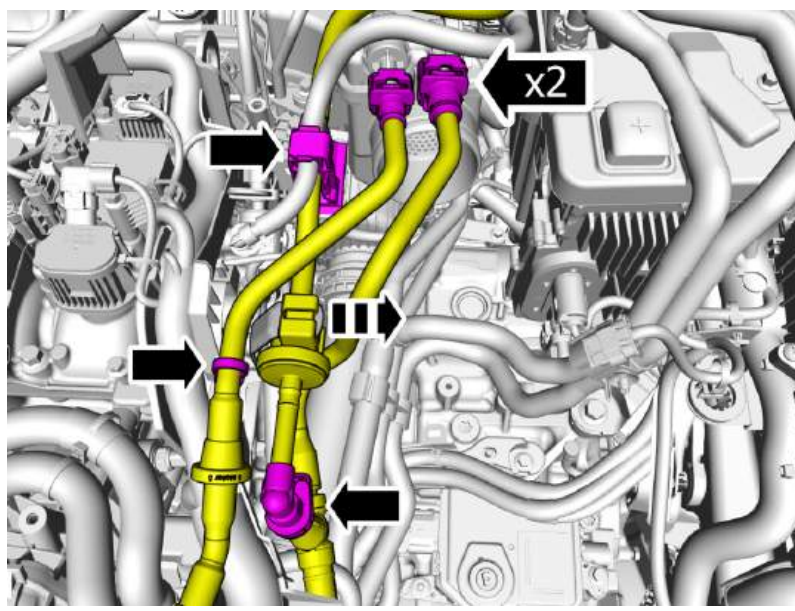

Remove the clips.  
Release the locks.  
Undo the hoses from the connections.  
Fold marked parts aside.

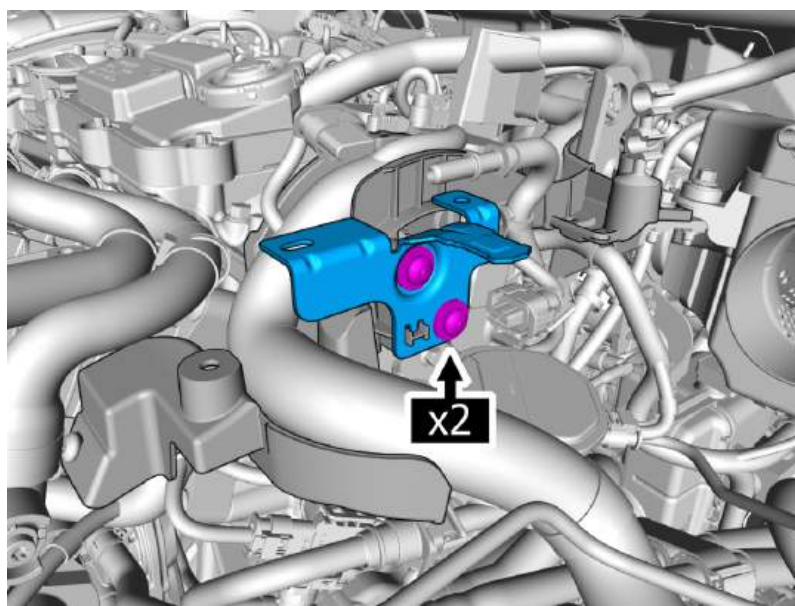

Remove the screws.  
Remove the marked part.

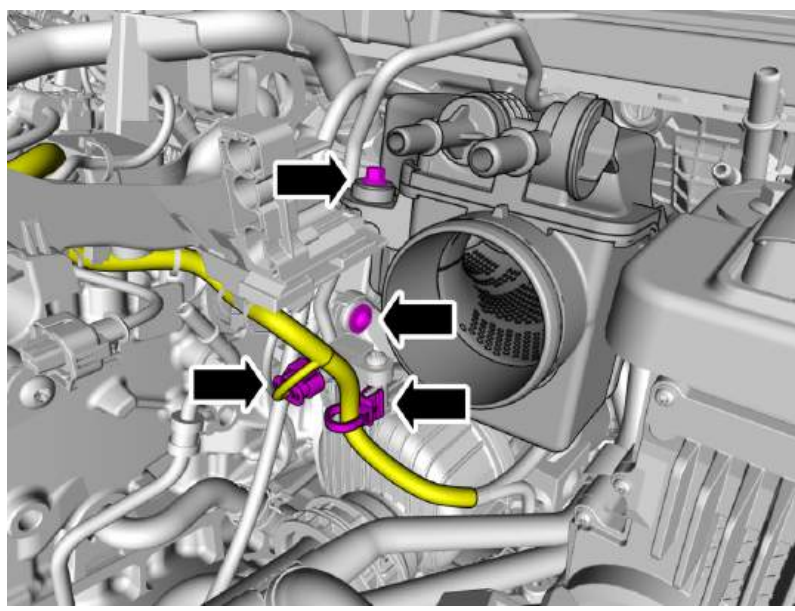

Remove the screws.  
 Disconnect the connector.  
 Loosen the clip.  
 Fold marked parts aside.

**Torque:**

M6 , 10 Nm

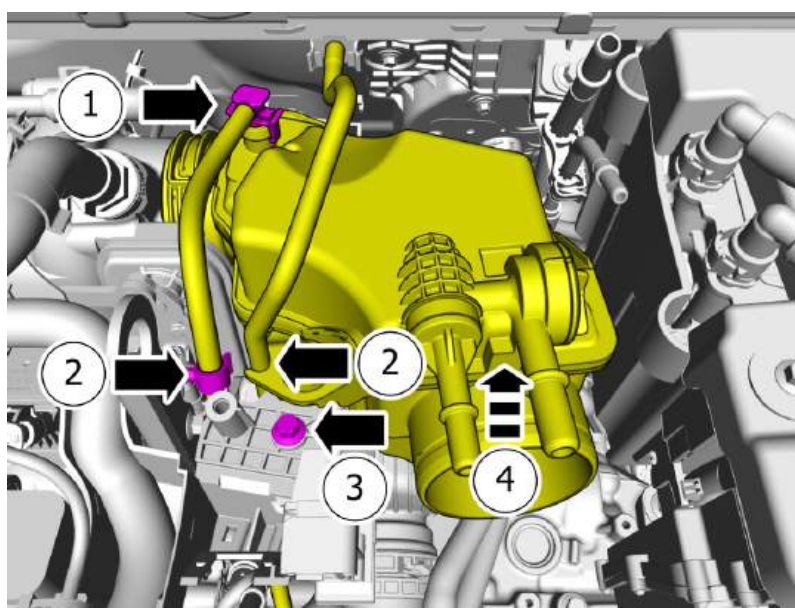

- 1 . Undo the hose from the connection.
- 2 . Loosen the marked details from the clip/ clips.
- 3 . Remove the screw.
- 4 . Turn in direction of arrow until stop.

5 . **Torque:**

M6 , 10 Nm

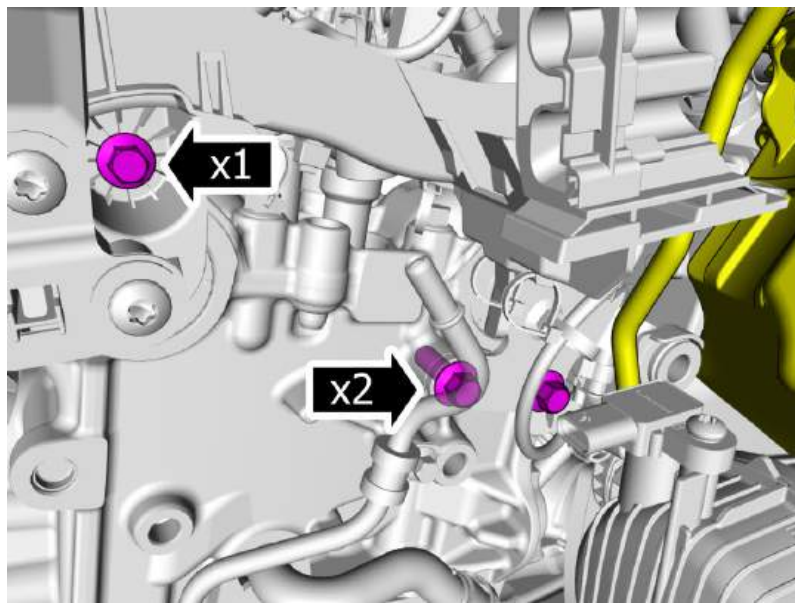

Remove the screws.

- 1 · **Torque:**  
M6 , 10 Nm
- 2 · **Torque:**  
M8 , 24 Nm

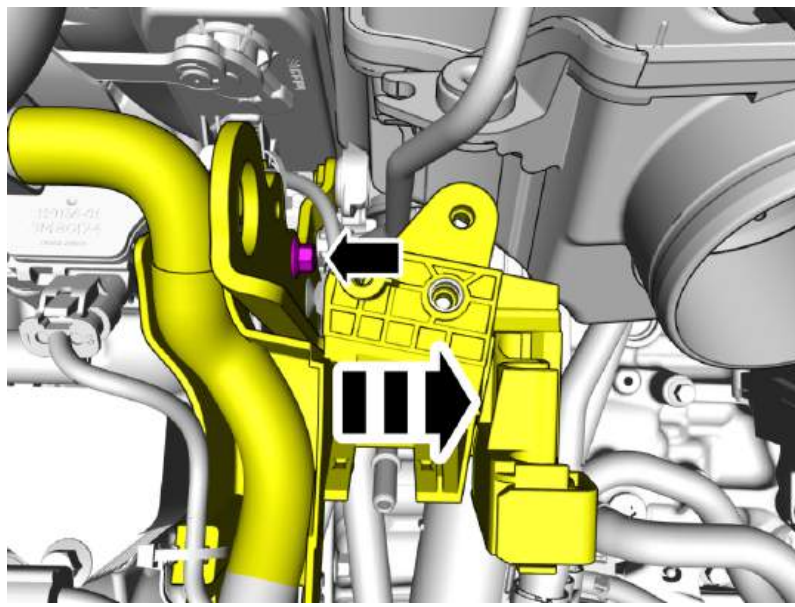

Remove the screw.  
Fold marked parts aside.

**Torque:**  
M6 , 10 Nm

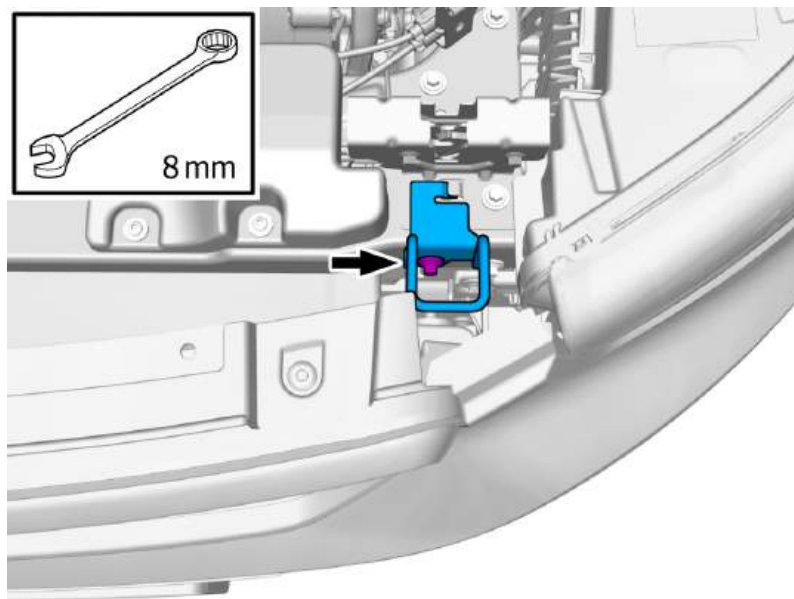

Remove the screw.  
Remove the marked part.

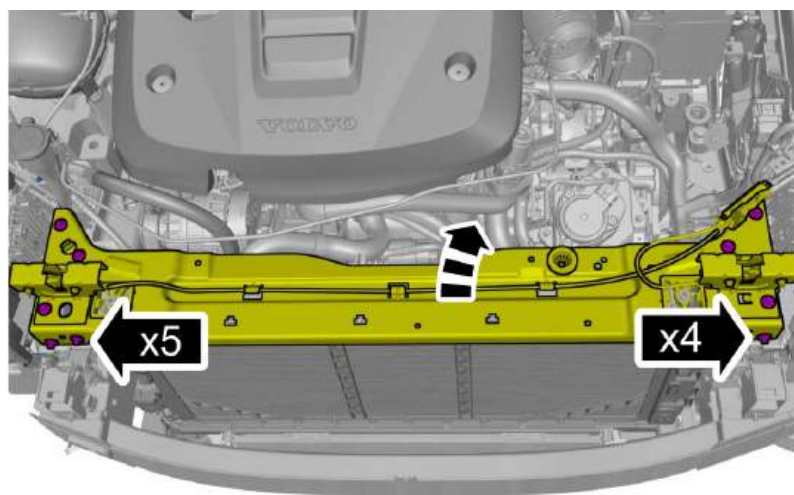

**Note! Note the position of the component before removal.**

Remove the screws.  
Fold marked part aside.

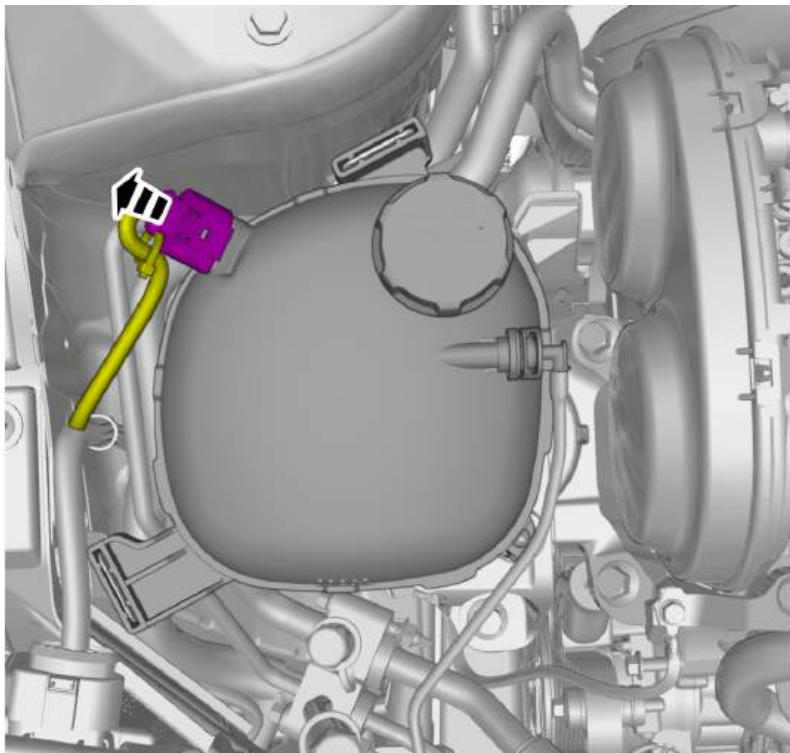

Disconnect the connector.  
Fold marked part aside.

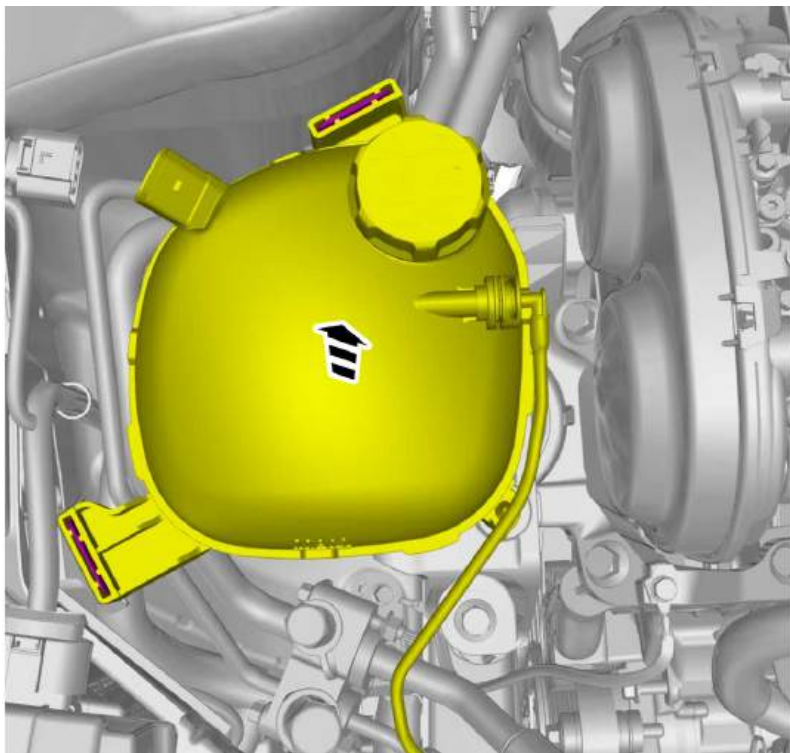

Lift the marked component up  
Fold marked part aside.

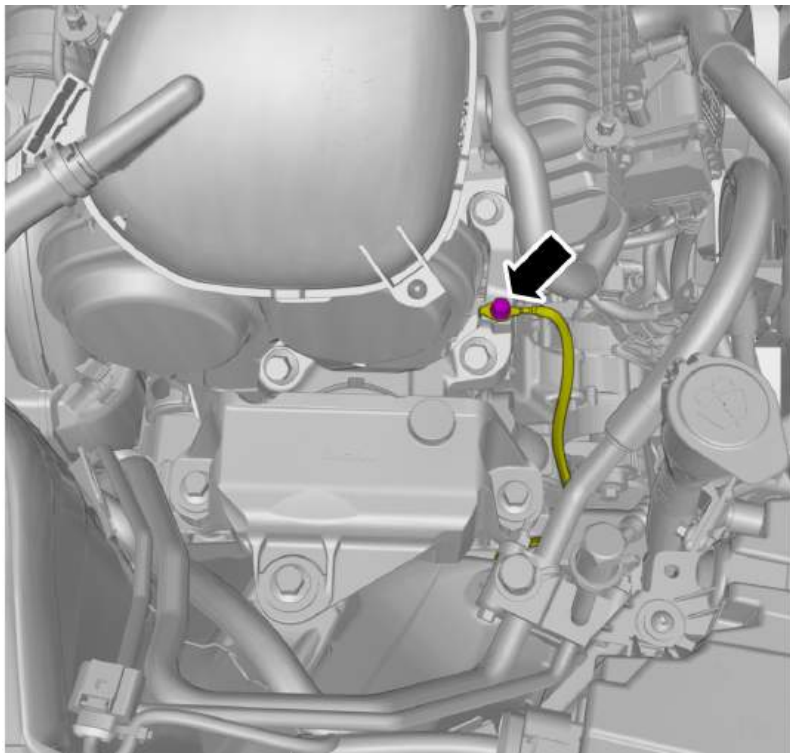

Remove the screw.  
Fold marked part aside.

**Torque:**

M6 , 10 Nm

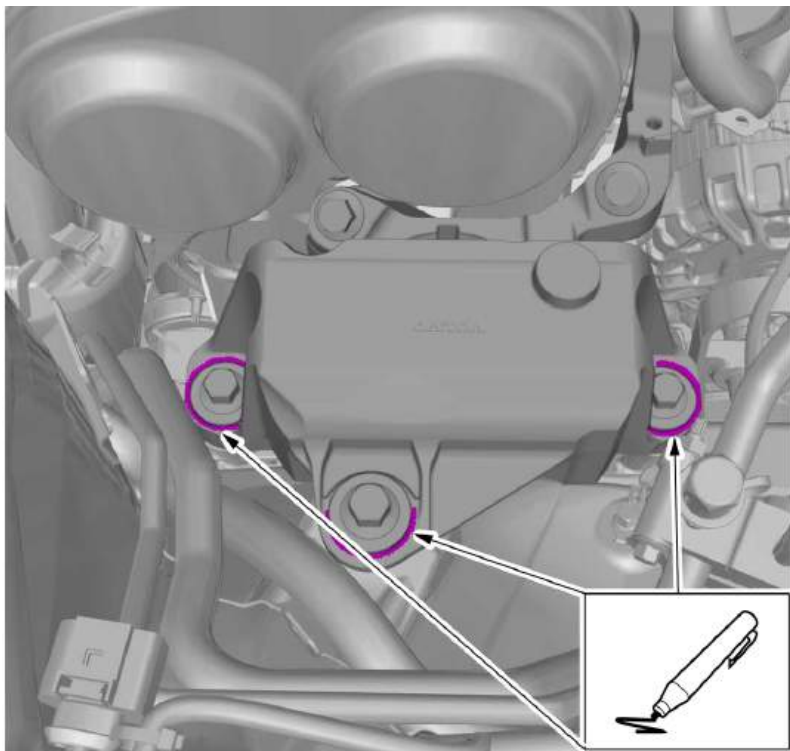

**Note! Note the position of the component before removal.**

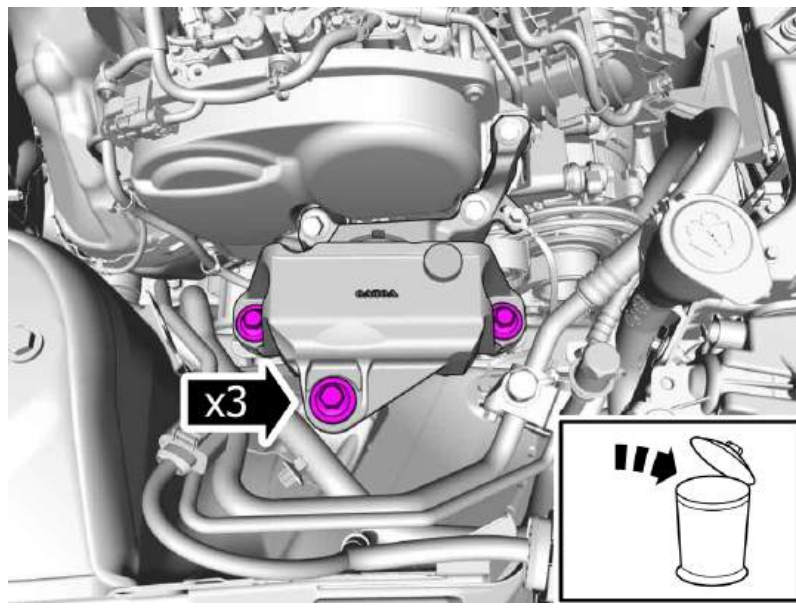

Remove the screws.

**Torque:**

- Stage 1 : Right-hand engine pad to body frame , 90 Nm
- Stage 2 : Right-hand engine pad to body frame , 60°

Remove right side the front wheel , refer to:  
Removal, replacement and installation  
7 - Springs and wheels  
77 - Wheels, tyres  
770 - complete wheels

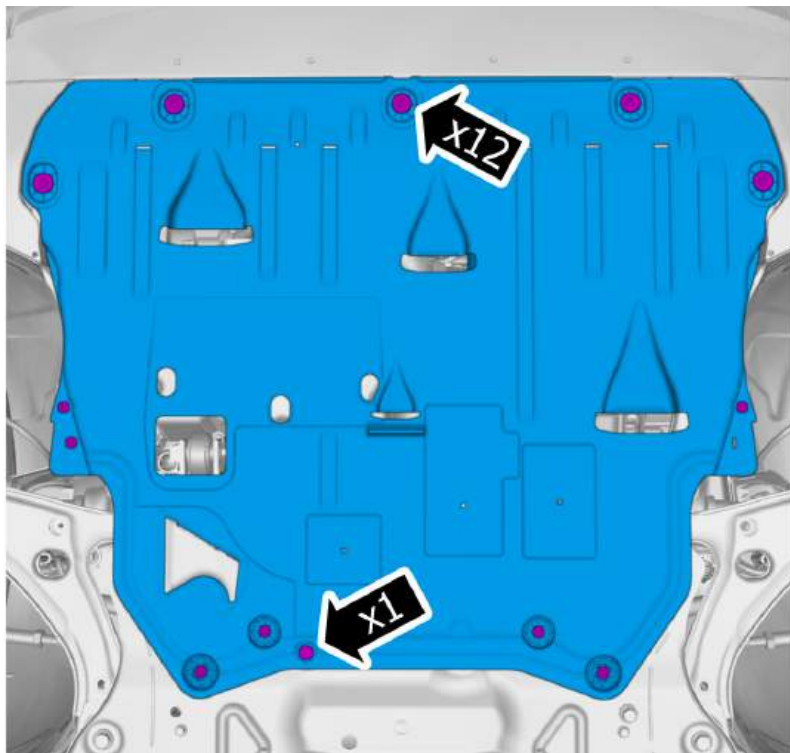

Remove the screws.

Remove the clip.

Remove the marked part.

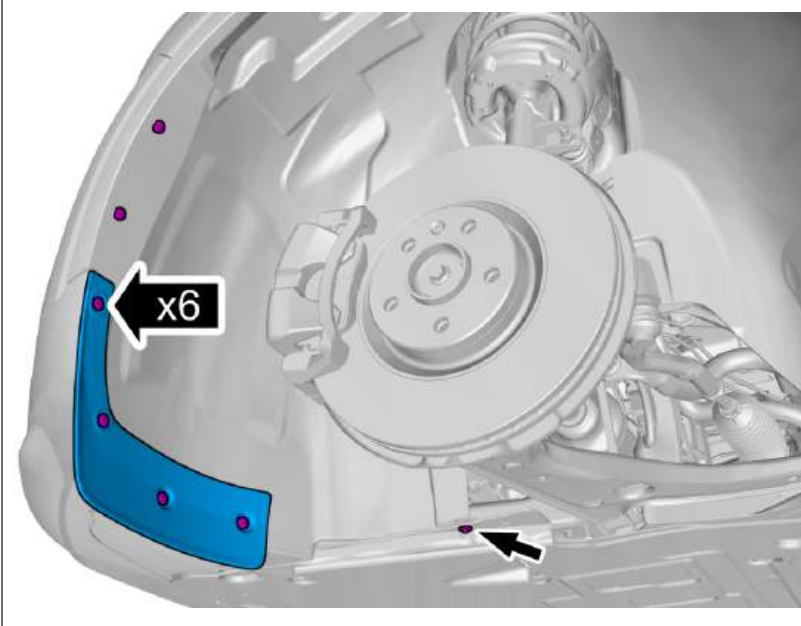

Remove the screws.  
Remove the marked part.

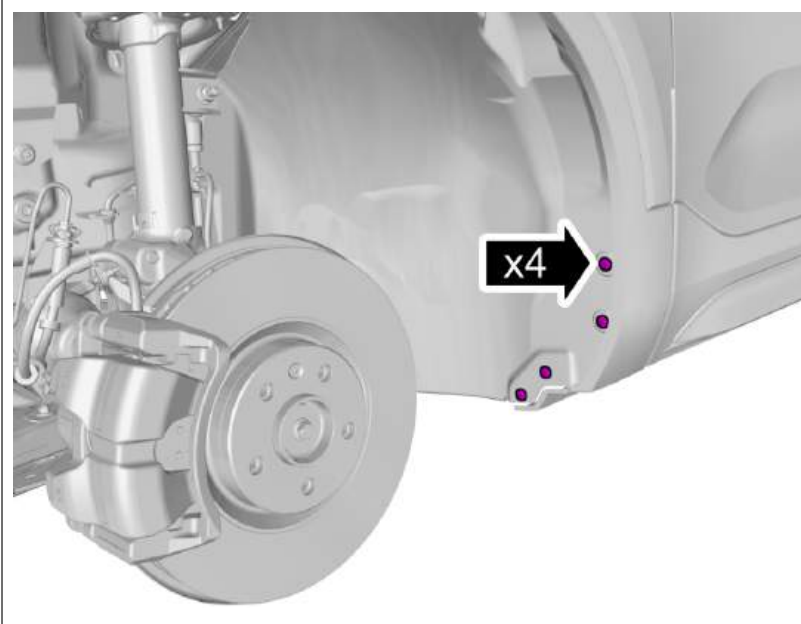

Remove the screws.

Remove the clips.

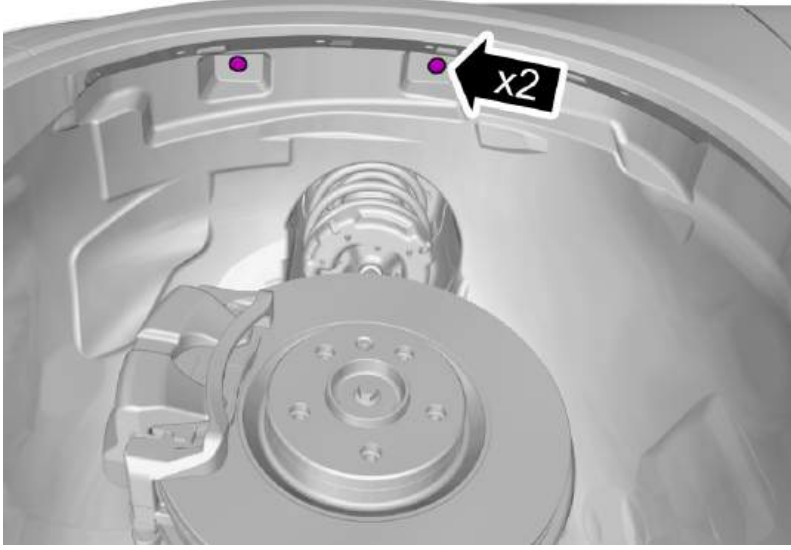

Remove the nuts.

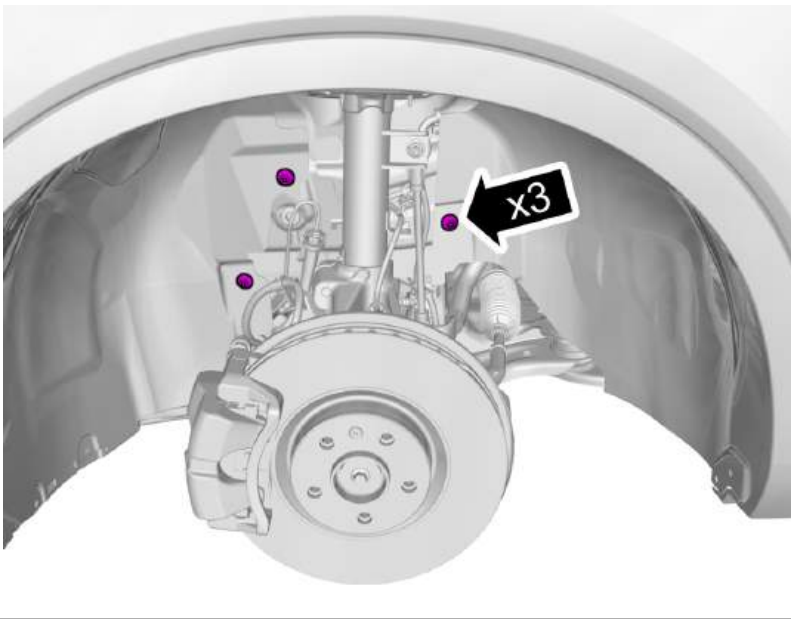

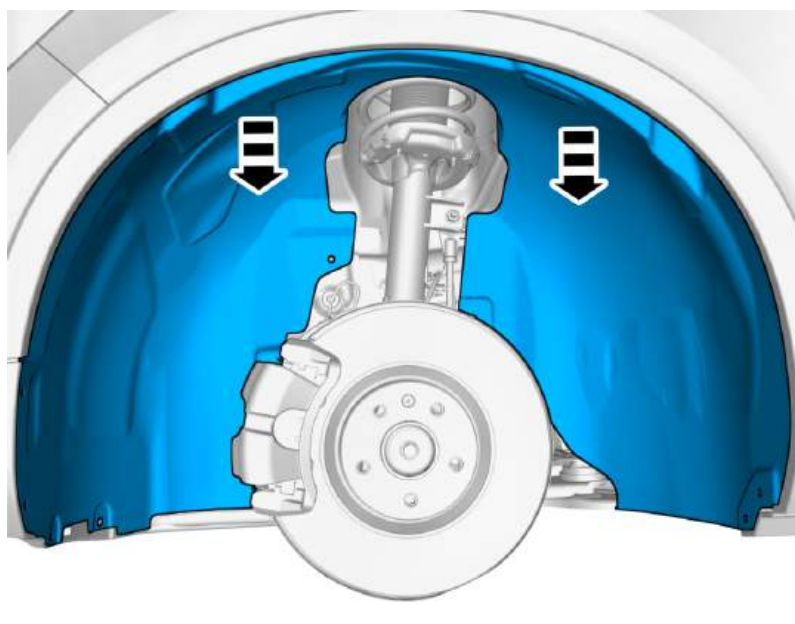

Remove the marked part.

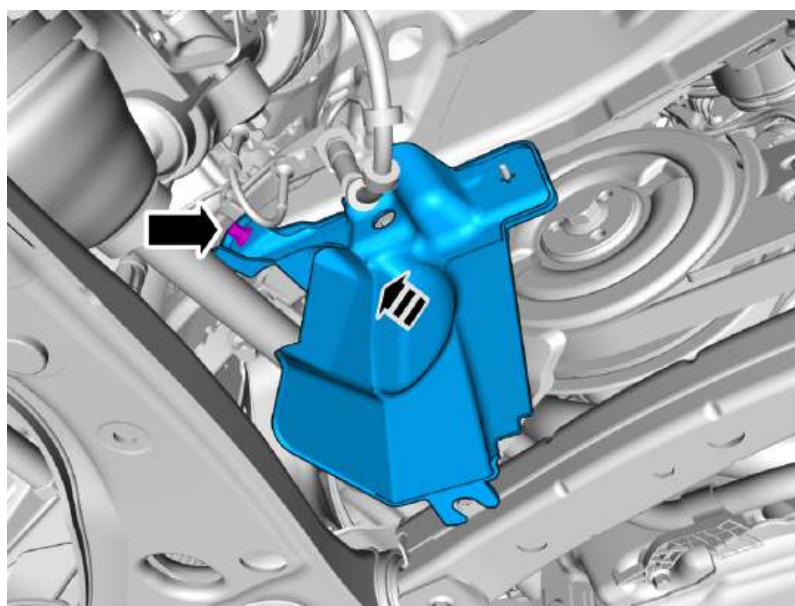

Remove the nut.  
Remove the marked part.

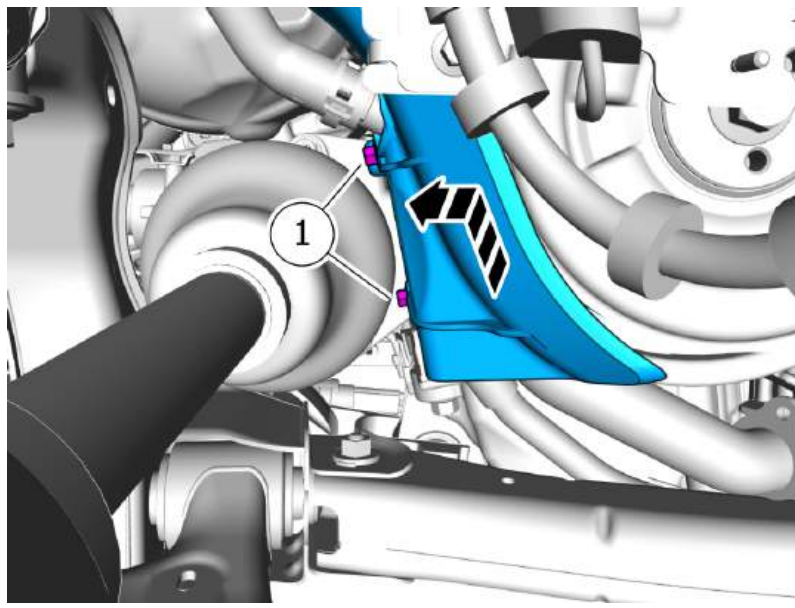

- 1 . Remove the screws.
- 2 . **Torque:**  
M6 , 10 Nm
- 3 . Remove the marked part.

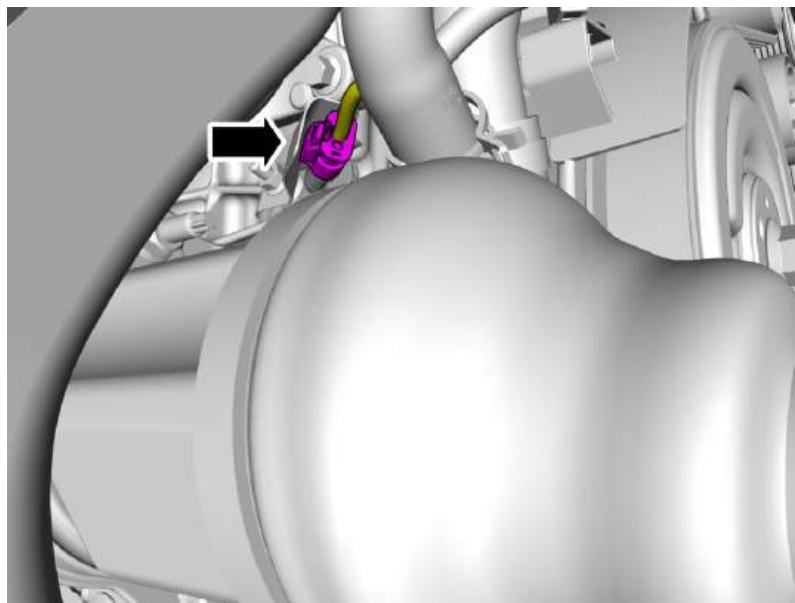

Disconnect the connector.  
Loosen the clips.

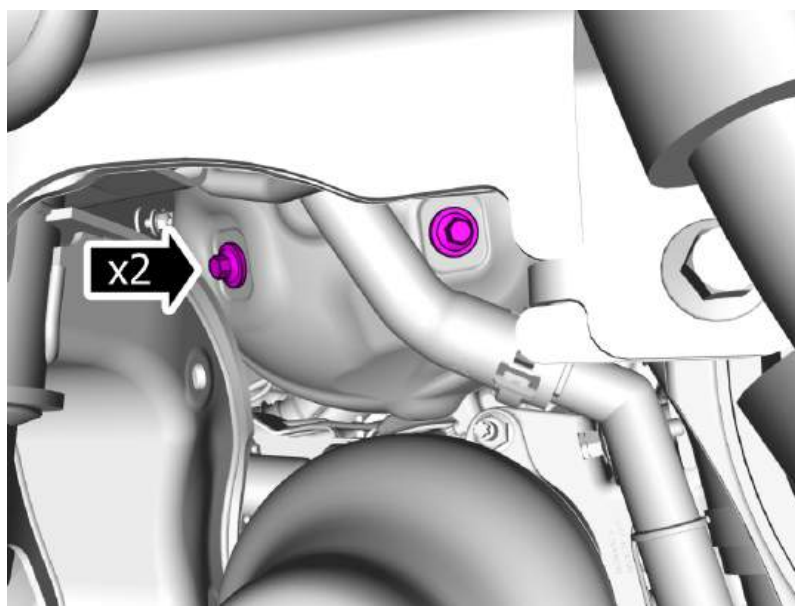

Loosen the screws.  
Do not remove the screws completely.

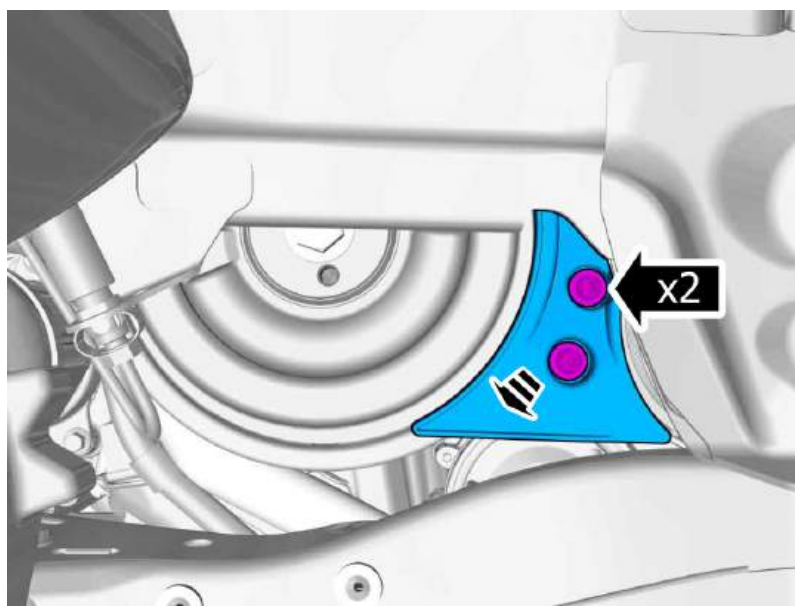

Remove the screws.  
Remove the marked part.



Remove the screws.  
Remove the marked part.

**Torque:**

M6 , 10 Nm

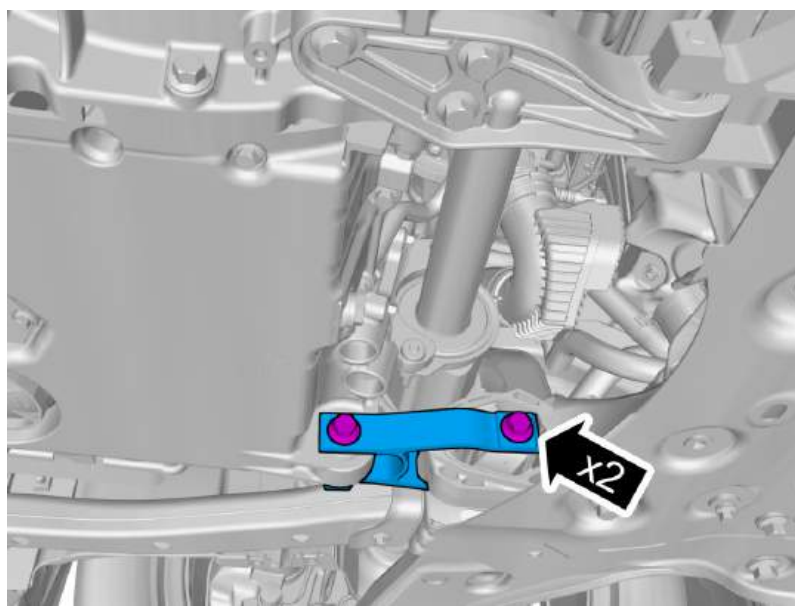

Remove the screws.  
Remove the marked part.

**Torque:**

Lower torque rod rear right, to Engine mount  
bracket , 110 Nm

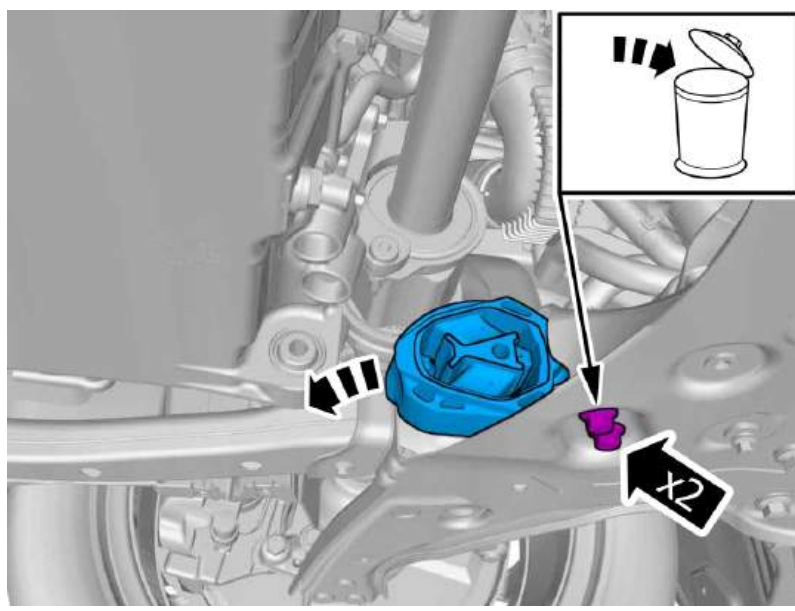

Remove the screws.  
Remove the marked part.

**Torque:**

- Stage 1 : Lower torque rod rear right, to subframe , 90 Nm
- Stage 2 : Lower torque rod rear right, to subframe , 120°

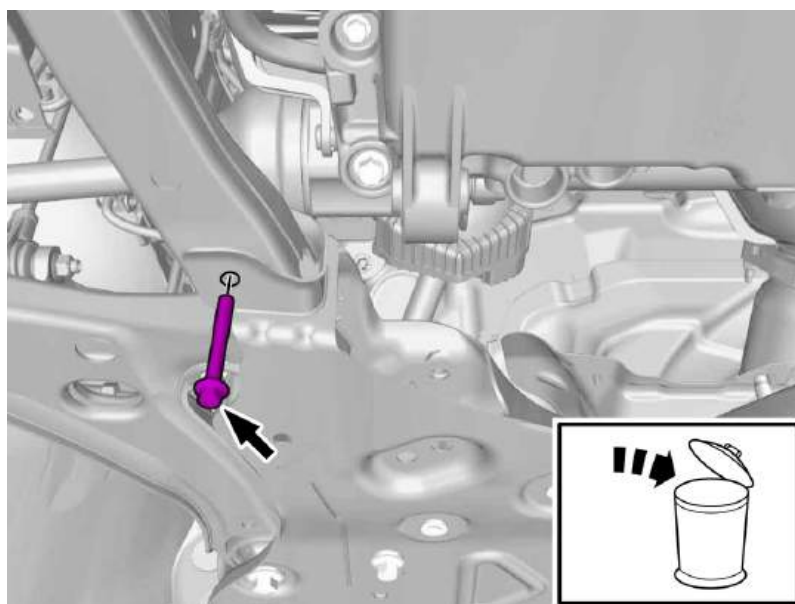

Remove the screw.

**Torque:**

- Stage 1 : Collision member to subframe , 30 Nm
- Stage 2 : Collision member to subframe , 90°

Special Tool: T9997680, Support

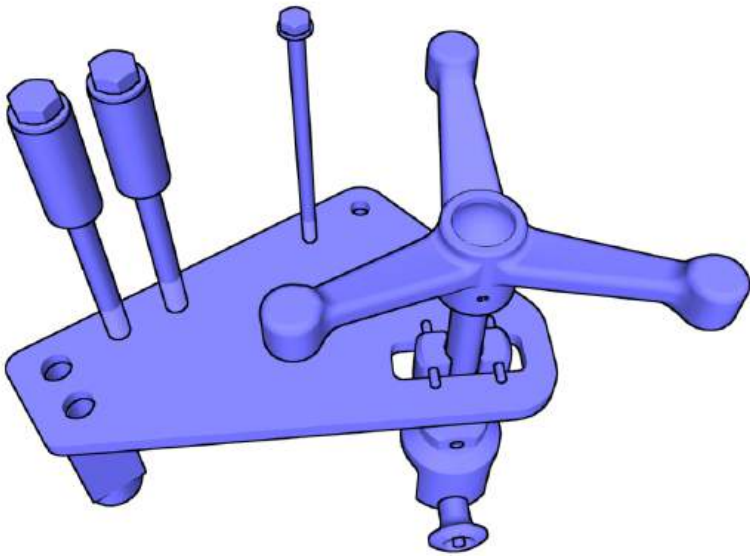

Install the Special tool.

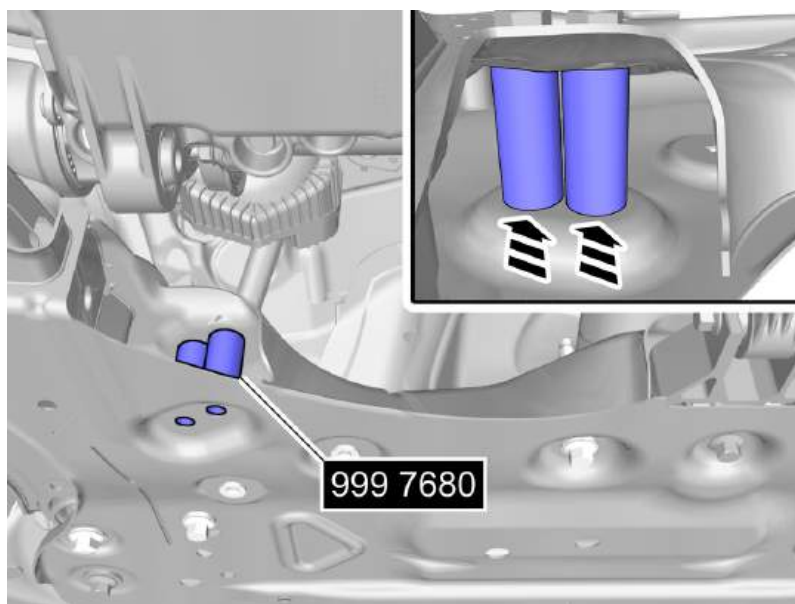

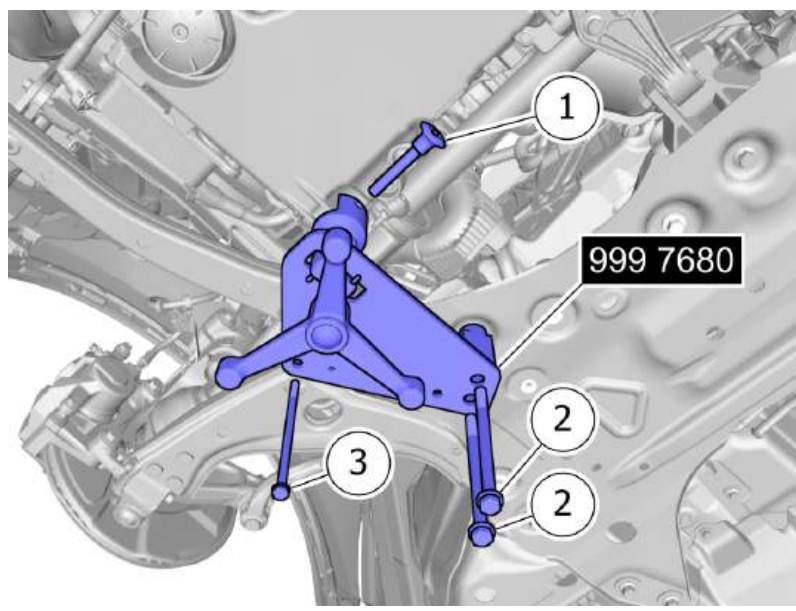

Install the Special tool.

1 . Install the marked component.

2 . **Torque:**  
M12 , 80 Nm

3 . **Torque:**  
M8 , 24 Nm

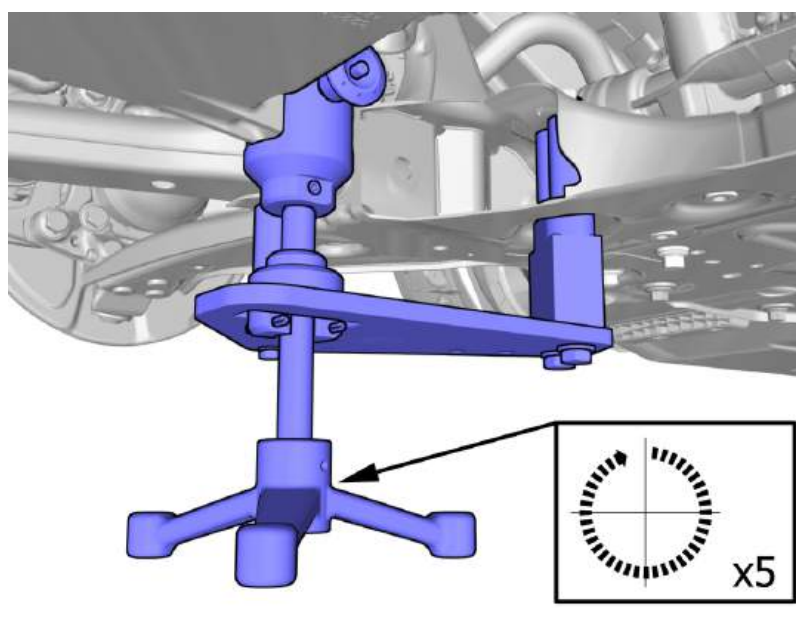

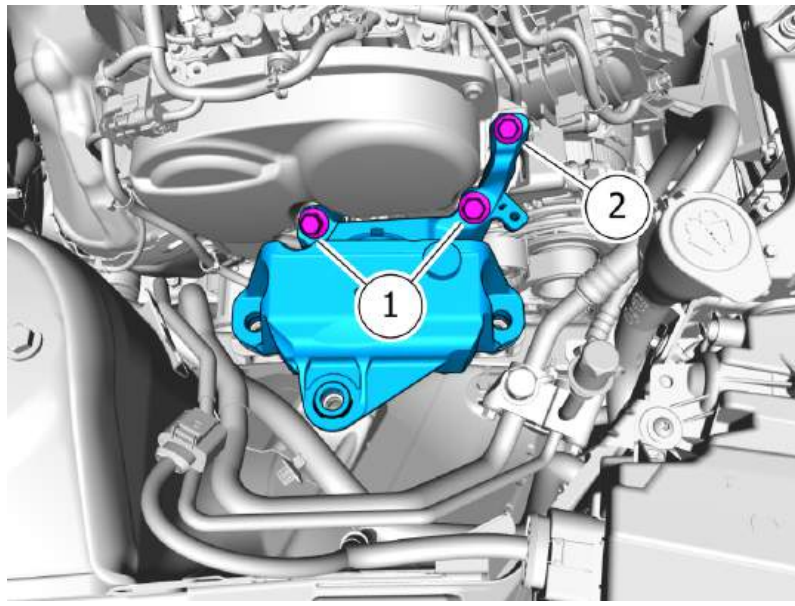

Remove the screws.

1. **Torque:**

- Stage 1 : Engine mount bracket, to Cylinder head, M12 , 90 Nm
- Stage 2 : Engine mount bracket, to Cylinder head, M12 , 90°

2. **Torque:**

Engine mount bracket, to Cylinder head, M10 , 60 Nm

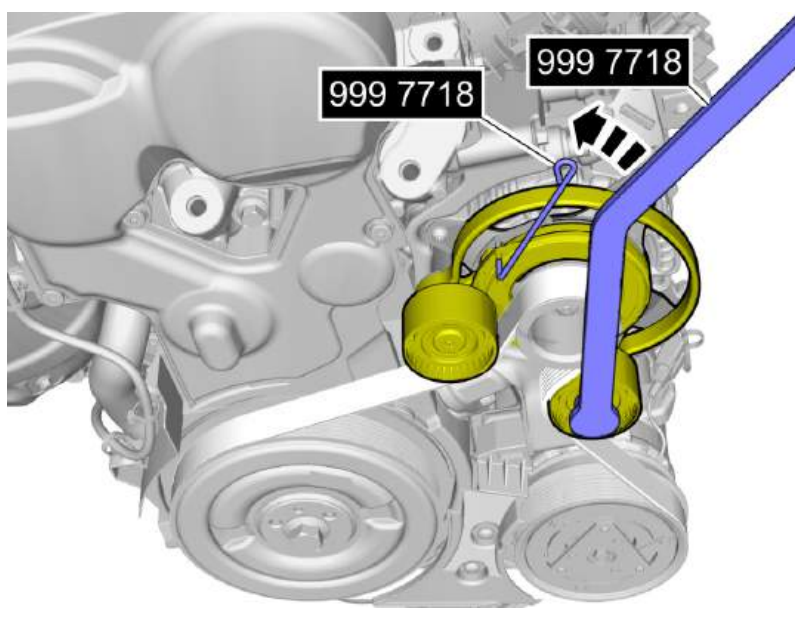

Install the Special tool.

Special Tool: T9997718, Counterhold

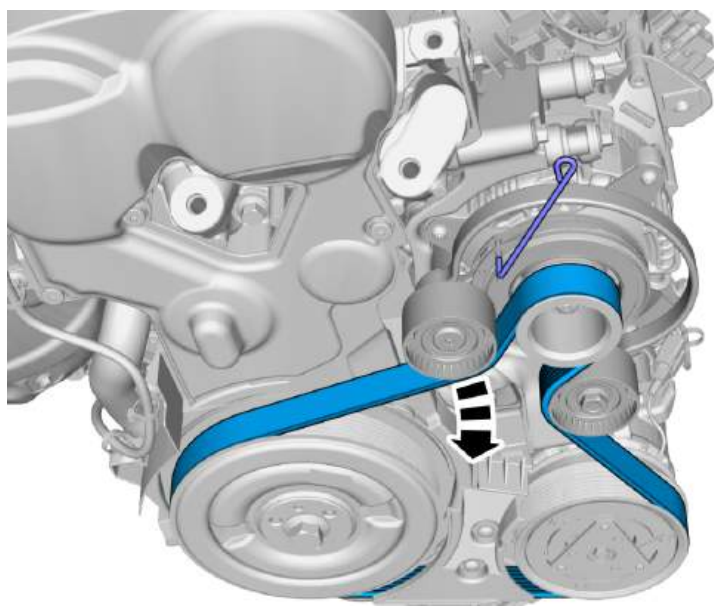

Remove the marked part.

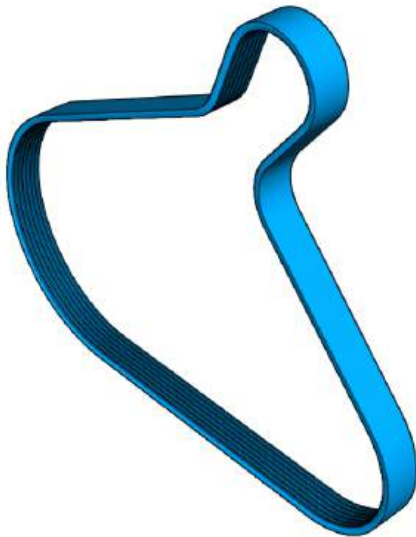

**Note!** The component can be reused unless it has been subjected to abnormal mechanical stress, damage or oil contamination.

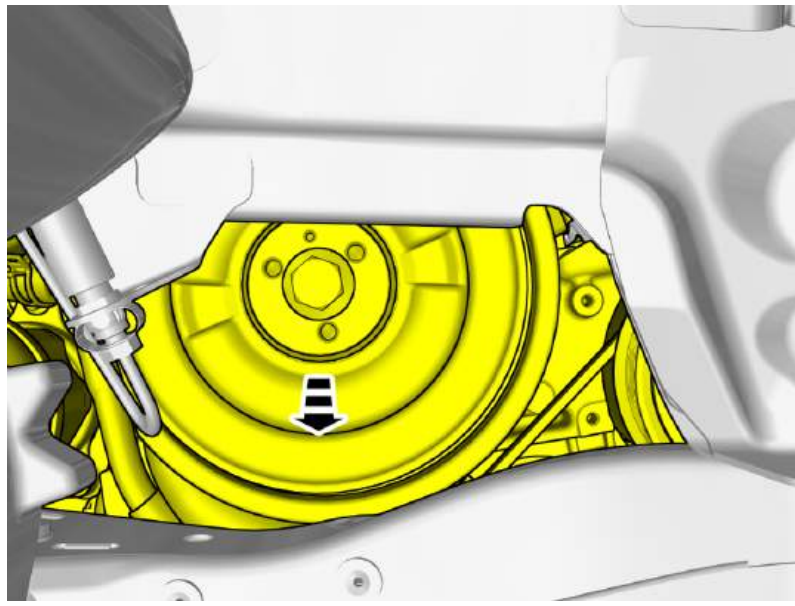

Lower the engine.

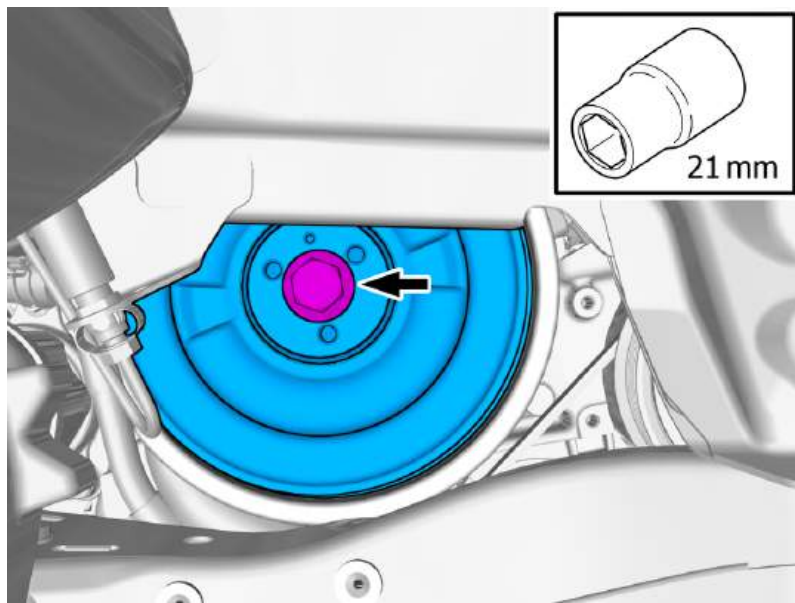

**Note! Note the position of the component before removal.**

Remove the screw.  
Remove the marked part.

Extra information

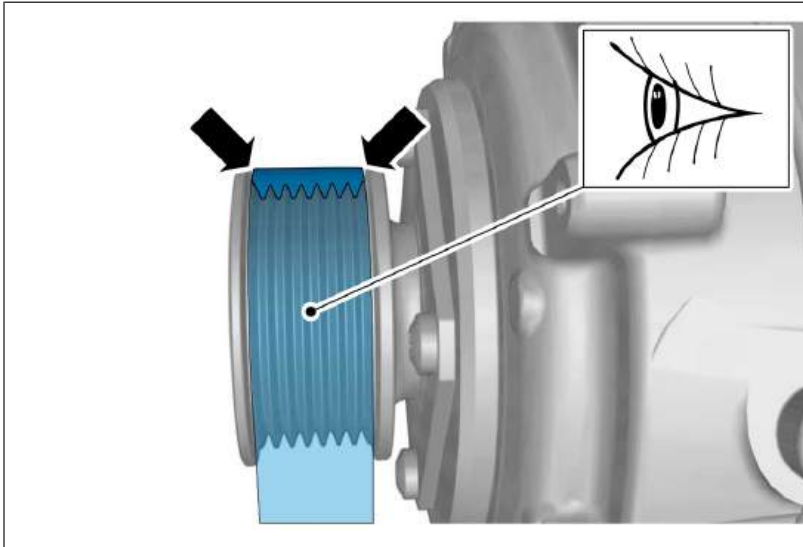

Caution! Make sure that the component is positioned correctly.

Continue the installation following the steps below.

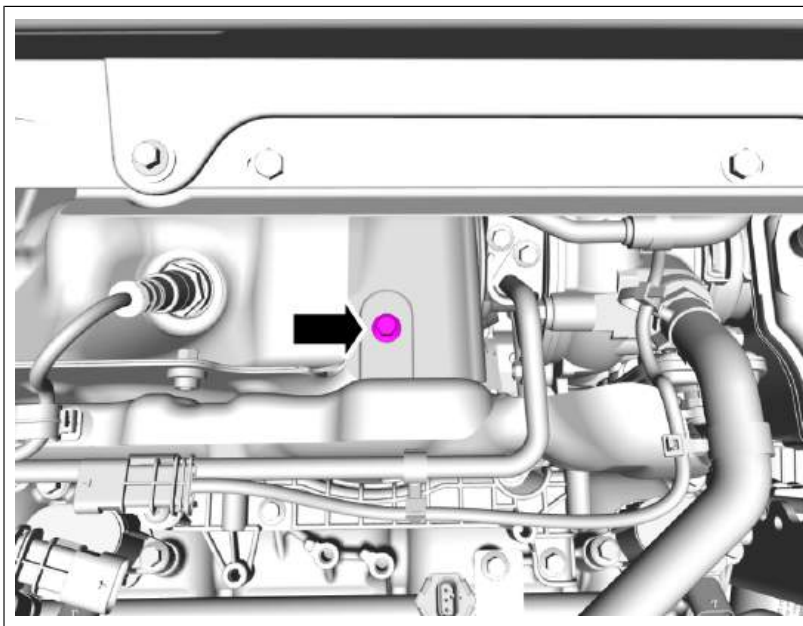

Remove the screw.

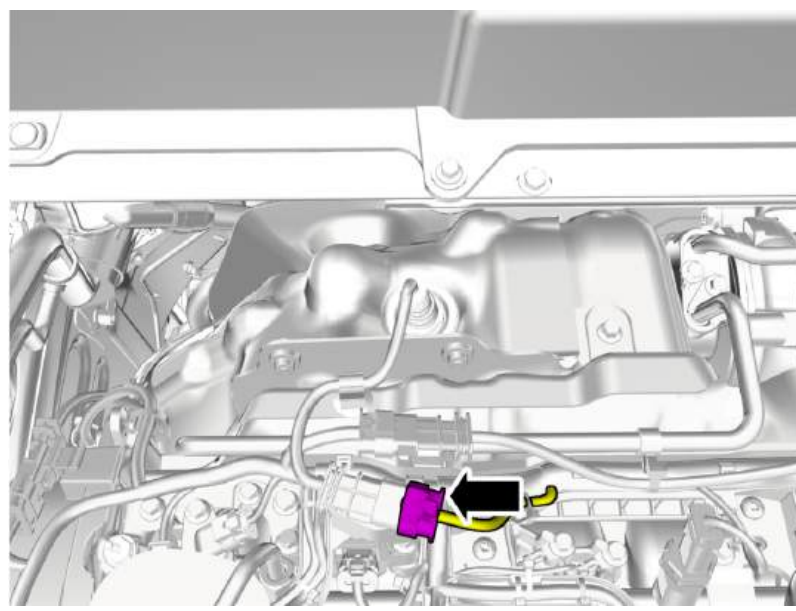

Disconnect the connector.

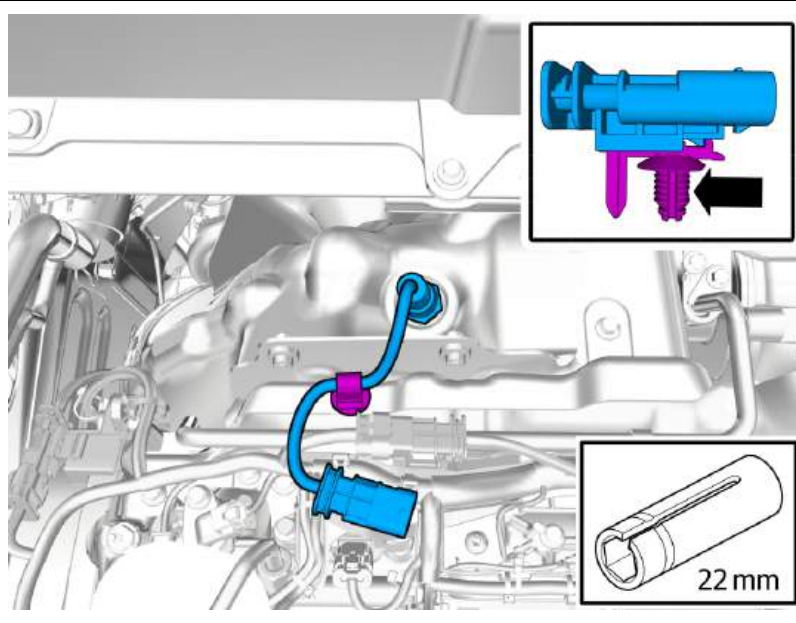

Loosen the clips.  
Remove the marked part.

**Torque:**

Lambda probe, tightening , 45 Nm

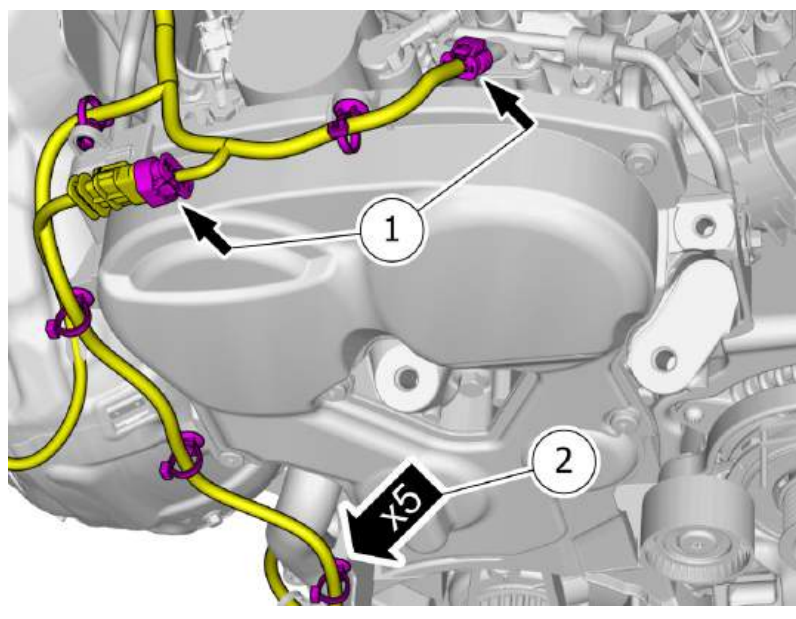

Disconnect the connectors.  
Remove the cable harness clips.  
Fold marked part aside.

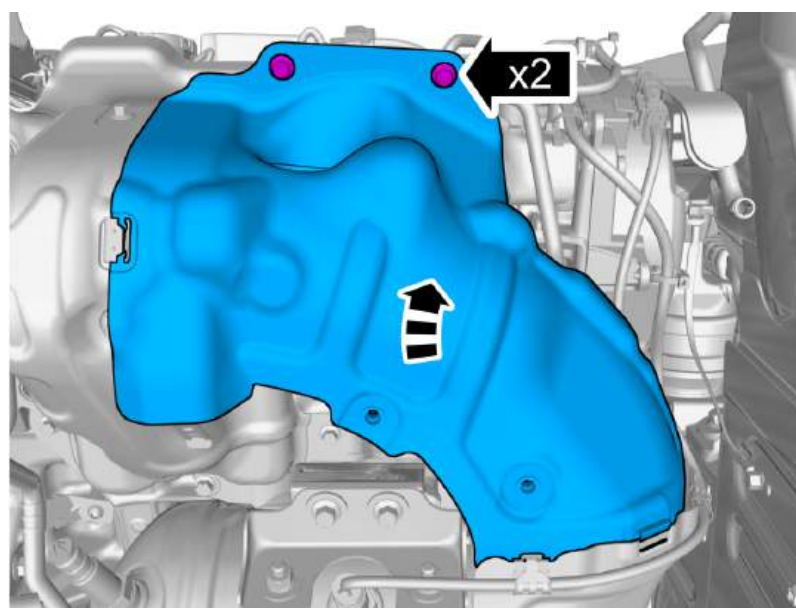

Remove the screws.  
Remove the marked part.

Vehicles early version

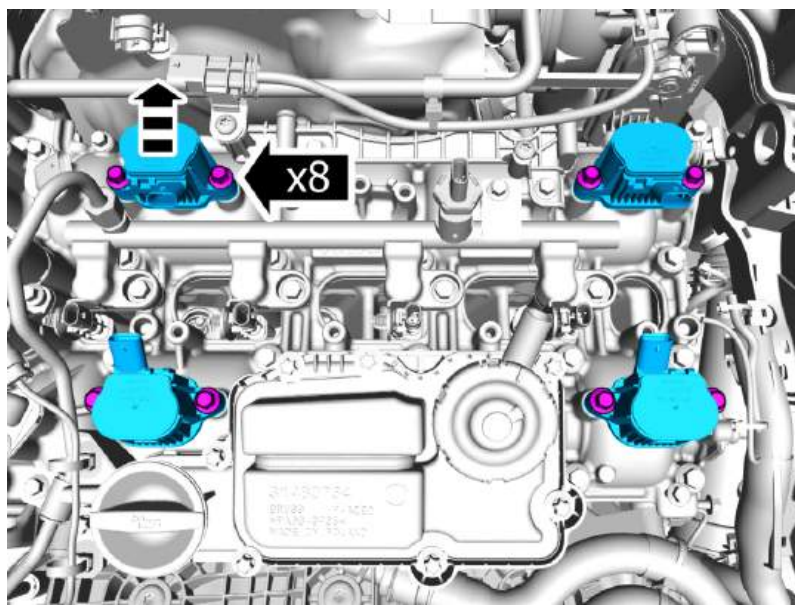

**Caution!** The component must be removed by hand. Tools may not be used.

**Note!** Use new seals.

Remove the screws.  
Remove the marked parts.

**Torque:**

M6 , 10 Nm

All vehicles

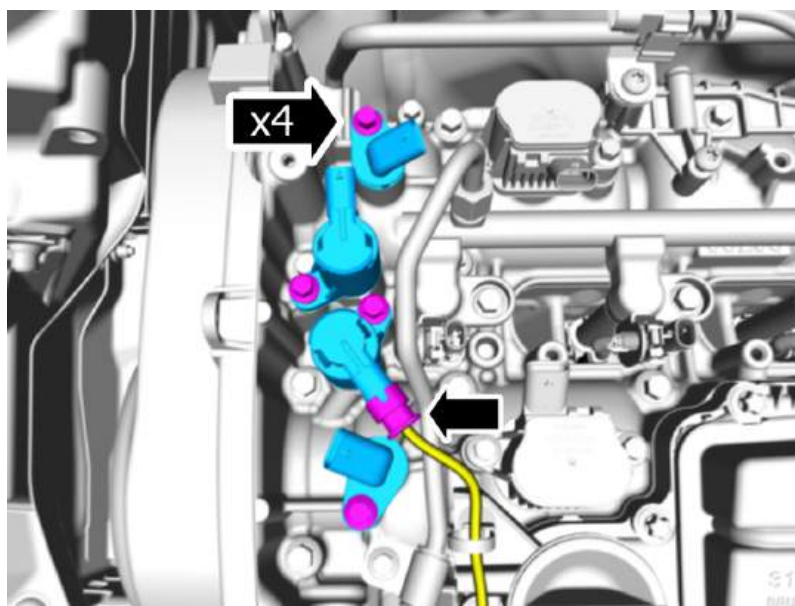

Disconnect the connector.  
Remove the screws.  
Remove the marked parts.

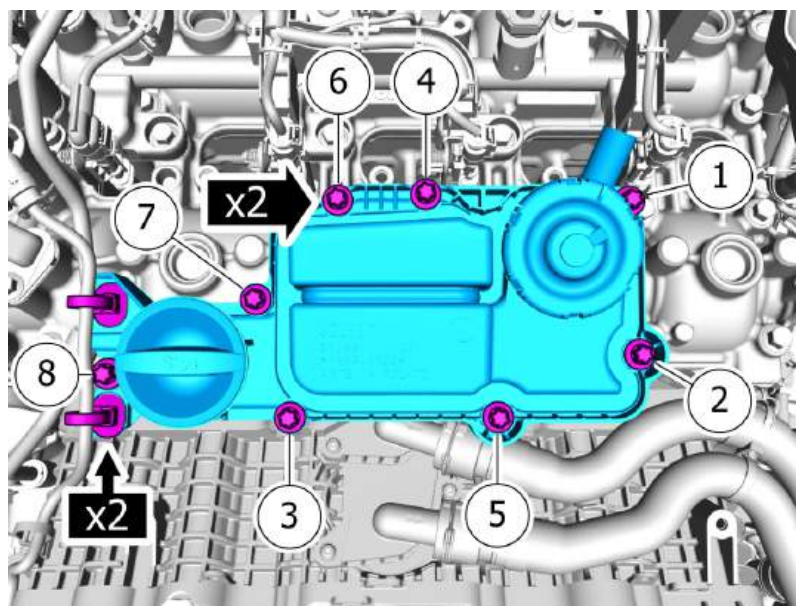

**Note! Make sure to follow the correct sequence during installation.**

**Note! Use a new seal.**

Remove the clips.  
Remove the screws.  
Remove the marked part.

**Torque:**

M6 , 10 Nm

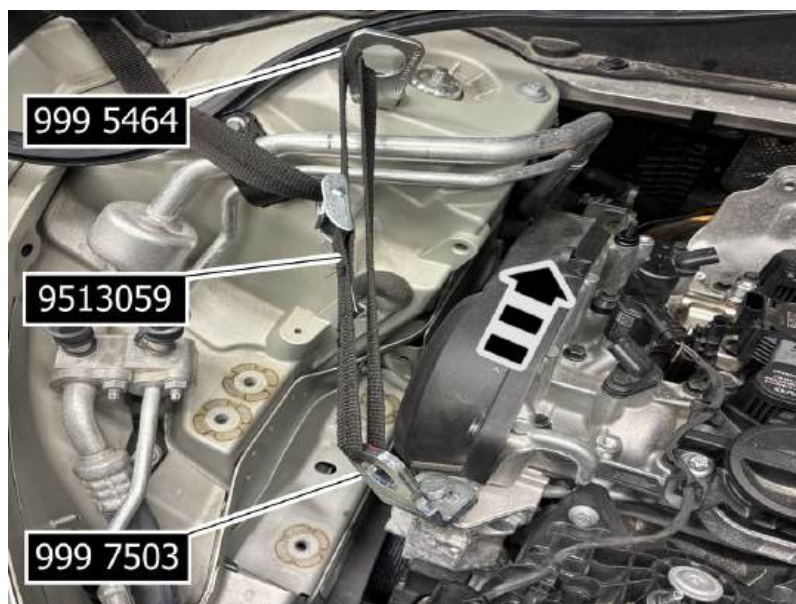

Install the Special tool.

Pull the component in direction of the arrow.

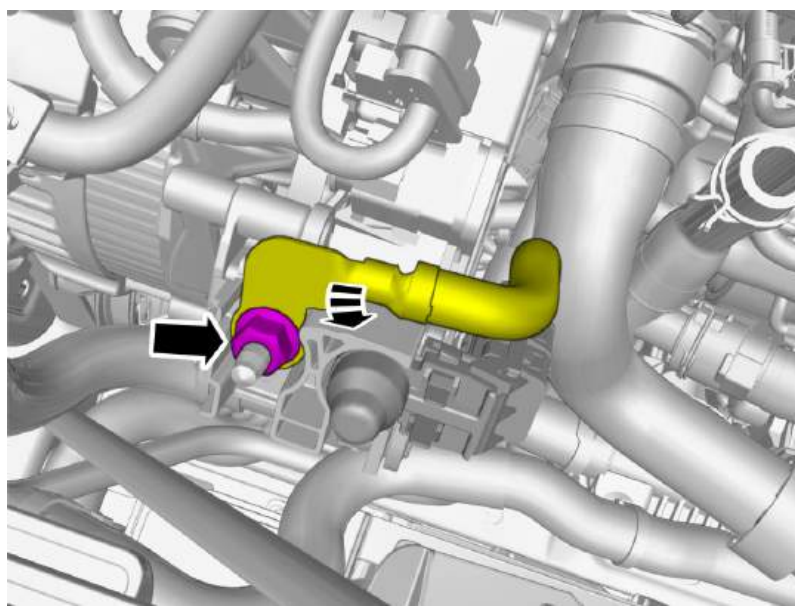

Remove the nut.

**Torque:**

M8 , 24 Nm

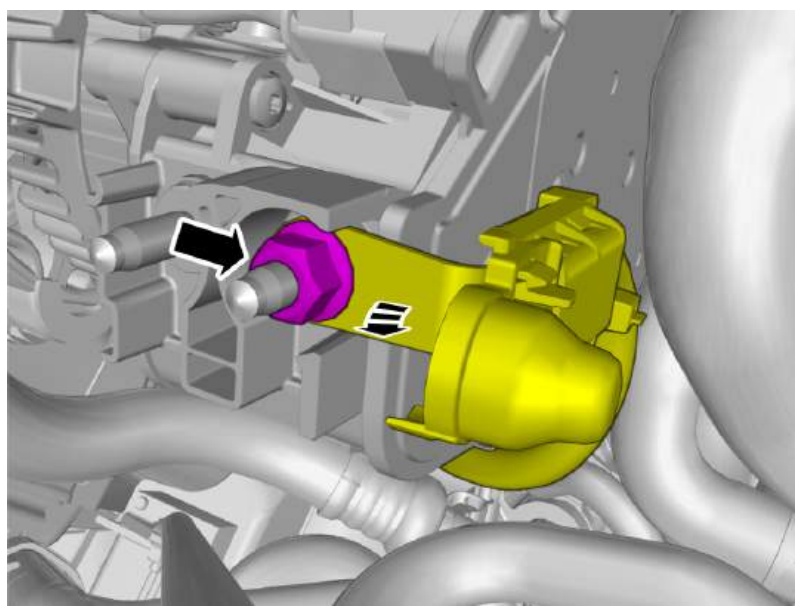

Remove the nut.

**Torque:**

M8 , 24 Nm

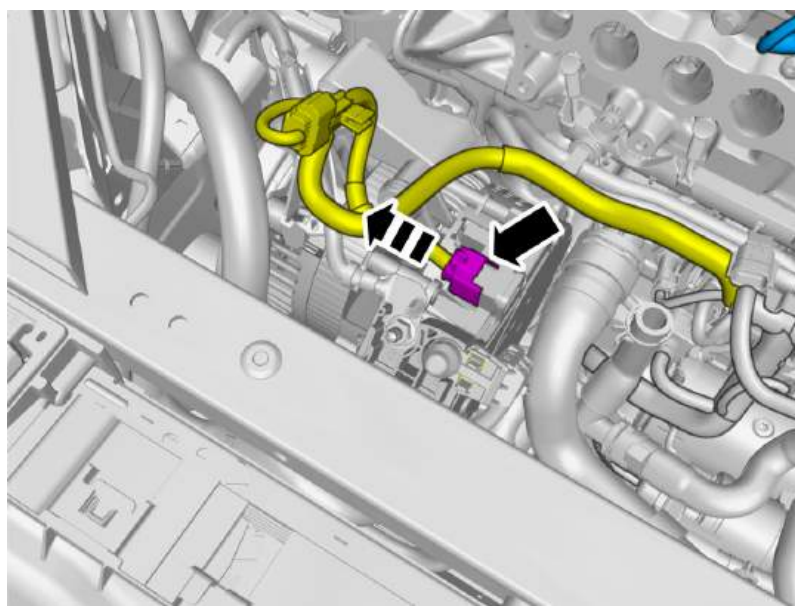

Disconnect the connector.

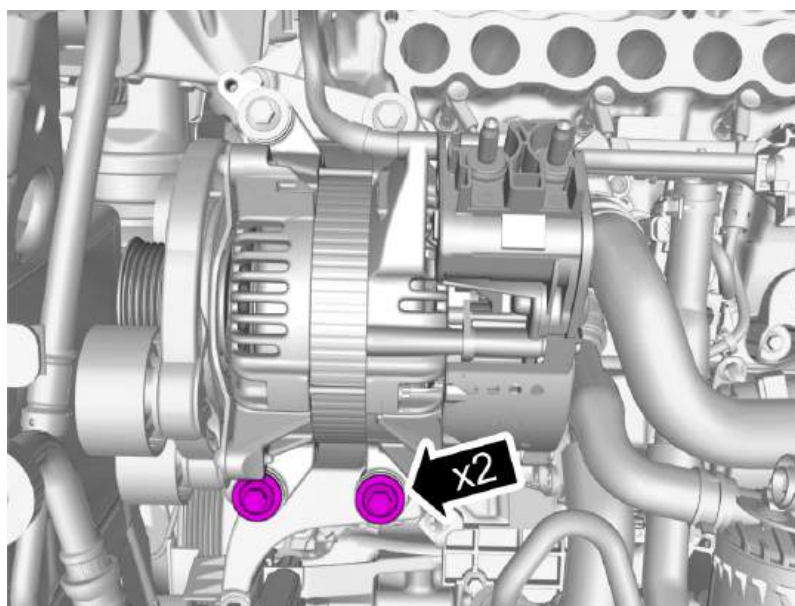

Remove the screws.

**Torque:**

M8 , 24 Nm

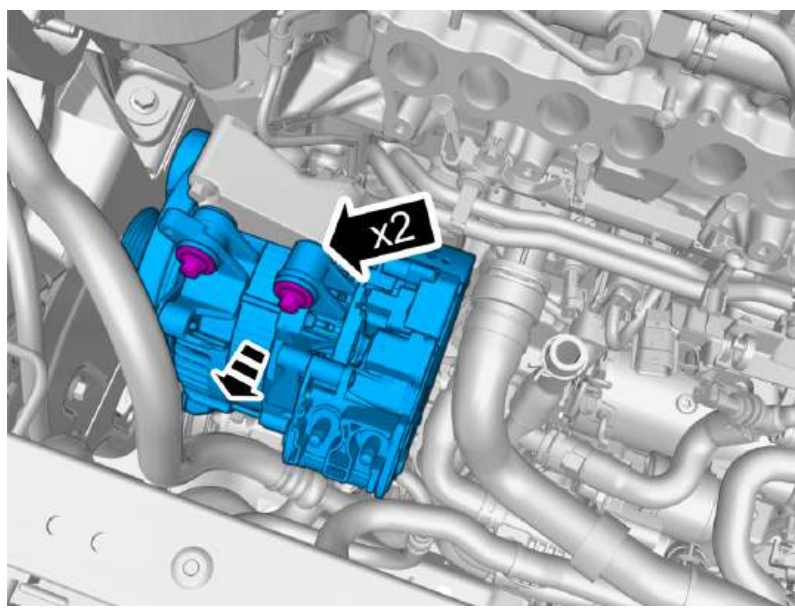

Remove the screws.  
Remove the marked part.

**Hint: It may be necessary to twist or turn the component.**

**Torque:**

M8 , 24 Nm

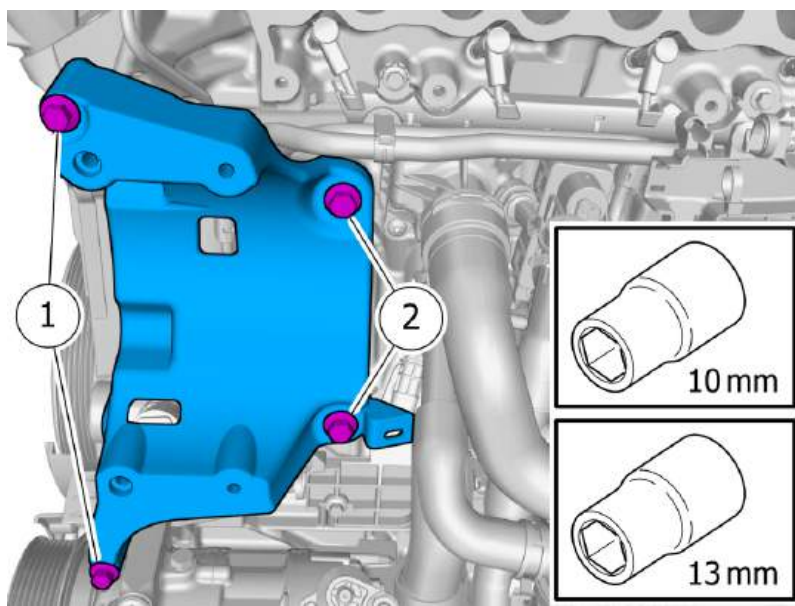

Remove the screws.  
Remove the marked part.

1 · **Torque:**

M8 , 24 Nm

2 · **Torque:**

M10 , 50 Nm

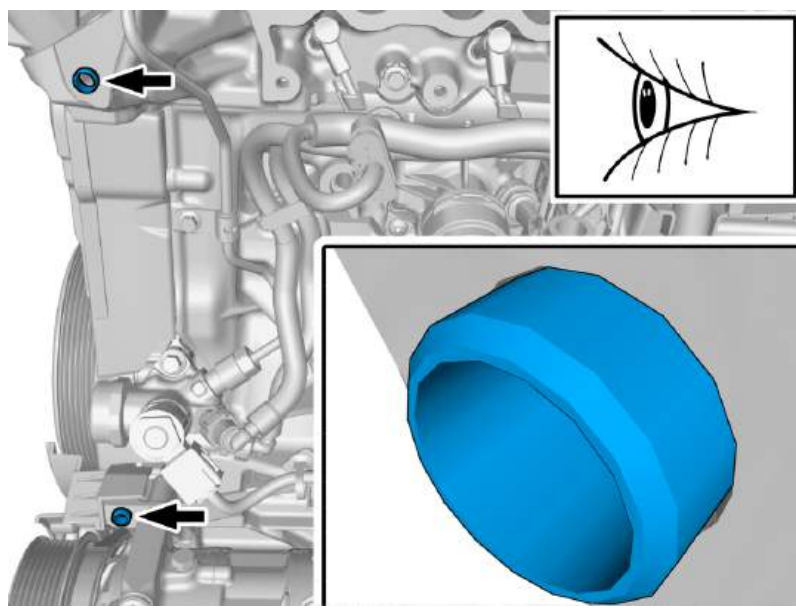

**Note!** Make sure that the component is installed.

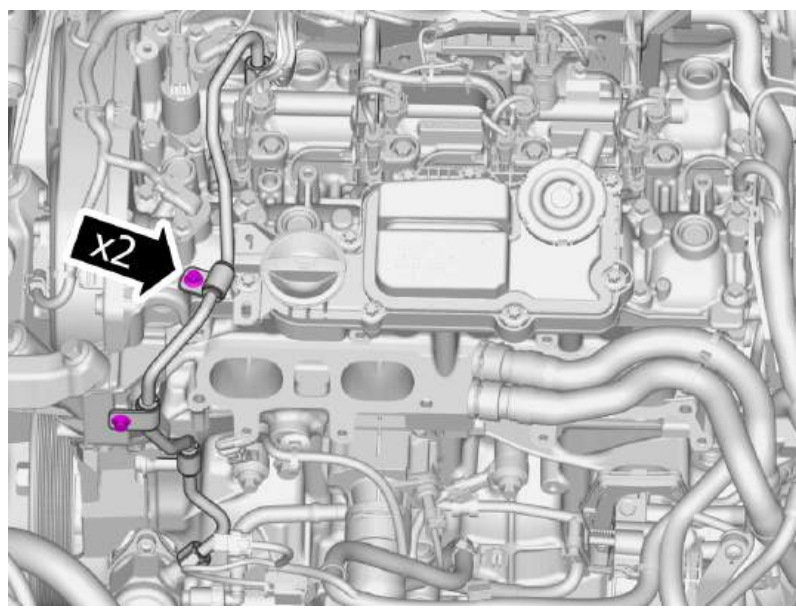

Remove the screws.

**Torque:**  
M6 , 10 Nm

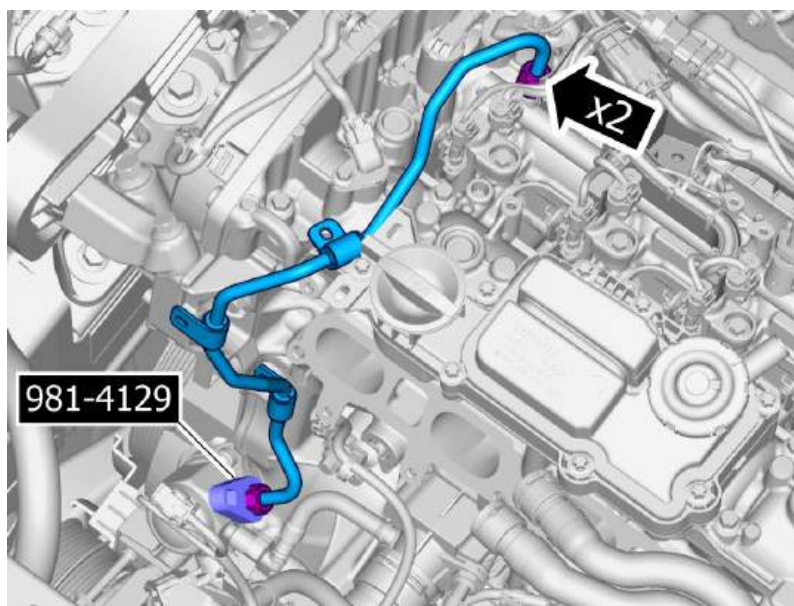

**Warning!** Be prepared to collect escaping fluid.

**Caution!** Make sure that the area around the component is clean and free of foreign material.

**Note!** Make sure that a new component is installed.

Remove the nuts.

Remove the marked part.

Special Tool: T9814129, Hook wrench

**Torque:**

- Stage 1 : High-Pressure Fuel Line to Fuel Pump , 18 Nm
- Stage 2 : High-Pressure Fuel Line to Fuel Pump , 30 Nm



Remove the Special Tool.

Release the locks.

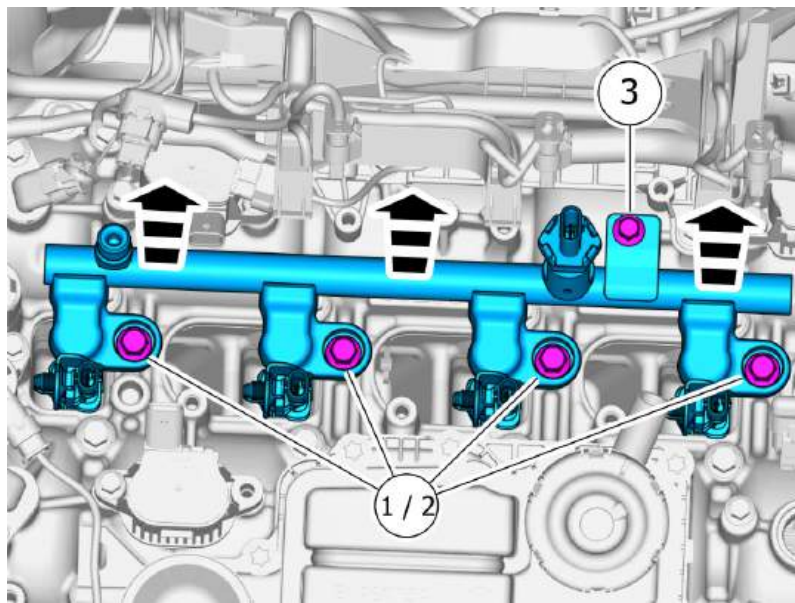
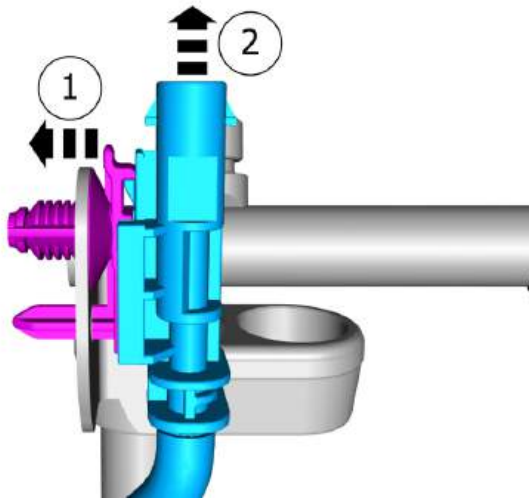

**Caution!** Make sure that the area around the component is clean and free of foreign material.

**Caution!** In order to avoid damage to the injectors, the part must be carefully pulled straight up.

**Caution!** Be extra careful when removing or installing this component.

Remove the screws.

Remove the part carefully

- 1 · **Torque:**  
Fuel rail M7 , 22 Nm
- 2 · **Torque:**  
Fuel rail M8 , 30 Nm
- 3 · **Torque:**  
M6 , 10 Nm

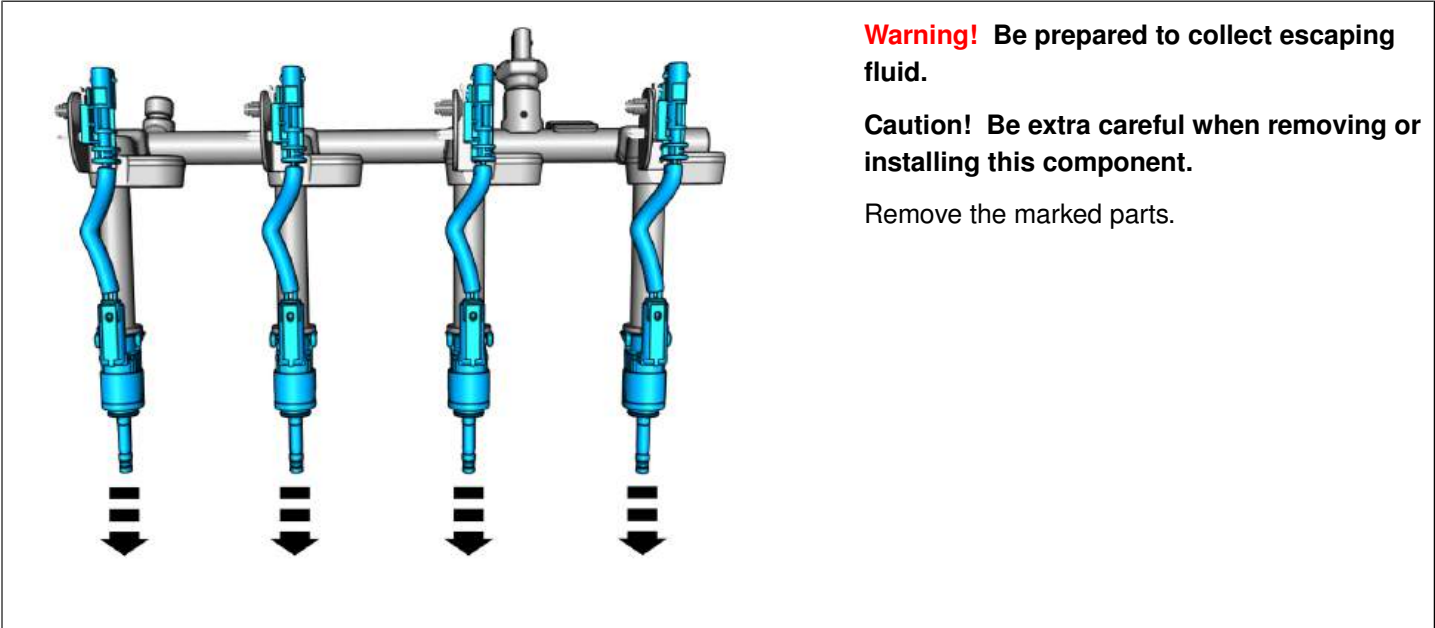

When necessary, perform the following instruction.

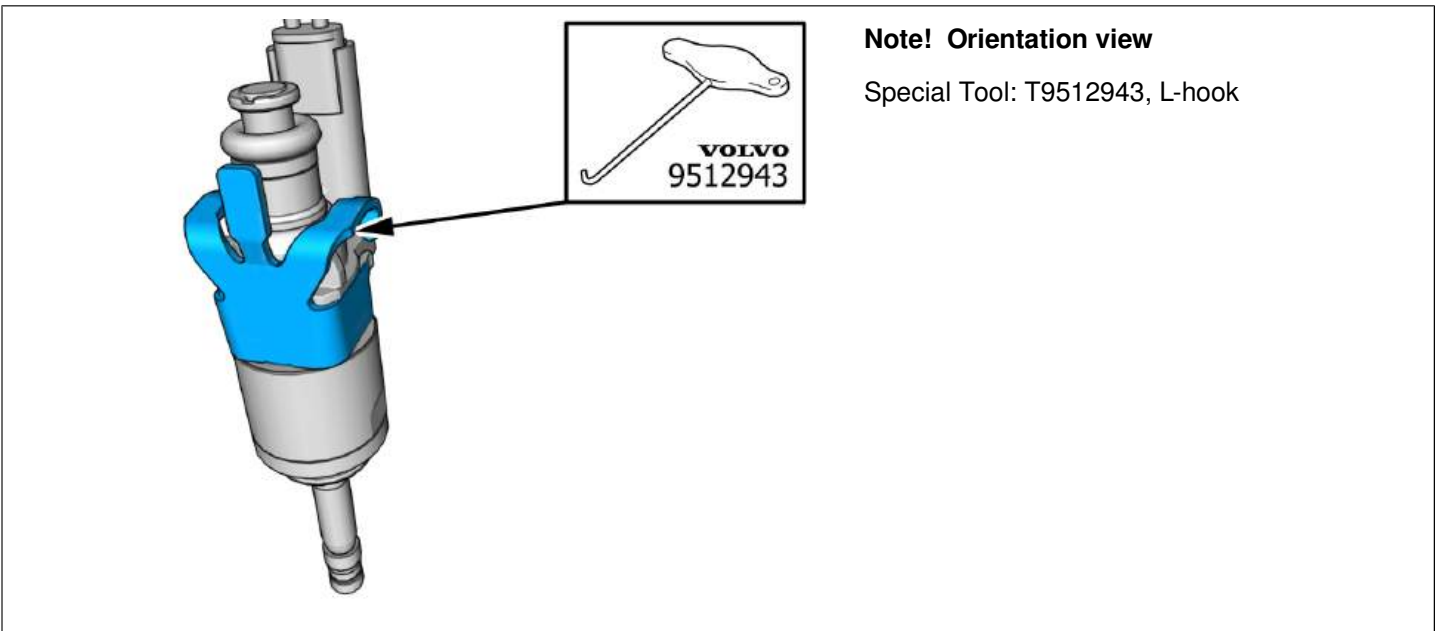

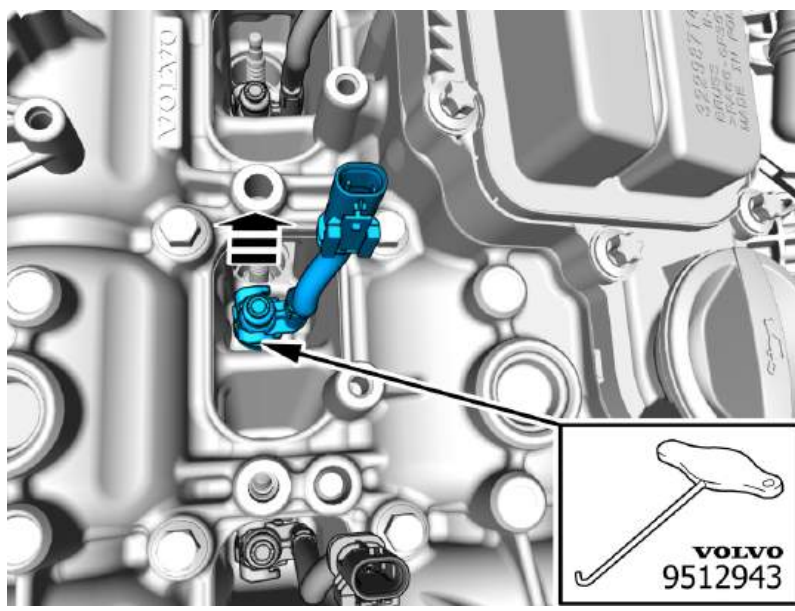

**Caution!** In order to avoid damage to the injectors, the part must be carefully pulled straight up.

**Caution!** Be extra careful when removing or installing this component.

Remove the marked part.

Special Tool: T9512943, L-hook

Replace injector seal , refer to:  
Removal, replacement and installation  
2 - Engine with mountings and equipment  
23 - Fuel system  
237 - injector and delivery pipe

**Caution!** Be extra careful when removing or installing this component.

Install the marked components.

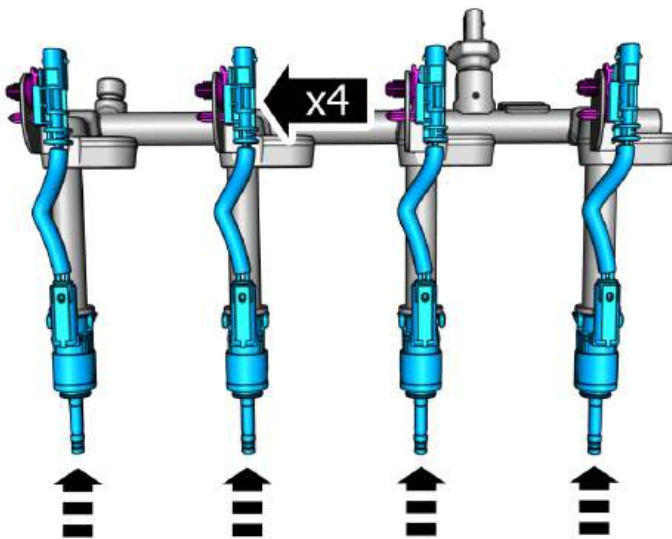

## Extra information

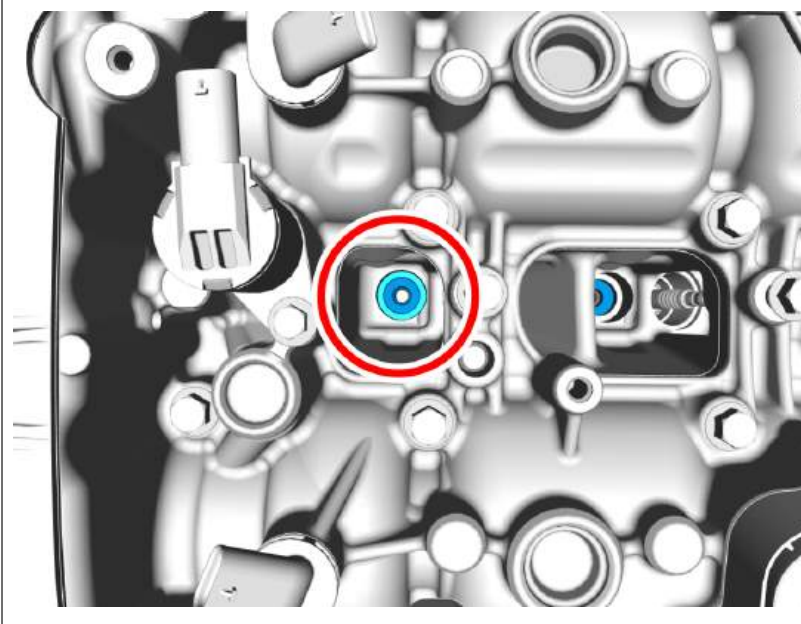

**Caution!** Make sure that the mating faces are clean and free of foreign material.

**Caution!** Clean carefully, using compressed air.

Special Tool: T9997505, Cleaning tool

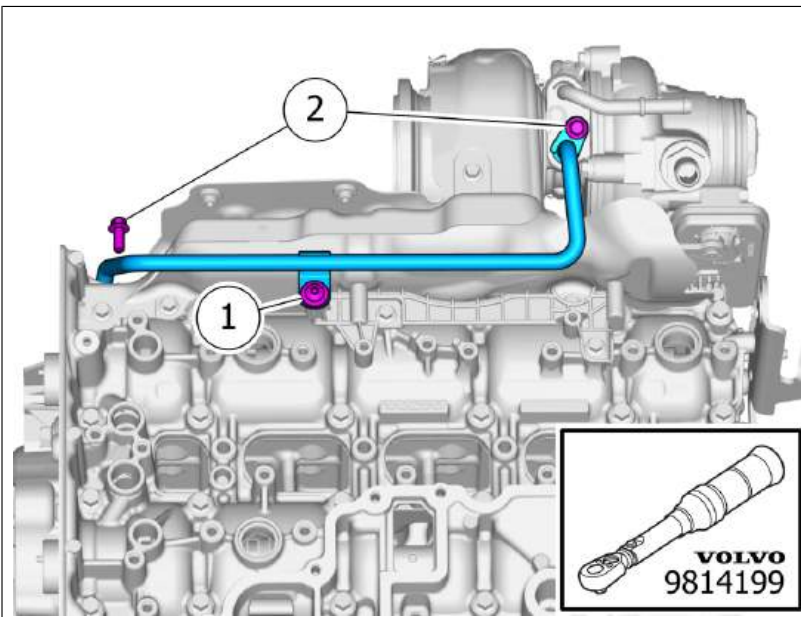

**Note!** Use new seals.

Remove the screws.

Remove the marked part.

1 · **Torque:**  
M5 , 5 Nm

2 · **Torque:**  
M6 , 10 Nm

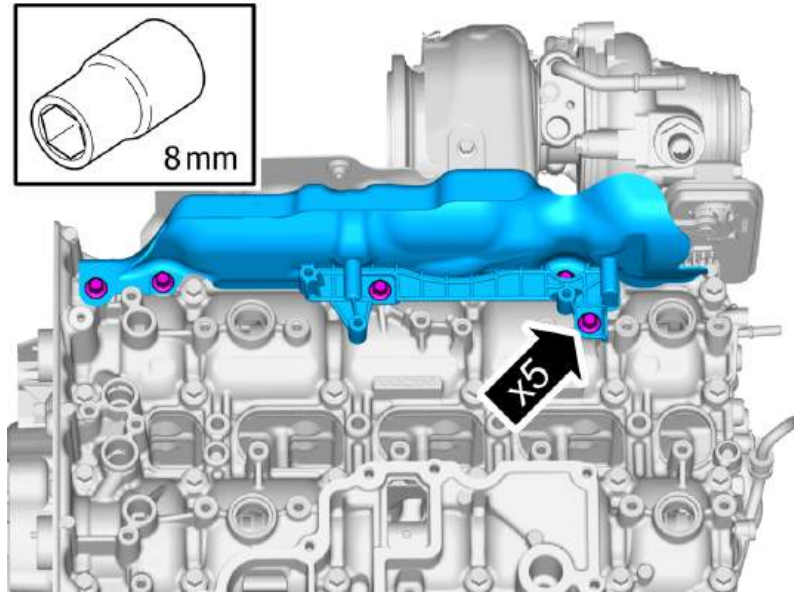
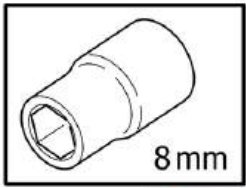

Remove the screws.  
Remove the marked part.

**Torque:**

M6 , 10 Nm

Applies to reassembly of the same component

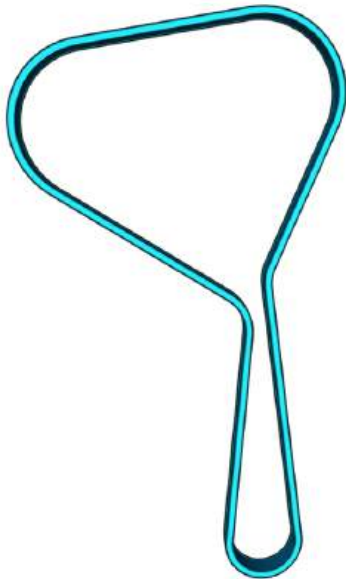

**Note!** The component can be reused unless it has been subjected to abnormal mechanical stress, damage or oil contamination.

**Caution! The part is to be reused.**



**Caution! The part is to be reused.**



**Continue the removal following the steps below.**

Remove camshaft seal , refer to:  
Removal, replacement and installation  
2 - Engine with mountings and equipment  
21 - Engine  
215 - transmission

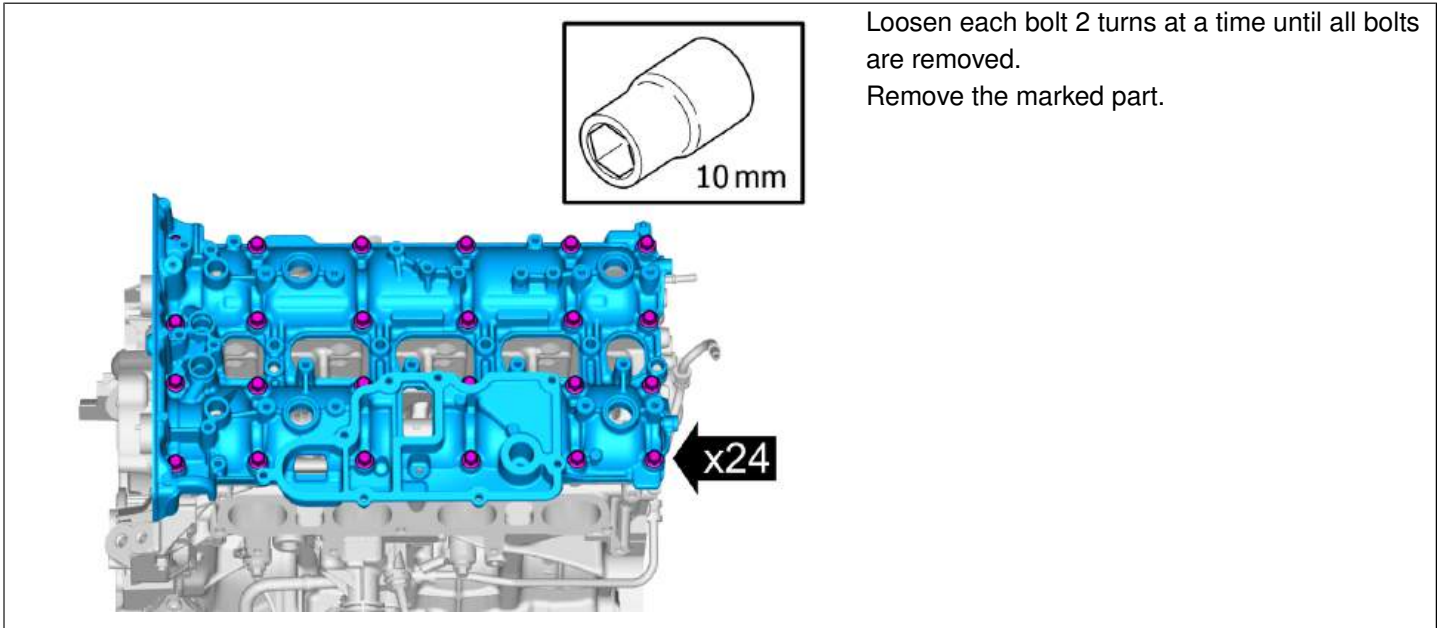

Vehicles early version

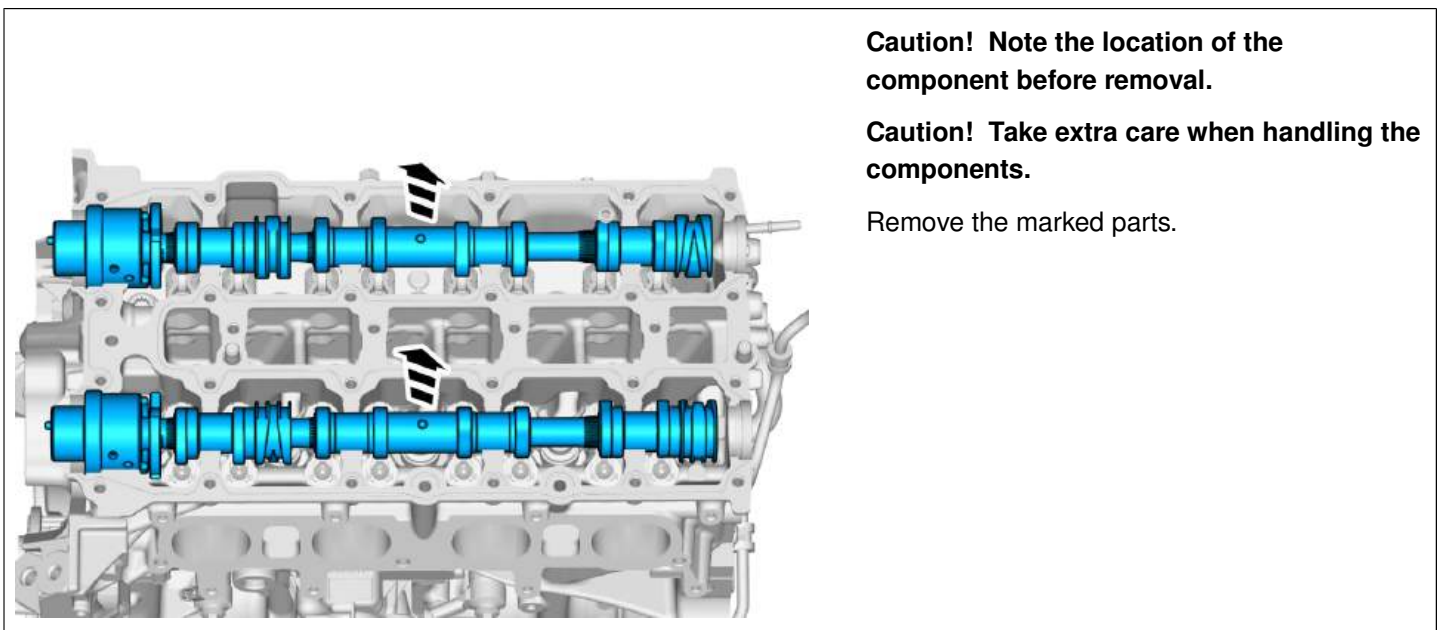

Vehicles late version

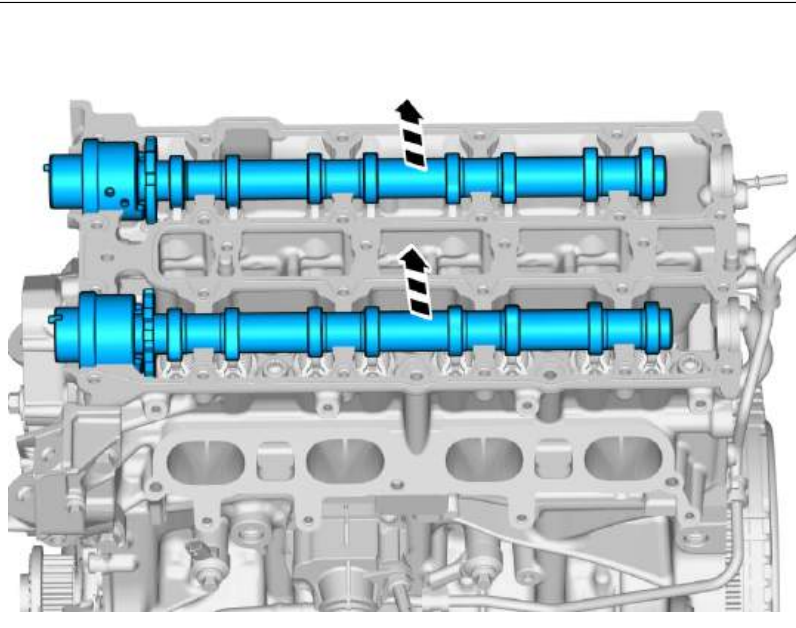

**Caution!** Note the location of the component before removal.

**Caution!** Take extra care when handling the components.

Remove the marked parts.

### Cleaning

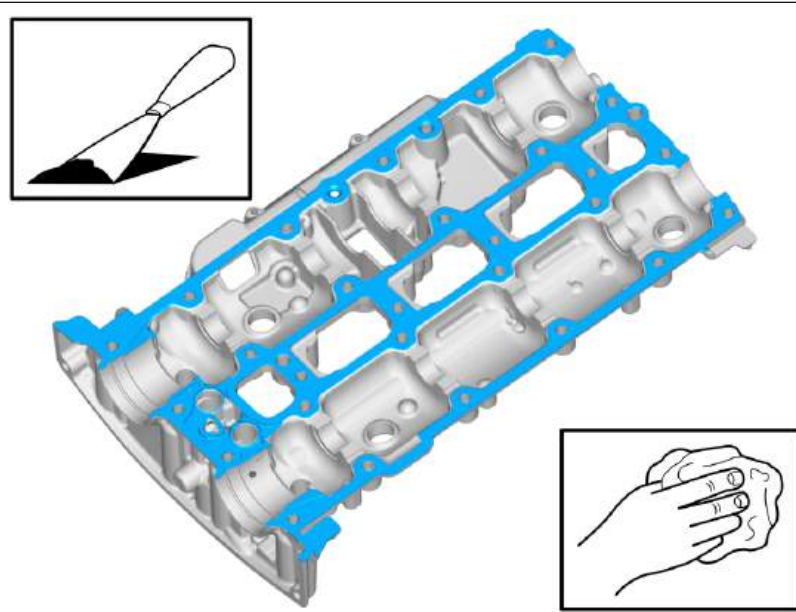

**Caution!** Take extra care not to damage the mating faces.

**Caution!** Make sure that the oil galleries are clean and free of foreign material.

**Note!** Make sure that the mating faces are clean and free of foreign material.

**Use:** Putty knife (plastic)

**Use:** Abrasive cloth , 9511024

**Use:** Isopropanol ,

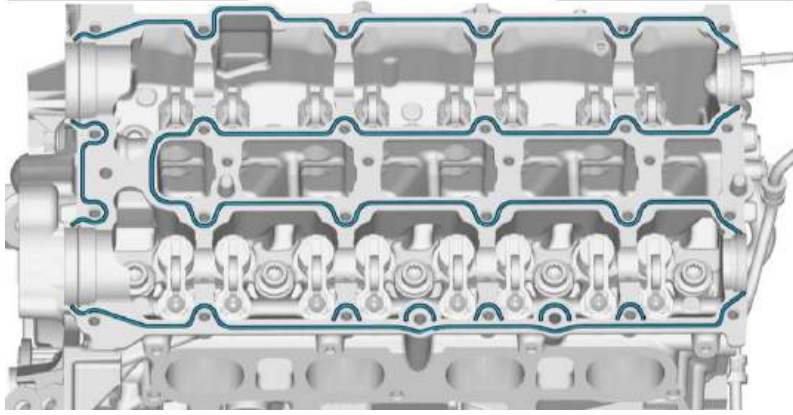

**Caution!** Take extra care not to damage the mating faces.

**Caution!** Make sure that the oil galleries are clean and free of foreign material.

**Note!** Make sure that the mating faces are clean and free of foreign material.

**Use:** Putty knife (plastic)

**Use:** Abrasive cloth , 9511024

**Use:** Isopropanol ,

### Installation

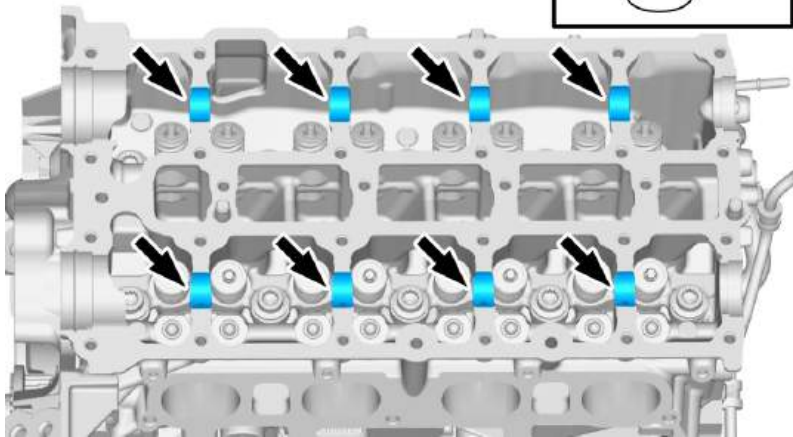

**Caution!** Make sure that the engine oil is to specification.

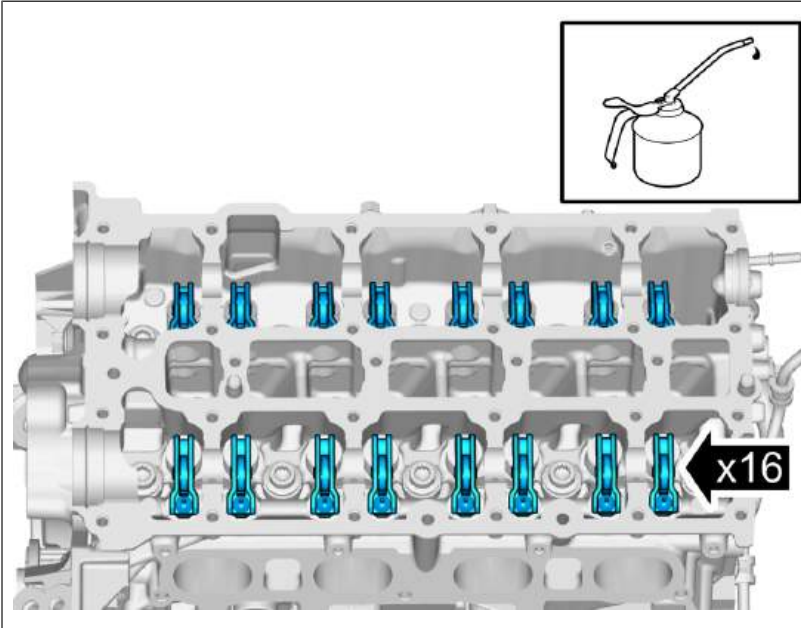

**Caution!** Make sure that the engine oil is to specification.

The following steps apply if no damages have been discovered

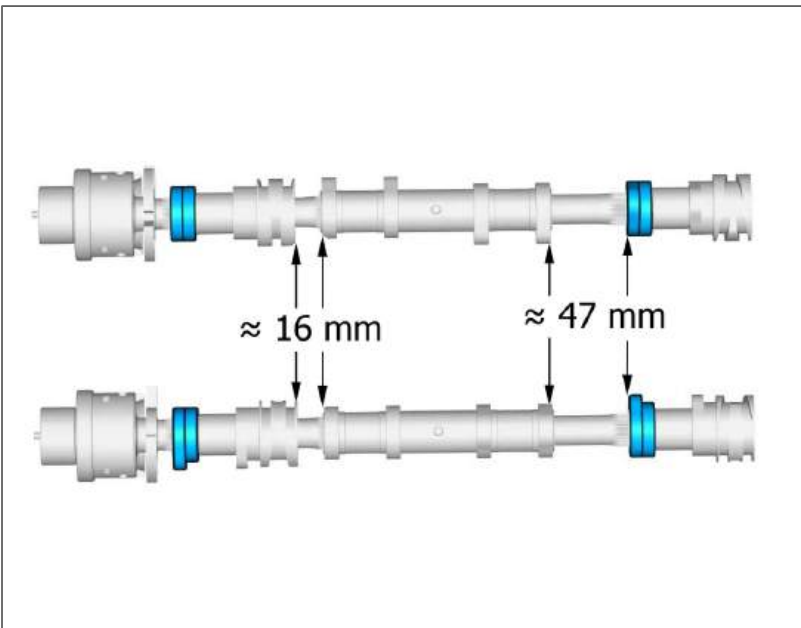

**Caution!** Make sure that the components are positioned correctly.

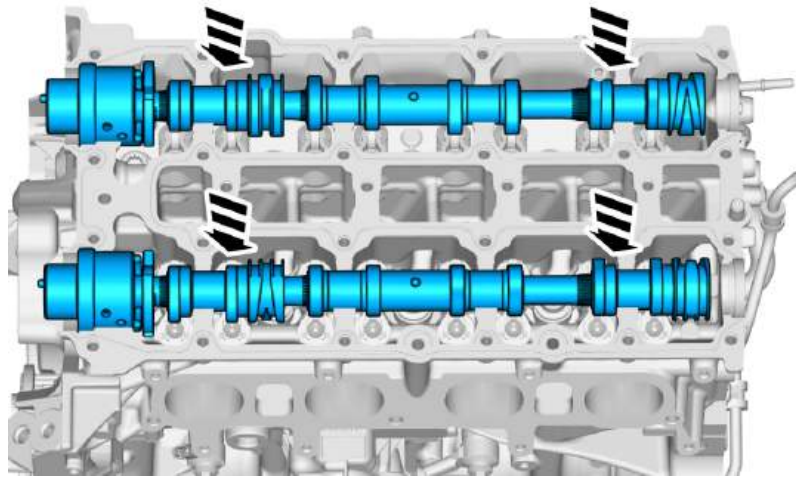

**Caution! Make sure that the components are positioned correctly.**

Install the marked component.

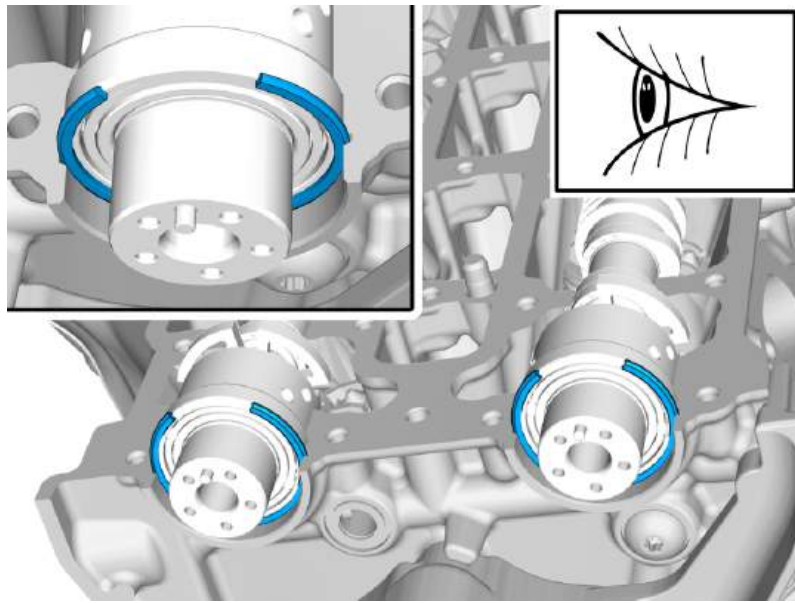

**Caution! Make sure that the components are positioned correctly.**

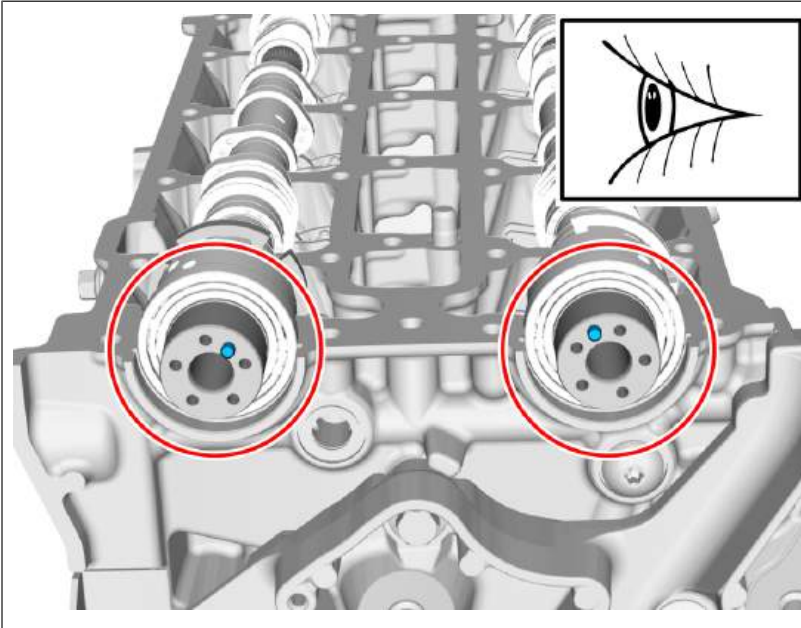

**Caution! Make sure that the components are positioned correctly.**

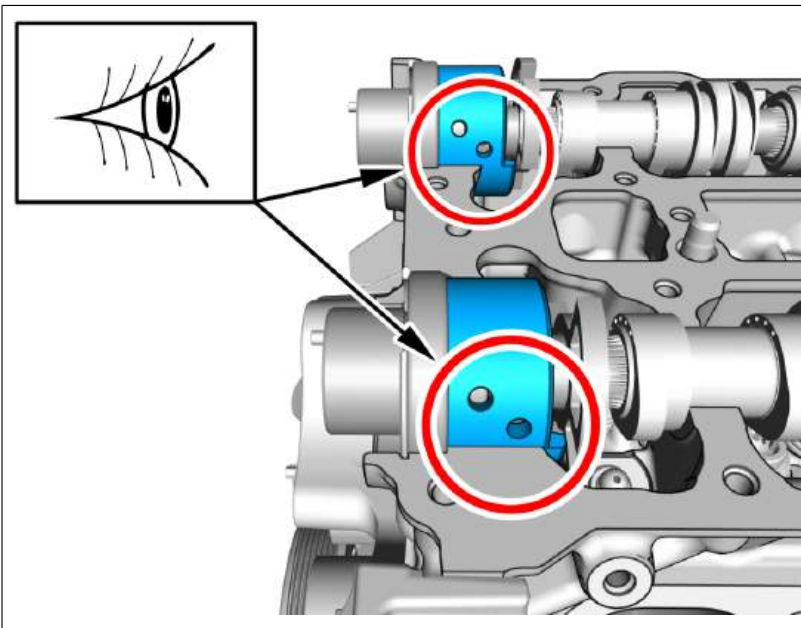

**Caution! Make sure that the components are positioned correctly.**

The following steps are performed on new component.

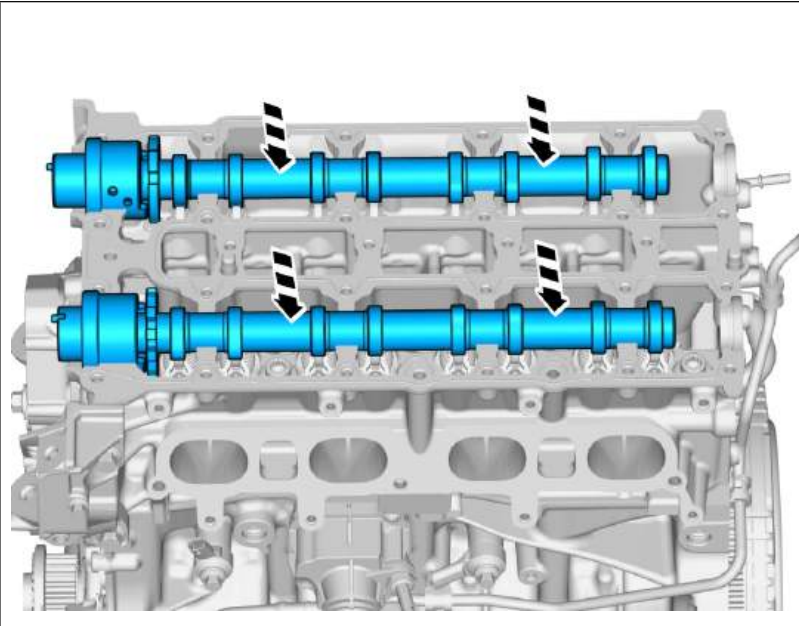

**Caution! Make sure that the components are positioned correctly.**

Install the marked components.

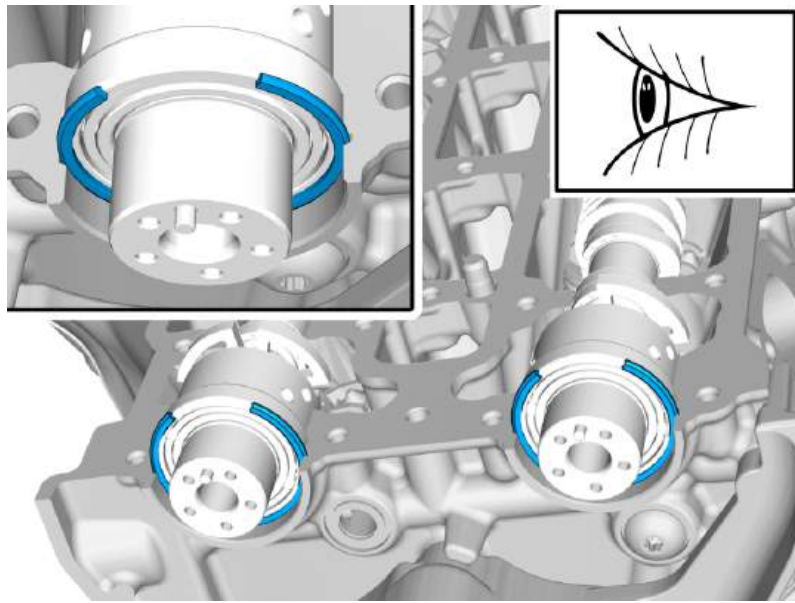

**Caution! Make sure that the components are positioned correctly.**

Install the marked components.

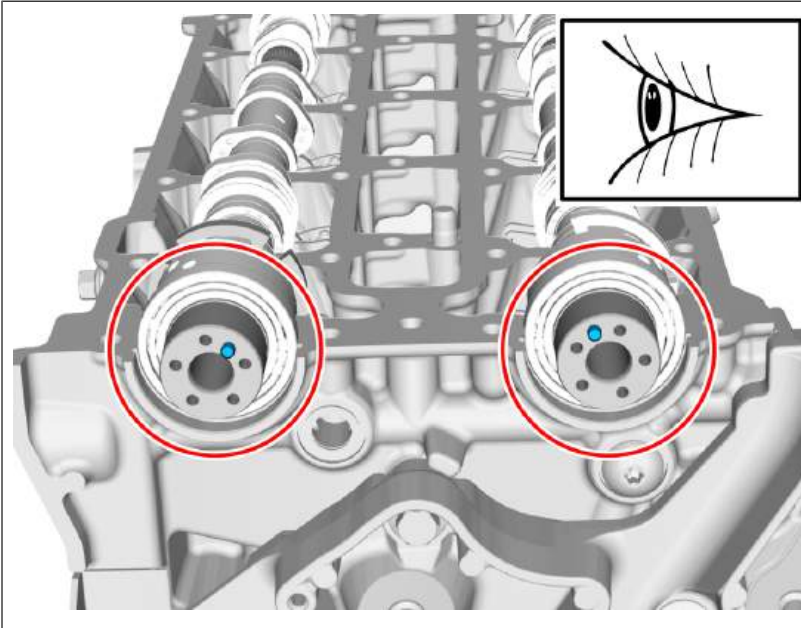

**Caution! Make sure that the components are positioned correctly.**

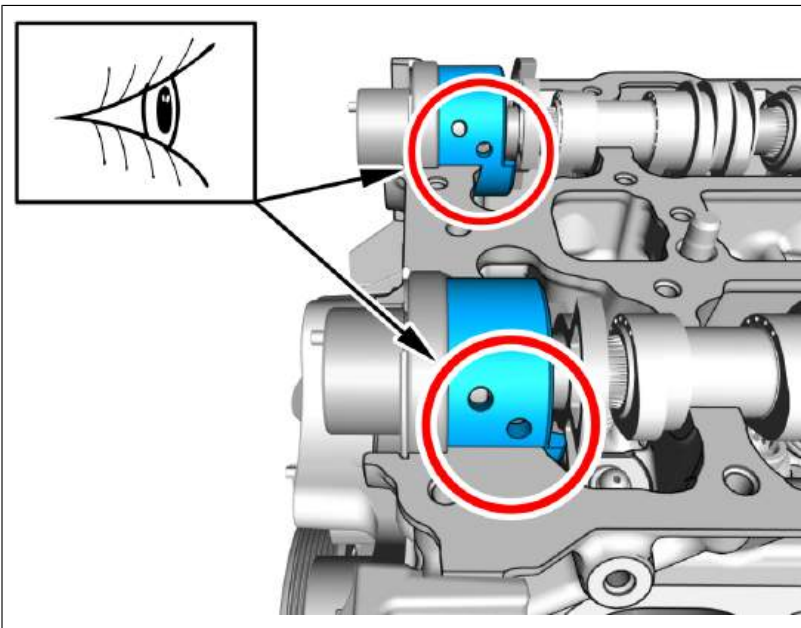

**Caution! Make sure that the components are positioned correctly.**

All vehicles

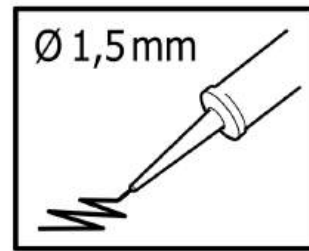
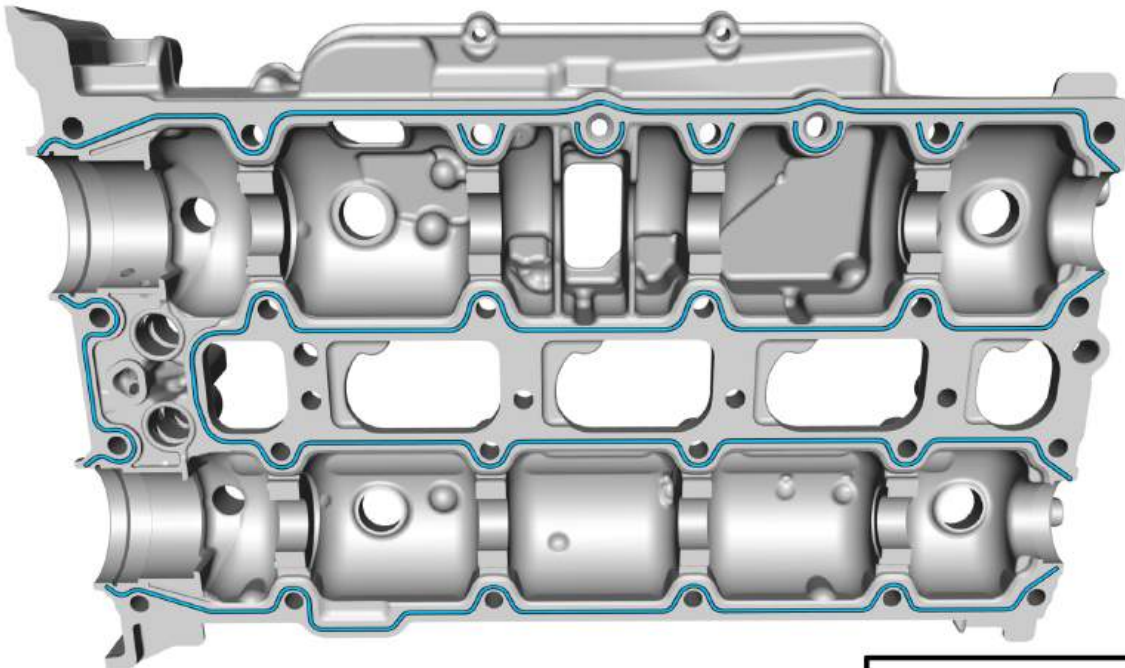

**Note!** The component must be installed within 5 minutes of applying the sealant.

**Use:** Chemical gasket , 1161771

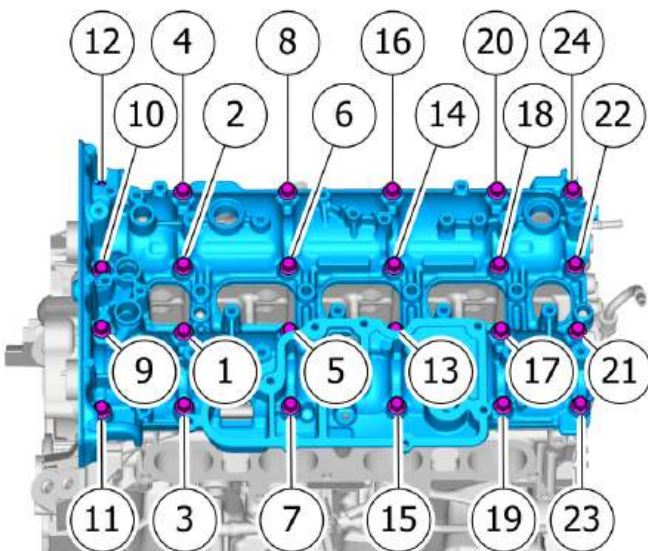

**Caution!** Make sure that equal pressure is applied to the full length of the component.

**Note!** Make sure to follow the sequence indicated.

Install the marked component.  
Install the screws.  
Tighten each bolt 2 turns at a time.

**Torque:**

M7 , 17 Nm

### Installation

To install, reverse the removal procedure.

### Check

Start the engine.

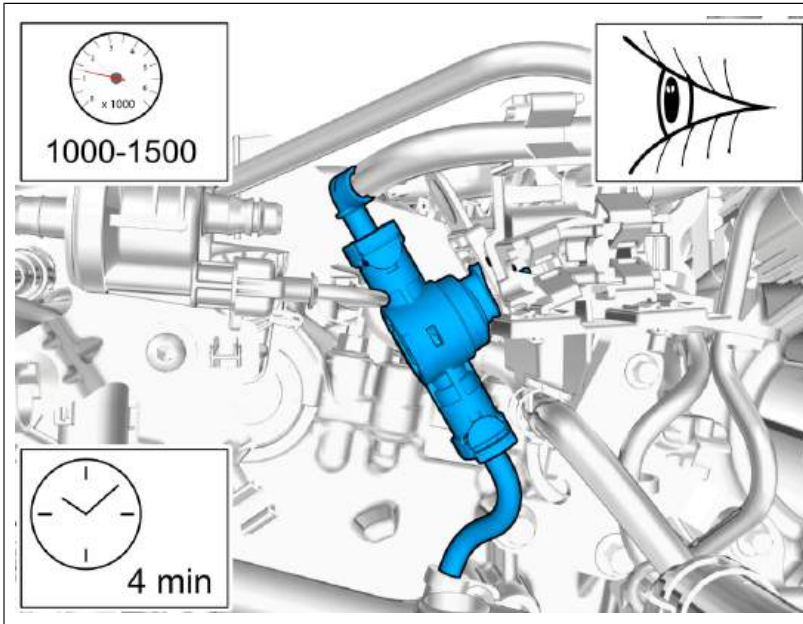

**Warning!** Make sure that there are no leaks.

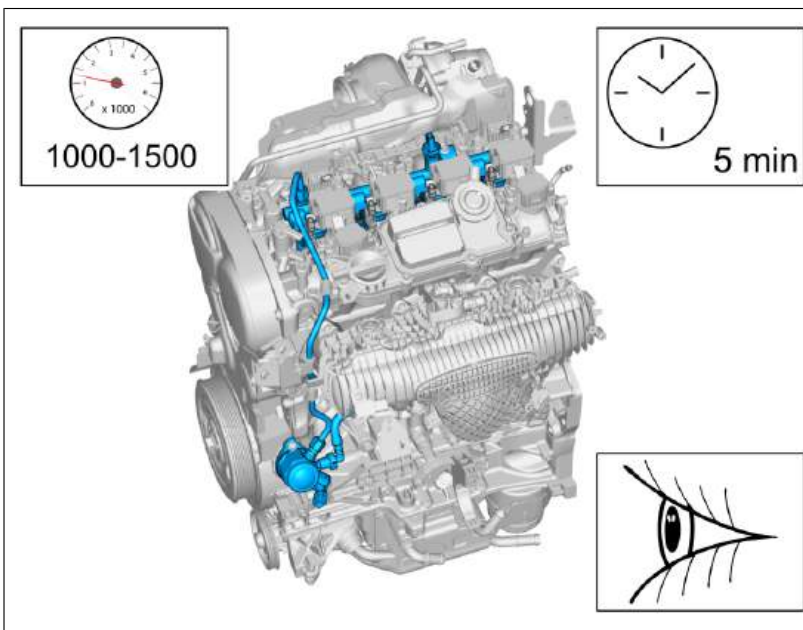

**Warning!** Make sure that there are no leaks.