



FIELD SERVICE CAMPAIGN – 26104

April 2026

SUBJECT:

Entrance Door Set Screw Replacement.

MODELS INVOLVED:

Next Generation IC Bus™ CE Series buses (PB11000, PC11000) built 2/5/2024 through 6/5/2025.

DEFECT DESCRIPTION:

Entrance door set screw may loosen over time and with use.

TOOLS REQUIRED:

Description	Tool Number
5/16 in-24 tap	Source locally
0.272 in Diameter Letter "I" Drill Bit	Source locally
Drill	Source locally

Table 1 Tools Information

PARTS REQUIRED:

Part Number	Description	Quantity
2527197C1	5/16 in-24 Carbon Steel Set Screw	2
476074C1	Nut, Battery terminal 3/8 in UNC	1

Table 2 Parts Information

SERVICE PROCEDURE

WARNING! To prevent personal injury and / or death, or damage to property, park vehicle on hard flat surface, turn the engine off, set the parking brake and install wheel chocks to prevent the vehicle from moving in either direction.

WARNING! To prevent personal injury and / or death, or damage to property, if the vehicle must be raised, do not work under the vehicle supported only by jacks. Jacks can slip or fall over.

WARNING! To prevent personal injury and / or death, always wear safe eye protection when performing vehicle maintenance.

WARNING! To prevent personal injury and / or death, or damage to property, allow engine / vehicle components to cool before servicing.

WARNING! To prevent personal injury and / or death, or damage to property, keep flames or sparks away from vehicle and do not smoke while servicing the vehicle's batteries. Batteries expel explosive gases.

WARNING! To prevent personal injury and / or death, or damage to property, remove the ground cable from the negative terminal of the battery box before disconnecting any electrical components. Always connect the ground cable last.

1. Park vehicle on flat surface with wheels straight ahead.
2. Shift transmission to Park or Neutral and set parking brakes.
3. Turn vehicle ignition to Key OFF position.
4. Install wheel chocks.
5. Drain air tanks, if equipped.
6. Disconnect and isolate the negative battery terminal.

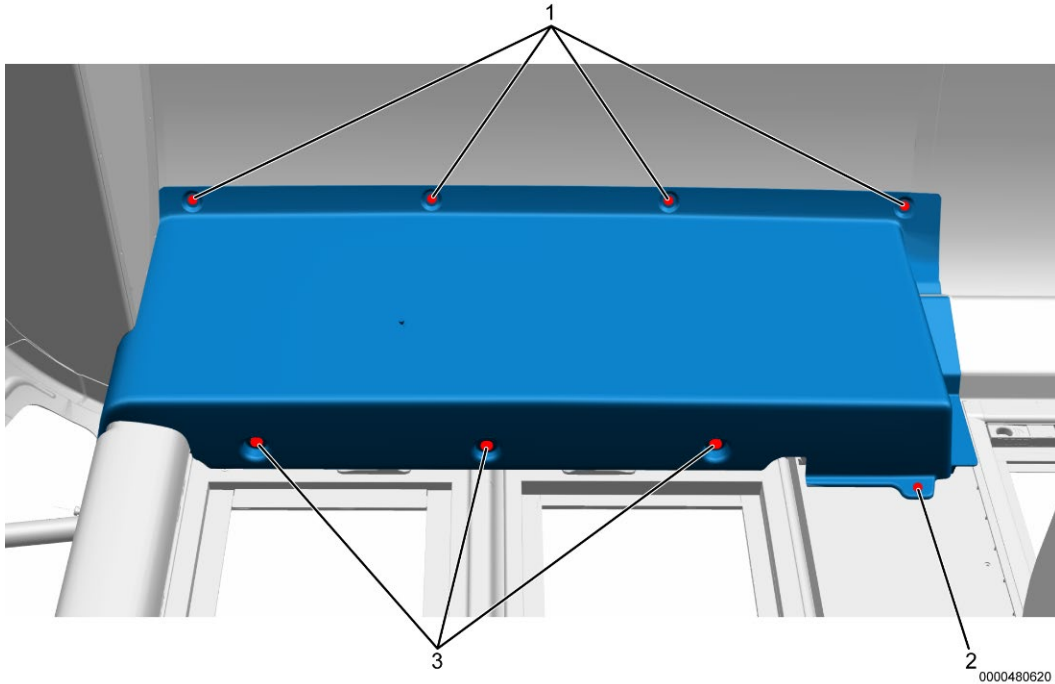
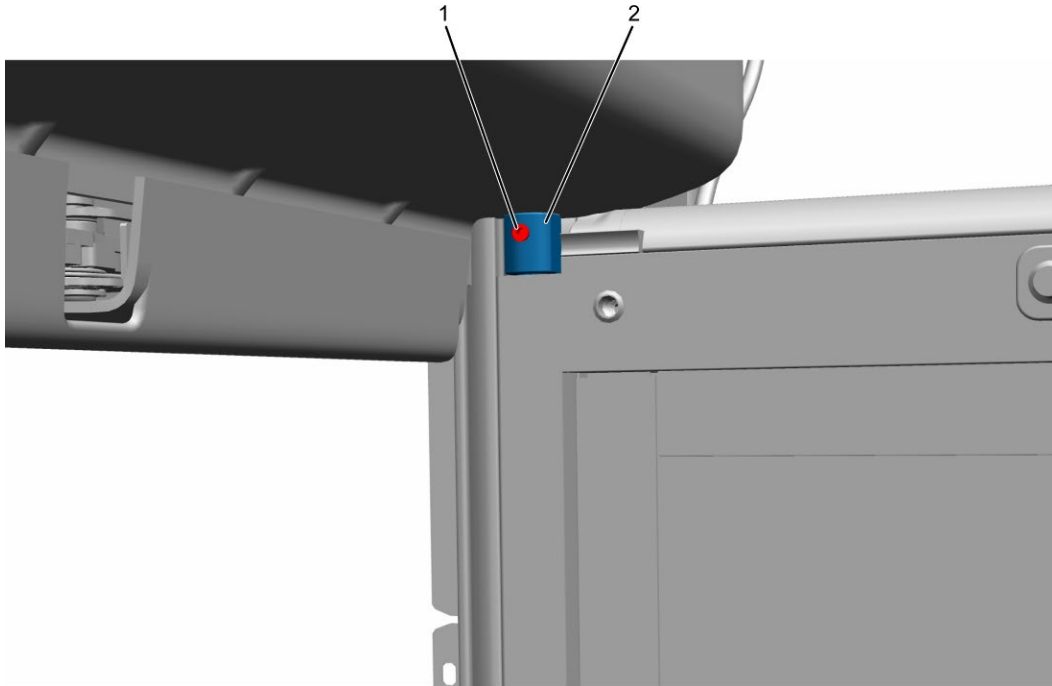

Figure 1. Entry Door Overhead Compartment

1. 8 mm push-in fastener (4)
 2. 12–14 x 0.75 mm pan head Torx screw
 3. M6 x 20 mm flanged Torx screw (3)
7. Remove four 8 mm push-in fasteners (Figure 1, Item 1) from entry door overhead compartment.
 8. Remove three M6 x 20 mm flanged Torx screws (Figure 1, Item 3) and one 12–14 x 0.75 mm pan head Torx screw (Figure 1, Item 2) from entry door overhead compartment, then remove the panel for access.
 9. Confirm if the bus entry door is air actuated or electric.
 - a. If the bus entry door is air actuated, proceed to Step 10.
 - b. If the bus entry door is electrically actuated, proceed to Step 31.

AIR ACTUATOR REPAIR PROCEDURE



0000481034

Figure 2. Entrance Door Collar

1. Allen set screw
2. Door collar

10. Loosen Allen set screw (Figure 2, Item 1) located on door collar (Figure 2, Item 2) to allow pivots to be removed from door collar. Repeat for both entrance doors.

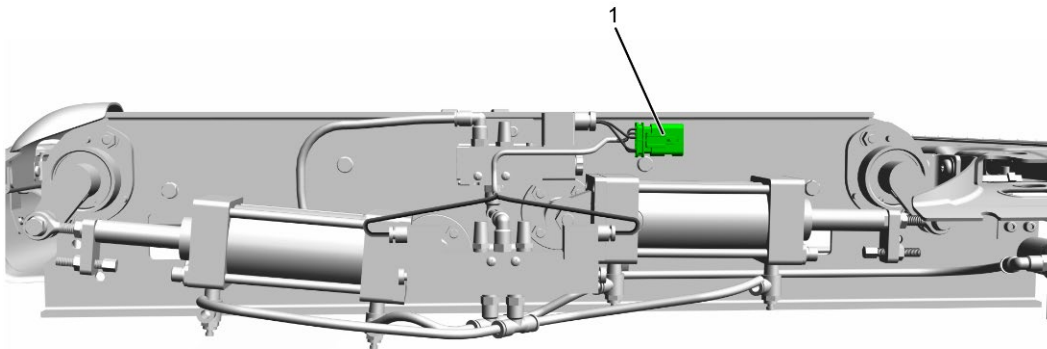

0000484197

Figure 3. Pneumatic Actuator Electrical Connector

1. Electrical connector

11. Disconnect electrical connector (Figure 3, Item 1).

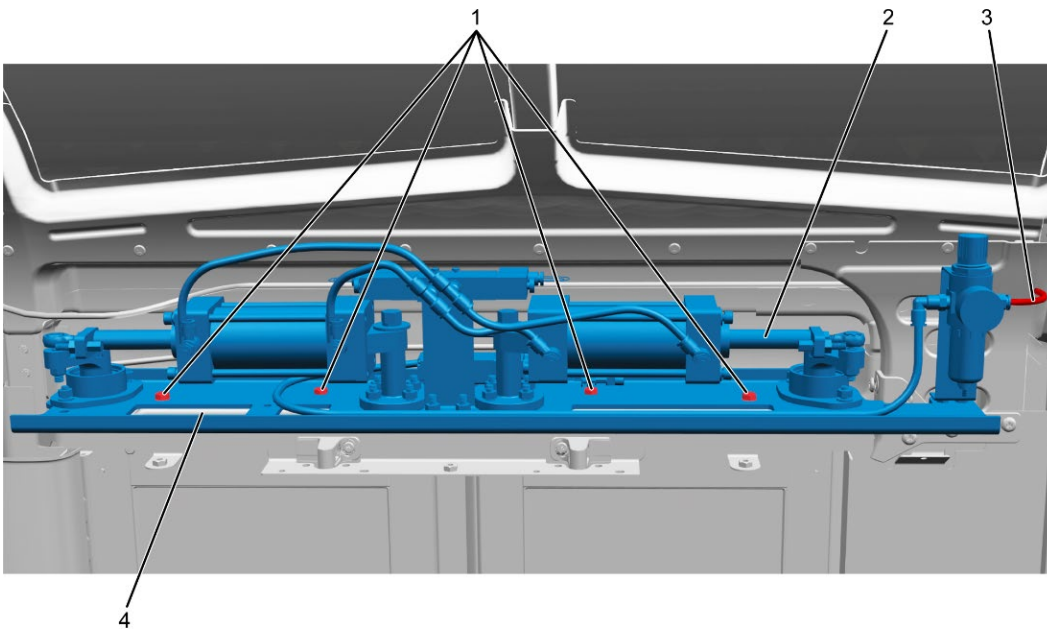

0000477213

Figure 4. Entrance Door Air Actuator

1. M8 x 16 bolt (4)
2. Entrance door pneumatic actuator assembly
3. Entrance door pneumatic actuator air line
4. Mounting plate

12. Disconnect entrance door pneumatic actuator air line (Figure 4, Item 3).

13. Remove four M8 x 16 bolts (Figure 4, Item 1) from pneumatic actuator assembly mounting plate (Figure 4, Item 4).

14. Remove entrance door pneumatic actuator assembly (Figure 4, Item 2) with mounting plate (Figure 4, Item 4).

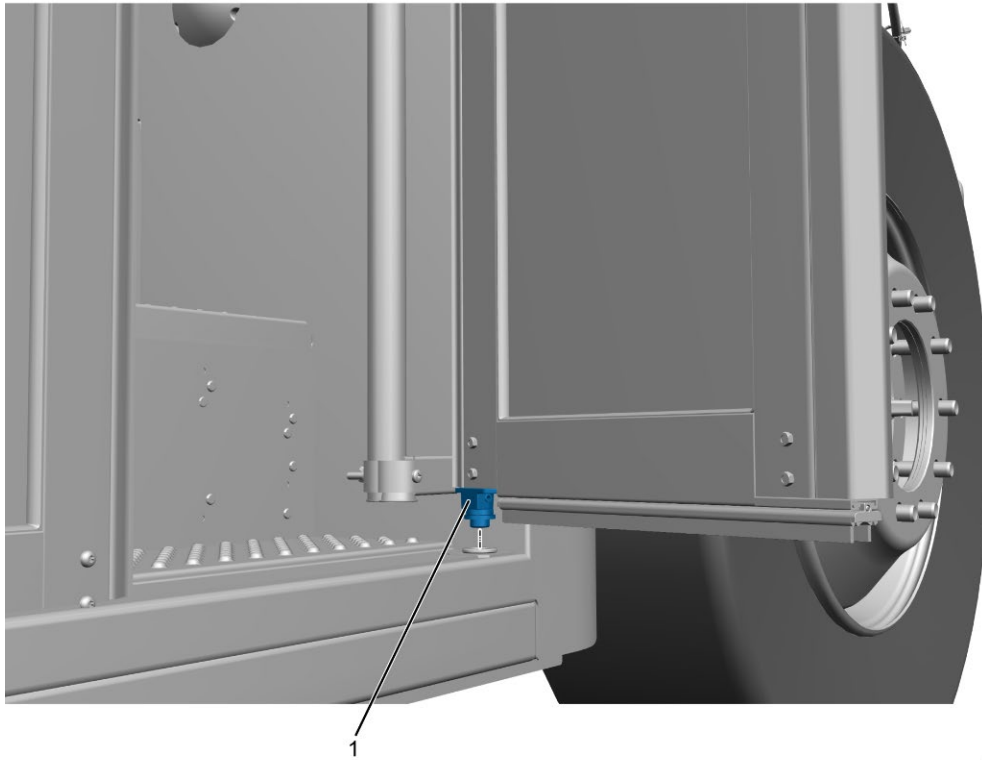

0000490373

Figure 5. Entrance Door Lower Male Hinge

1. Lower male hinge

15. With entrance door in an open position, gently lift entrance door up to release lower male hinge (Figure 5, Item 1).

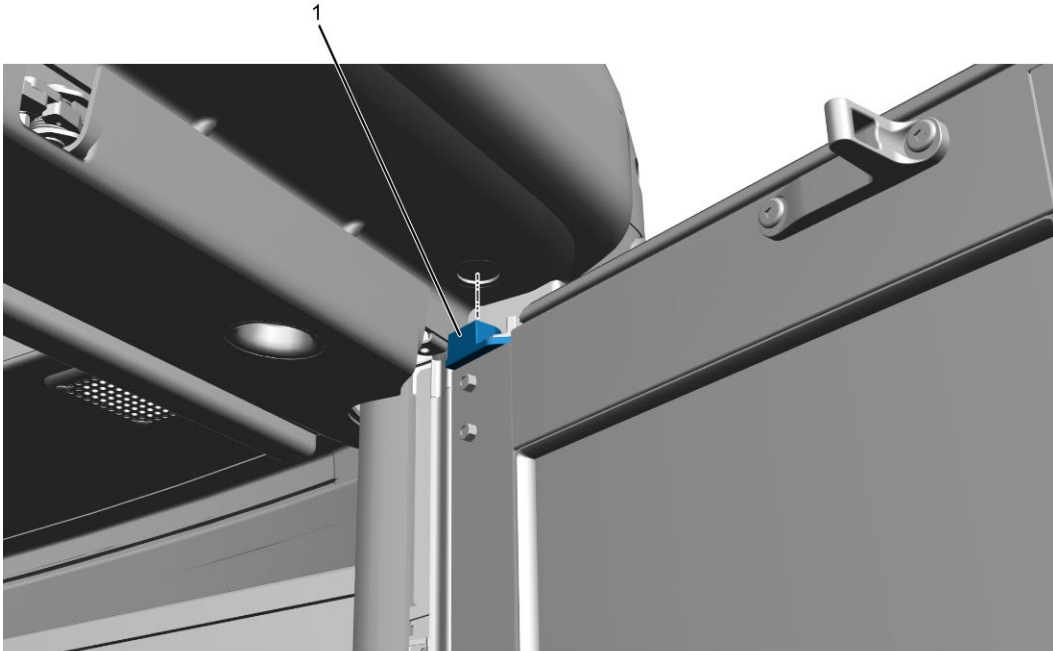

0000490379

Figure 6. Entrance Door Upper Female Hinge

1. Upper female hinge

16. Gently tilt and lower door out of frame to release the upper female hinge (Figure 6, Item 1).
17. Place door flat on a protected surface.

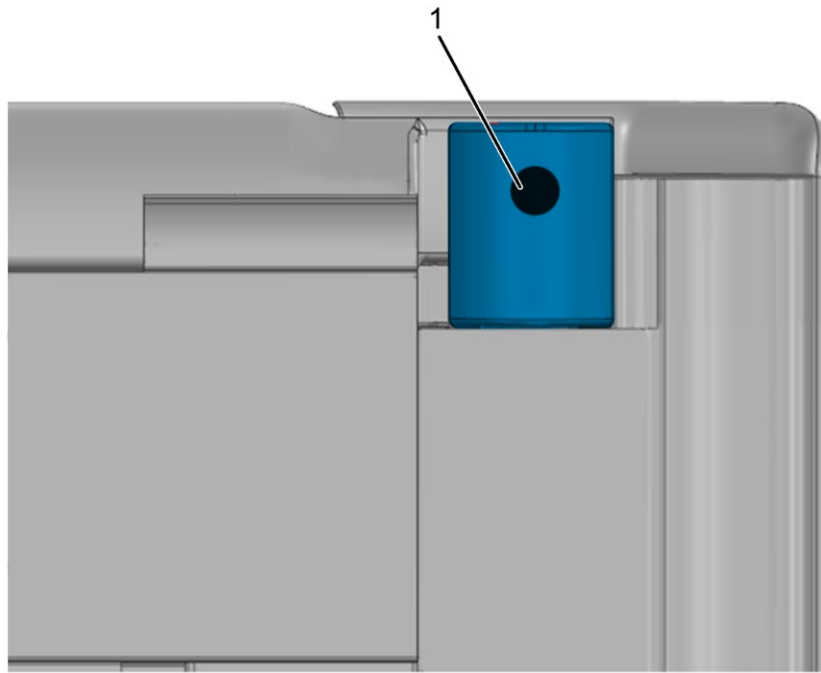

0000494479

Figure 7. Set Screw Location

1. Set screw hole

18. Drill a new hole where the set screw was (Figure 7, Item 1), ensuring it is straight as possible. The new hole should have a 0.272 in diameter.
19. Tap the new hole with a 5/16 in-24 tap. Deburr and remove any metal shavings.
20. Partially insert the new 5/16 in-24 set screws into the new threaded hole.
21. Repeat Steps 15–20 for the other door leaf.

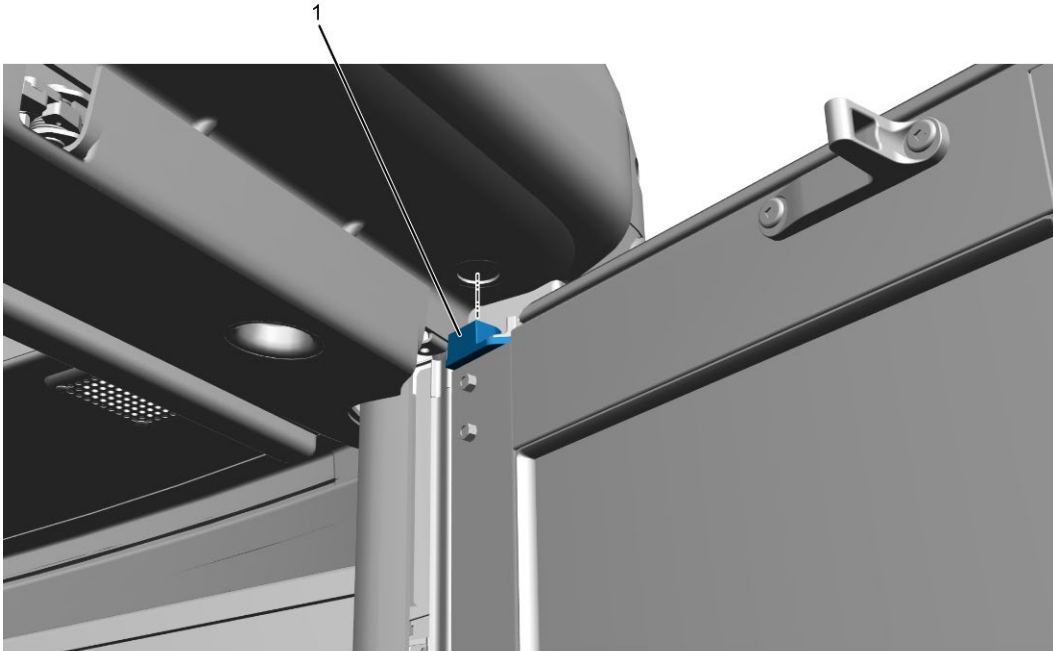

0000490379

Figure 8. Entrance Door Upper Female Hinge

1. Upper female hinge

22. Gently tilt and raise door into frame ensuring that upper female hinge (Figure 8, Item 1) slides into place.

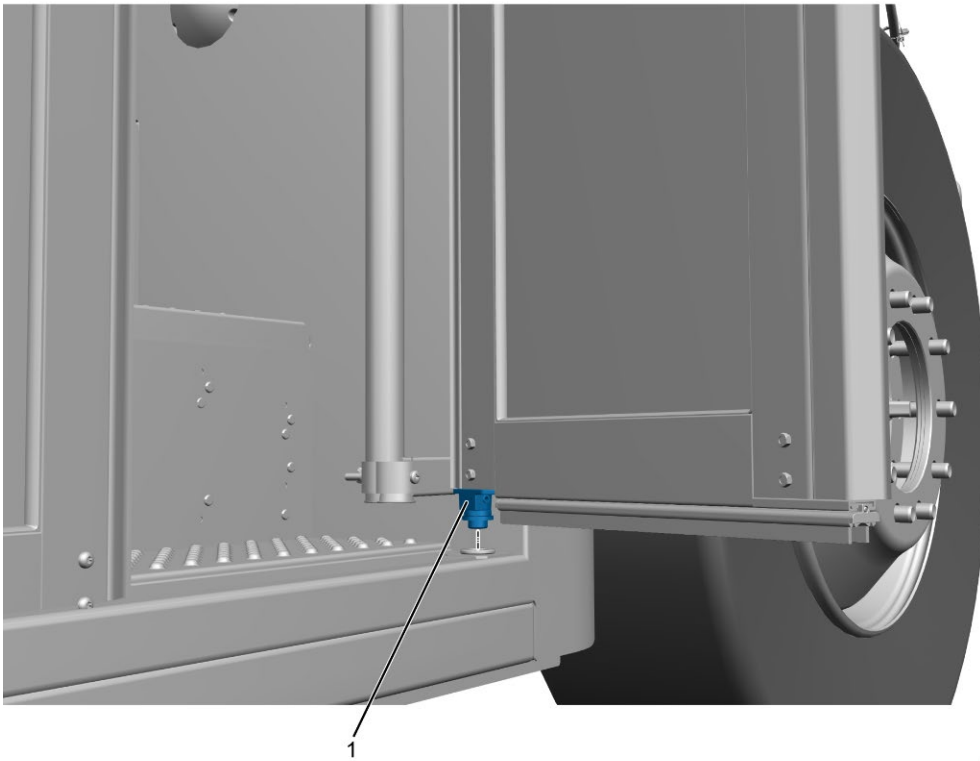

0000490373

Figure 9. Entrance Door Lower Male Hinge

1. Lower male hinge

23. With entrance door in an open position, gently lift entrance door up to insert lower male hinge (Figure 9, Item 1).

24. Repeat Steps 22–23 for the other door leaf.

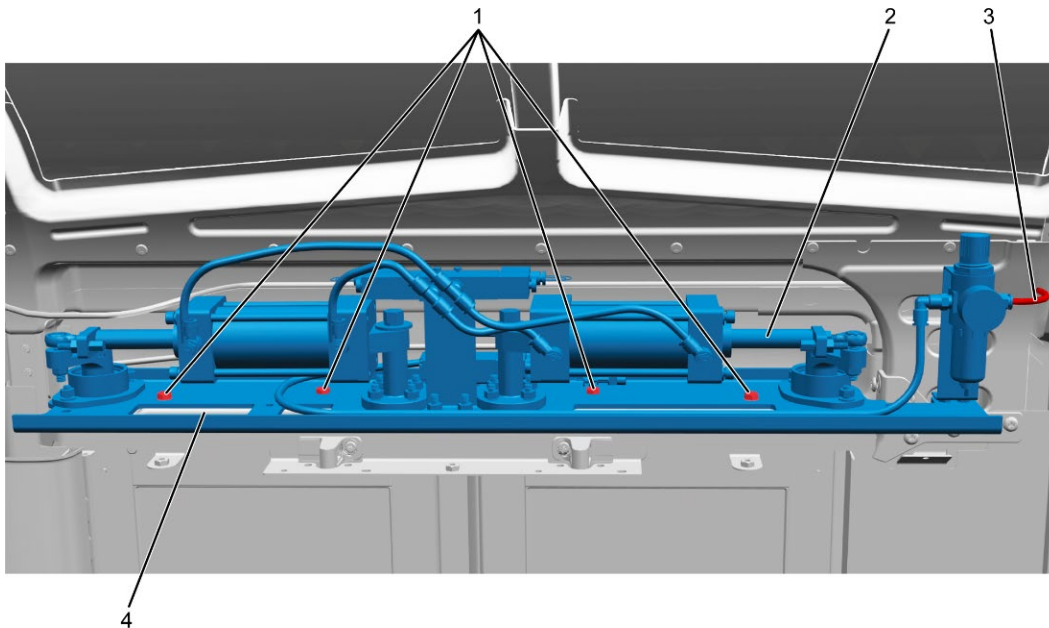

0000477213

Figure 10. Entrance Door Pneumatic Actuator

1. M8 x 16 bolt (4)
2. Entrance door pneumatic actuator
3. Entrance door pneumatic actuator air line
4. Mounting plate

25. Place pneumatic actuator assembly above door frame, ensuring that the door pivots are seated within door collar.
26. Secure pneumatic actuator assembly with four M8 x 16 bolts (Figure 10, Item 1) and tighten to 23–26 lb-ft (31–35 N·m).
27. Install entrance door pneumatic actuator air line (Figure 10, Item 3).

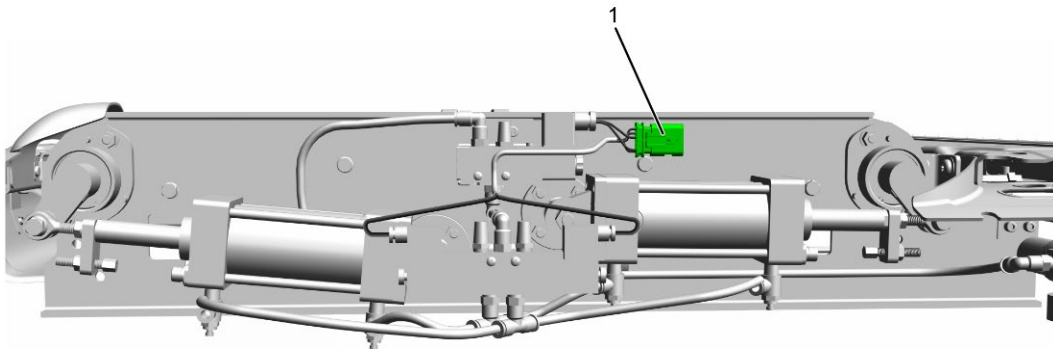

0000484197

Figure 11. Pneumatic Actuator Electrical Connector

1. Electrical connector

28. Install electrical connector (Figure 11, Item 1).

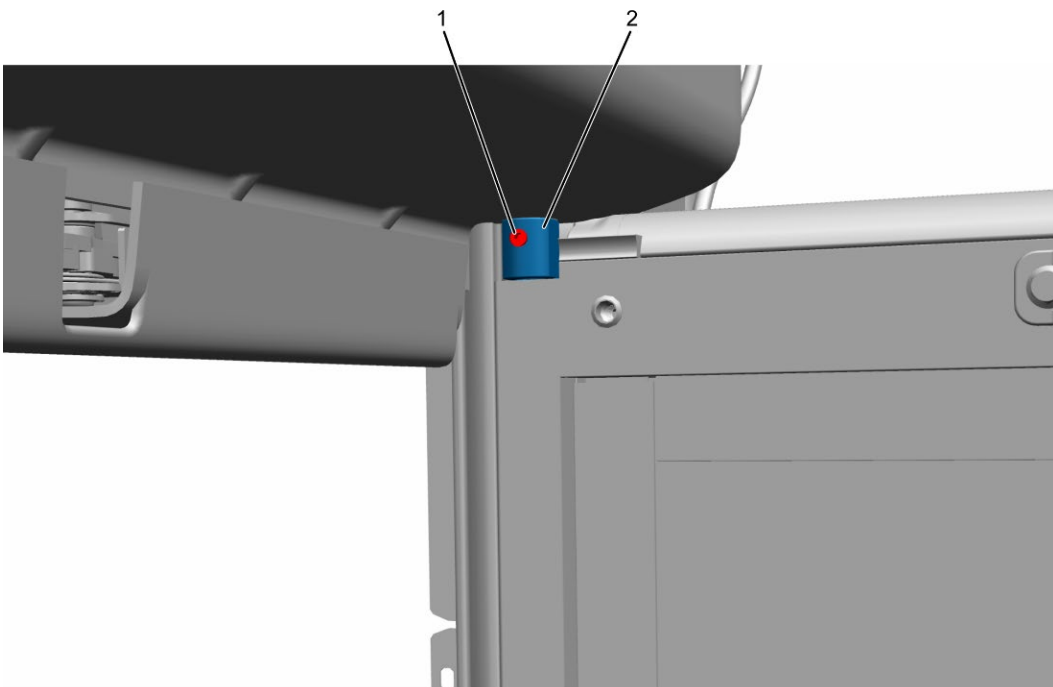

0000481034

Figure 12. Entrance Door Collar

1. Set screw
2. Door collar

29. Tighten set screw (Figure 12, Item 1) located on door collar (Figure 12, Item 2) to 200 lb-in (22.6 N·m). Repeat for both entrance doors.

30. Proceed to Step 51.

ELECTRIC ACTUATOR REPAIR PROCEDURE

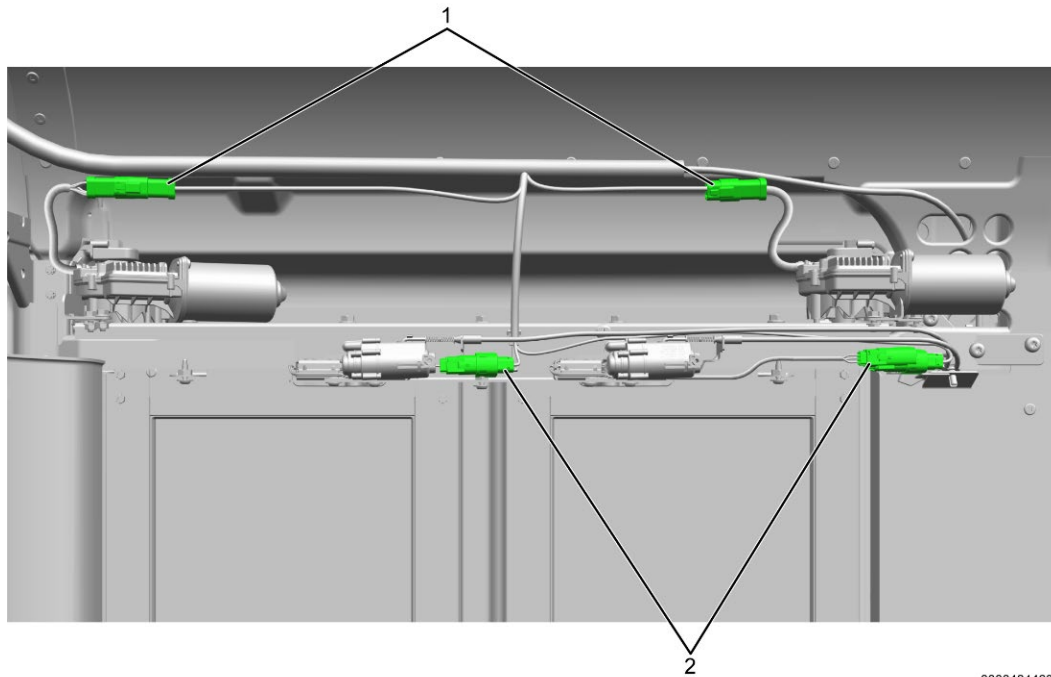

0000484463

Figure 13. Electric Door Motor Electric Connections

1. Electric motor connector (2)
2. Door latch connector (2)

31. Disconnect two door latch connectors (Figure 13, Item 2).

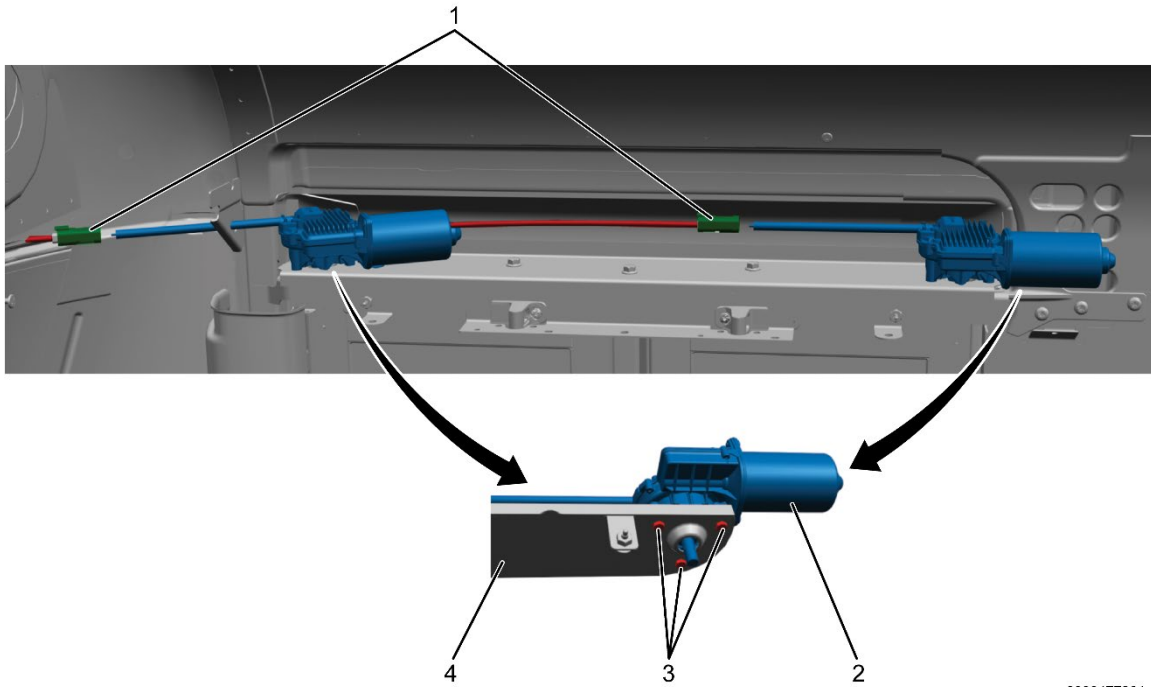

0000477201

Figure 14. Entrance Door Electric Motor

- 1. Electric motor connector (2)
- 2. Entrance door electric motor (2)
- 3. M6 x 20 hex bolt (6, 3 shown)
- 4. Mounting support plate

32. Disconnect two electric motor connectors (Figure 14, Item 1), removing and discarding cable ties as necessary.

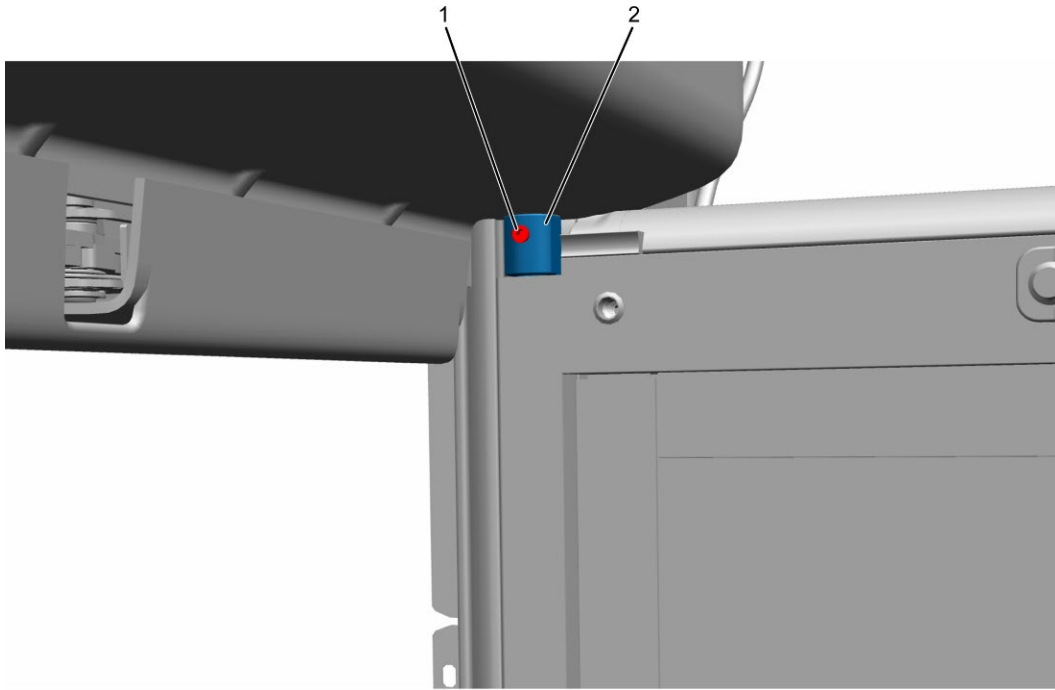

0000481034

Figure 15. Entrance Door Collar

1. Set screw
2. Door collar

33. Loosen set screw (Figure 15, Item 1) located on door collar (Figure 15, Item 2). Repeat for both entrance doors.

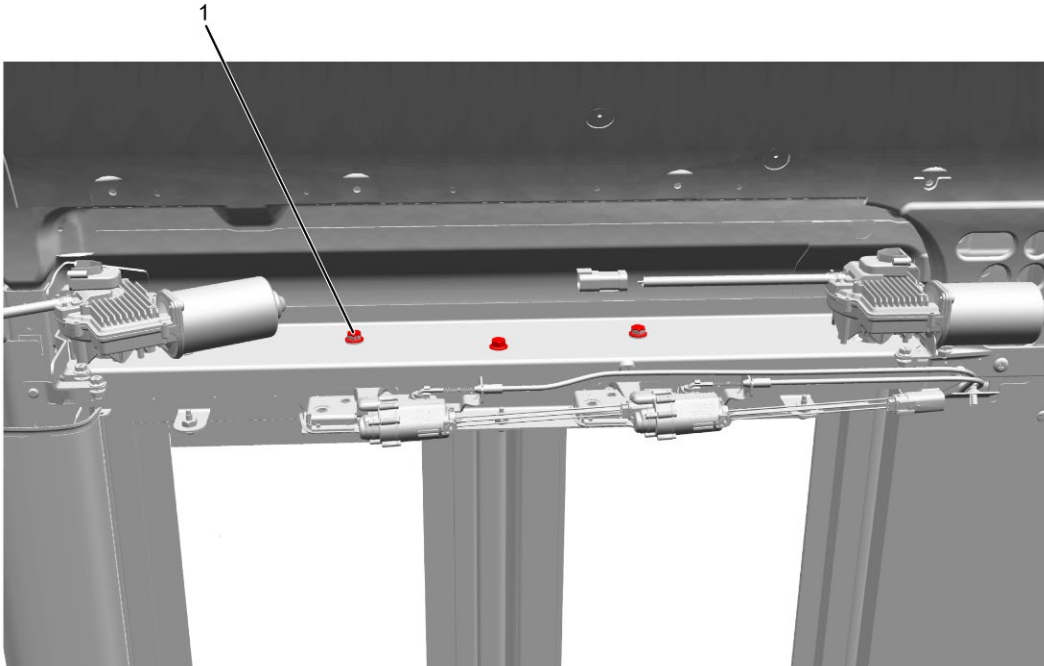

0000480861

Figure 16. Electric Entrance Door Mounting Plate Bolts

1. M8 x 16 mounting plate bolt (3)

34. Remove three M8 x 16 mounting plate bolts (Figure 16, Item 1) from the mounting support and remove the assembly.

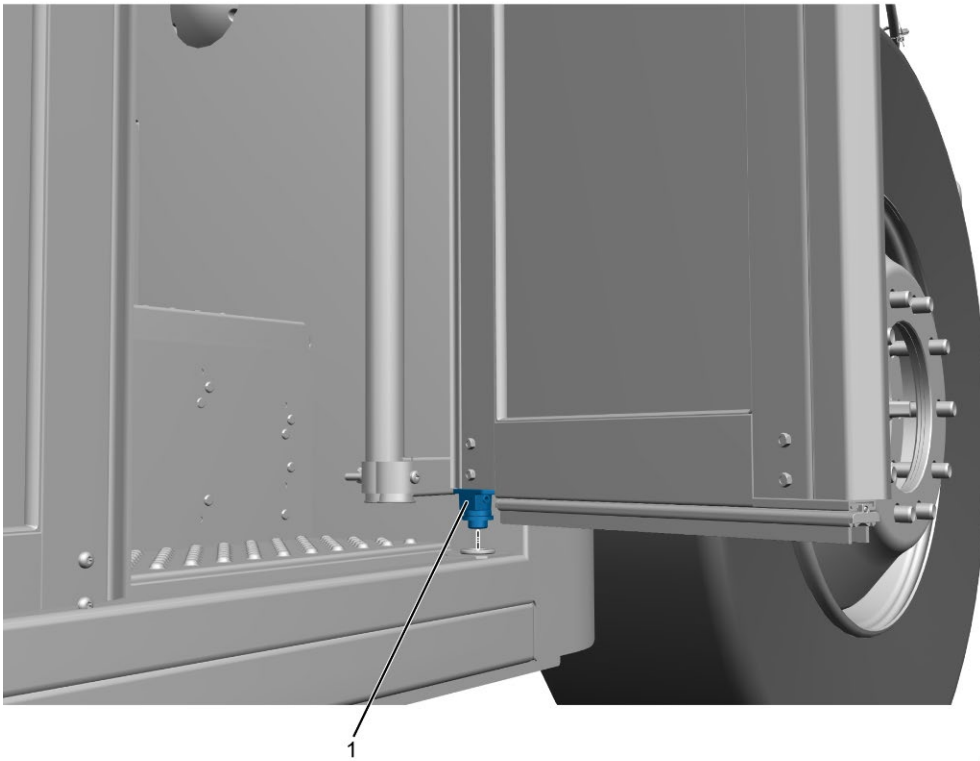

0000490373

Figure 17. Entrance Door Lower Male Hinge

1. Lower male hinge

35. With entrance door in an open position, gently lift entrance door up to release lower male hinge (Figure 17, Item 1).

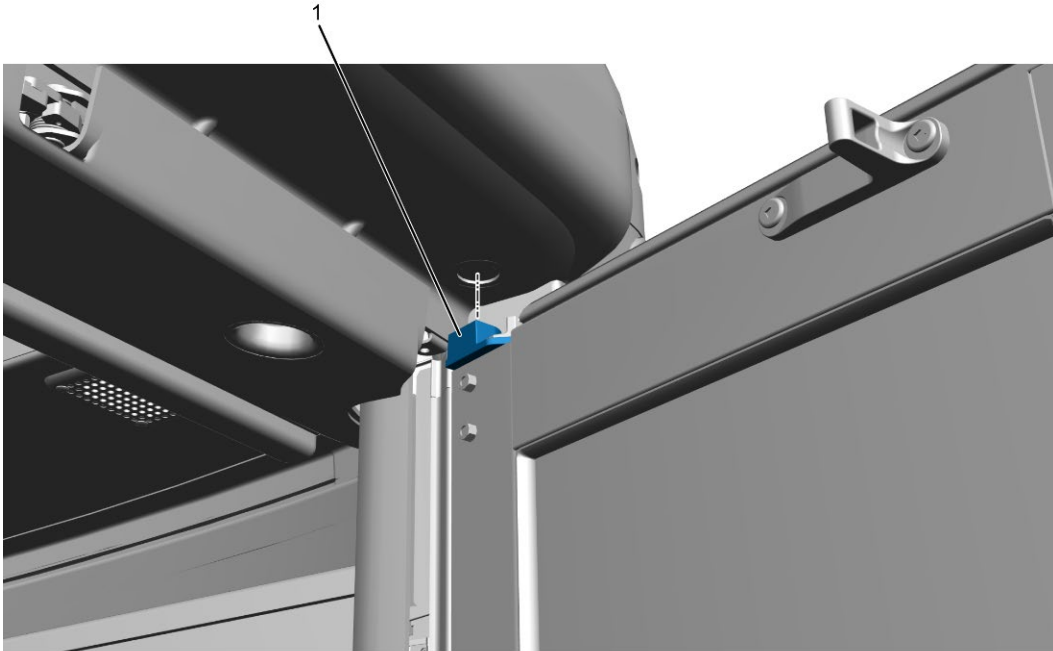

0000490379

Figure 18. Entrance Door Upper Female Hinge

1. Upper female hinge

36. Gently tilt and lower door out of frame to release the upper female hinge (Figure 18, Item 1).
37. Place door flat on a protected surface.

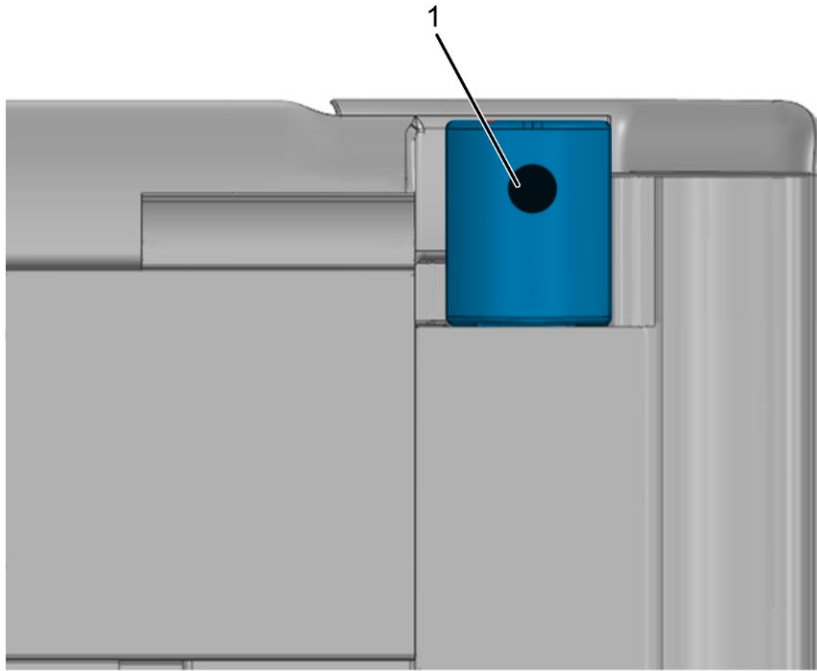

0000494479

Figure 19. Set Screw Location

1. Set screw hole

38. Drill a new hole where the set screw was (Figure 19, Item 1), ensuring it is straight as possible. The new hole should have a 0.272 in diameter.
39. Tap the new hole with a 5/16 in-24 tap. Deburr and remove any metal shavings.
40. Partially insert the new 5/16 in-24 set screws into the new threaded hole.
41. Repeat Steps 35–40 for the other door leaf.

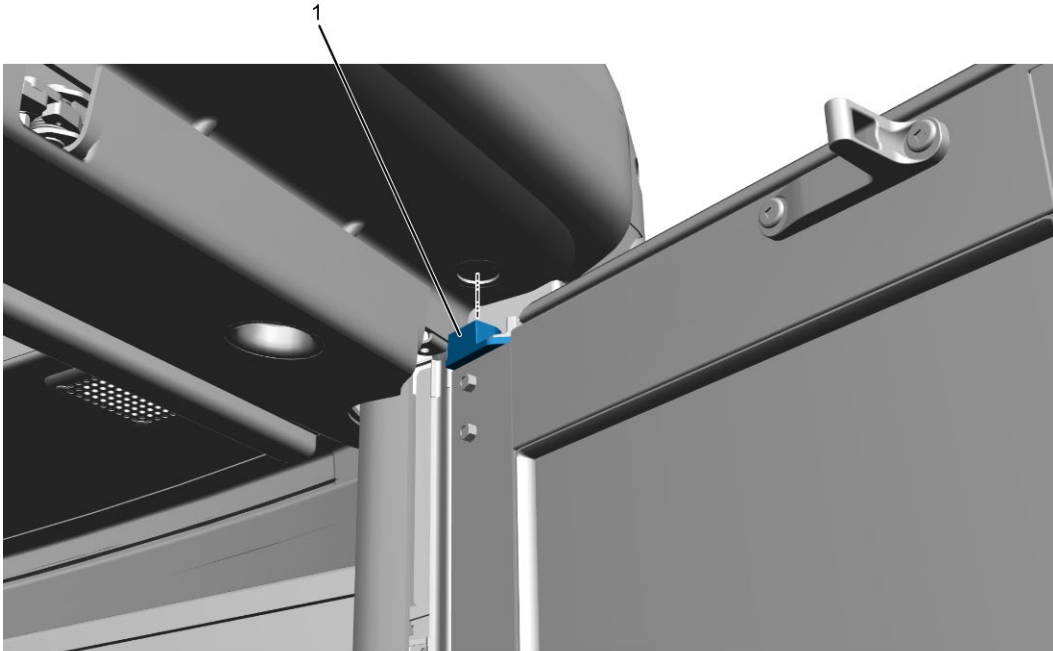

0000490379

Figure 20. Entrance Door Upper Female Hinge

1. Upper female hinge

42. Gently tilt and raise door into frame, ensuring that upper female hinge (Figure 20, Item 1) slides into place.

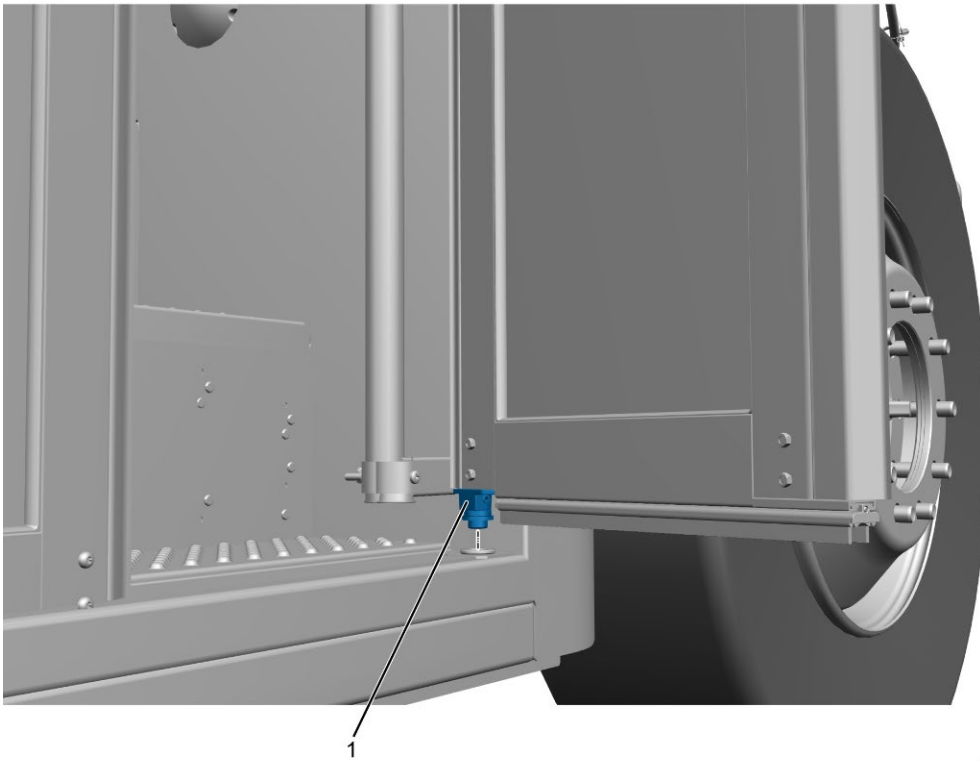

0000490373

Figure 21. Entrance Door Lower Male Hinge

1. Lower male hinge

43. With entrance door in an open position, gently lift entrance door up to insert lower male hinge (Figure 21, Item 1).

44. Repeat Steps 42–43 for the other door leaf.

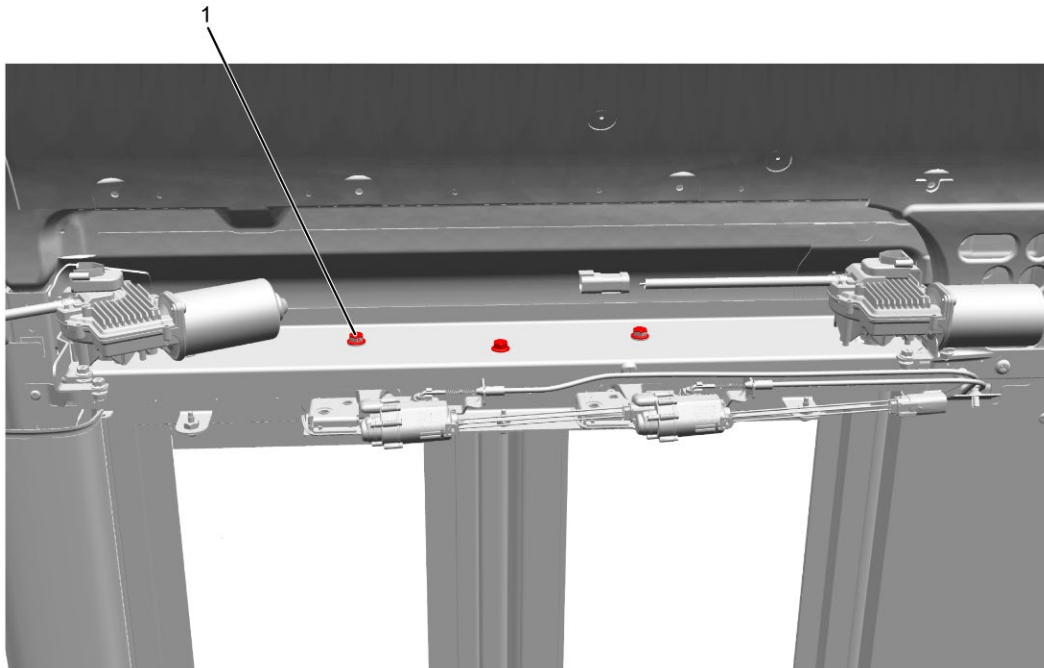
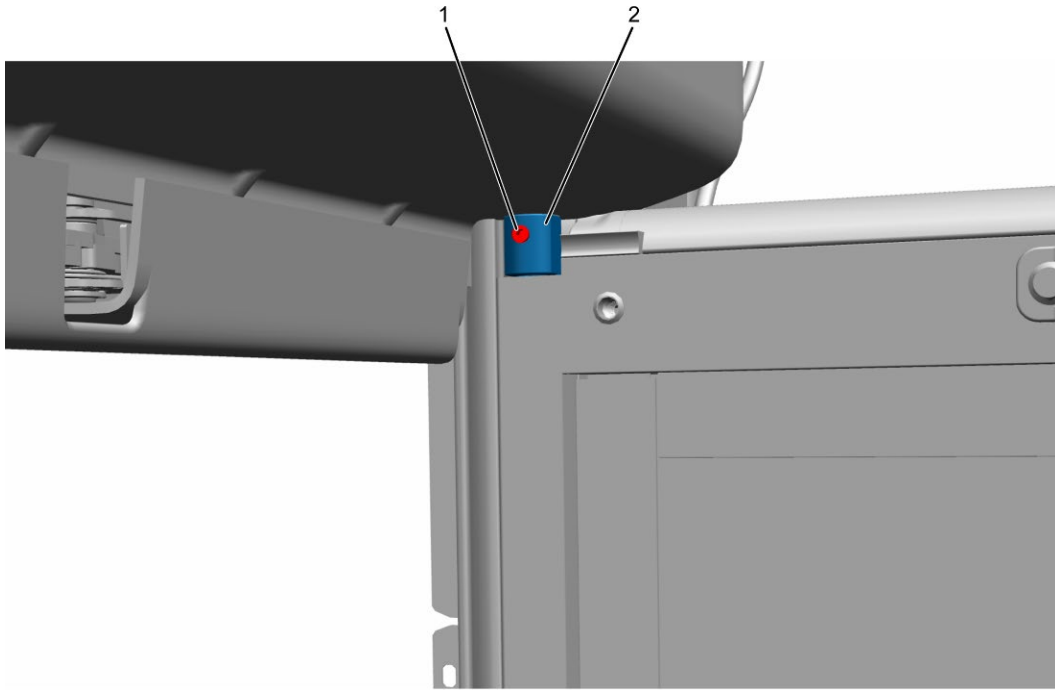

Figure 22. Electric Entrance Door Mounting Plate Bolts

1. M8 x 16 mounting plate bolt (3)

45. With entrance door electric motors secured to mounting plate, place electric motor assembly with mounting plate above door frame, ensuring that the door pivots are seated within door collar.
46. Secure mounting plate above entrance door with three M8 x 16 bolts (Figure 22, Item 1).
47. Tighten M8 x 16 bolts to 23–26 lb-ft (31–35 N·m).



0000481034

Figure 23. Entrance Door Collar

1. Set screw
2. Door collar

48. Tighten set screw (Figure 23, Item 1) located on door collar (Figure 23, Item 2) to 200 lb-in (22.6 N·m). Repeat for both entrance doors.

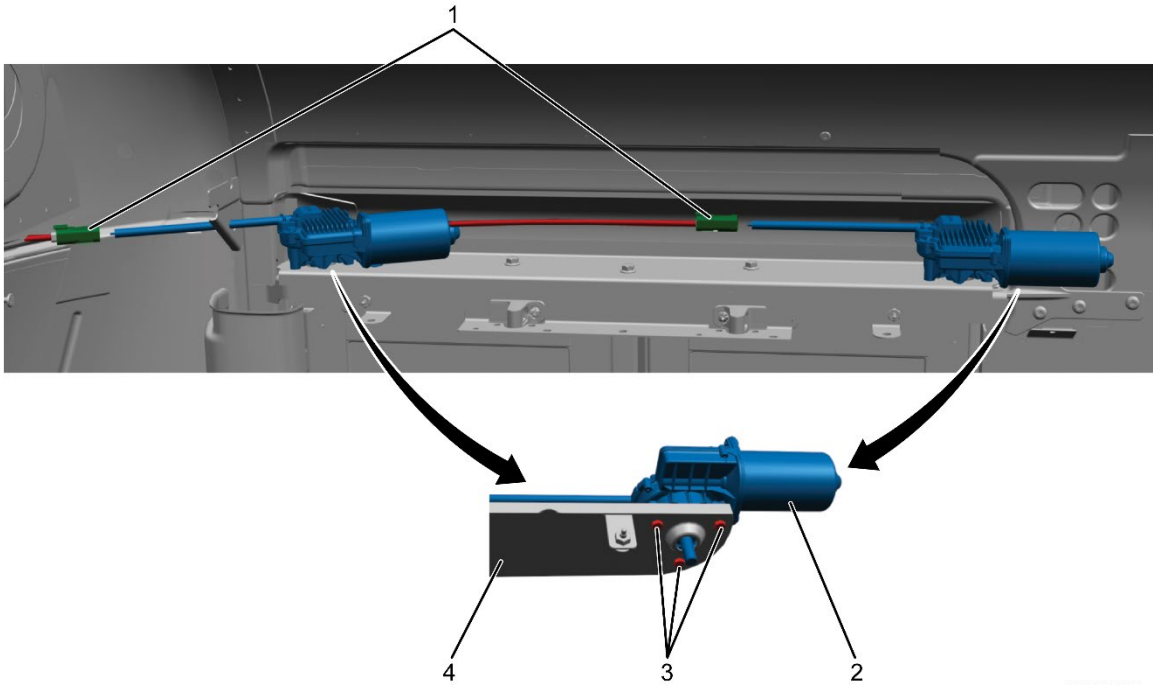

0000477201

Figure 24. Entrance Door Electric Motor

1. Electric motor connector (2)
2. Entrance door electric motor (2)
3. M6 x 20 hex bolt (6, 3 shown)
4. Mounting support plate

49. Connect two electric motor connectors (Figure 24, Item 1) to entrance door electric motors (Figure 24, Item 2), install cable ties as necessary.

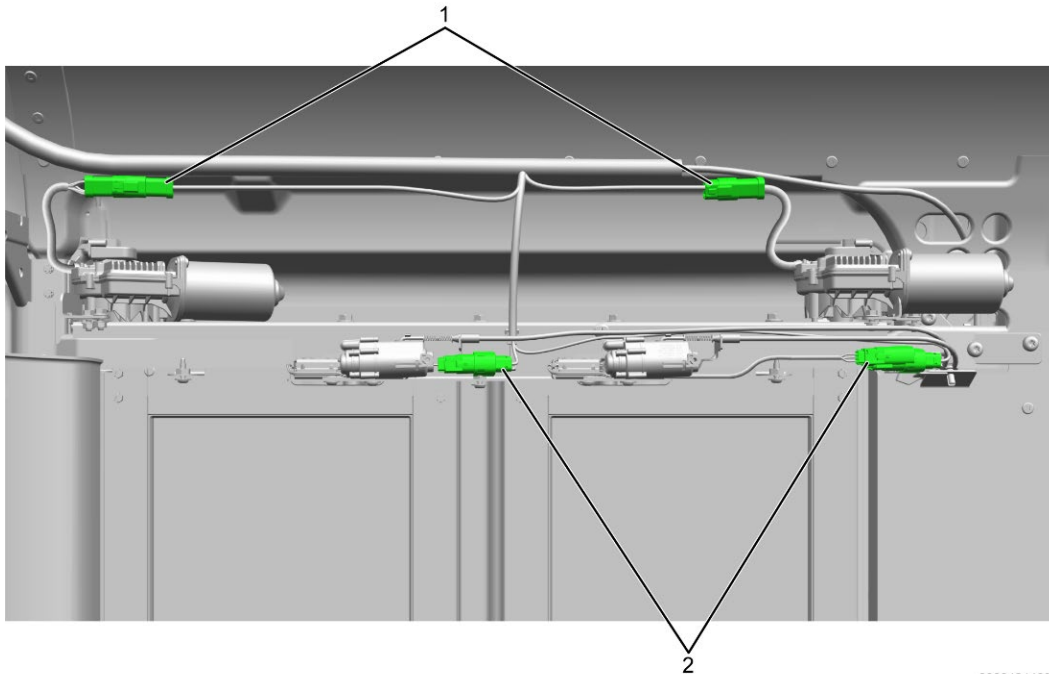

0000484463

Figure 25. Electric Door Motor Electric Connections

1. Electric motor connector (2)
2. Door latch connector (2)

50. Ensuring the connectors match the actuator (FWD or AFT), connect the two door latch connectors (Figure 25, Item 2).

51. Install new battery negative terminal nut.

STRIKER ALIGNMENT PROCEDURE

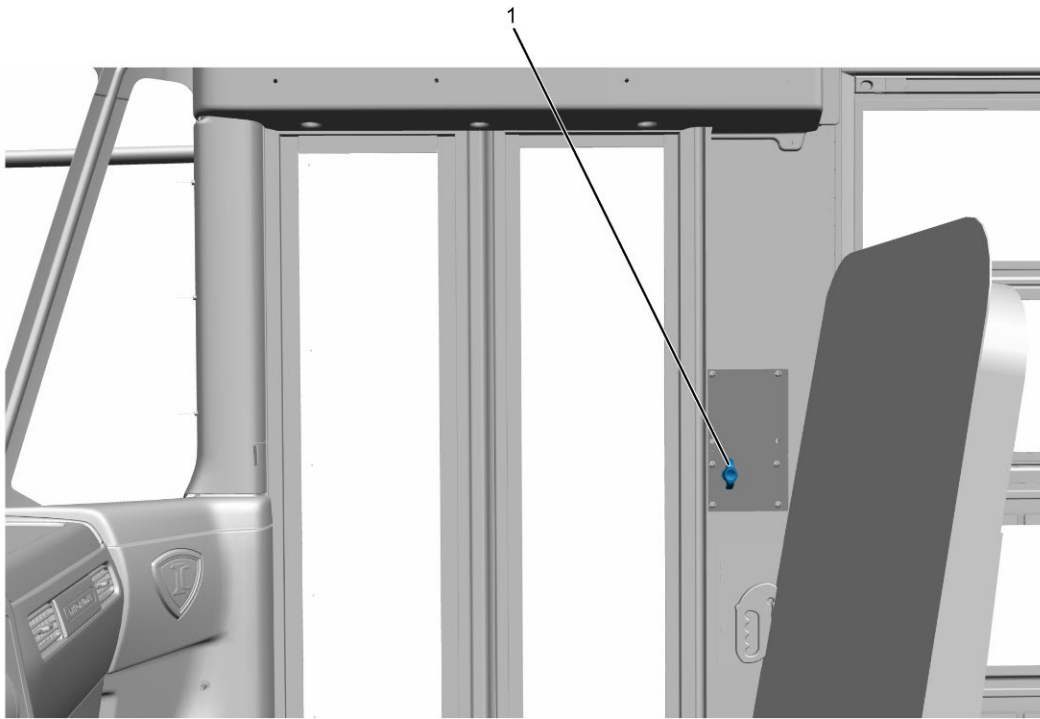

0000484859

Figure 26. Manual Door Release

1. Manual door release

52. If the doors are not already in the open position, with Key ON, Engine OFF, turn manual door release (Figure 26, Item 1) to manual position and gently push open entrance doors.

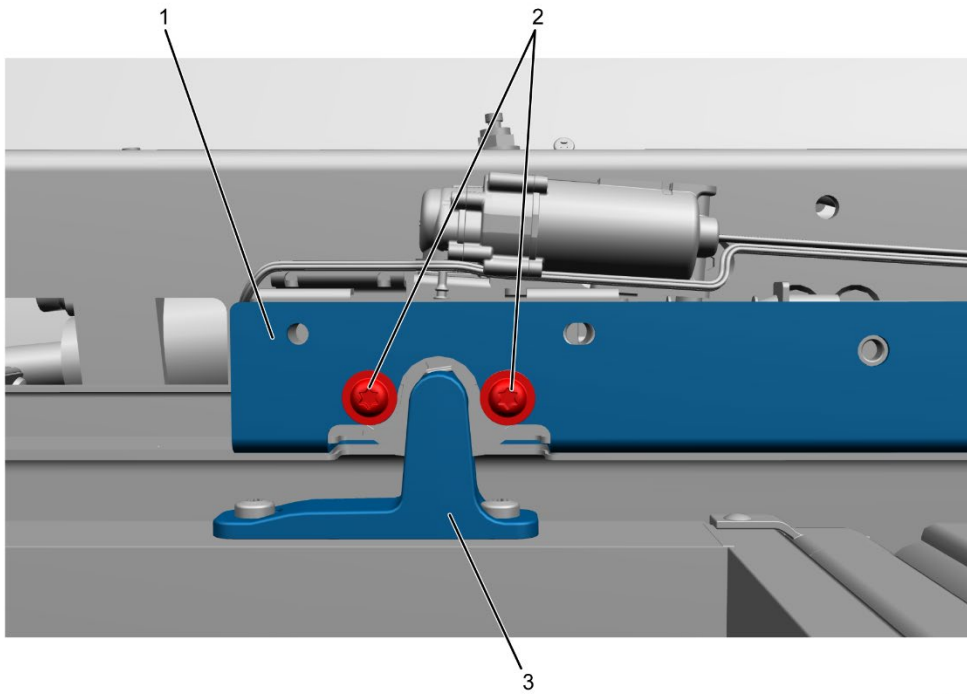

0000484206

Figure 27. Latch Bolts

1. Latch
2. M6 x 20 mm Torx bolt (2)
3. Entrance door striker

53. Loosen two M6 x 20 mm Torx bolts (Figure 27, Item 2).

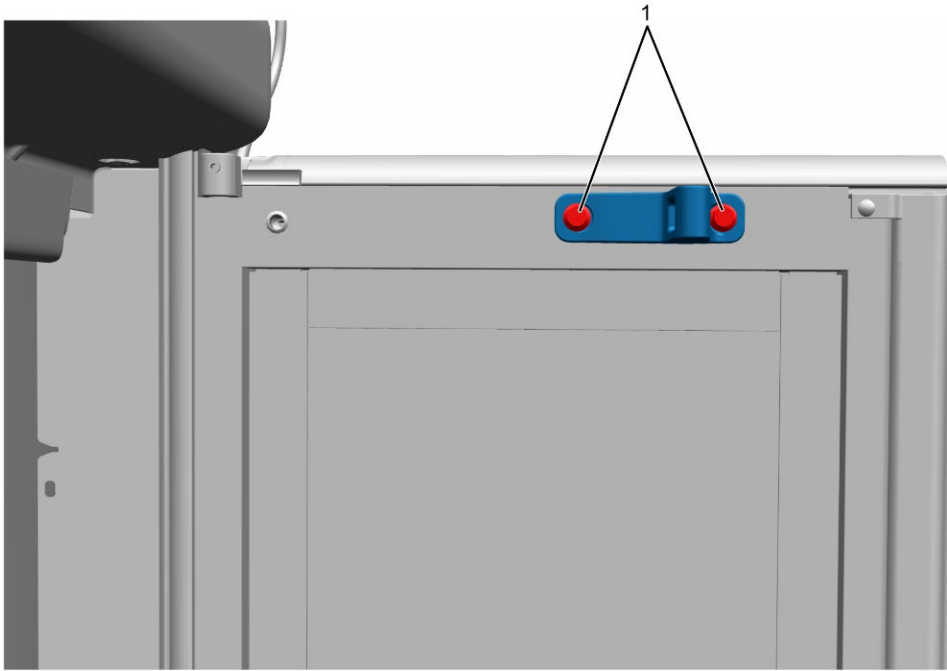

0000484209

Figure 28. Entrance Door Striker Bolts

1. M6 x 20 mm Torx bolt (2)

54. Loosen two M6 x 20 mm Torx bolts (Figure 28, Item 1).
55. Turn manual release to active position and close aft entrance door, and check entrance door striker and latch for proper alignment. The entrance door will make two audible clicks when closed and latched properly.

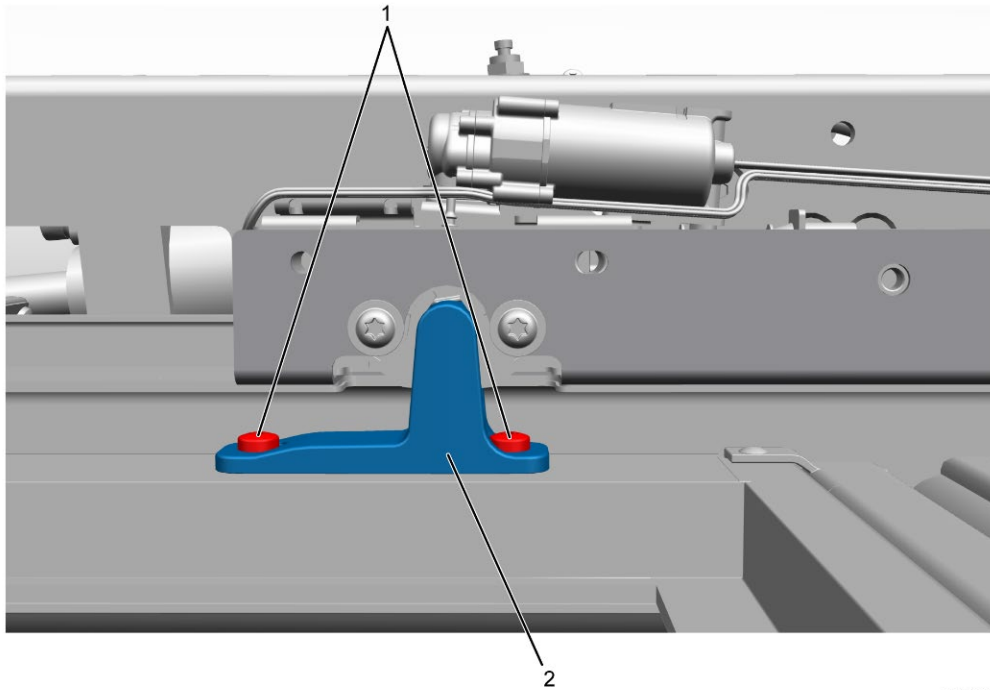

0000484208

Figure 29. Entrance Door Striker

- 1. M6 x 20 mm Torx bolt (2)
- 2. Entrance door striker

- 56. Once determined that entrance door striker is in the correct position, hand tighten two M6 x 20 mm Torx bolts (Figure 28, Item 1) on entrance door striker (Figure 29, Item 2).
- 57. Turn manual release to manual position and gently push open aft entrance door.

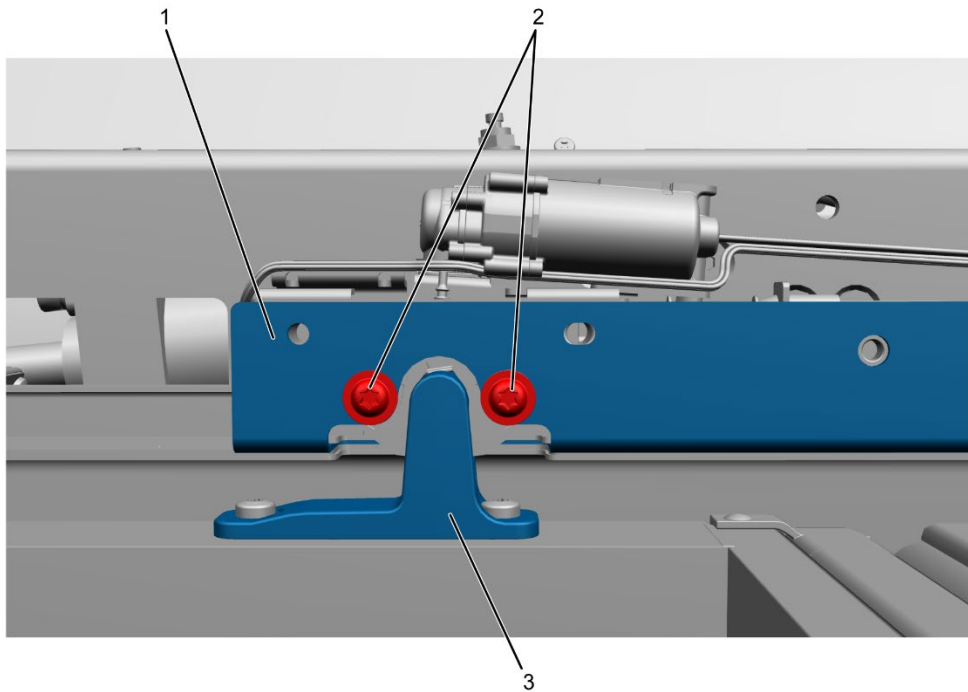

0000484206

Figure 30. Latch Bolts

1. Latch
2. M6 x 20 mm Torx bolt (2)
3. Entrance door striker

58. Tighten two M6 x 20 mm Torx bolts (Figure 30, Item 2) to 4.4 – 5.9 lb-ft (6 – 8 N·m).

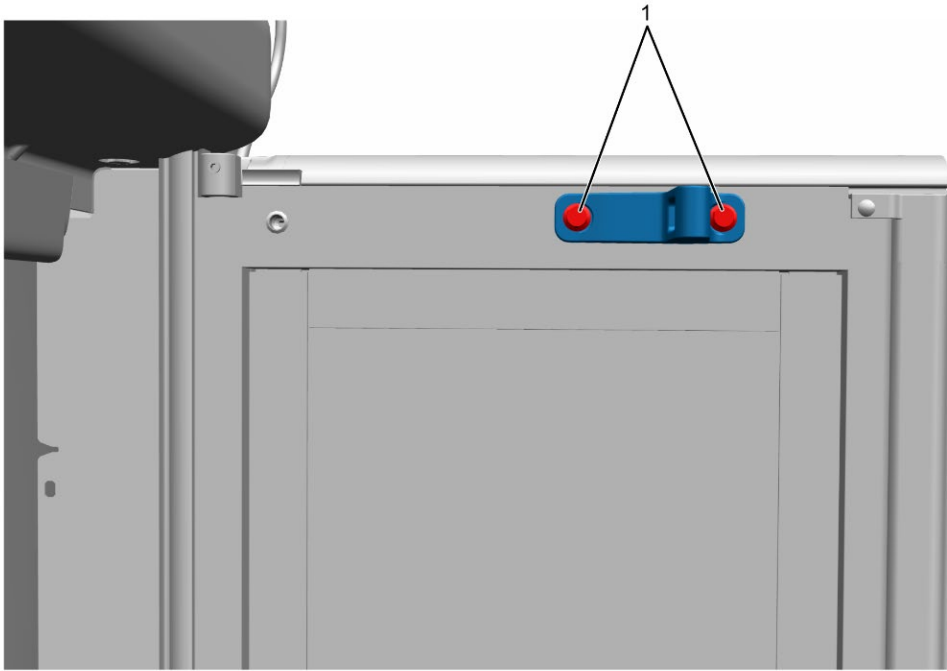

0000484209

Figure 31. Striker Bolts

1. M6 x 20 mm bolt (2)

59. With entrance door open, tighten two M6 x 20 mm striker bolts (Figure 31, Item 1) to 7.1–7.9 lb-ft (9.7–10.7 N·m).
60. Turn manual release to active position and close aft entrance door.
61. Repeat Steps 53–60 for forward entrance door if required.
62. Once entrance door striker has been properly aligned, open and close entrance doors to check alignment, listen for two audible clicks for each entrance door, and check alignment.

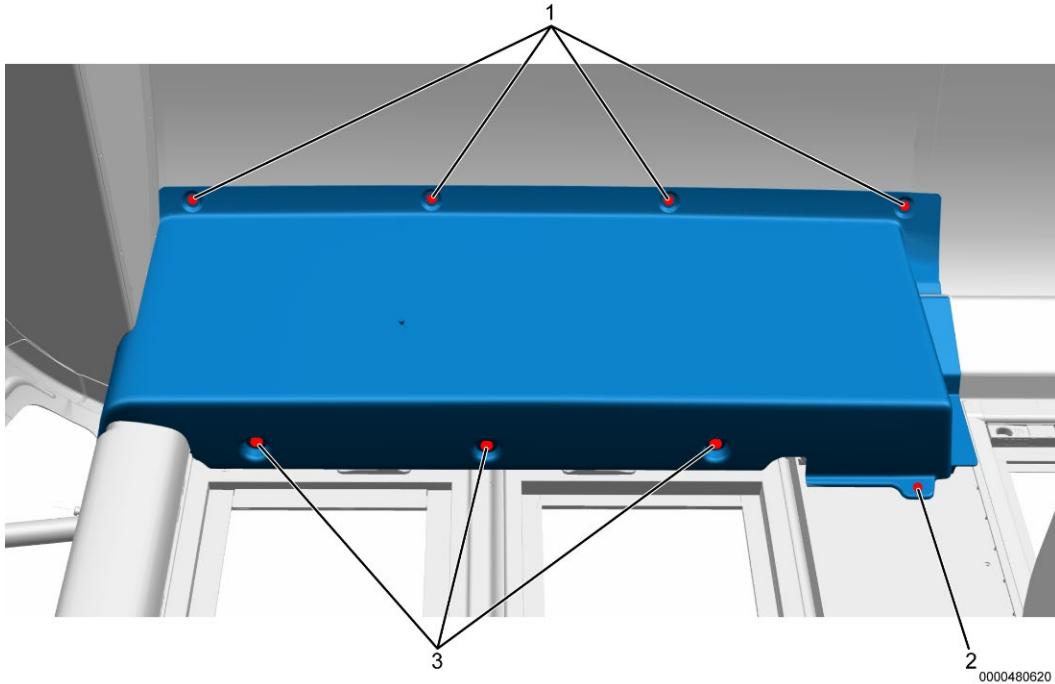

Figure 32. Entry Door Overhead Compartment

1. 8 mm push-in fastener (4)
2. M6 x 20 mm flanged Torx screw (3)
3. 12–14 x .75 mm pan head Torx screw

63. Install overhead panel with four 8 mm push-in fasteners (Figure 32, Item 1) in entry door overhead compartment.
64. Secure three M6 x 20 mm flanged Torx screws (Figure 32, Item 2) and one 12–14 x .75 mm pan head Torx screw (Figure 32, Item 3) in entry door overhead compartment and hand tighten.
65. Remove wheel chocks.

END OF SERVICE PROCEDURE

LABOR INFORMATION

Operation Number	Description	Time
A40-26104-1	Drill and install new set screw	0.8 hrs

Table 3 Labor Information

WARRANTY CLAIMS

Warranty claim expense is to be charged to Warranty. Claims are to be submitted in the normal manner, making reference to Field Service Campaign 26104.

Section 7 of the Warranty Policy and Procedures Manual contains further information related to the submission and processing of AFC / Recall claims.

As with all claim submissions, items acquired locally must be submitted in the “Other Charges” tab. The cost of any bulk items (such as a bag of cable tie straps, roll of wire, barrel of oil, or tube of silicone) should be prorated for the cost of the individual pieces / amount used during each repair.

To make sure this important improvement is made in a timely manner, all claims for 26104 activity must be submitted by 04 20 2027 or within the normal warranty period for the component, if after 04 20 2027.

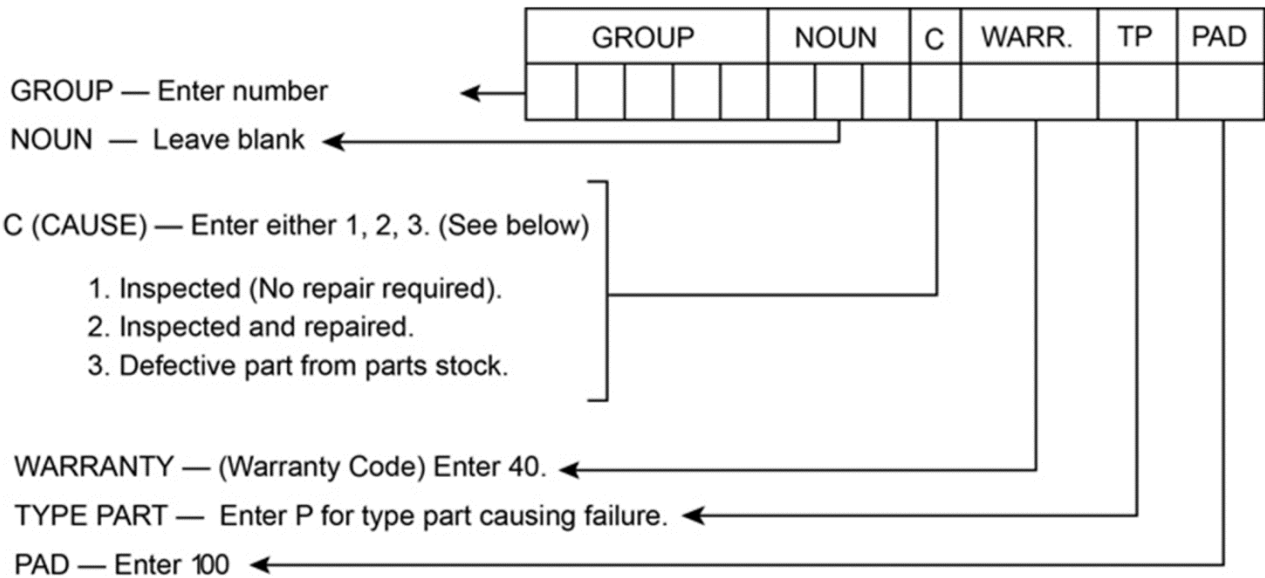

0000047910