Item: TB262.1
Description: Valve Clearance Shim Range
Model Affected: Street Triple 765 RX, Street Triple R, Street Triple RS, Street Triple Moto2™ Edition, Tiger Sport 800 Tour, Trident 800

We would like to inform dealers that the valve shim range for the models listed above has changed.

The original condition shim range was 1.7 mm to 3.0 mm.

The new condition shim range is 2.075 mm to 3.0 mm.

The shim part numbers listed in the table below must only be used with the new valve spring retainer, part number 1131111.

Part number	Shim
1130540	1.700 mm
1130542	1.725 mm
1130544	1.750 mm
1130546	1.775 mm
1130548	1.800 mm
1130550	1.825 mm
1130552	1.850 mm
1130554	1.875 mm
1130556	1.900 mm
1130558	1.925 mm
1130560	1.950 mm
1130562	1.975 mm
1130564	2.000 mm
1130566	2.025 mm
1130568	2.050 mm

When carrying out the valve clearance adjustment and the shims listed above are required for correct valve clearance, check to see if the original condition valve spring retainer is fitted (part number 1131090), or the latest condition valve spring retainer is fitted (part number 1131111).

See the image below showing the original and latest condition valve spring retainers.

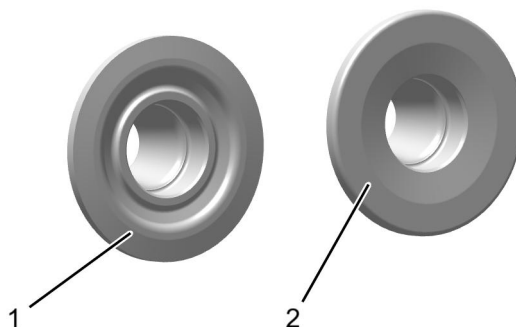

1. Original condition valve spring retainer (part number 1131090)
2. Latest condition valve spring retainer (part number 1131111)

If the original condition valve spring retainer is fitted (part number 1131090), it must be replaced with the new condition spring retainer (part number 1131111) before using the shims listed in the table above.
If one original condition valve spring retainer is to be replaced, replace all valve spring retainer and shims.
If the valve clearance can not be achieved, contact Triumph Motorcycles Limited.