

Preview Solution CBR-2540-7

Upper Bunk Restraint System – Plastic Gable Retention Field Fix

Published 13 April 2026

Valid For

Mack Chassis - AN (4), PR

Volvo Chassis - VN (4)

Model Year - 2025 to current

Tools Required

- Torx T25 bit
- Drill and drill bits (max 1/8 in)
- Hole starter punch
- Measuring device
- Masking tape

Parts Required

Parts Required		
969278	Six-point socket screw ST 4.8 × 13	6 screws per bunk restraint



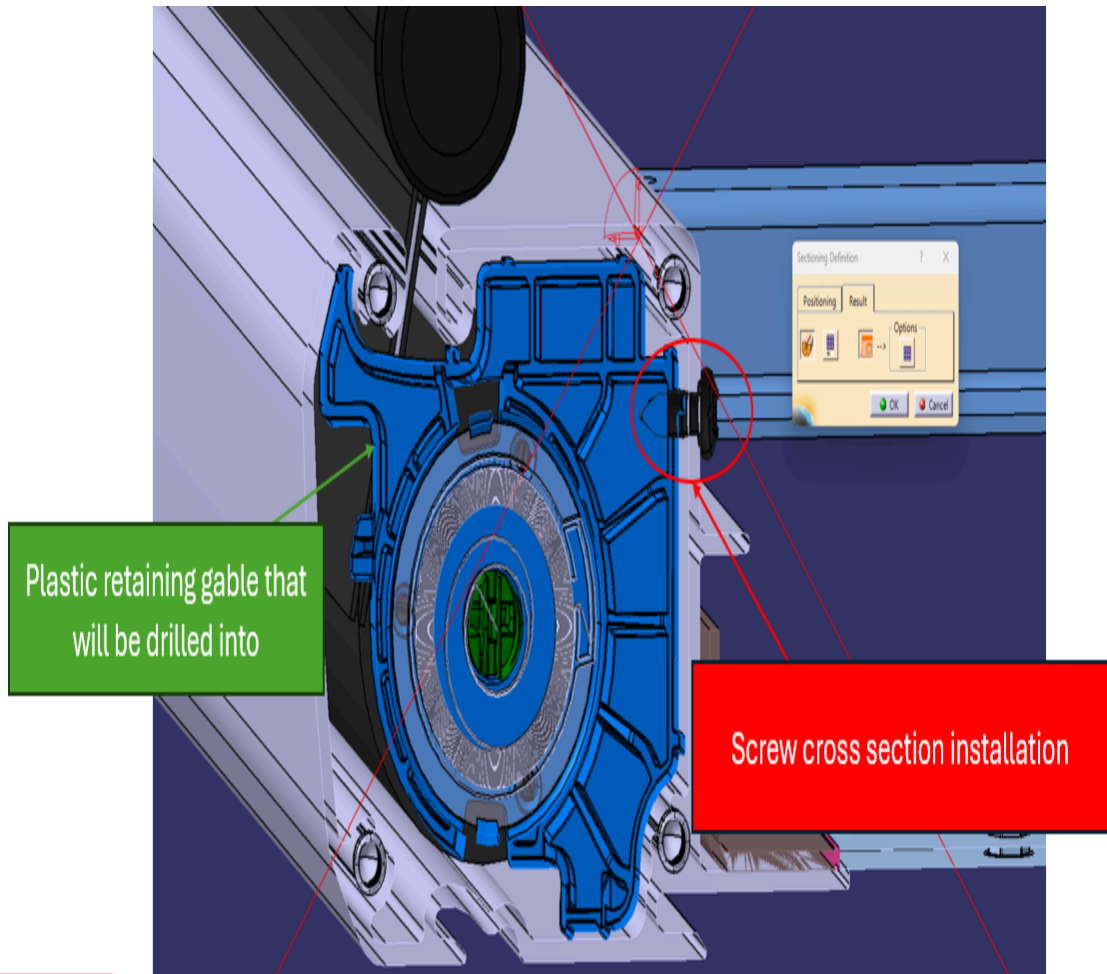
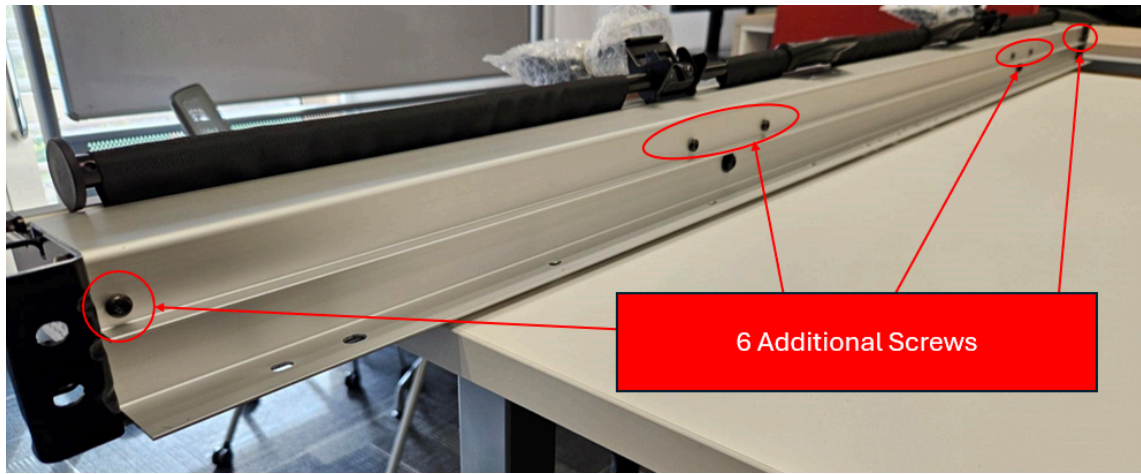

Preparation

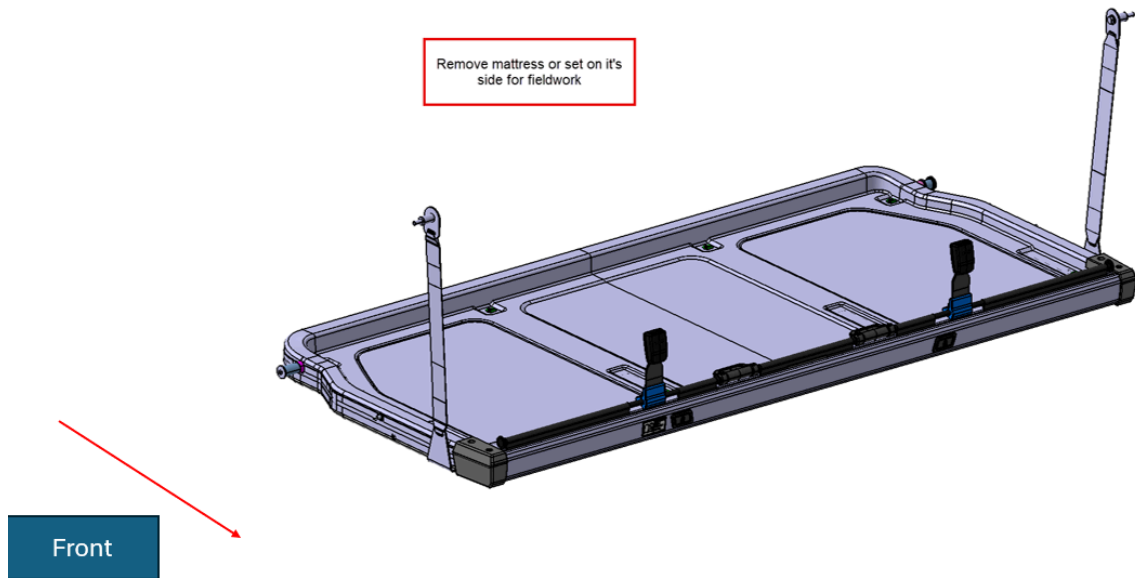

- Remove or set aside upper bunk mattress.

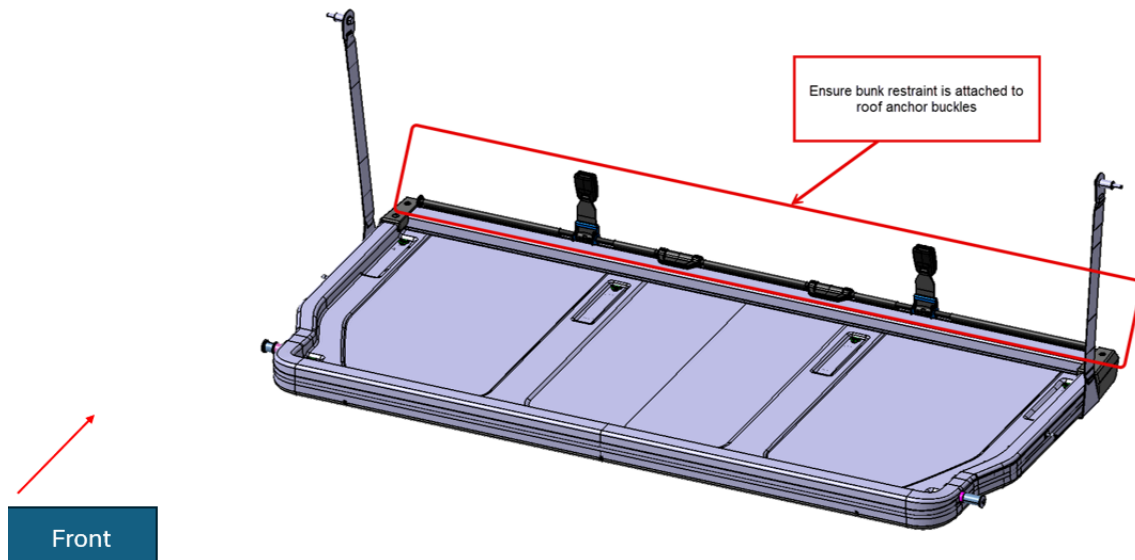

- Plastic gables are visible through the curtain slot opening. Access and visibility are achieved through this opening; removal of additional trim is not required.

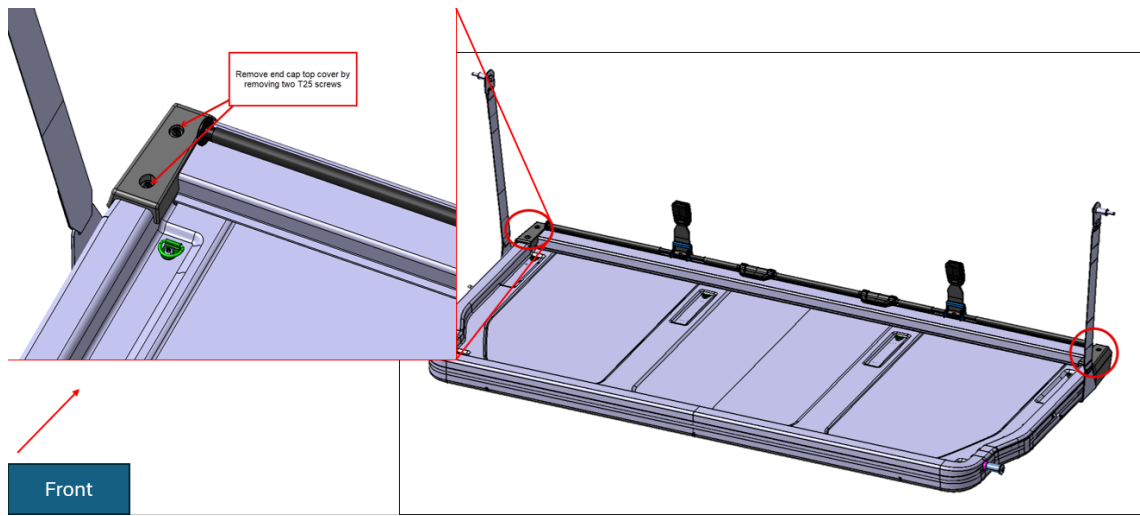

- Remove LH and RH top portions of end caps and retain for reinstallation.

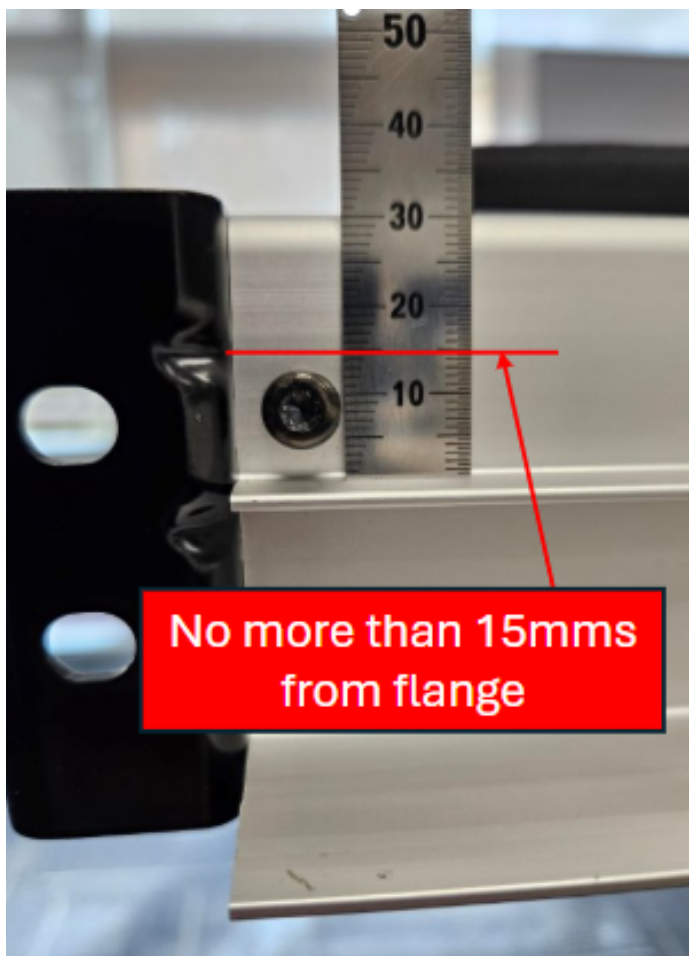

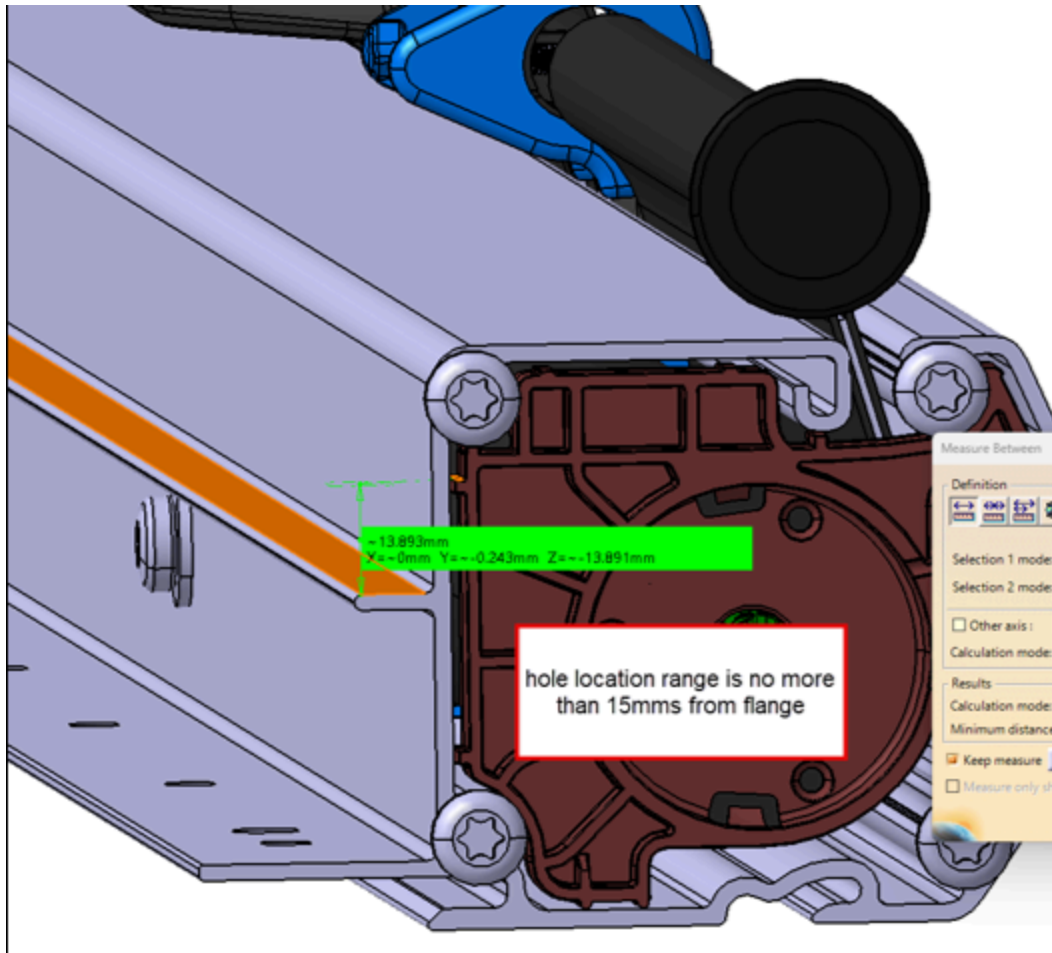

- Mark centerline of each plastic gable using masking tape.
- Measure approximately 15 mm from the back flange of the restraint. Do not exceed this measurement.
- Drill pilot hole if needed (do not exceed 1/8 in bit).
- Work from one end to the opposite end to prevent gable shift.

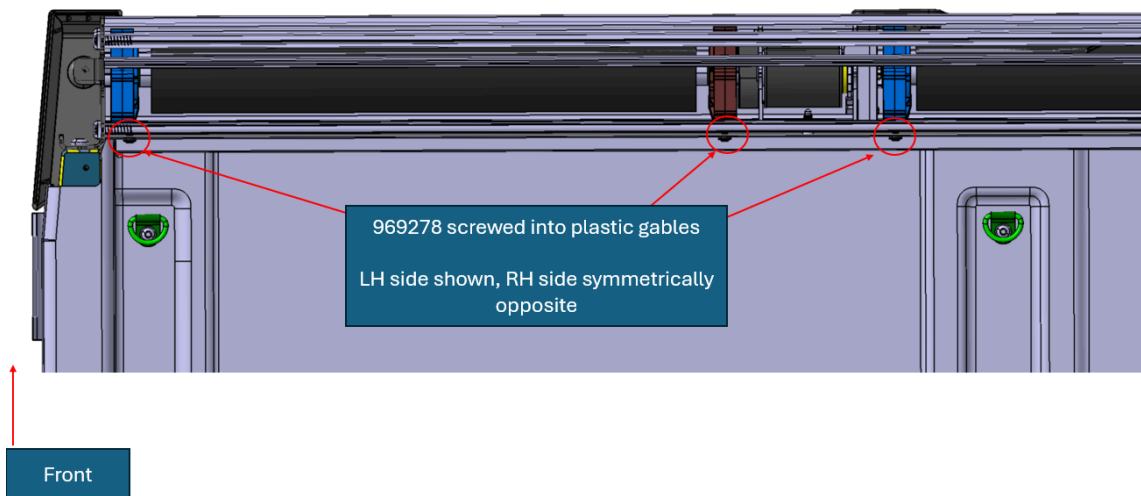

Cross-sectional view indicating the required screw fastening locations.



- Drill through aluminum restraint and plastic gable.
- Maximum drill depth: 0.5 in.
- Install screw 969278 into each plastic gable.
- LH side shown; RH side is symmetrical.



After field fix containment solution 3 out of 6 screws
LH side shown RH Side symmetrically opposite



I webbing does not retract fully down, loosen screw slightly for affected reworked retractor. Loosening the screw will allow the retractor to unbind.



- Reinstall LH and RH end caps.
- Clean up all metal shavings and debris.
- Reinstall mattress if previously removed.

Related links and attachments

No links or attachments available



Share

to others that might find it helpful



Feedback

[Give feedback](#)

to help improve the content of this article