

**Title:** Orbital Package Install (updated)

**Applicability:** MY2025 Revero

**Type:** Technical Bulletin

**Year:** 2025

**System:** Body (70)

**Sequence:** 01 Revision: 3

**PURPOSE:** This document is provided to remedy a condition where the Orbital (formerly the Distinction) Package trim parts will be installed on the new vehicle. All panels and components of the kits will be described here. The rocker panels require drilling of fastener holes which is performed at the factory to install the properly. This document supersedes any and all previous documents relating to the names and locations in workshop manuals, wiring diagrams, training documents, parts catalog, labor operations, etc.

The racer's edge wheels and new center caps can be completed at anytime of this package installation, remember to torque the wheels to 220 Nm (162 ft-lbs) Labor time for this is included in the labor operation below.



Beginning with the Rocker panels. The rocker panel should be lined up with the correct side carbon cover. The left side rocker panel will be used as an example in this bulletin, the right hand side follows is symmetrical.

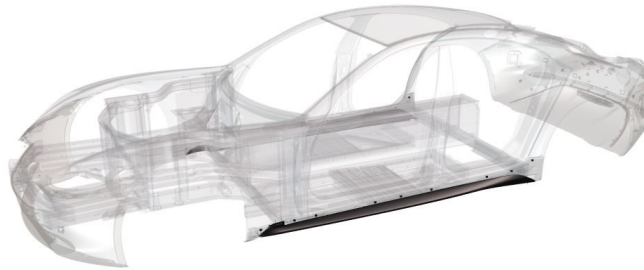

Karma Automotive Bulletins and service documents are intended for use by experienced and trained Technicians. If you lack the skills, tools, equipment and a suitable workshop for any procedure described in this document, we suggest you leave such repairs to a Karma retailer and service provider. See your service provider for advice on whether your vehicle may benefit from the information contained within this document. The information contained in the Karma Bulletin is accurate at the date of publication. However, Karma Automotive regularly updates technical information. Please check with your Karma Automotive Retailer and Karma Automotive service provider that the bulletin you intend to use contains the latest available information.

Title: Orbital Package Install (updated)

Applicability: MY2025 Revero

Line up holes of the respective panels and Rocker Panel Accent - Black LH C231175000700 (and RH C231175000800) to be attached to rocker panel.

Use an alcohol wipe to clean the surface of the Rocker Panel before attaching the panel. The surface must be completely free of grease, dust or any contaminants which may prevent complete adhesion. Not only will the attachment hardware be used but there are adhesive strips in use for attachment. (Fig 1)

Install SCREW-PANHEAD TORX M5 X 0.8 X 16.0 PC8 (C140006003200) to be inserted in 4 locations per side, the left side and right hand rocker panels ( $0.6 \pm 0.1\text{Nm}$ ).

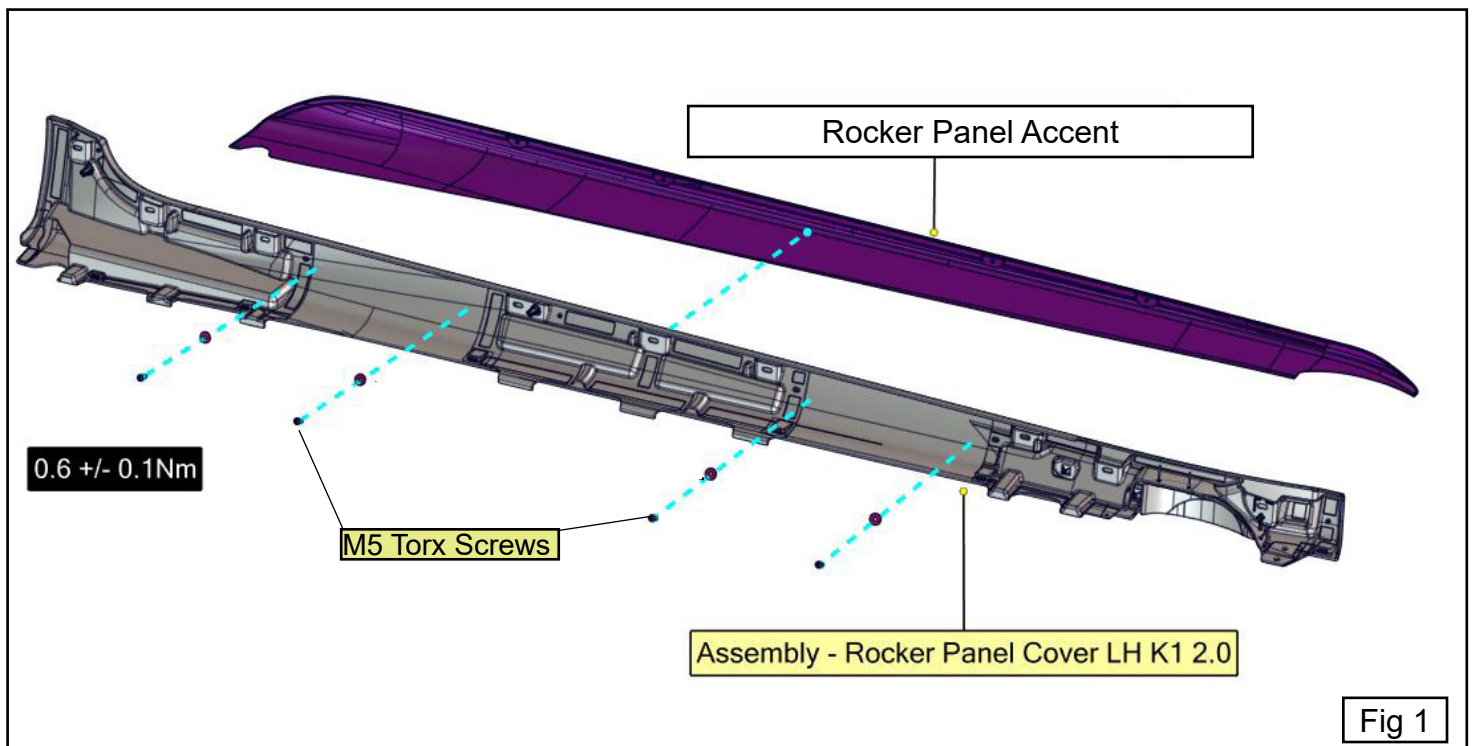

Karma Automotive Bulletins and service documents are intended for use by experienced and trained Technicians. If you lack the skills, tools, equipment and a suitable workshop for any procedure described in this document, we suggest you leave such repairs to a Karma retailer and service provider. See your service provider for advice on whether your vehicle may benefit from the information contained within this document. The information contained in the Karma Bulletin is accurate at the date of publication. However, Karma Automotive regularly updates technical information. Please check with your Karma Automotive Retailer and Karma Automotive service provider that the bulletin you intend to use contains the latest available information.

Title: Orbital Package Install (updated)

Applicability: MY2025 Revero

Use the rocker panel cover as the template for drilling 5 mm diameter holes in to the Rocker panel for pop rivet installation. Use (part number C143600107200 Rivet-pop 3.2 x 4.8) six (6) pop rivets per side to secure the carbon fiber panel to the rocker panel. (fig 2)

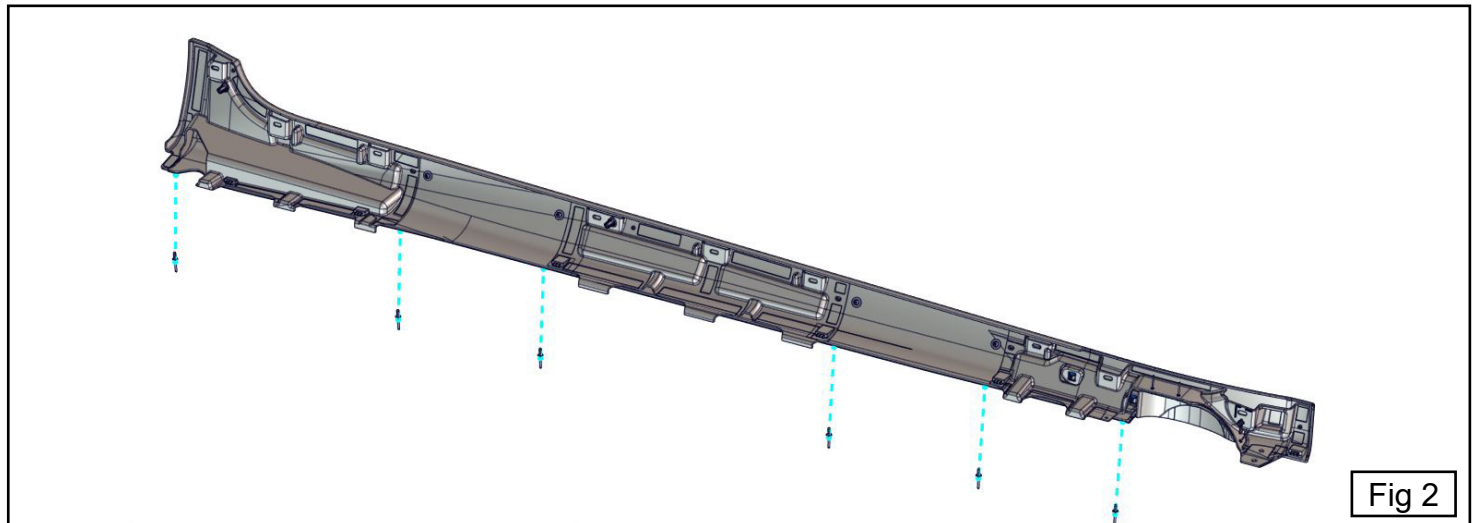

Continue using a drill to add a pilot hole in the center of the opening of the bracket, as shown (Fig 3a). Follow with a through hole of 9.5mm +/- 0.5mm through the bracket, this is the through hole to align the rocker panel carbon accent, LH and RH are symmetrical. The small exhaust cover, is removed and discarded, on application of the carbon rocker panel cover (Fig 3 b).

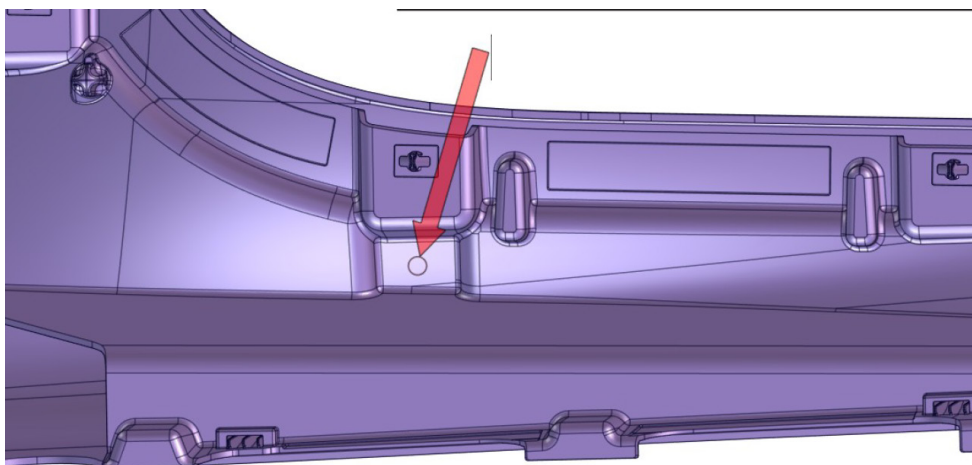

Fig 3a

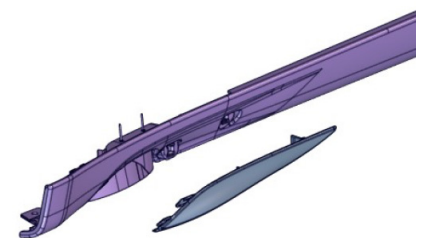

Fig 3b

Karma Automotive Bulletins and service documents are intended for use by experienced and trained Technicians. If you lack the skills, tools, equipment and a suitable workshop for any procedure described in this document, we suggest you leave such repairs to a Karma retailer and service provider. See your service provider for advice on whether your vehicle may benefit from the information contained within this document. The information contained in the Karma Bulletin is accurate at the date of publication. However, Karma Automotive regularly updates technical information. Please check with your Karma Automotive Retailer and Karma Automotive service provider that the bulletin you intend to use contains the latest available information.

**Title:** Orbital Package Install (updated)

**Applicability:** MY2025 Revero

**Type:** Technical Bulletin

**Year:** 2025

**System:** Body (70)

**Sequence:** 01 **Revision:** 3

The rocker cover panel is aligned with the newly drilled hole, and forward stands or guide pins, (Fig 4). The nut is fastened to 7 +/-3Nm.

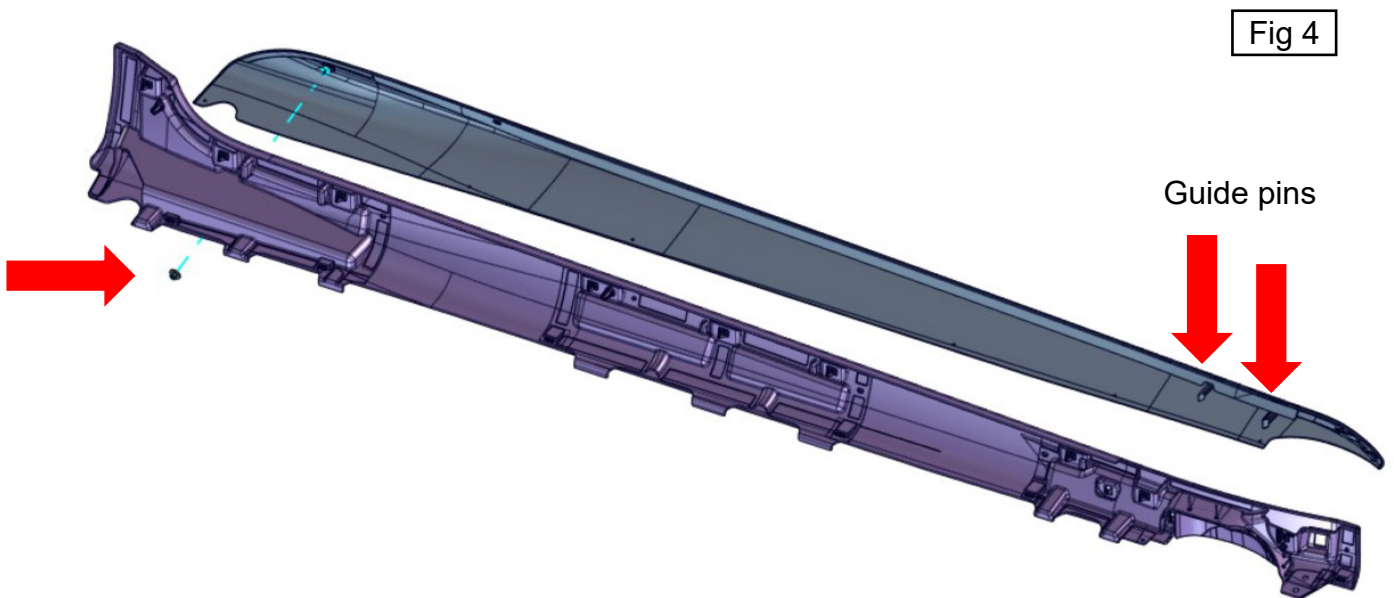

Karma Automotive Bulletins and service documents are intended for use by experienced and trained Technicians. If you lack the skills, tools, equipment and a suitable workshop for any procedure described in this document, we suggest you leave such repairs to a Karma retailer and service provider. See your service provider for advice on whether your vehicle may benefit from the information contained within this document. The information contained in the Karma Bulletin is accurate at the date of publication. However, Karma Automotive regularly updates technical information. Please check with your Karma Automotive Retailer and Karma Automotive service provider that the bulletin you intend to use contains the latest available information.

Title: Orbital Package Install (updated)

Applicability: MY2025 Revero

The 8 fastener clips, marked "A" below, C145010100000 (Clip Quarter Turn w Base 9.0) can now be installed on the panel along the length. The front clip C145000300000 (Clip- Quarter Turn w Base 9.0 Mod) is ahead of the exhaust shroud (marked "B" below). (Fig 4)

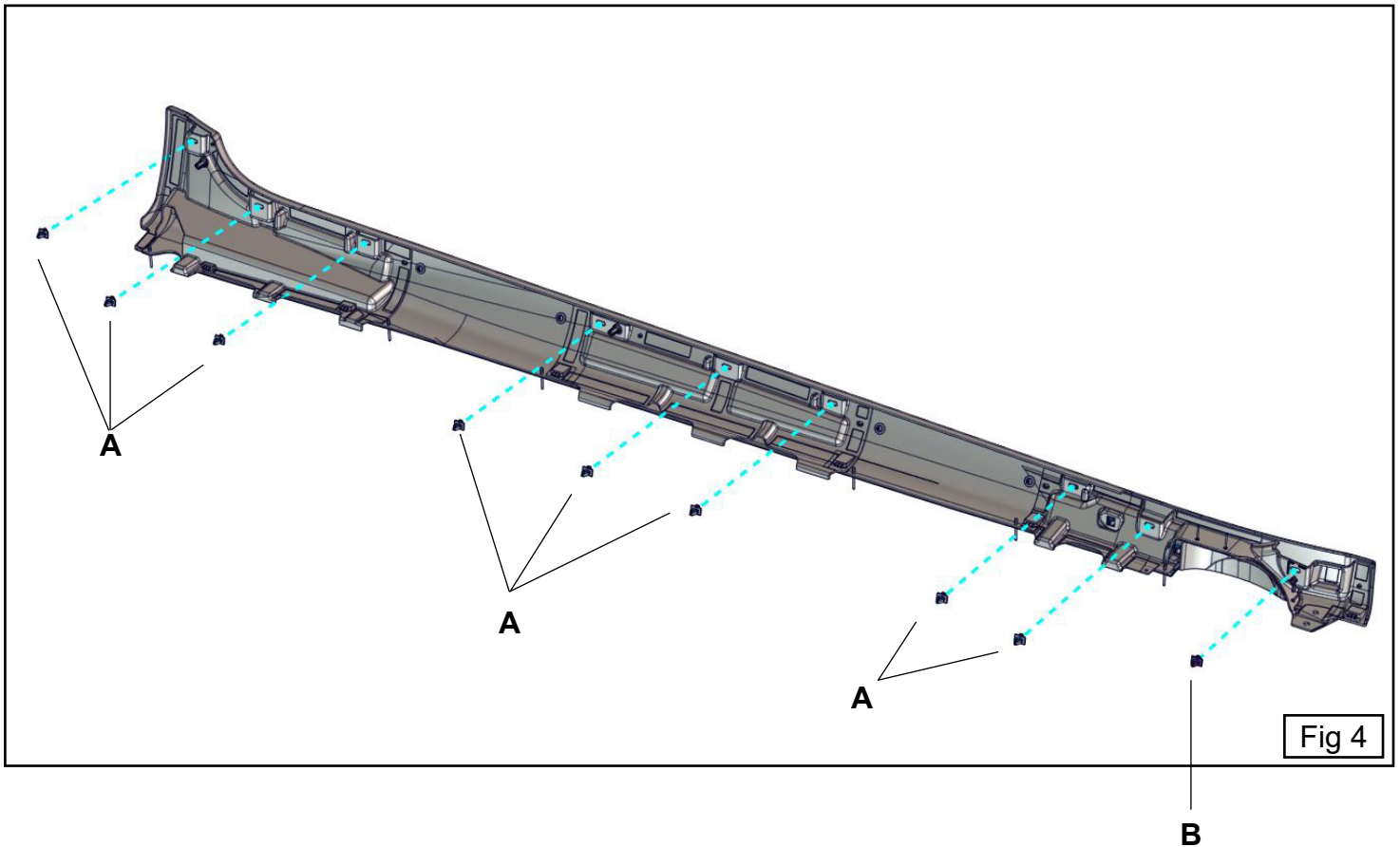

Karma Automotive Bulletins and service documents are intended for use by experienced and trained Technicians. If you lack the skills, tools, equipment and a suitable workshop for any procedure described in this document, we suggest you leave such repairs to a Karma retailer and service provider. See your service provider for advice on whether your vehicle may benefit from the information contained within this document. The information contained in the Karma Bulletin is accurate at the date of publication. However, Karma Automotive regularly updates technical information. Please check with your Karma Automotive Retailer and Karma Automotive service provider that the bulletin you intend to use contains the latest available information.

**Title:** Orbital Package Install (updated)

**Applicability:** MY2025 Revero

**Type:** Technical Bulletin

**Year:** 2025

**System:** Body (70)

**Sequence:** 01 **Revision:** 3

The Rocker Panel assembly with accent panel can now be installed onto the vehicle body, aligning the clips to the respective mount locations. Apply firm pressure to snap this assembly in place. (Fig 5)

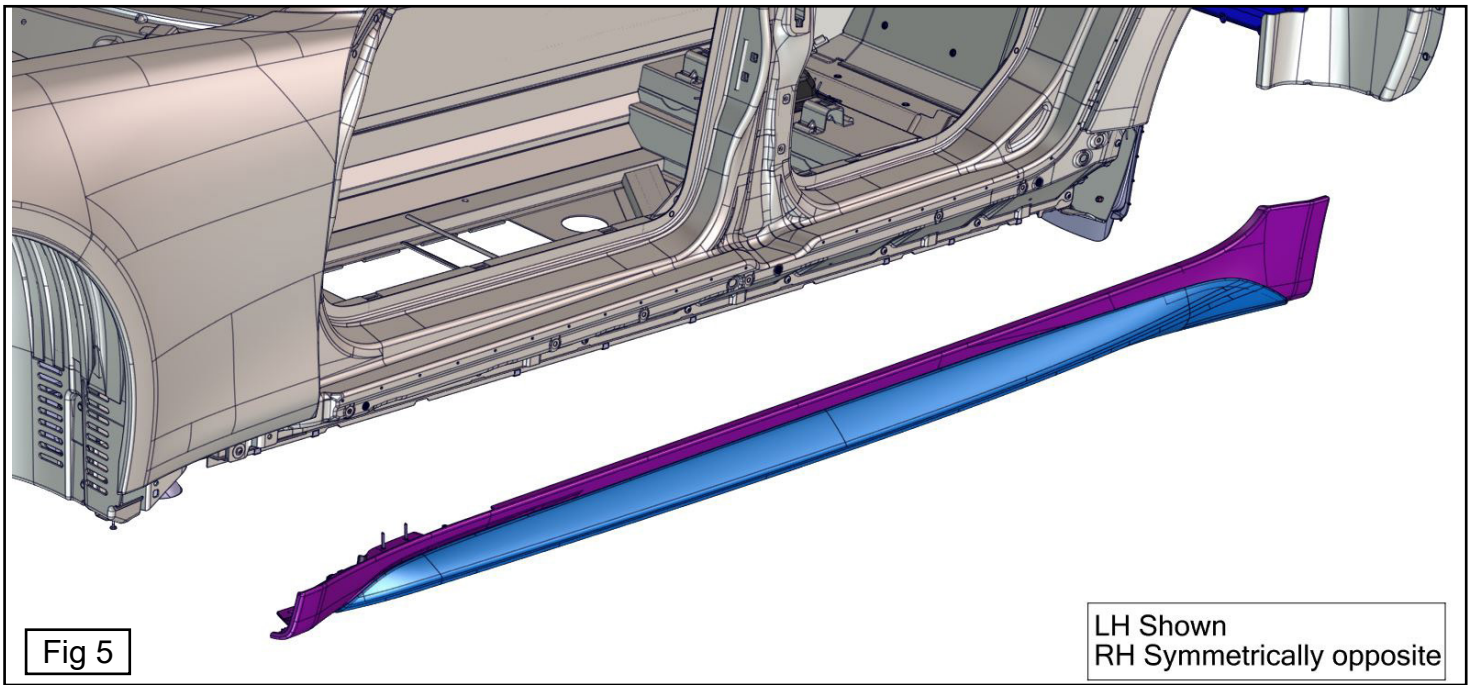

Karma Automotive Bulletins and service documents are intended for use by experienced and trained Technicians. If you lack the skills, tools, equipment and a suitable workshop for any procedure described in this document, we suggest you leave such repairs to a Karma retailer and service provider. See your service provider for advice on whether your vehicle may benefit from the information contained within this document. The information contained in the Karma Bulletin is accurate at the date of publication. However, Karma Automotive regularly updates technical information. Please check with your Karma Automotive Retailer and Karma Automotive service provider that the bulletin you intend to use contains the latest available information.

Title: Orbital Package Install (updated)

Applicability: MY2025 Revero

The mirror cap can be removed while on the vehicle, removal of the mirror assembly is not necessary. The mirror in this guide was placed on a work bench for clarity.



It may help to move the mirror glass with your hands to open the gap to the housing.



Using a plastic panel tool (Fig. 6) insert into one side of the mirror, and pry one corner or side outwards (Fig 7). This may take some gentle yet controlled force. To aid in removal of the glass frame out walk the tool, or fingers, around the mirror, applying some pressure. Pulling too hard on the outside area of the mirror is more likely result in breaking glass, start from the side closest to the vehicle.



**Title:** Orbital Package Install (updated)

**Applicability:** MY2025 Revero

**Type:** Technical Bulletin

**Year:** 2025

**System:** Body (70)

**Sequence:** 01 Revision: 3

Once the mirror glass is loose, carefully lower it to expose the connectors (Fig 8) and disconnect those from the glass; two connectors on the glass backing and one white connector (Fig 9).

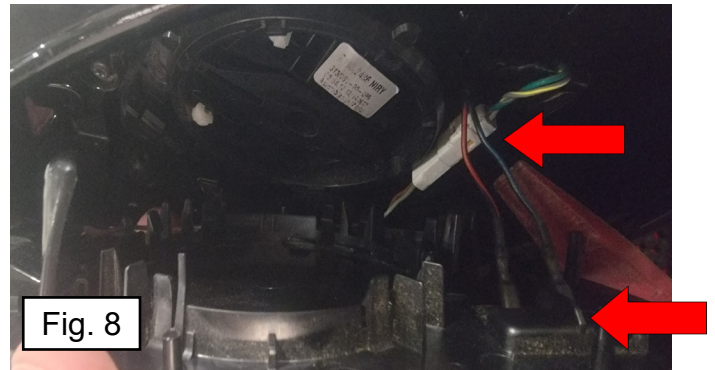

With the mirror glass removed, undo the screws for the surround housing (4, T20 screws reassembly torque is 1.5Nm). This will provide easier access to the scalp clips, to remove and replace.



Karma Automotive Bulletins and service documents are intended for use by experienced and trained Technicians. If you lack the skills, tools, equipment and a suitable workshop for any procedure described in this document, we suggest you leave such repairs to a Karma retailer and service provider. See your service provider for advice on whether your vehicle may benefit from the information contained within this document. The information contained in the Karma Bulletin is accurate at the date of publication. However, Karma Automotive regularly updates technical information. Please check with your Karma Automotive Retailer and Karma Automotive service provider that the bulletin you intend to use contains the latest available information.



Title: Orbital Package Install (updated)

Applicability: MY2025 Revero

Replace the mirror caps with the provided parts (these will be black). begin by removal of the originals caps (sometimes referred to as scalps, or skull caps). Line up the scalp tabs to the mirror sub-assembly snap features. An audible “snap” is heard when both parts are fully engaged. Check the gap consistency to the frame for confirmation of proper installation (fig 12a and fig 12b).

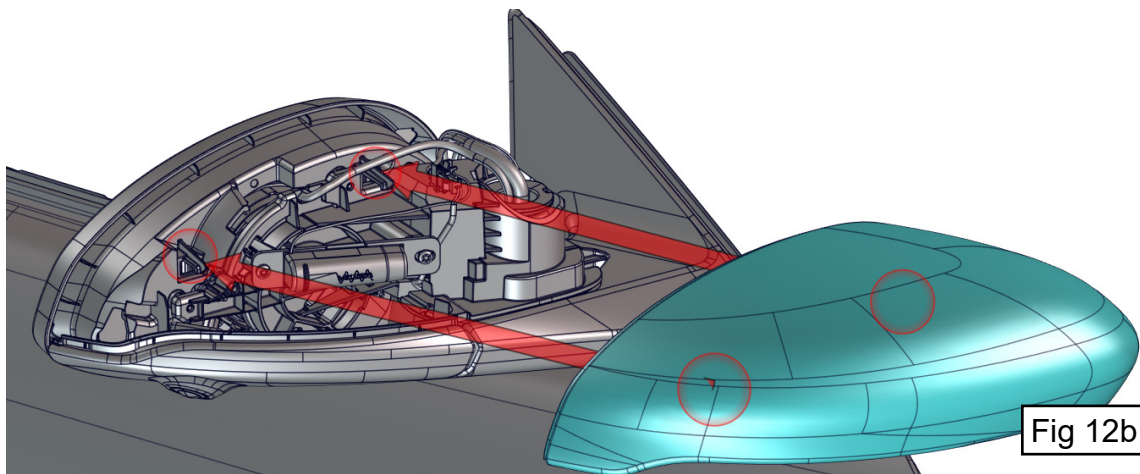
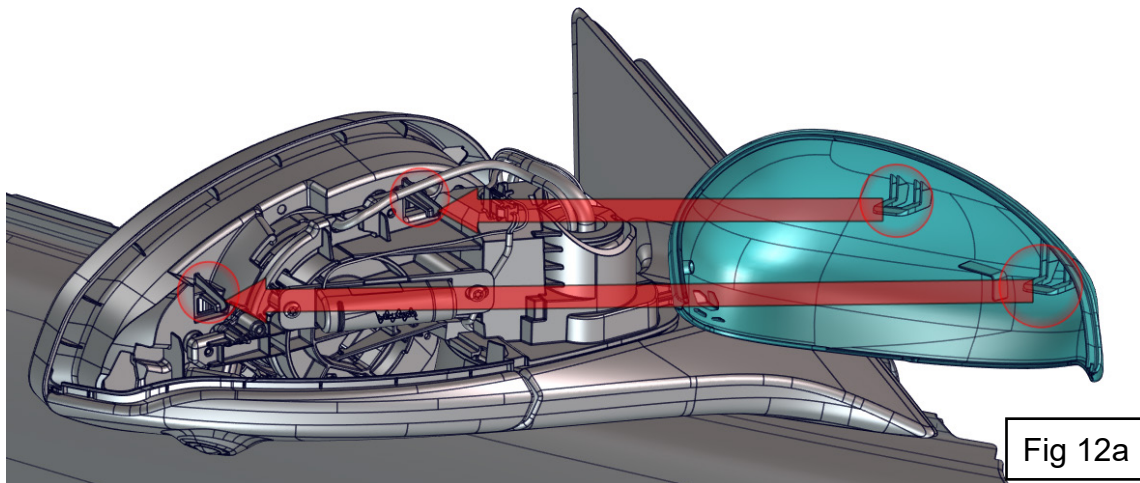

Karma Automotive Bulletins and service documents are intended for use by experienced and trained Technicians. If you lack the skills, tools, equipment and a suitable workshop for any procedure described in this document, we suggest you leave such repairs to a Karma retailer and service provider. See your service provider for advice on whether your vehicle may benefit from the information contained within this document. The information contained in the Karma Bulletin is accurate at the date of publication. However, Karma Automotive regularly updates technical information. Please check with your Karma Automotive Retailer and Karma Automotive service provider that the bulletin you intend to use contains the latest available information.

Title: Orbital Package Install (updated)

Applicability: MY2025 Revero

Remove the front fascia to gain access to the upper grill accent and the grill, or nose piece.

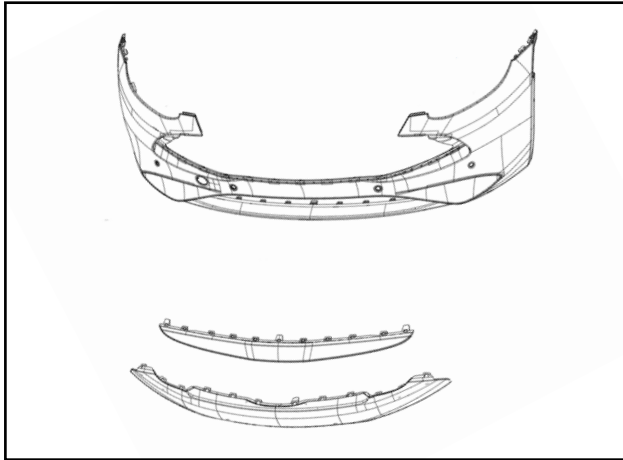

Remove the 10 (ten clips on each liner) begin with the front three body clips, of the wheel liner, on each side (Fig.13a, Fig. 13b).

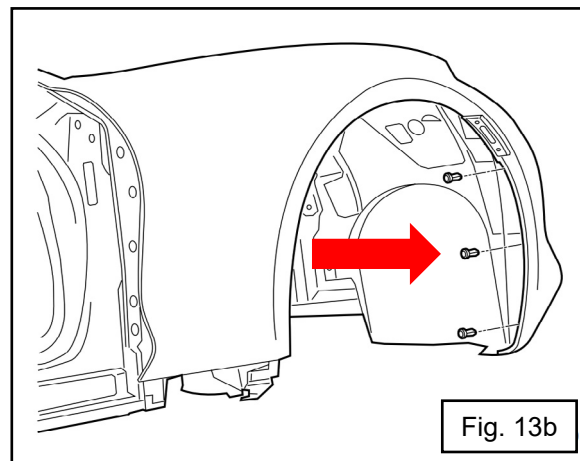
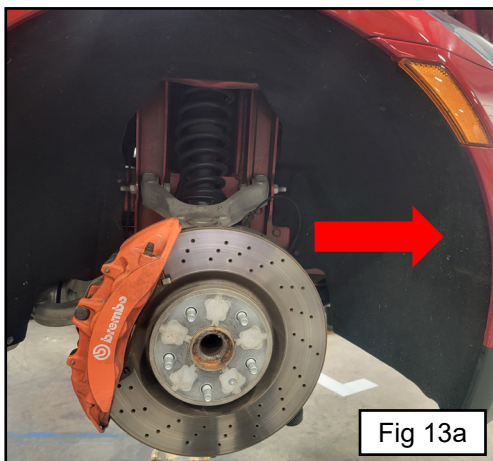

Karma Automotive Bulletins and service documents are intended for use by experienced and trained Technicians. If you lack the skills, tools, equipment and a suitable workshop for any procedure described in this document, we suggest you leave such repairs to a Karma retailer and service provider. See your service provider for advice on whether your vehicle may benefit from the information contained within this document. The information contained in the Karma Bulletin is accurate at the date of publication. However, Karma Automotive regularly updates technical information. Please check with your Karma Automotive Retailer and Karma Automotive service provider that the bulletin you intend to use contains the latest available information.

Title: Orbital Package Install (updated)

Applicability: MY2025 Revero

Continue around the liner and remove the remainder body clips of the wheel liner (Fig.14a, Fig. 14b).

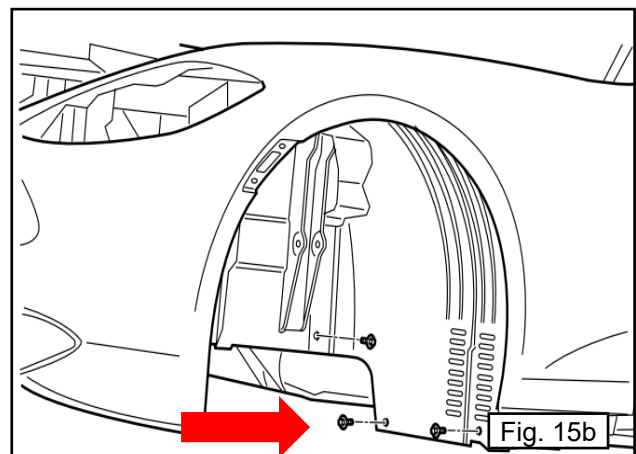
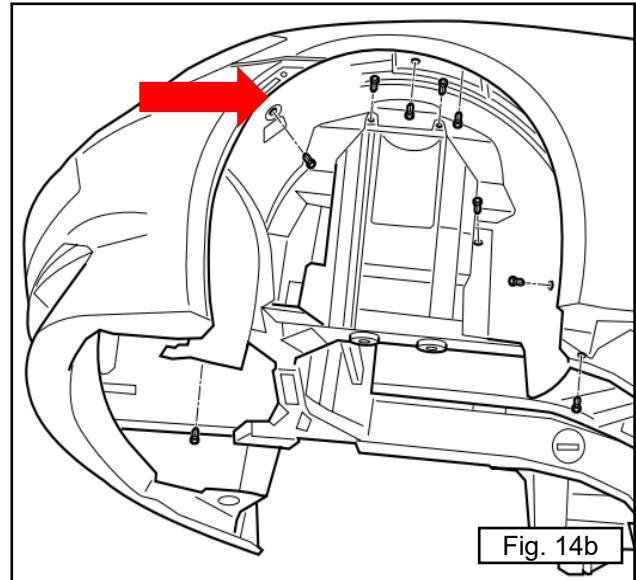
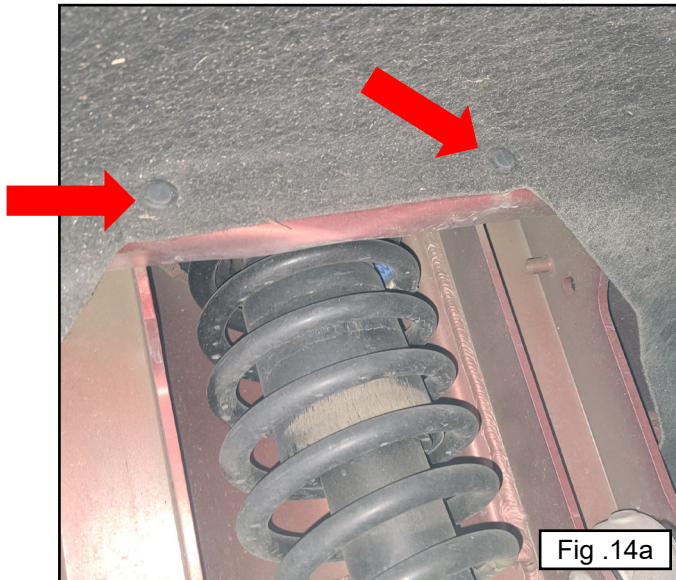

The aluminum wheel liner bracket will stay attached to the wheel liner upon removal (Fig. 15a and Fig.15b).

Karma Automotive Bulletins and service documents are intended for use by experienced and trained Technicians. If you lack the skills, tools, equipment and a suitable workshop for any procedure described in this document, we suggest you leave such repairs to a Karma retailer and service provider. See your service provider for advice on whether your vehicle may benefit from the information contained within this document. The information contained in the Karma Bulletin is accurate at the date of publication. However, Karma Automotive regularly updates technical information. Please check with your Karma Automotive Retailer and Karma Automotive service provider that the bulletin you intend to use contains the latest available information.

Title: Orbital Package Install (updated)

Applicability: MY2025 Revero

With the clips removed, pull down the wheel liner, remove, and set aside (Fig. 16a).

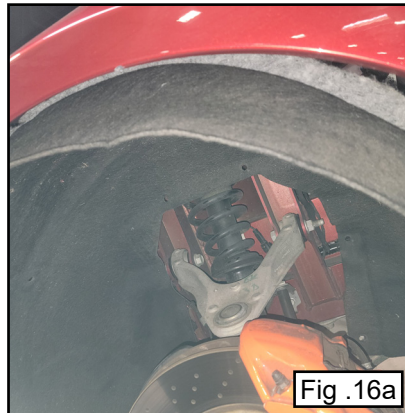

Proceed to remove the clips for the front fascia (Fig. 10b). Look for 4 clips on the underside, 2 LH and 2 RH (Fig. 16c and Fig. 16d).

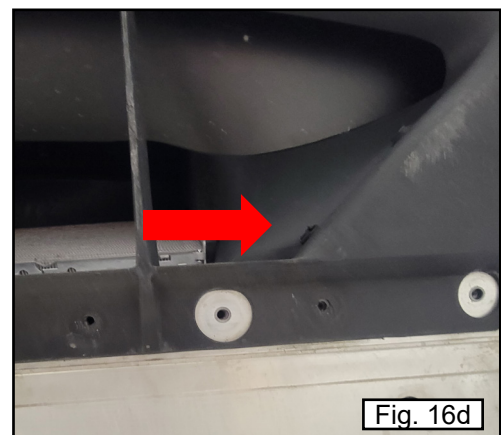
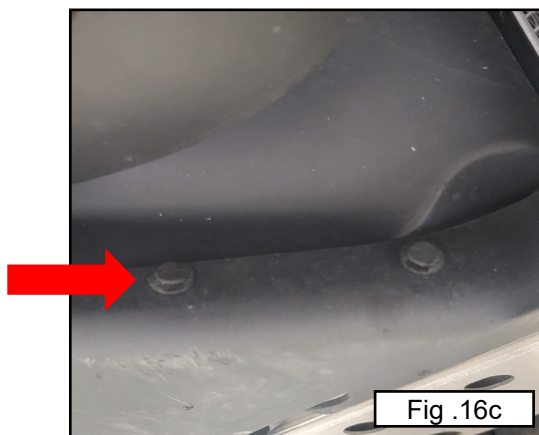

Karma Automotive Bulletins and service documents are intended for use by experienced and trained Technicians. If you lack the skills, tools, equipment and a suitable workshop for any procedure described in this document, we suggest you leave such repairs to a Karma retailer and service provider. See your service provider for advice on whether your vehicle may benefit from the information contained within this document. The information contained in the Karma Bulletin is accurate at the date of publication. However, Karma Automotive regularly updates technical information. Please check with your Karma Automotive Retailer and Karma Automotive service provider that the bulletin you intend to use contains the latest available information.

Title: Orbital Package Install (updated)

Applicability: MY2025 Revero

Remove the (4) 10mm bolts securing LH & RH side air dams to the front bumper fascia (Fig. 17a). Reassembly Torque is 3.5 Nm.

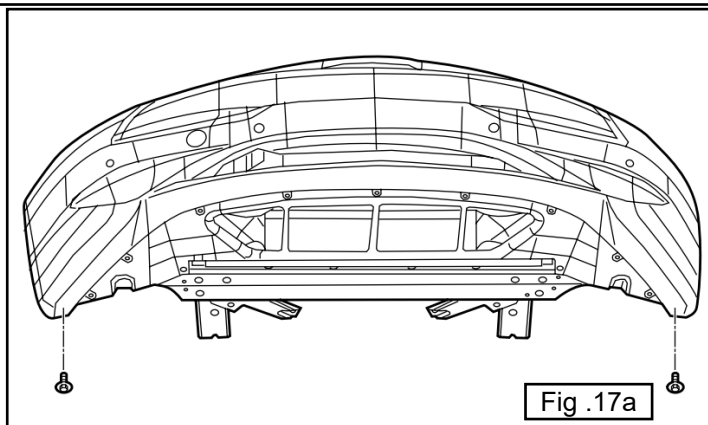

Remove the clips securing the LH and RH side air dams, and center air dam to the front bumper fascia (Fig.17b).

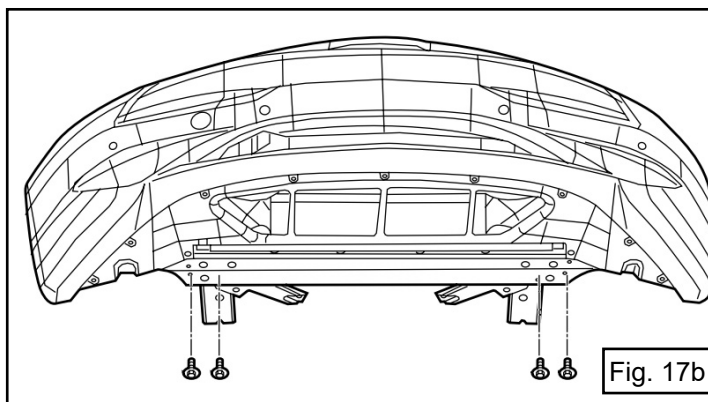

Remove the (6) bolts securing the center air dam to the front bumper fascia (Fig. 17c and Fig. 17d). Reassembly Torque is 4.5 +/-0.5Nm.

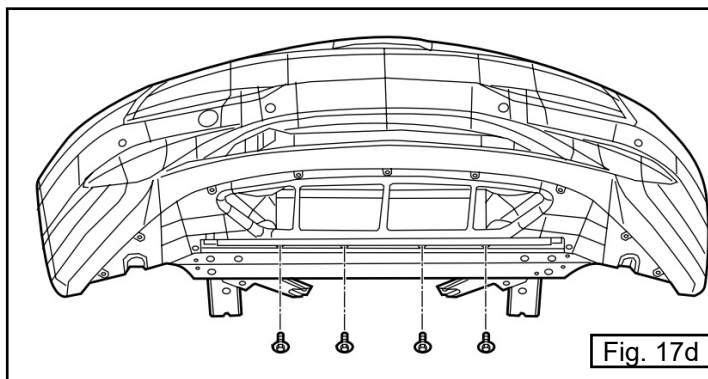

Karma Automotive Bulletins and service documents are intended for use by experienced and trained Technicians. If you lack the skills, tools, equipment and a suitable workshop for any procedure described in this document, we suggest you leave such repairs to a Karma retailer and service provider. See your service provider for advice on whether your vehicle may benefit from the information contained within this document. The information contained in the Karma Bulletin is accurate at the date of publication. However, Karma Automotive regularly updates technical information. Please check with your Karma Automotive Retailer and Karma Automotive service provider that the bulletin you intend to use contains the latest available information.

### Title: Orbital Package Install (updated)

Applicability: MY2025 Revero

Remove the bolt securing fascia to fender.  
Perform on both sides (Fig. 18a, and Fig. 18b) Reassembly Torque is 3.5 Nm.

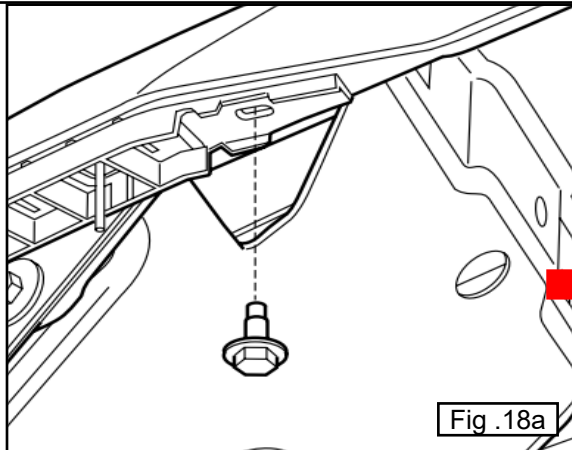

Fig .18a



Fig. 18b

9. Disconnect the electrical harness connectors from fascia harness (left side) (Fig.18c and Fig.18d).

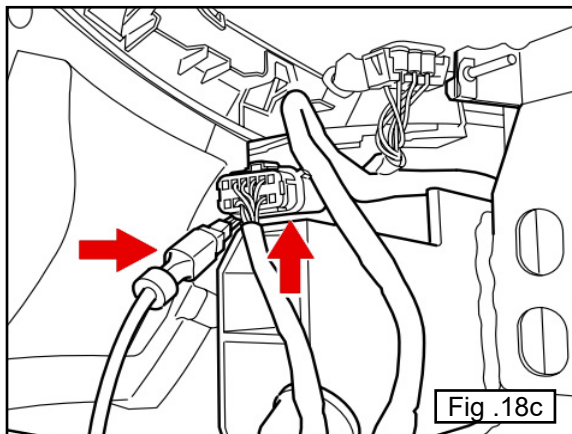

Fig .18c

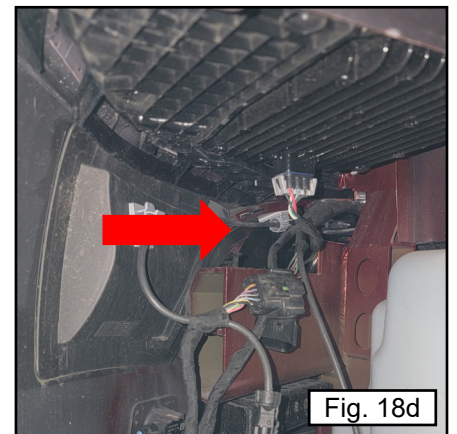

Fig. 18d

10. Using a small tool, slightly open the retainer clip and carefully pull front fascia from the clip retainer. Perform on both sides (Fig.18e and Fig.18f).

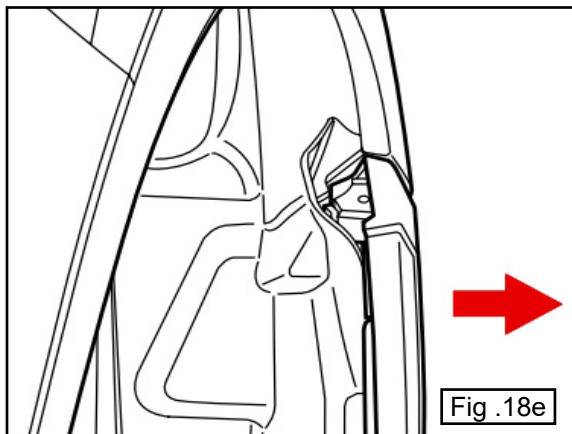

Fig .18e

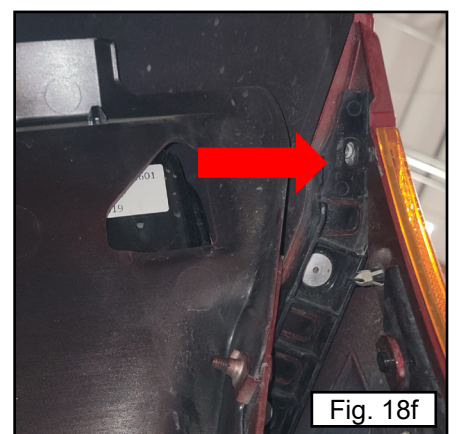

Fig. 18f

Karma Automotive Bulletins and service documents are intended for use by experienced and trained Technicians. If you lack the skills, tools, equipment and a suitable workshop for any procedure described in this document, we suggest you leave such repairs to a Karma retailer and service provider. See your service provider for advice on whether your vehicle may benefit from the information contained within this document. The information contained in the Karma Bulletin is accurate at the date of publication. However, Karma Automotive regularly updates technical information. Please check with your Karma Automotive Retailer and Karma Automotive service provider that the bulletin you intend to use contains the latest available information.

### Title: Orbital Package Install (updated)

Applicability: MY2025 Revero

Remove the (6) T30 bolts securing the fascia to the front support (Fig. 19a and Fig. 19b). Reassembly Torque is 3.5 Nm.

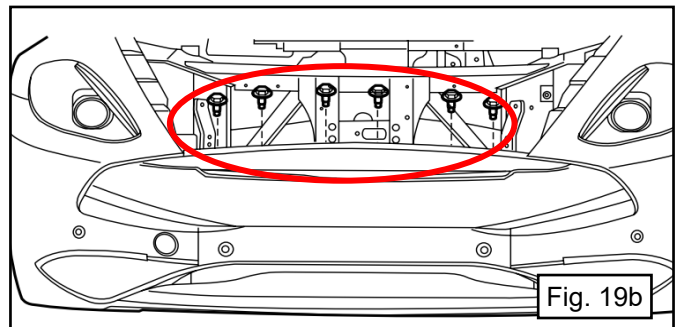

Carefully pull the fascia from the side support bracket retaining tabs to release the fascia from the clips (Fig. 20a). Reassembly Torque is 3.5 Nm.

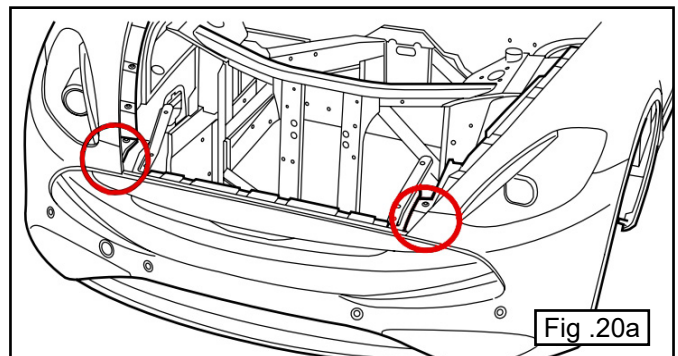

**Important:** If the side support bracket retaining clip(s) are damaged, or if the front fascia side support bracket(s) must be replaced (Fig. 20b).

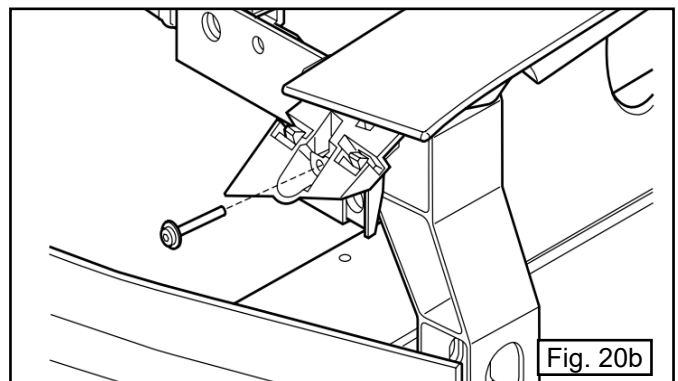

Karma Automotive Bulletins and service documents are intended for use by experienced and trained Technicians. If you lack the skills, tools, equipment and a suitable workshop for any procedure described in this document, we suggest you leave such repairs to a Karma retailer and service provider. See your service provider for advice on whether your vehicle may benefit from the information contained within this document. The information contained in the Karma Bulletin is accurate at the date of publication. However, Karma Automotive regularly updates technical information. Please check with your Karma Automotive Retailer and Karma Automotive service provider that the bulletin you intend to use contains the latest available information.

**Title:** Orbital Package Install (updated)

**Applicability:** MY2025 Revero

**Type:** Technical Bulletin

**Year:** 2025

**System:** Body (70)

**Sequence:** 01 Revision: 3

With assistance, remove the front fascia/bumper assembly. Have a bumper cover stand or a cloth covered table ready to place it on (Fig. 22a and Fig.22b). Provide images of this step for the TSS case.

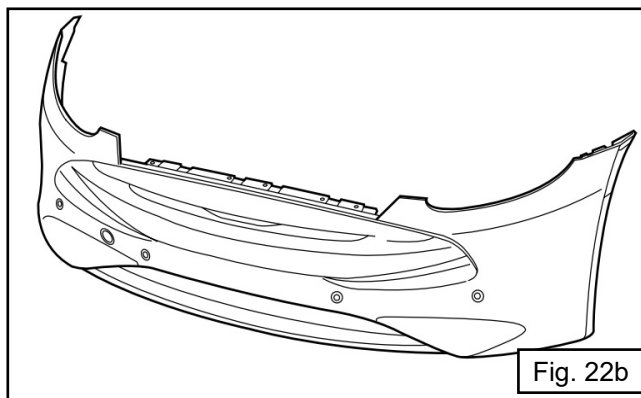

The fascia components (upper grille piece, and the upper grille accent) will be replaced with the Distinction Package components. These will be in a gloss black finish. With the fascia on the bench, proceed to remove the two components and replace them as directed.



On the fascia load the upper grille from the front side of the fascia. Use the center tab highlighted (Fig. 23a) start securing the snap securing the bezel and finalize the assembly with the last two tabs into the fascia (Fig. 23b).

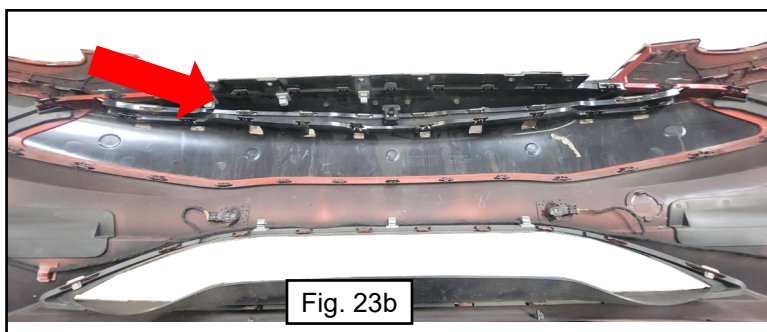
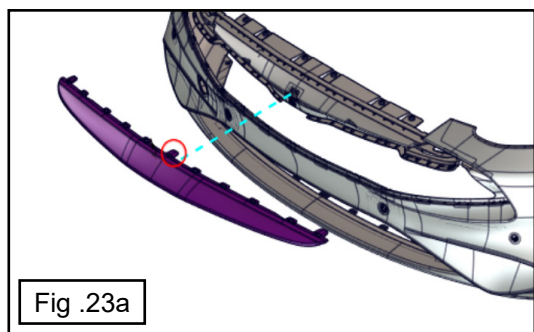

Karma Automotive Bulletins and service documents are intended for use by experienced and trained Technicians. If you lack the skills, tools, equipment and a suitable workshop for any procedure described in this document, we suggest you leave such repairs to a Karma retailer and service provider. See your service provider for advice on whether your vehicle may benefit from the information contained within this document. The information contained in the Karma Bulletin is accurate at the date of publication. However, Karma Automotive regularly updates technical information. Please check with your Karma Automotive Retailer and Karma Automotive service provider that the bulletin you intend to use contains the latest available information.

**Title: Orbital Package Install (updated)**

**Applicability:** MY2025 Revero

Install the new badging on the hood and decklid (Fig 24a and 24b). Using a badge application tool (a kit C271162900300 available from Karma). The Kit with the badge fixtures has instructions available to mount and install the badging.



Karma Automotive Bulletins and service documents are intended for use by experienced and trained Technicians. If you lack the skills, tools, equipment and a suitable workshop for any procedure described in this document, we suggest you leave such repairs to a Karma retailer and service provider. See your service provider for advice on whether your vehicle may benefit from the information contained within this document. The information contained in the Karma Bulletin is accurate at the date of publication. However, Karma Automotive regularly updates technical information. Please check with your Karma Automotive Retailer and Karma Automotive service provider that the bulletin you intend to use contains the latest available information.

Title: Orbital Package Install (updated)

Applicability: MY2025 Revero

Removal of the original valance panel (diffuser) can be performed with the rear fascia still installed. The panel is unfastened on the leading edge (7) fasteners (Fig. 25a), Reassembly torque 5 +/- 0.5 Nm, take note of the reverse lamp attached on the inside (Fig. 25b), as you must pull firmly toward the rear of the car to pull off the diffuser, a small panel tool can be used to spread apart the panel locator tab (Fig. 8c). The reverse lamp will be transferred over to the new diffuser, (Fig. 25d) also fastened at Torque – Reassembly torque 0.6 +/- 0.1 Nm. When the panel is removed be mindful to disconnect the reverse light connector.

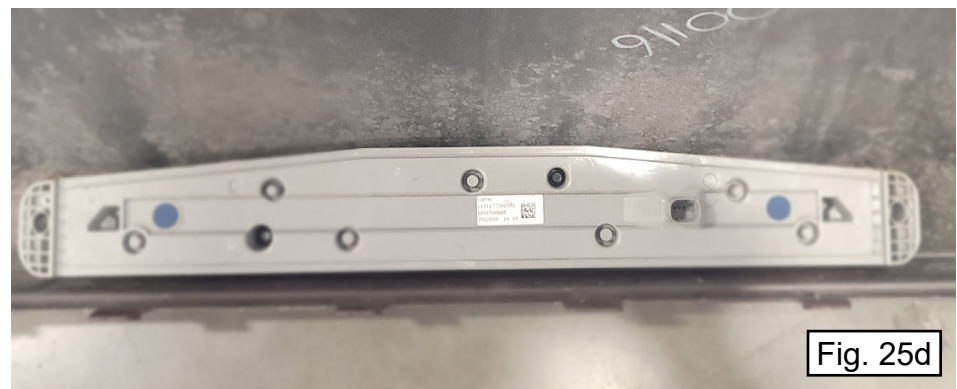
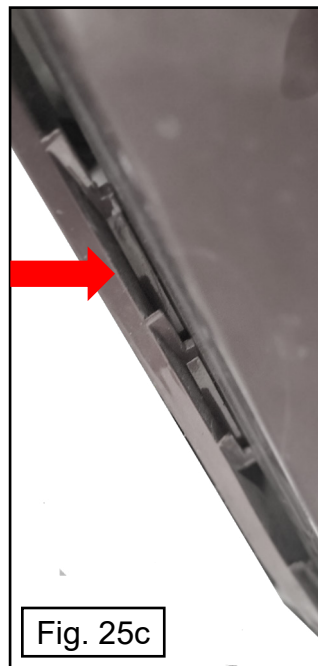
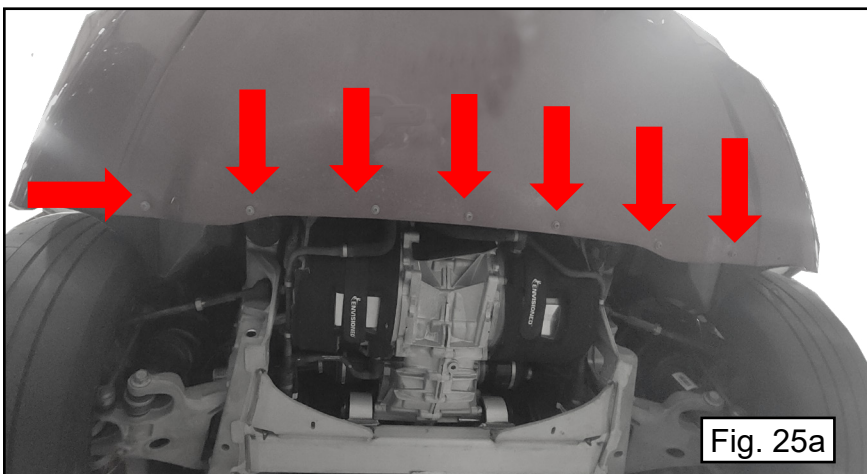

Karma Automotive Bulletins and service documents are intended for use by experienced and trained Technicians. If you lack the skills, tools, equipment and a suitable workshop for any procedure described in this document, we suggest you leave such repairs to a Karma retailer and service provider. See your service provider for advice on whether your vehicle may benefit from the information contained within this document. The information contained in the Karma Bulletin is accurate at the date of publication. However, Karma Automotive regularly updates technical information. Please check with your Karma Automotive Retailer and Karma Automotive service provider that the bulletin you intend to use contains the latest available information.

Title: Orbital Package Install (updated)

Applicability: MY2025 Revero

Installation is the reverse of removal. Use the middle locator tab to position the Rear Diffuser to the fascia. Align all tabs into the assigned holes. (Fig. 26a)

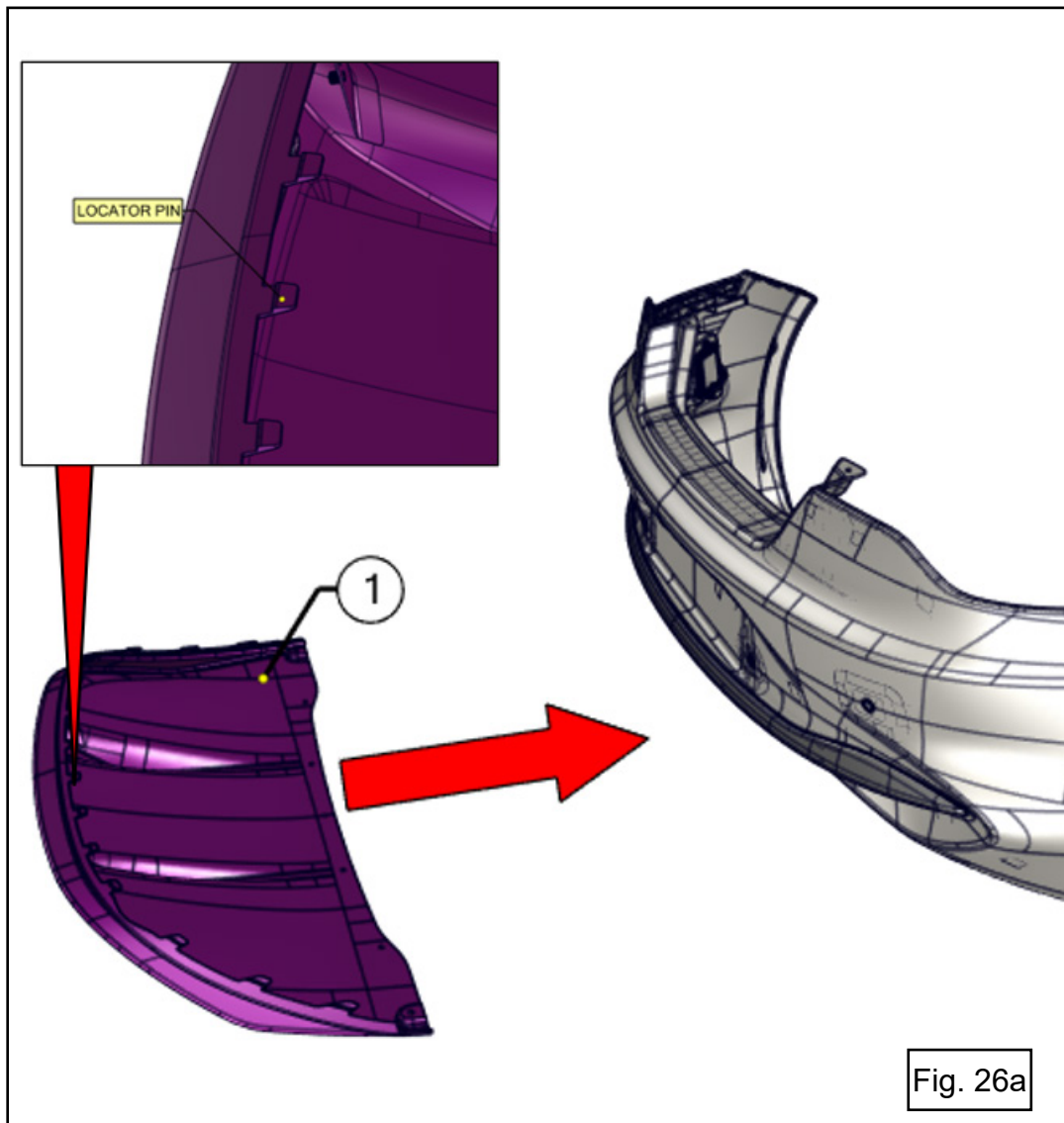

Karma Automotive Bulletins and service documents are intended for use by experienced and trained Technicians. If you lack the skills, tools, equipment and a suitable workshop for any procedure described in this document, we suggest you leave such repairs to a Karma retailer and service provider. See your service provider for advice on whether your vehicle may benefit from the information contained within this document. The information contained in the Karma Bulletin is accurate at the date of publication. However, Karma Automotive regularly updates technical information. Please check with your Karma Automotive Retailer and Karma Automotive service provider that the bulletin you intend to use contains the latest available information.

Title: Orbital Package Install (updated)

Applicability: MY2025 Revero

Push the Diffuser snap features and ensure full installation of each one.(Fig.26b)

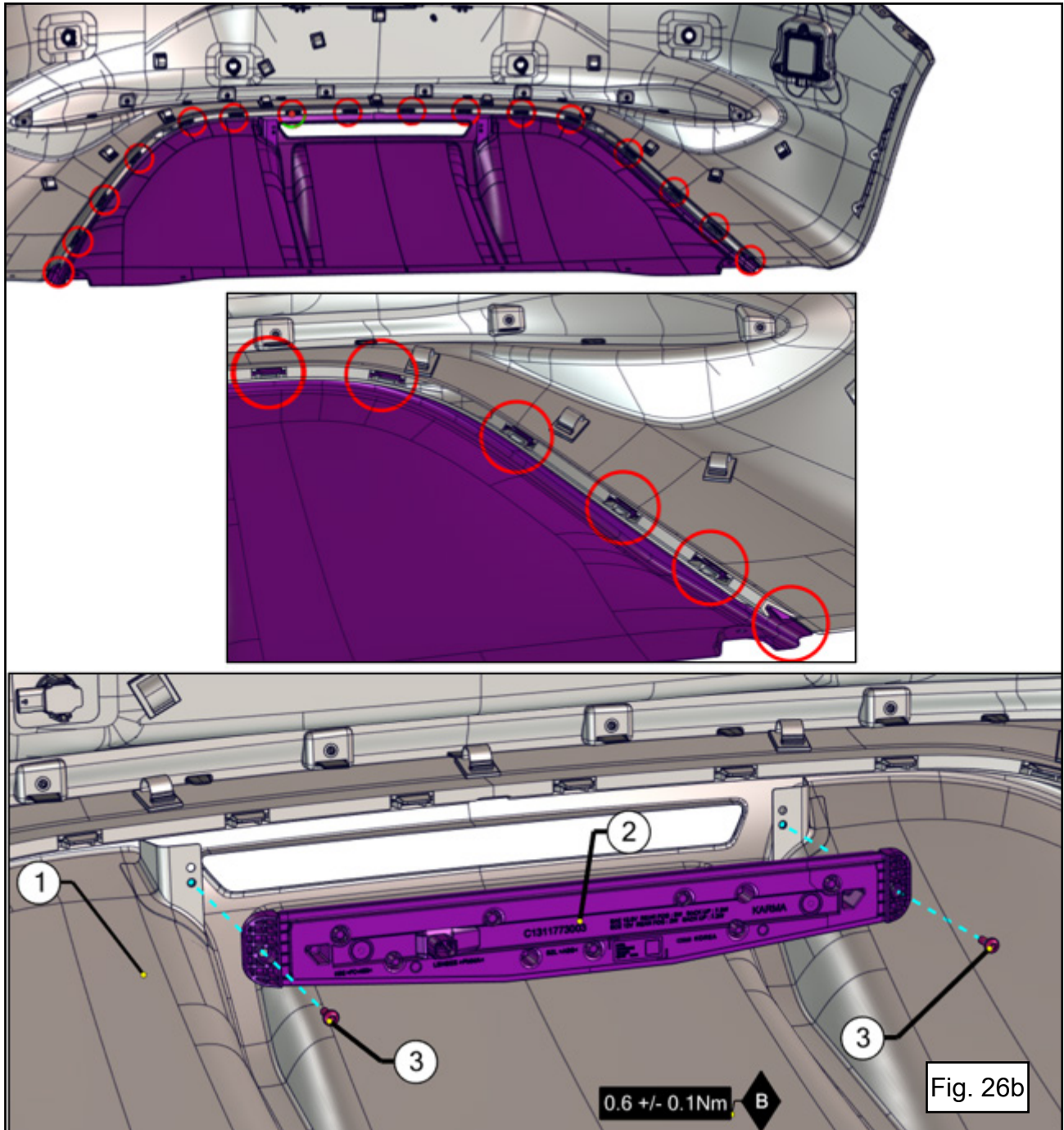

Fig. 26b

Karma Automotive Bulletins and service documents are intended for use by experienced and trained Technicians. If you lack the skills, tools, equipment and a suitable workshop for any procedure described in this document, we suggest you leave such repairs to a Karma retailer and service provider. See your service provider for advice on whether your vehicle may benefit from the information contained within this document. The information contained in the Karma Bulletin is accurate at the date of publication. However, Karma Automotive regularly updates technical information. Please check with your Karma Automotive Retailer and Karma Automotive service provider that the bulletin you intend to use contains the latest available information.



TB-25-70-01.3

Type: Technical Bulletin

Year: 2025

System: Body (70)

Sequence: 01 Revision: 3

Title: Orbital Package Install (updated)

Applicability: MY2025 Revero

Tools Required:

PART NUMBER	DESCRIPTION
C271162900300	Badge mounting fixtures w

PARTS REQUIRED:

PART NUMBER	DESCRIPTION	QTY
	Karma Script Badge (black)	2
	OA - Accent Grille Upper - Fascia Front GLOSS BLACK GRILLE BLADE	1
	OA - Gloss Black Grille - Upper K1 2.0	1
	OA - Painted Mirror Scalp LH Cyan GLOSS BLACK SIDE MIRROR CAPS LH	1
	OA - Painted Mirror Scalp LH Cyan GLOSS BLACK SIDE MIRROR CAPS RH	1
	OA - Rocker Panel Accent - Carbon Fiber Gel Coated Black – LH - Cyan	1
	OA - Rocker Panel Accent - Carbon Fiber Gel Coated Black – RH - Cyan	1
	OA - Cover - Valance Lower Rear - Cyan	1
	Tire - LRR PZ4 245-40 R21 Front	2
	Tire - LRR PZ4 265-40 R21 Rear	2
	Wheel - Five Spoke Forged 21 x 8.5 Front (Racer's Edge)	2
	Wheel - Five Spoke Forged 21 x 9.0 Rear (Racer's Edge)	2
	SCREW-PANHEAD TORX M5 X 0.8 X 16.0 PC8	8
	Rivet-pop 3.2 x 4.8	12
	Nut- Hex Keps Flat M^ X 1.0 X19.0 PC8	2
	Clip- Quarter Turn w Base 9.0 Mod	2
	Clip Quarter Turn w Base 9.0	16
	Sensor - Tire Pressure Monitor System	4
	Nut - Tire Pressure Monitor Sensor	4
	Wheel Center Cap -Gloss black (Karma word mark)	4

LABOR CODES:

CODE	DESCRIPTION	TIME	DEFECT CODE
95-02-01-02	Distinction Kit Install	3.7	95-02-01-01

CAUSAL PART:

PART NUMBER	DESCRIPTION
C131173700303	Cover - Valance Lower Rear

WARRANTY DISPOSITION:

The claim cannot be processed without full compliance of this bulletin. Ensure the following have been performed: Images and repair order have been attached to the warranty claim and submitted to Karma Automotive Inc.

Karma Automotive Bulletins and service documents are intended for use by experienced and trained Technicians. If you lack the skills, tools, equipment and a suitable workshop for any procedure described in this document, we suggest you leave such repairs to a Karma retailer and service provider. See your service provider for advice on whether your vehicle may benefit from the information contained within this document. The information contained in the Karma Bulletin is accurate at the date of publication. However, Karma Automotive regularly updates technical information. Please check with your Karma Automotive Retailer and Karma Automotive service provider that the bulletin you intend to use contains the latest available information.