



# TECHNICAL SERVICE BULLETIN

## Chatter/Shudder During Low Speed Turning Events

**26-2194**

24 April 2026

This bulletin supersedes 25-2627. Reason for update: update the TSB Action, and TSB Service Procedure to add a Step to reprogram the AWD module for Bronco Sport vehicles.

**Model:**

<b>Ford</b>
2021-2024 Bronco Sport
2019-2024 Edge
2020-2024 Escape
2022-2024 Maverick
<b>Lincoln</b>
2020-2024 Corsair
2019-2023 Nautilus

**Markets:** North American markets only

**Issue:** Some of the vehicles listed in the Model statement above may exhibit all of the following conditions:

- Shudder chatter condition, most noticeable at low speeds turning.
- No relevant DTCs present.

This may be due to internal RDU fluid contamination.

**Action:** For vehicles that meet all the criteria in the Issue and Model statements, follow the applicable Service Procedure steps to repair the vehicle.

**Parts**

Service Part Number	Claim Quantity	Description	Note
W720472-S439	4	Caliper Bolt (Maverick, Bronco Sport, Escape only)	
W719466-S439	8	Wheel Hub Bolt (Maverick, Bronco Sport, Escape only)	
K2GZ-4022-M	1	RDU Vent Hose (Bronco Sport 1.5L, Escape 1.5L/2.0L)	
LX6Z-4022-C	1	RDU Vent Hose (Bronco Sport 2.0L)	
LX6Z-4022-H	1	RDU Vent Hose (Escape 2.5L FHEV)	
K2GZ-7C108-A	1	RDU Clutch Kit	
W720080-S439	3	RDU Mount Bolt	
LX6Z-5A215-D	1	Exhaust Clamp	
LX6Z-4B496-A	1	Driveshaft Bolt Kit	One Kit Contains 3 pcs.
NZ6Z-3B498-A	2	Axle Cir-clip Retainer	
CCPZ-3B477-B	2	Axle Nut	

CV6Z-4B416-D	2	Axle Seal	
W718014-S450	1	Stud Rivet	
6C2Z-4N282-AA	1	Drain Plug	
SU7Z-19B508-A	0.5	Flange Sealant Adhesive	
Obtain Locally	As Needed	Loctite 6338	
XY-75W-QL	As Needed	Motorcraft® SAE 75W Disconnect Rear Drive Unit Fluid	
PM-4-A	As Needed	Motorcraft® Metal Brake Parts Cleaner (Compliant With Low Volatile Organic Compound Requirements As Required In Some USA States)	
PM-4-B	As Needed	Motorcraft® Metal Brake Parts Cleaner (Not Compliant With Volatile Organic Compound Requirements)	
CPM-4-A	As Needed	Motorcraft® Metal Brake Parts Cleaner (Not Compliant With Volatile Organic Compound Requirements)	
XL-2	As Needed	Motorcraft® High Temperature Nickel Anti-Seize Lubricant	
TA-2-B	As Needed	Motorcraft® Seam Sealer	

### Parts - Corsair Only

Service Part Number	Claim Quantity	Description
W720473-S439	4	Caliper Bolt
W720079-S900	2	RDU Bolt
W720678-S439	4	Wheel Hub Bolt
W720526-S450B	4	Fuel Tank Strap Fastener
K2GZ-4022-L	1	RDU Vent Hose

**Claim Quantity** refers to the total number of individual pieces required to repair the vehicle. This may differ from the number of service part number packages due to the unit of issue (UOI).

**As Needed** indicates the part is necessary but amount of the part may vary and/or is not a whole number. Parts can be billed out as non-whole numbers, including less than 1.

**Only If Necessary** indicates the part is not mandatory. Refer to the Service Procedure to determine the inspection/inclusion criteria.

**Warranty Status:** Warranty coverage limits and policies are not altered by a TSB. Warranty coverage limits are determined by the identified causal part.

### Labor Times

Description	Operation No.	Time
2019-2024 Edge, 2019-2023 Nautilus: Drain And Refill The RDU (Do Not Use With Any Other Labor Operations)	262194A	0.4 Hrs
2021-2024 Bronco Sport 2.0L EcoBoost: Perform RDU Vent Service Procedure (Can Be Claimed With Labor Operation L)	262194B	0.8 Hrs
2021-2024 Bronco Sport 1.5L EcoBoost: Install The Internal Clutch Pack Service Kit, Inspect RDU Vent Hose (Can Be claimed With Operation K And L)	262194C	6.1 Hrs
2020-2024 Corsair: Install The Internal Clutch Pack Service Kit, Inspect RDU Vent Hose (Can Be claimed With Operation J)	262194D	8.2 Hrs
2020-2024 Escape 1.5L EcoBoost: Install The Internal Clutch Pack Service Kit, Inspect RDU Vent Hose (Can Be Claimed With Operation J)	262194E	6.1 Hrs
2020-2024 Escape 2.0L EcoBoost: Install The Internal Clutch Pack Service Kit, Inspect RDU Vent Hose (Can Be Claimed With Operation J)	262194F	6.0 Hrs

2020-2024 Escape 2.5L HEV: Install The Internal Clutch Pack Service Kit, Inspect RDU Vent Hose (Can Be Claimed With Operation J)	262194G	6.1 Hrs
2022-2024 Maverick 2.0L EcoBoost: Install The Internal Clutch Pack Service Kit (Do Not Use With Any Other Labor Operations)	262194H	5.6 Hrs
2020-2022 Escape/Corsair AWD: Extra Time To Replace The RDU Vent Hose Following The Service Procedure (Can Be Claimed With Labor Operations D, E, F Or G)	262194J	0.6 Hrs
2021-2023 Bronco Sport 1.5L: Extra Time To Replace The RDU Vent Hose Following The Service Procedure (Can Be Claimed With Labor Operation C And L)	262194K	0.6 Hrs
2021-2024 Bronco Sport: Reprogram The AWD Module Includes Time To Connect FDRS and Battery Charger (Can Be Claimed With Labor Operation B, C, K)	262194L	0.2 Hrs

### Repair/Claim Coding

Causal Part:	7C108
Condition Code:	14

## Service Procedure

- Is the vehicle a 2019-2024 Edge or 2019-2023 Nautilus?
  - Yes - drain and fill the RDU. Refer to WSM, Section 205-02A. Repair is complete.
  - No - proceed to Step 2.
- Is the vehicle a 2021-2024 Bronco Sport equipped with 2.0L EcoBoost engine and twin active torque coupling differential?
  - Yes - proceed to RDU Vent Service Procedure.
  - No - proceed to Internal Clutch Pack Service Procedure.

## Internal Clutch Pack Service Procedure

- Remove the rear axle assembly. Refer to WSM, Section 205-02 > Rear Drive Axle/Differential.
- Replace the internal clutch assembly. Refer to WSM, Section 205-02 > Rear Drive Axle/Differential > Internal Clutch Pack.

**NOTE: Utilize flange sealant adhesive.**

- For Maverick vehicles only, proceed to Step 28 in the RDU Vent Service Procedure.
- For Bronco Sport/Escape/Corsair vehicles, proceed to RDU Vent Service Procedure.

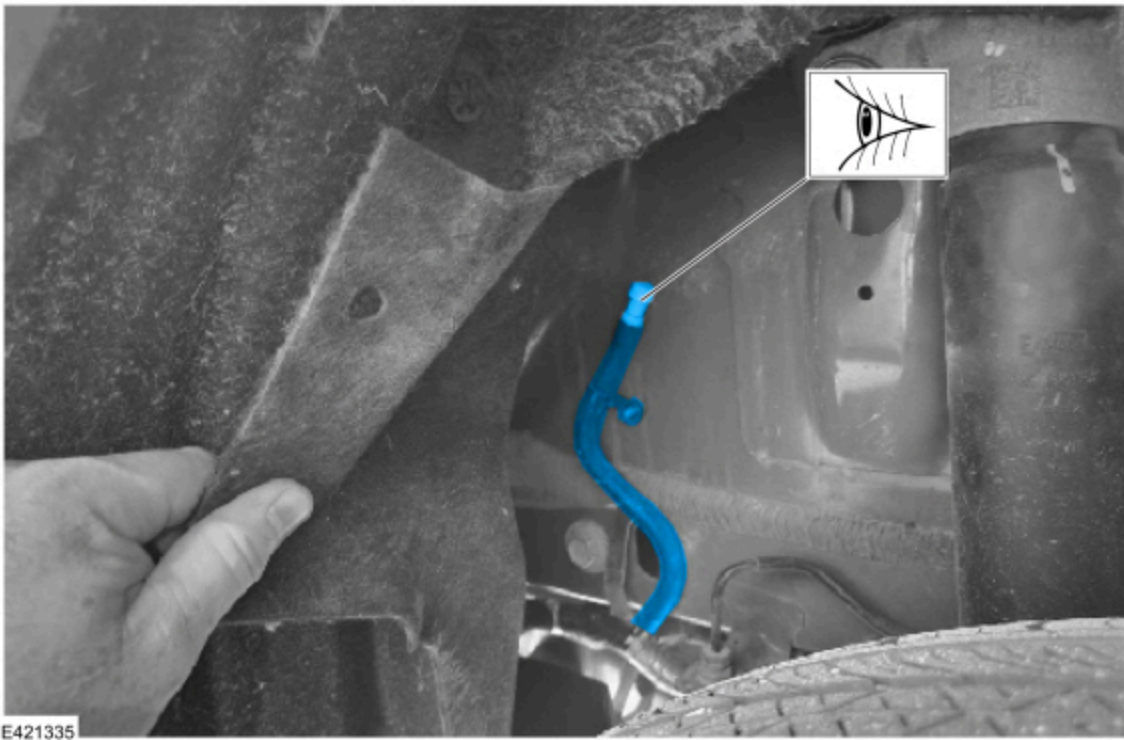
## RDU Vent Service Procedure

- Remove the right rear fender splash shield retaining pin and fold back the right rear fender splash shield to inspect the RDU vent hose. (Figures 1-2)

Figure 1

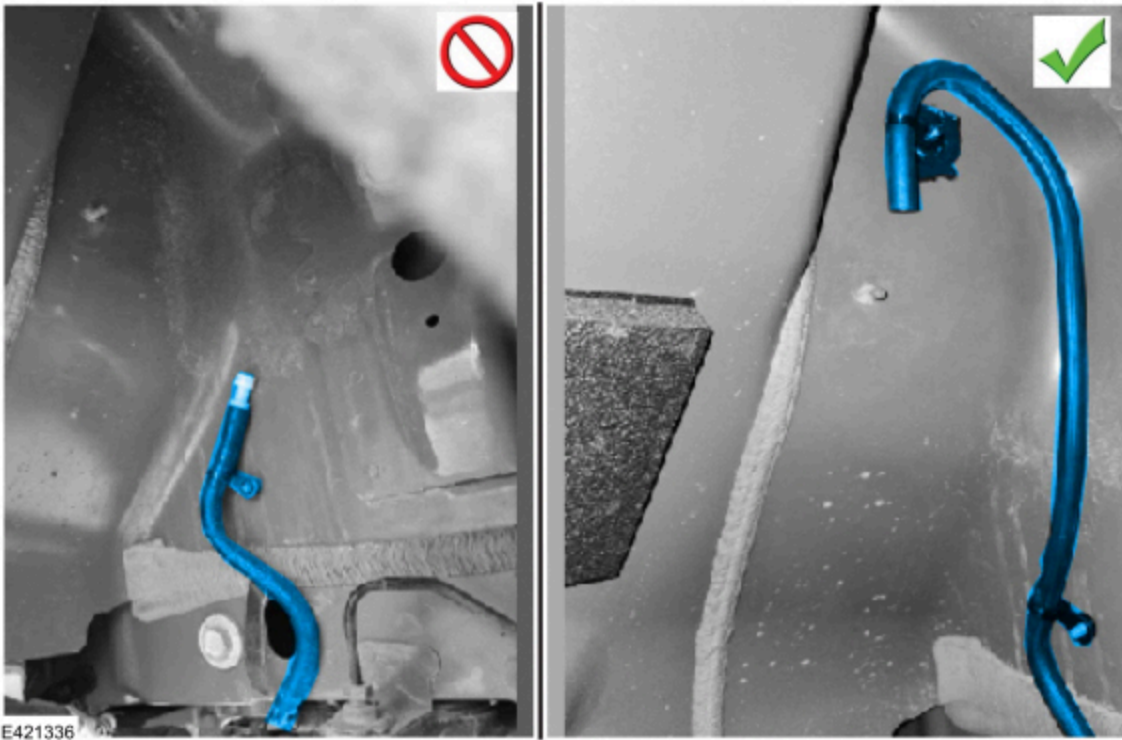


Figure 2



2. Inspect the RDU vent hose mounted behind the right rear fender splash shield. Is the vehicle equipped with the updated RDU vent hose as shown in the image with the green check mark in Figure 3?

Figure 3



(1). Yes - this vent service procedure does not apply. Proceed to Step 29.

(2). No - proceed to Step 3.

**3.** Remove the right rear wheel. Refer to WSM, Section 204-04A.

**4.** Remove the retainers and screws from the right rear fender splash shield shown in Figures 4-6. Lower and fold the right rear fender splash shield in front of the brake caliper to access the RDU vent hose and upper section of the wheel well.

Figure 4



E421337

Figure 5

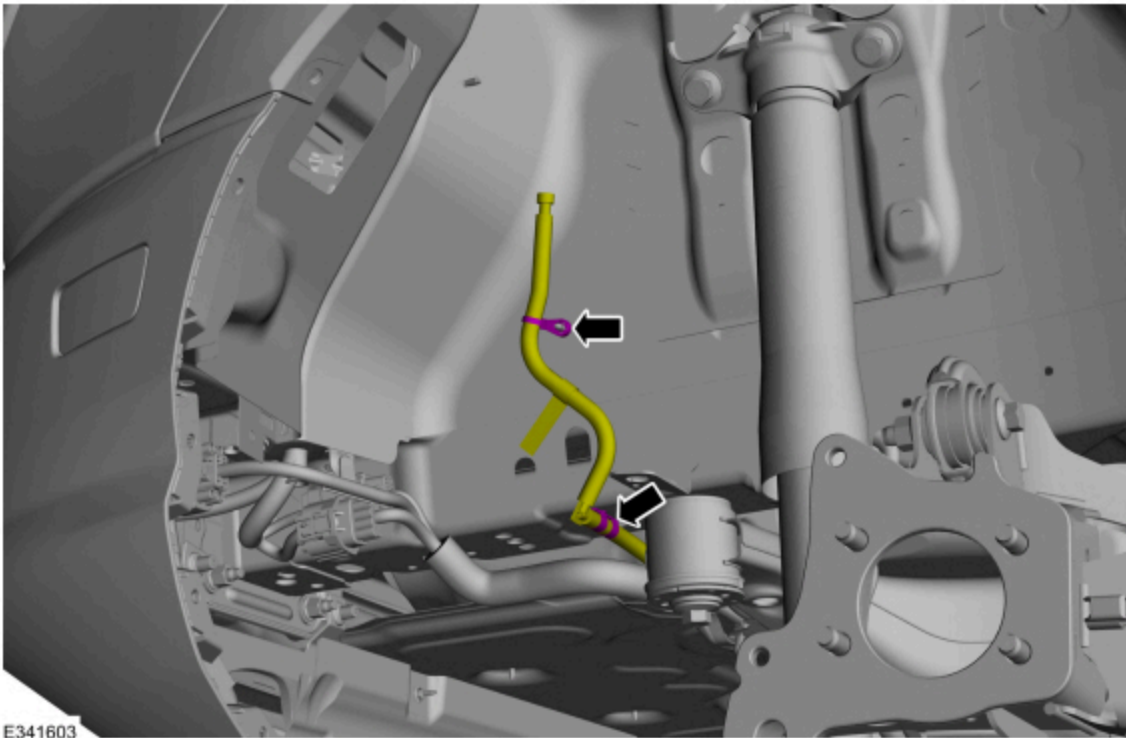


Figure 6

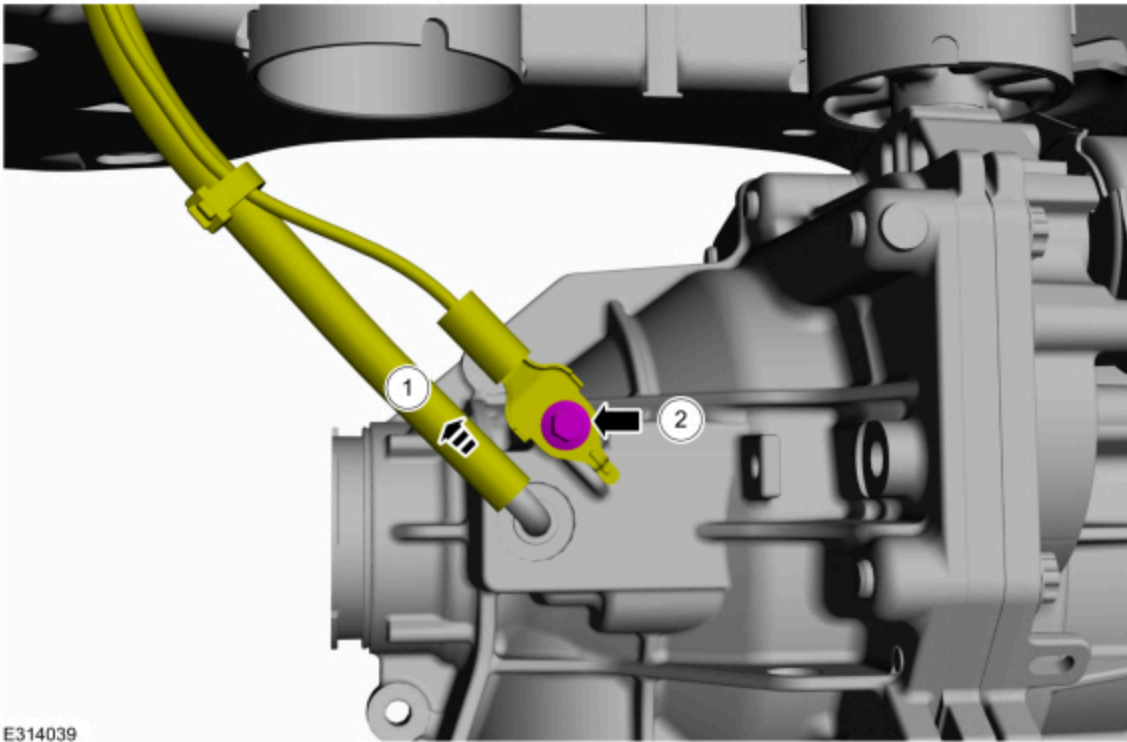


5. Disconnect the RDU vent hose retainers. (Figure 7)

Figure 7



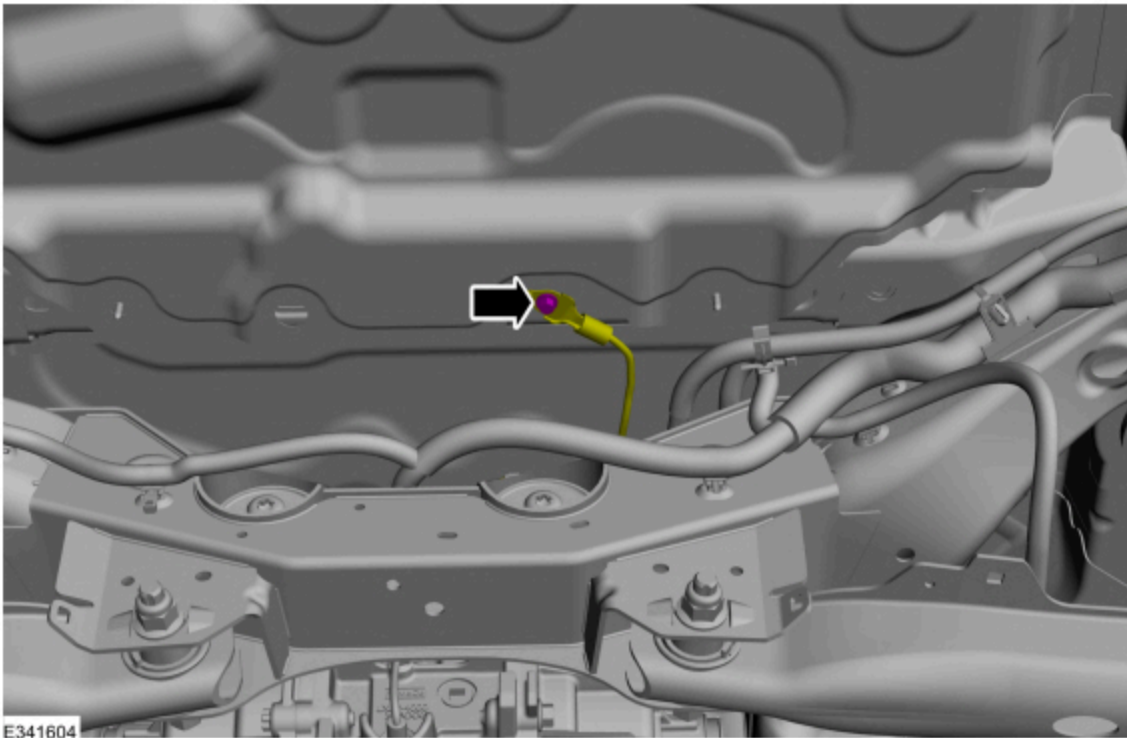
- 6.** Is the vehicle a 2021-2024 Bronco Sport equipped with a 2.0L EcoBoost engine with twin active torque coupling differential?
- (1). Yes - proceed to Step 7.
  - (2). No - proceed to Step 11.
- 7.** Locate the 2 wire ties that secure the RDU vent hose and ground cable together.
- 8.** Cut the 2 wires ties, disconnect the RDU vent hose from the RDU vent port, detach hose retainers and remove the RDU vent hose, leaving the original ground cable in place and secured.
- 9.** On the new replacement RDU vent hose assembly, cut the 2 wire ties and discard the ground strap.
- 10.** Install the new RDU vent hose onto the RDU and attach the hose retainers. Proceed to Step 18.
- 11.** Remove the rear differential vent hose and ground strap bolt from the RDU and position aside. (Figure 8)
- Figure 8 - Bronco Sport 1.5L/Escape/Corsair shown



E314039

12. Remove the ground strap bolt from the body. (Figure 9)

Figure 9



E341604

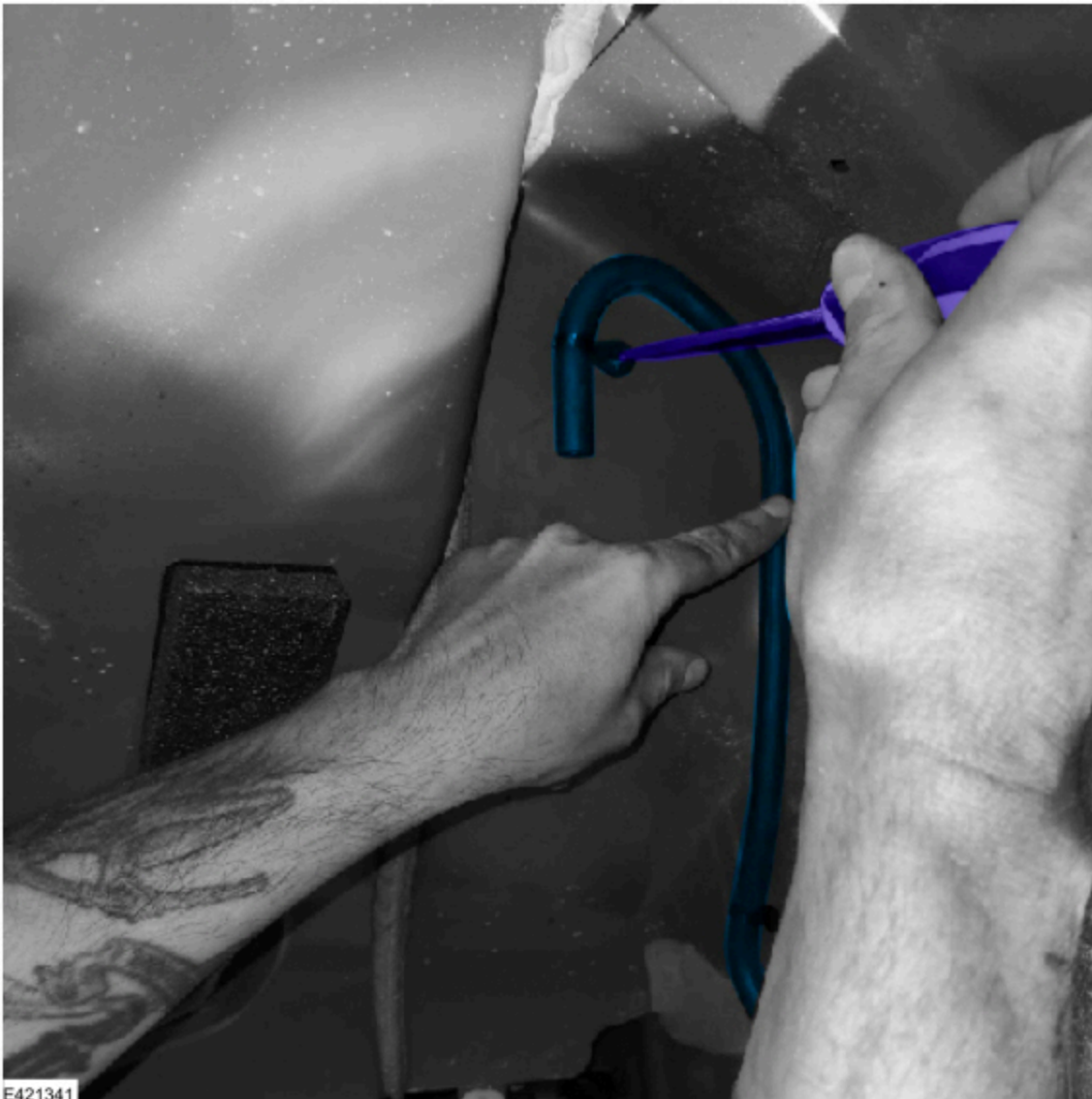
13. Detach the hose retainer and remove the RDU vent hose and ground cable assembly. (Figure 10)

Figure 10



14. Position the new RDU vent hose and ground strap assembly and attach the hose retainers. (Figures 7 and 10)
15. Install the bolt to attach the ground strap to the body. Tighten to 12 Nm (106 lb.in). (Figure 9)
16. Install the new RDU vent hose onto the RDU. (Figure 8)
17. Install the bolt to secure the ground cable onto the RDU. Tighten to 12 Nm (106 lb.in). (Figure 8)
18. Using the new retainer at the end of the new RDU vent hose, position the hose vertically so the form of the hose follows the inner arch of the wheel well. Use a tool or a marker to mark the location on the body to drill a hole. (Figure 11)

Figure 11



19. Position the RDU vent hose aside.



**CAUTION: A depth stopper on the drill bit is necessary to prevent damage to the interior trim.**

20. Using a 10 mm (25/64 in.) drill bit with a depth stopper that leaves only 7 mm (1/4 in.) of the end of the drill bit exposed, drill a hole at the location marked in Step 18.

21. Deburr and clean the hole drilled in Step 20. Temporarily dry fit the stud rivet in the body to make sure the stud rivet is properly seated, then remove the stud rivet.

22. Apply a generous amount of Motorcraft® Seam Sealer to the body side of the stud rivet. (Figure 12)

Figure 12



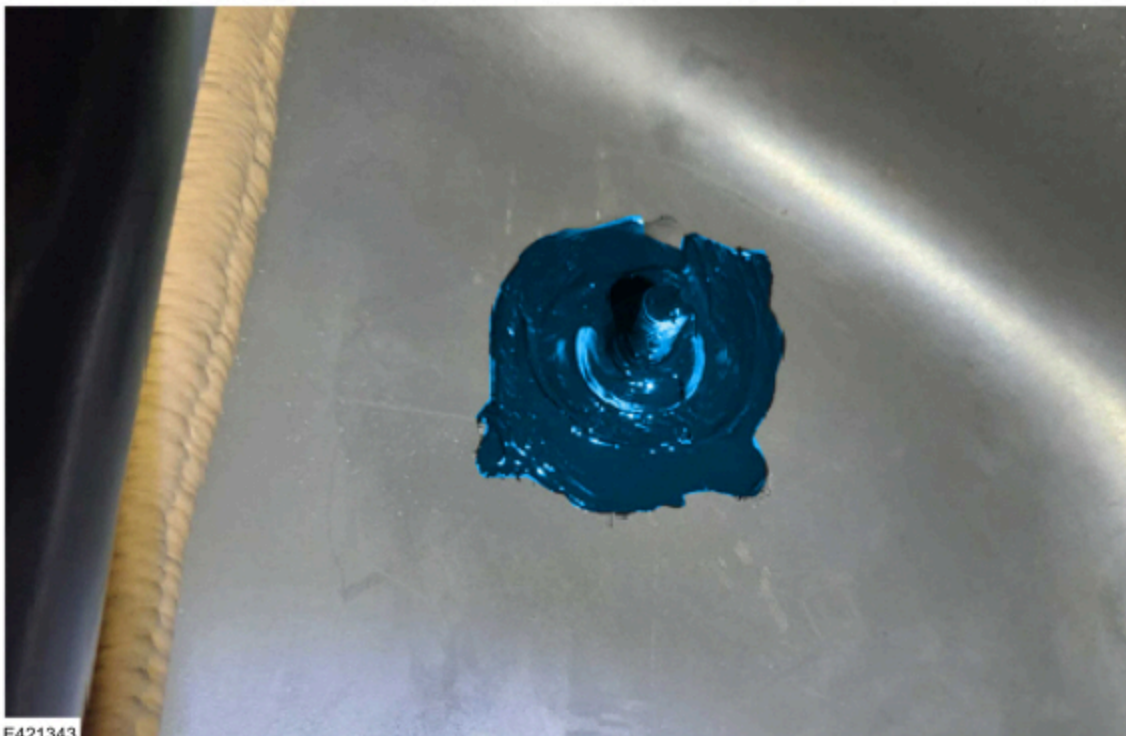
E421342

**⚠ CAUTION: Failure to properly seal the stud rivet could lead to water entry into the passenger area.**

23. Insert the stud rivet and secure using the stud rivet tool.

24. Spread the excess sealant around the rivet collar as well as the base of the stud to confirm adequate sealing. (Figure 13)

Figure 13



E421343

**NOTE: It is not necessary to wait for the sealant to dry before reassembly.**

25. Attach the hose retainer to the new stud.

26. Reassemble the right rear fender splash shield and secure using the retainers and locations shown in Figures 4-6.

**27.** Install the right rear wheel. Refer to WSM, Section 204-04A.

**28.** Refill the RDU. Refer to the WSM, Section 205-02.

**29.** Is the vehicle a 2021-2024 Bronco Sport?

(1). Yes - reprogram the AWD module using the latest software level of the FDRS scan tool. Repair is complete.

(2). No - repair is complete.

---

© 2026 Ford Motor Company

All rights reserved.

NOTE: The information in Technical Service Bulletins is intended for use by trained, professional technicians with the knowledge, tools, and equipment to do the job properly and safely. It informs these technicians of conditions that may occur on some vehicles, or provides information that could assist in proper vehicle service. The procedures should not be performed by "do-it-yourselfers". Do not assume that a condition described affects your car or truck. Contact a Ford or Lincoln dealership to determine whether the Bulletin applies to your vehicle. Warranty Policy and Extended Service Plan documentation determine Warranty and/or Extended Service Plan coverage unless stated otherwise in the TSB article. The information in this Technical Service Bulletin (TSB) was current at the time of printing. Ford Motor Company reserves the right to supersede this information with updates. The most recent information is available through Ford Motor Company's on-line technical resources.