



INSTRUCTION TO SERVICE

ITS: 61648		DATE 4/09/2026
SECTION:	260U – Battery System	
SUBJECT:	HV Roof Junction Box Connection Unused Stud Removal	
ISSUE:	Unused Junction Box Studs Coming Loose	
SUMMARY:	Remove Unused Junction Box Studs	

ITS61648

Ref. NHTSA Recall No.	Ref. Transport Canada Recall No.
Not Applicable	Not Applicable

THIS ITS DOCUMENT SHOULD BE RETAINED AND REFERRED TO FOR FUTURE MAINTENANCE UNTIL THE NEW FLYER PARTS AND/OR SERVICE MANUAL IS UPDATED TO REFLECT WORK DONE AS A RESULT OF THIS DOCUMENT. ENSURE THAT THIS DOCUMENT IS AVAILABLE FOR PARTS AND MAINTENANCE STAFF GOING FORWARD.

PROCEDURE:

Only trained personnel shall supervise and perform the High Voltage system testing, servicing and troubleshooting contained in this procedure.

1. Ensure to apply the parking brake.
2. Turn the master run switch to the off position and wait 5 minutes before proceeding.
3. Turn the 12/24V battery disconnect and HV Interlock switch to the “OFF” position.
4. Lock and tag the electrical system of the bus out and retain the key. See Figure 1.
5. Ensure to wear proper PPE.
6. Install a Lockout/Tagout Steering wheel cover as required.

☞ **NOTE:** Refer to the Lockout/Tagout Procedure in section 1 of your Preventive Maintenance Manual or section 9 of your Service Manual for additional information.

☞ **NOTE:** Use commercially available lock out equipment and tags being sure to follow any local laws or workplace procedures.

☞ **NOTE:** Refer to New Flyer High Voltage Safety Guidelines and Procedures Document 532295 (Appendix A) when completing installation or service work on high voltage power cables.

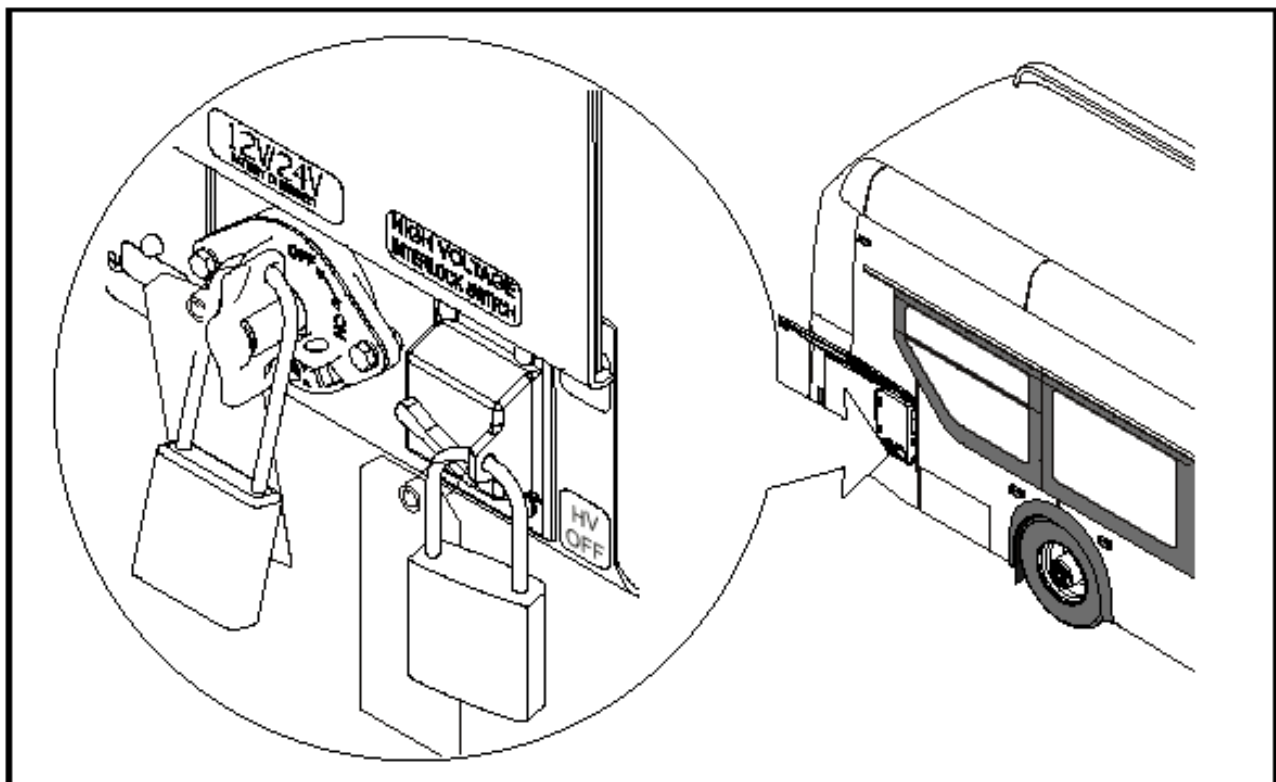

Figure 1: Lockout Tagout location reference.

7. Ensure no voltage is present before work begins. Using the appropriate fall protection, gain access to the upper street side of the bus and remove the hardware securing the side screen in place to gain access to the HV junction box. Set the side screen hardware aside for re-installation. See Figure 2.
8. Remove and set the junction box lid mounting hardware aside for re-installation and open the lid on the junction box. See Figure 2.
9. Locate the unused studs shown below and remove and discard them. See Figure 2.
10. Ensure all tools and debris are removed from inside the box and close and re-secure the lid with the original screws torquing them to 58 IN-LBS. See Figure 2.
11. Close and re-install the side screens.
12. Clean up all tools and debris and return bus to service condition.

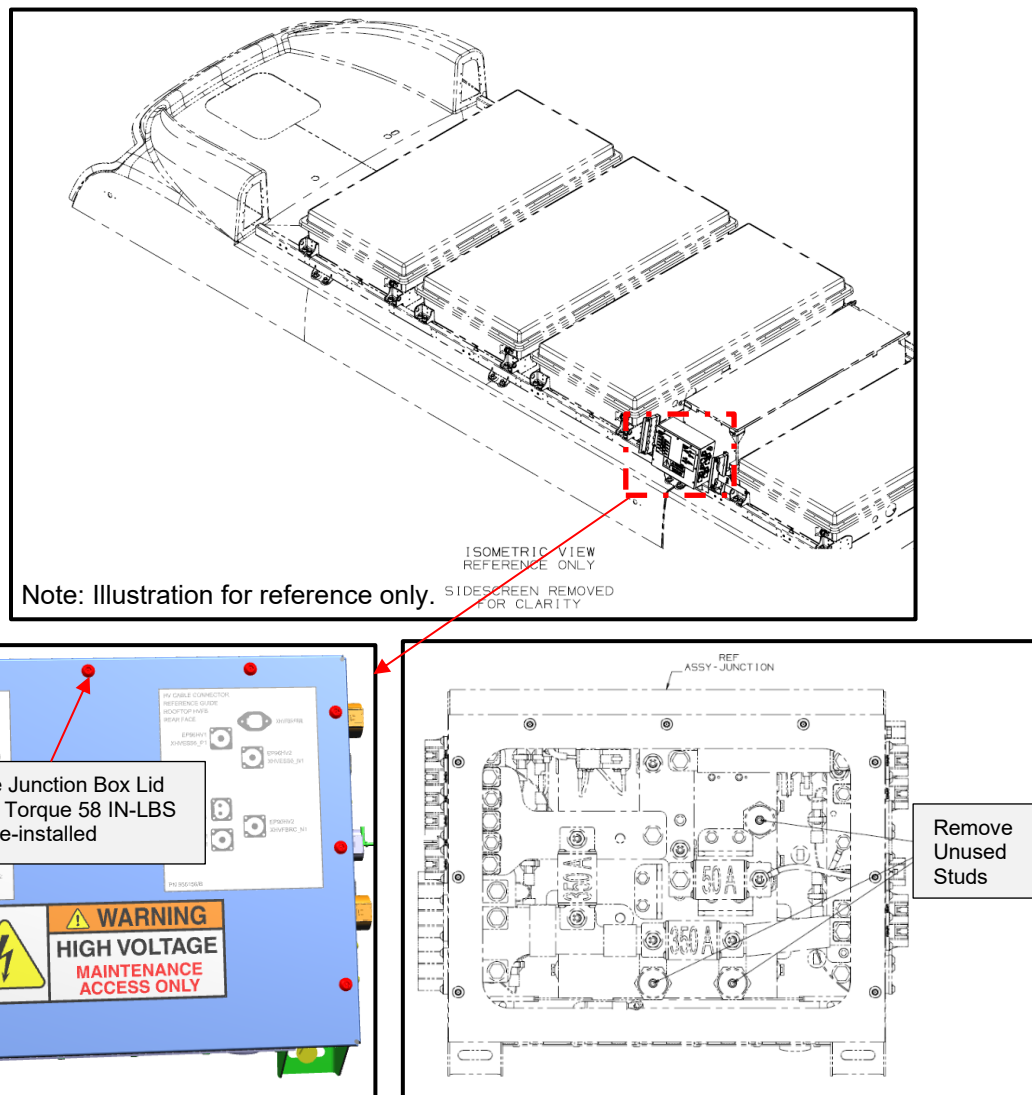

Figure 2: Street side upper junction box stud removal location reference.



LABOUR ESTIMATE				
	Operation	Number of Technician(s)	Hours	Labor Time T X HR
1	Remove Unused Junction Box Studs	2	.5	1

PARTS REQUIRED					
Item	Part Number	Description	Qty. per Coach	Units	Notes

SPECIAL TOOLS REQUIRED					
Item	Part Number	Description	Qty.	Units	Notes

Appendix A – NFIL Spec 532295 - High Voltage Safety Guidelines & Procedures for New Flyer Battery Bus

The following provides general guidelines in relation to safety and best practices when completing installation or servicing work on any New Flyer battery bus vehicle platform.

This document is not meant to supersede the actual released installation and assembly drawings and where conflicts arise, the released engineering drawings take precedence.

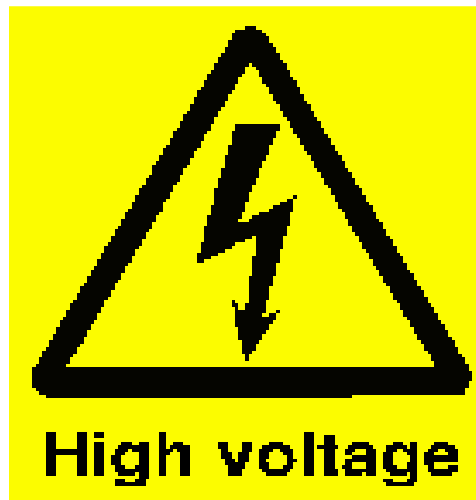

Introduction

The utmost concern, while working with High Voltage (HV) systems, is the safety of yourself, other personnel and the potential of damage to property. To minimize these risks, it is crucial to be properly trained and always maintain a very alert, questioning and disciplined attitude without fail. As soon as your guard is lowered, then the potential of an accident is probable that can hurt or kill yourself or someone else and possibly damage property.

What is High Voltage (HV)?

Any form of voltage that is greater than 50 volts if the person's skin at the electrical contact points is not compromised and not wet.

Equipment Required



The following equipment shall be required:

Digital Multimeter (DMM), 1000 volt Category II, 600 volt Category IV, 10Megohm impedance or greater with insulated case or rubber holster
Clamp-on current probe, 1000 volt Category II, 600 volt Category IV
High Pot Tester (Hi-Pot)
Phase rotation meter
Personal Protection Equipment (PPE) appropriate for 700volt DC & 230 volt AC with Class 00 or higher HV gloves with compatible leather over gloves. Appropriate safety glasses as well as the face shield. The PPE shall also meet the required Arc Flash & Arc Blast requirements. Before use, inspect the PPE in accordance with this guideline.
Adequate lighting
HV insulated mat
Two fused HV clip leads 10 inches long
Safety barricade with warning lights & "Danger High Voltage" signs
Belt tool pouch (use only to carry small components up/down a ladder)
Torque Screwdriver set
Imperial torque nut driver set
Metric torque nut driver set
Imperial 1/4" torque drive socket set
Imperial 3/8" torque drive socket set
Insulated rescue hook
ABC Fire extinguisher, 5 lb minimum, at the activity areas
Spare HV and low voltage fuses

Equipment Calibration

All test equipment must be within their calibration interval and recorded such with the respective serial numbers. These records must be available to the Checker.

Personnel Requirement

Only trained personnel shall supervise and perform High Voltage system testing, checkout and troubleshooting. Two personnel (one called the Checker & the other called Monitor/Recorder) shall perform Checkout Procedures, together, to ensure safety of themselves, others nearby & for the protection of vehicle & property. Refresher training shall be provided to these personnel on a regular basis and when new systems are to be checked by them. The training of the personnel shall consist of:

HV & low voltage basics, intermediate & advanced electricity
HV & low voltage electrical systems of the vehicle
Shop safety practices & procedures
First aide including CPR & the use of the shop defibrillator
How to release a victim that can't let go HV
Quickest method of shutting down HV



Fire fighting and emergency procedures
HV & arcfash safety
Organized & tidy placement of equipment & tools allowing for unrestricted movement
Operation of Hi-pot
Operation of Phase Rotation Meter

To ensure effectiveness of training, exams of the trained material shall be required with a high passing mark of at least 80% and a retraining of the missed 20 % on a one to one basis.

Checker Function

(Caution: The Checker must not have any health conditions that can be exacerbated when startled and must not have any electronic implants.)

Directed by the Monitor/Recorder
Performs all preparations & checks
Wears PPE as specified by the Checkout Procedure
Performs all restorations

Vehicle Inspection

It is necessary that the vehicle to be checked out, first be visually inspected of all systems, workmanship and with special attention to ensuring there is no HV cable or equipment damage or chafing.

High Voltage Checkout Preparation

- (1) The scope of the work must be accurately defined such as a Checkout Procedure that requires systematic steps with sign offs. Before a Checkout is performed, the Supervisor, Checker and Monitor/Recorder must conduct a briefing of what shall transpire, identify potential hazards, resist pressures of “is it done yet?”, anticipate problems and question possible events. If an unexpected electrical hazard or fault occurs, during any time of the Checkout, it must be immediately reported to the supervisor. After the Checkout is completed the same group should review the results and processes and make proposed modifications to the procedures if required.
- (2) Install Safety barricade with warning lights & signs indicating "Danger High Voltage" around the vehicle perimeter and ensure no personnel are within the fenced perimeter during the checkout procedure.
- (3) It shall always be the goal to check the systems as much as possible with all HV power OFF and Locked Out/Tagged Out and proven as de-energized by voltage measurement using the DMM. The functionality of the DMM must be proved before and after the verification of no HV present. Then, if possible, the HV systems should be challenged by trying to energize them while checking that no HV appears.
- (4) When it is necessary to perform tests of HV systems with the power ON, then the Working Live procedure must be followed.
- (5) The test personnel shall always rehearse the actions required in case of any possible accident scenarios.
- (6) Before beginning the Checkout Procedure, the test personnel shall remove all their jewelry (including pierced ones), watches and any electrically conductive objects on them.

PPE Requirements

The PPE voltage class, Arc Flash and Arc Blast rating shall be compatible with the voltage and Arc Flash capability of the systems being tested. Appropriate leather glove protectors shall be worn over the HV rubber gloves.

PPE Care & Testing

Rubber insulated PPE shall be periodically cleaned and tested in accordance with 29 CFR 1910.137 and the appropriate ANSI/ASTM standards. HV gloves, sleeves and mats shall be tested every 6 months. PPE apparel shall be cleaned and maintained in accordance with the manufacturer's instructions. A record of the PPE testing shall be maintained and available to the users.

PPE Inspection

Inspect PPE equipment, before use, for any degradation or damage and ensure that the HV gloves have been tested every 6 months. Also perform an air pressure test on the HV gloves before and after each use. If during PPE use a potential damaging incident occurred to the PPE, stop further testing and inspect the PPE. If at any time the PPE is defective, reject it, and obtain an accepted one.

PPE Storage

PPE apparel should be stored lying flat, undistorted, right-side out and not folded in protective containers. The HV mats can be rolled with an inside diameter greater than 2 inches.

Rubber HV gloves should be stored in cool, dark, dry, and free from damaging chemicals or vapors. The glove cuffs should face downwards, without folding, in the appropriate glove bag and hung vertically.

Insulated Tools

Insulated tools should be visually inspected for insulation damage before and after each session of use.

Lockout/Tagout Procedure

The Lockout/Tagout procedure should be followed that is specified in the respective Checkout procedure. When removing the lock and tag:

- (1) The locks and tags shall be removed by the installer of them or under her/his supervision.
- (2) If the installer of the locks and tags is not available, then her/his supervisor:
 - (a) Ensures that the installer of the locks and tags is not in the facility
 - (b) Contacts the installer to inform her/him that the locks and tags will be removed
 - (c) Reminds the installer of the lock and tag removal when she/he resumes work

Stored Energy

Personnel must always remember the characteristics of stored energy devices such as capacitors and batteries and when energy is available from.

Working Live

To maximize safety, it is always important to perform the maximum amount of HV checkout in the de-energized state.

When it is necessary to work with HV equipment while energized or to verify whether HV is present, the utmost care and safety procedures must be utilized including:

- (1) Wearing appropriate PPE with protector gloves over top of the HV rubber gloves
- (2) Ensure all personnel, except the Checker and Monitor/Recorder, are clear of the vehicle
- (3) Kneeling or standing on HV insulated mat

Energizing & De-energizing Procedure

It is critical that before any HV system is energized that a visual check be performed to ensure that all possible HV compartments are closed and there is no debris, tools or test equipment lying on HV terminations. If there is a certain sequence of energizing and de-energizing the HV system, then all personnel involved must be trained in this sequence. (**CAUTION:** Never try to connect or disconnect circuit components such as cables, fuses, connectors, etc while there is current flowing in the circuit.)

Electrical Injuries

Electrical injuries should be immediately reported to the first aid personnel and the supervisor. Other than electrostatic shocks, even non-injurious electrical shocks should be reported to the supervisor. These should be immediately investigated and documented to determine the cause and prevent the occurrence in the future.

Appendix B – NFIL PPE Categories

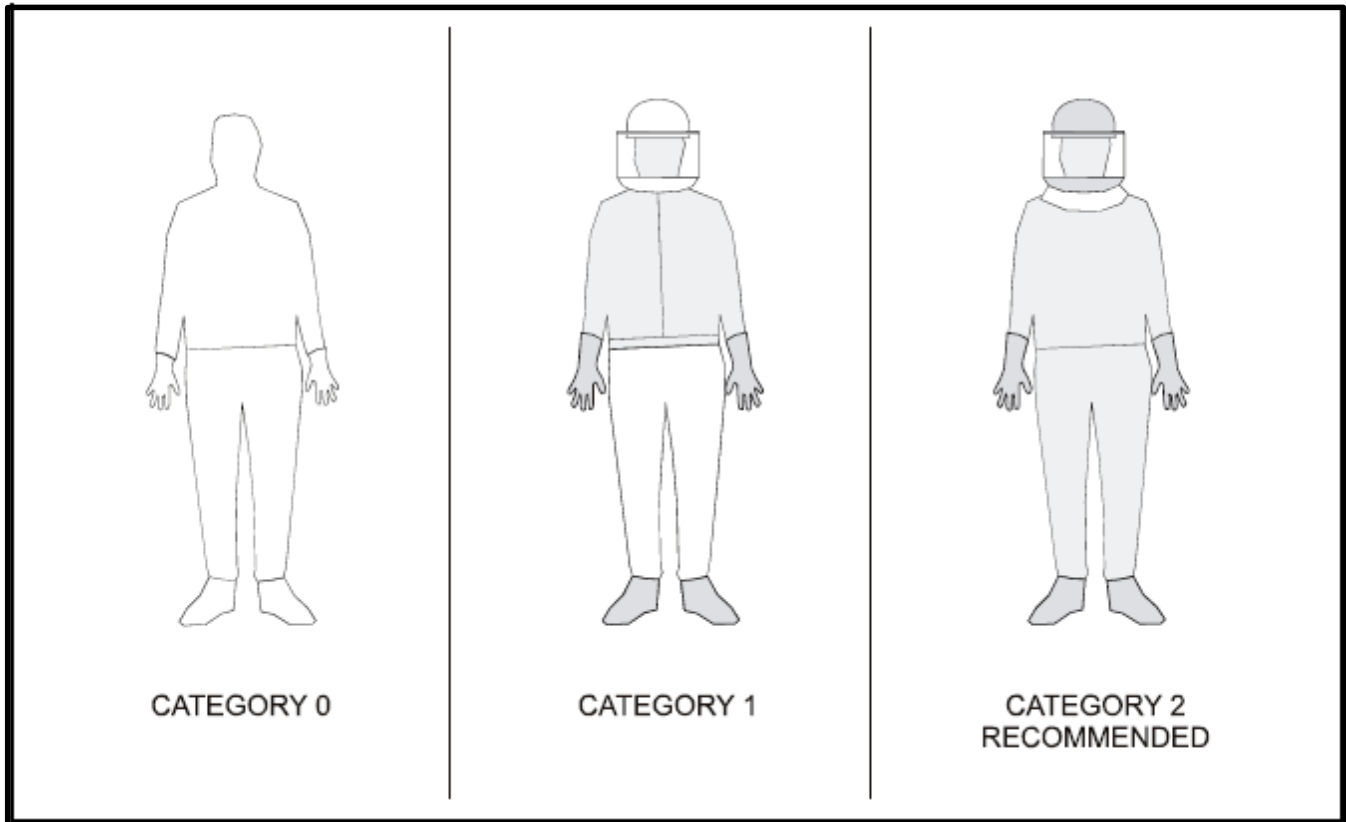



PPE CATEGORIES		
CATEGORY 0	CATEGORY 1	CATEGORY 2
1.2 cal/cm2	4 cal/cm2	8 cal/cm2
Arc Rated Clothing:		
Untreated cotton long sleeve shirt and pants	AR long sleeve shirt and pants or AR coverall	AR long sleeve shirt and pants or AR coverall
	AR flash suit hood or AR face shield	AR flash suit hood or AR face shield and AR balaclava
	AR jacket, parka, rainwear or hard hat liner (as needed)	AR jacket, parka, rainwear or hard hat liner (as needed)
Other Equipment:		
Hard hat	Hard hat	Hard hat
Safety glasses	Safety glasses or goggles	Safety glasses or goggles
Hearing protection	Hearing protection (with inserts)	Hearing protection (with inserts)
	Heavy duty leather gloves	Heavy duty leather gloves