



HYUNDAI
Technical Service Bulletin

GROUP	NUMBER
ENGINE ELECTRICAL	26-EE-003H
DATE	MODEL(S)
APRIL 2026	SEE BELOW

SUBJECT: STARTER FREEZING INSPECTION &
 STARTER MAGNETIC SWITCH (SOLENOID) REPLACEMENT

Description: Some vehicles may exhibit difficulty starting in cold weather. This bulletin provides the procedure to perform an inspection on the starter magnetic switch for potential freezing and, if necessary, replace the starter magnetic switch (solenoid) assembly.



Applicable Vehicles:

Model Year	Model
2018 – 2021	Elantra GT (PD)
2020 – 2023	Elantra (CN7)
2021 – 2023	Elantra (CN7A)
2018 – 2023	Kona (OS)
2024 – 2025	Kona (SX2)
2021 – 2023	Santa Fe (TMA)
2015 – 2019	Sonata (LFA)
2021 – 2023	Sonata (DN8)
2022 – 2024	Tucson (NX4, NX4A)
2019 – 2022	Veloster N (JS N)
2020 – 2024	Venue (QX)

Parts Information:

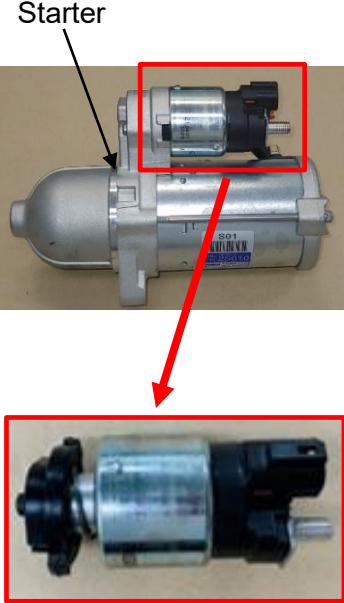
Model	Model Year	Engine	Type	Part Number		Figure		
				Starter Magnetic Switch Assy	Starter			
Elantra (CN7)	2020–2023	1.6T	N/ISG	36120-2M402QQH	36100-2M318	 <p>Starter</p> <p>Magnetic Switch Assembly</p>		
Kona (SX2)	2024–2025							
Venue (QX)	2020–2024							
Elantra (CN7, CN7A)	2020–2023	2.0 PE	N/ISG	36120-2J104QQH	36100-2J100			
Kona (SX2)	2024–2025				36100-2S000			
Sonata (DN8)	2021–2023	2.5	ISG	36120-2J304QQH	36100-2M417			
Kona (OS)	2021–2023	1.6T			36100-2J300			
Elantra (CN7, CN7A)	2020–2023	2.0			ISG		36120-2J304QQH	36100-2S010
Kona (OS)	2021–2023							
Kona (SX2)	2024–2025							
Santa Fe (TMA)	2021–2023	2.5			ISG	36120-2J304QQH	36100-2S010	
Sonata (DN8)								
Tucson (NX4, NX4A)	2022–2024							
Elantra GT (PD)	2018–2021	1.6			N/ISG	36120-2B513QQH	36100-2B510	
Sonata (LFA)	2014–2019							
Kona (OS)	2018–2020	1.6T	N/ISG	36120-2E202QQH	36100-2E200			
Elantra GT (PD)	2018–2021	2.0						
Kona (OS)	2018–2020							
Veloster N (JS N)	2019–2022	2.0T	ISG	36120-2G302QQH	36100-2G300			
Santa Fe (TMA)	2021–2023	2.0T / 2.4 PDEN						

Qty: 1 each

Warranty Information:

Model	Op. Code	Operation	Op. Time	Causal Part	Nature Code	Cause Code
All	36120F00	Starter Freezing Inspection	0.3 M/H	Refer to WebLTS for applicable part to labor Op Code combination	D93	ZZ6
Sonata (LFA)	36120F01	Starter Freezing Inspection & Starter Magnetic Switch (Solenoid) Replacement	0.9 M/H			
Elantra 1.6T (CN7) & Kona 1.6T (SX2)	36120F02		1.0 M/H			
Elantra GT 1.6 (PD)						
Kona 1.6T (OS)						
Elantra 2.0 (CN7, CN7A)	36120F03		1.1 M/H			
Elantra GT 2.0 (PD) Kona 2.0 (OS)						
Kona 2.0 (OS, SX2)						
Sonata (DN8)						
Veloster N (JSN)						
Venue (QX)						
Santa Fe (TMA)	36120F04		1.2 M/H			
Tucson (NX4, NX4A)						

NOTE 1: Normal warranty applies.

NOTE 2: Submit claim on Claim Entry Screen as “Warranty” type.

NOTE 3: Take a picture of the warrantable defect. Op times include VIN, mileage, and repair justification photo(s) as outlined in the Digital Documentation Policy.

NOTE 4: The incident parts are subject to callback through the normal Warranty Technical Center (WTC) parts return process. **Claim is subject to debit if the part is not returned.**

NOTE 5: If a part is found in need of replacement while performing this TSB and the affected part is still under warranty, submit a separate claim using the same repair order. If the affected part is out of warranty, submit a Prior Approval request for goodwill consideration prior to performing the work.

Service Procedure:**DIGITAL DOCUMENTATION**

This TSB includes repair justification photos. Refer to the latest Warranty Digital Documentation Policy for requirements.

NOTICE

Applying the recommended torque to all fasteners is essential to reduce potential issues from occurring after the service procedure.



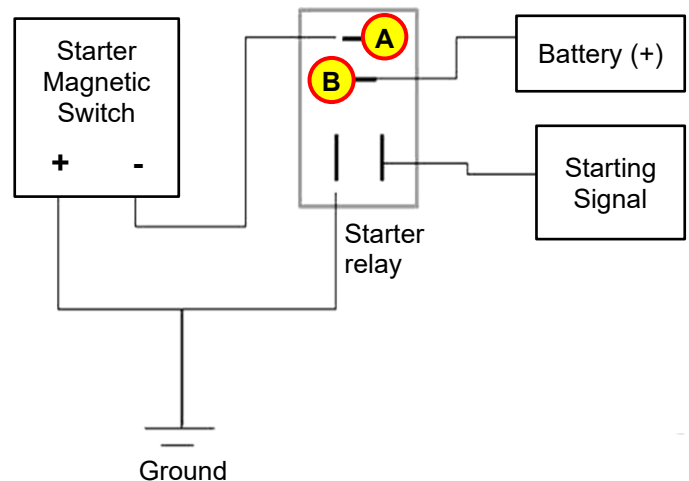

Starter Freezing Inspection

Be sure to perform the inspection in cold ambient temperatures (such as outdoors, away from sunlight) as soon as possible when the symptom is noticed. The symptom may disappear when ambient temperatures increase.

1. Verify that the starter is frozen even when a cranking attempt is made by starting the vehicle via key/button. (The starter is not frozen if the engine is rotating or buzzing even slightly.) If dashboard/interior lights blink or dim during startup attempt, this means the battery is discharged. Please recharge and repeat step 1 above.
2. Remove the starter relay from the relay box.
3. Bridge the connection across (A) and (B) terminals for 1 to 2 seconds to confirm if the starter motor runs.
4. Check whether the starter is frozen.
 - If the engine rotates slowly or if a buzzing sound is heard from the starter.
 - This is not a freezing problem.
Check for other causes of failure.
 - If the dashboard/interior lights flicker or dim during the start attempt.
 - This is most likely a discharge issue, rather than freezing.
Continue to next step.
 - If there is no starter operation, no engine movement and no other electrical fluctuations.
 - This is most likely a frozen starter.
Continue to next step.
5. Start the vehicle by connecting a jumper pack to the battery terminals.
 - If the engine starts normally, check whether the vehicle battery is abnormal.
 - If the engine does **NOT** start normally, proceed to the next section, [Starter Magnetic Switch Replacement](#).



Starter Identification

	Starter	Starter Magnetic Switch
Location		
Lot Number		
Lot Number Identification (example only)	<ul style="list-style-type: none"> • 230131: Date (Year/Month/Day) • 0936: Time (Hour/Minute) • 0500: Serial (4 digit) • LKS1: Final inspector 	<ul style="list-style-type: none"> • 230116: Date (Year/Month/Day) • 2590: Serial (4 digit)

Starter Magnetic Switch Replacement

1. Remove the starter magnetic switch assembly (A) by referring to the shop manual:
 - **Engine Electrical System > Starting System > Starter > Repair procedures**

i Information

Elantra (CN7A) shown for example only.

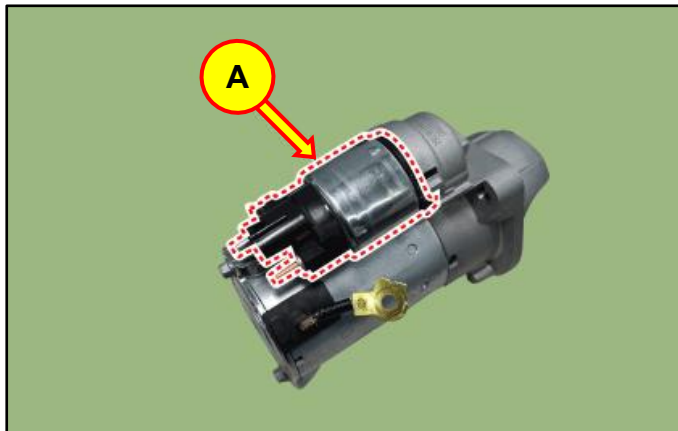

2. Install the new starter magnetic switch assembly.

i Information

Refer to the model-specific torque specs in the [Torque Specifications](#) section starting on **page 8**.

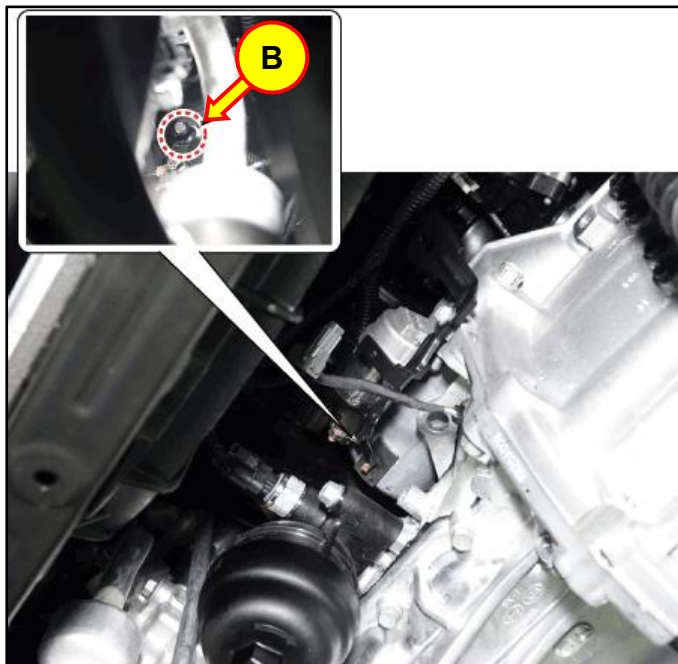

- Starter "B" Terminal Mounting Nut (B)

- Starter Mounting Bolt (C):

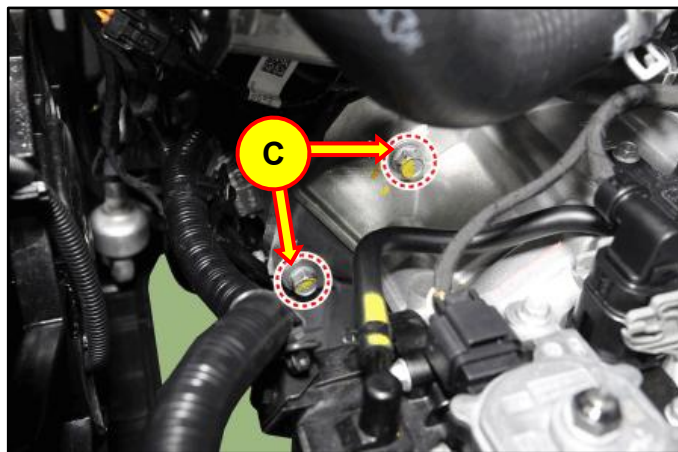

3.

**DIGITAL
DOCUMENTATION**



Using the STUI camera function, take a photo of the original starter magnetic switch assembly with the lot code clearly visible.

Upload the photo to STUI.

NOTE: If the STUI camera function is **NOT** used, write the last 6 digits of the VIN and date of repair on a piece of paper to include in the photo.



4. Reinstall all parts in the reverse order of the removal process.
5. Start the vehicle and verify proper operation.
6. The service procedure is now complete.

Torque Specifications

Elantra (CN7/CN7A):

Starter "B" Terminal Mounting Nut:

lb-ft	16
-------	----

N.m	22
-----	----

Starter Mounting Bolt:

lb-ft	42
-------	----

N.m	57
-----	----

Elantra GT (PD):

Starter "B" Terminal Mounting Nut:

lb-ft	8.0
-------	-----

N.m	22
-----	----

Starter Mounting Bolt:

lb-ft	42
-------	----

N.m	57
-----	----

Kona (OS, Gamma2, Nu PE):

Starter "B" Terminal Mounting Nut:

lb-ft	8.0
-------	-----

lb-in	95
-------	----

N.m	11
-----	----

Starter Mounting Bolt:

lb-ft	42
-------	----

N.m	56
-----	----

Kona (SX2):

Starter "B" Terminal Mounting Nut:

lb-ft	8.0
-------	-----

lb-in	95
-------	----

N.m	11
-----	----

Starter Mounting Bolt:

lb-ft	42
-------	----

N.m	56
-----	----

Santa Fe (TMA):

Starter "B" Terminal Mounting Nut:

lb-ft	8.0
-------	-----

lb-in	95
-------	----

N.m	11
-----	----

Starter Mounting Bolt:

lb-ft	42
-------	----

N.m	56
-----	----

Sonata (DN8):

Starter "B" Terminal Mounting Nut:

lb-ft	8.0
-------	-----

lb-in	95
-------	----

N.m	11
-----	----

Starter Mounting Bolt:

lb-ft	42
-------	----

N.m	56
-----	----

Sonata (LFA):**Starter "B" Terminal Mounting Nut:**

lb-ft	8.0
lb-in	95
N.m	11

Starter Mounting Bolt:

lb-ft	42
N.m	56

Tucson (NX4/NX4A):**Starter "B" Terminal Mounting Nut:**

lb-ft	8.0
lb-in	95
N.m	11

Starter Mounting Bolt:

lb-ft	42
N.m	56

Veloster N (JS N):**Starter "B" Terminal Mounting Nut:**

lb-ft	8.0
lb-in	95
N.m	11

Starter Mounting Bolt:

lb-ft	42
N.m	56

Venue (QX):**Starter "B" Terminal Mounting Nut:**

lb-ft	10
lb-in	124
N.m	14

Starter Mounting Bolt:

lb-ft	42
N.m	56