



Countries: Document ID: IK2200166  
 Availability: ISIS, FleetISIS, NotSIR Revision: 1  
 Major System: BUS BODY Created: 4/14/2025  
 Current Language: English Last Modified: 3/31/2026  
 Other Languages: NONE Author: Aaron Aguilera  
 Viewed: 168

[Less Info](#)

Hide Details

Coding Information

Copy Link 	Copy Relative Link 	Bookmark  <a href="#">View My Bookmarks</a>	Add to Favorites 	Print 	Provide Feedback 	Helpful  1	Not Helpful  0
---------------	------------------------	---	----------------------	-----------	----------------------	------------------	----------------------

Title: Next Gen Bus Heated Fuel Water Separator Retrofit

Applies To: Next Gen Bus

## CHANGE LOG

Please refer to the change log text box below for recent changes to this article:

04/22/2025 - Initial Article Release

## DESCRIPTION

This document will instruct the user on installing and programming a fuel water separator heater system for a Next Gen Bus built without the heater option.

## SYMPTOM(s)

Diagnostic Trouble Code(s) & Dashboard Indicator Light(s):

DTC/Light	Description
N/A	Not Applicable

Customer Observations or Concerns:

The customer may observe fuel gelling in cold conditions.

## SPECIAL TOOL(s) / SOFTWARE

Tool Description	Tool Number	Comments	Instructions
------------------	-------------	----------	--------------

Suitable Drain Pan	Not Applicable		
EZTech	Not Applicable	See IK2900030 for the current available models.	

---

## **SERVICE PARTS INFORMATION**

Kit Description	Part Number	Quantity Required	Notes
Bowl Assembly, Fuel Filter	1876530C92	1	
MM, IP, Fuel Water Separator Heater	6729075F93	1	
MM, Harness, FWS Racor Heater	6731701F95	1	

---

## **DIAGNOSTIC STEP(S)**

Not Applicable.

---

## **REPAIR STEP(S)**

**WARNING!** To prevent property damage, personal injury, and / or death, park vehicle on a hard, flat surface, turn the engine off, set the parking brake, and install wheel chocks to prevent the vehicle from moving in either direction.

**WARNING!** To prevent property damage, personal injury, and / or death, if the vehicle must be raised, do not work under the vehicle supported only by jacks. Jacks can slip or fall over.

**WARNING!** To prevent personal injury and / or death, always wear safe eye protection when performing vehicle maintenance.

**WARNING!** To prevent property damage, personal injury, and / or death, keep flames or sparks away from vehicle and do not smoke while servicing the vehicle's batteries. Batteries expel explosive gases.

**WARNING!** To prevent property damage, personal injury, and / or death, remove the ground cable from the negative terminal of the battery box before disconnecting any electrical components. Always connect the ground cable last.

**INSTALLING HEATED FUEL BOWL:**

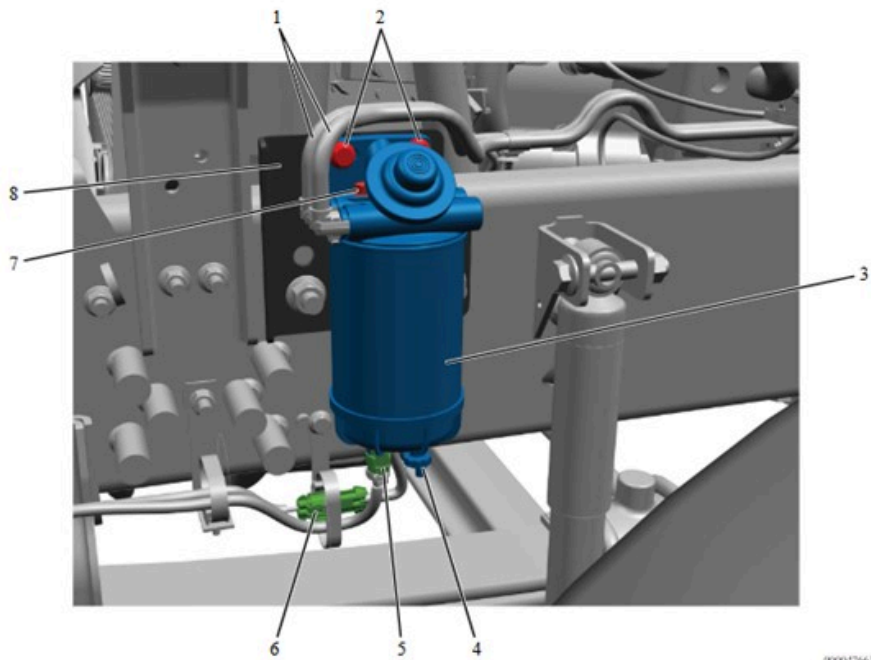

**Figure: Fuel / Water Separator Assembly**

1. Fuel line (2)
2. Mounting bolt and nut (2)
3. Fuel / water separator
4. Drain valve
5. Water In Fuel (WIF) sensor connector
6. Fuel heater connector
7. Vent plug
8. Mounting bracket

1. Place a suitable drain pan underneath the fuel/water separator (3).
2. Loosen the vent plug (7), and open the drain valve (4) to drain fuel from the fuel/water separator (3).
3. Close the vent plug (7).
4. Close the Drain Valve (4).
5. Disconnect the Water In Fuel (WIF) sensor connector (5).

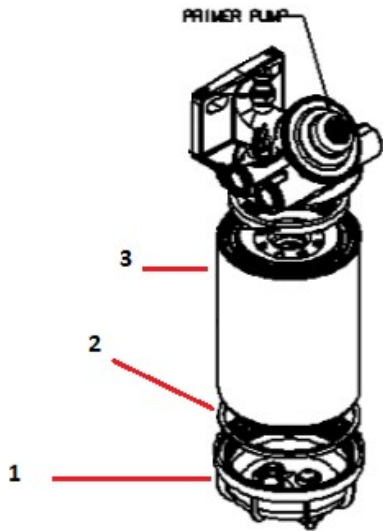

- 1. Bowl Assembly
- 2. Bowl O-ring
- 3. Fuel Element

6. Remove the lower bowl assembly (1) by unthreading from the fuel element (3).

7. Using PN:1876530C92, lubricate the O-ring with fuel and install the new lower bowl assembly with the heater element.

**PRIMING:**

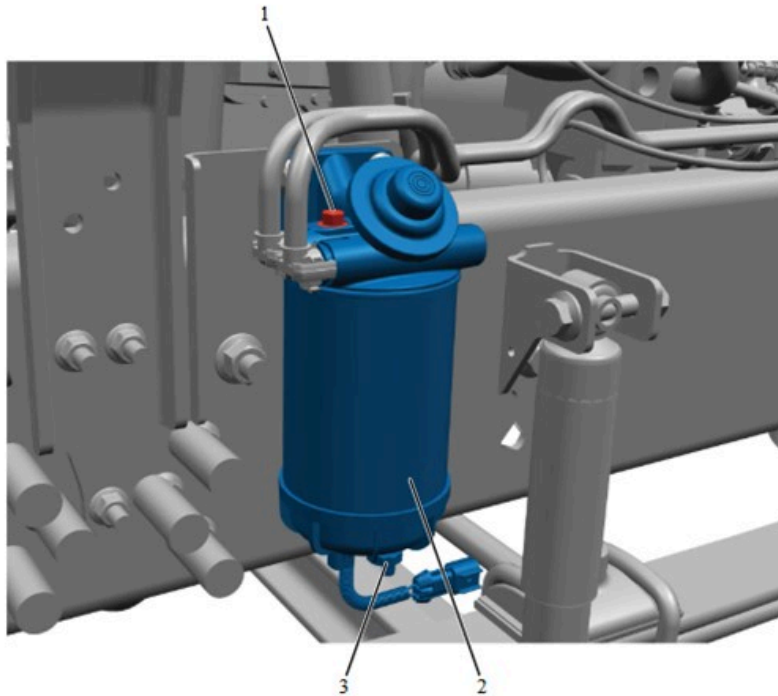

0000476657

- 1. Fill port plug
- 2. Fuel / water separator
- 3. Drain valve

1. Place a suitable drain pan underneath the fuel/water separator (2).

2. Open the drain valve (3) and drain oil.

3. Close the drain valve (3).

4. Remove the fill port plug (1) from the fuel/water separator (2).

5. Using clean fuel, fill the fuel/water separator (2) to the top of the filter.
6. Allow air to escape and wait until no air is visible in the fuel.
7. Install the fill port plug (1) on the fuel/water separator (2) and torque 80 lb-in (9 Nm)
8. Verify all connections are tight.
9. Key ON, Engine RUNNING (KOER), run for 1 minute.
10. Inspect for leaks while the engine is running.
11. Key OFF.

**FUEL HEATER WIRING:**

1. Disconnect the battery.
2. Remove the D1601 J4 Connector from the BCM, shown below.

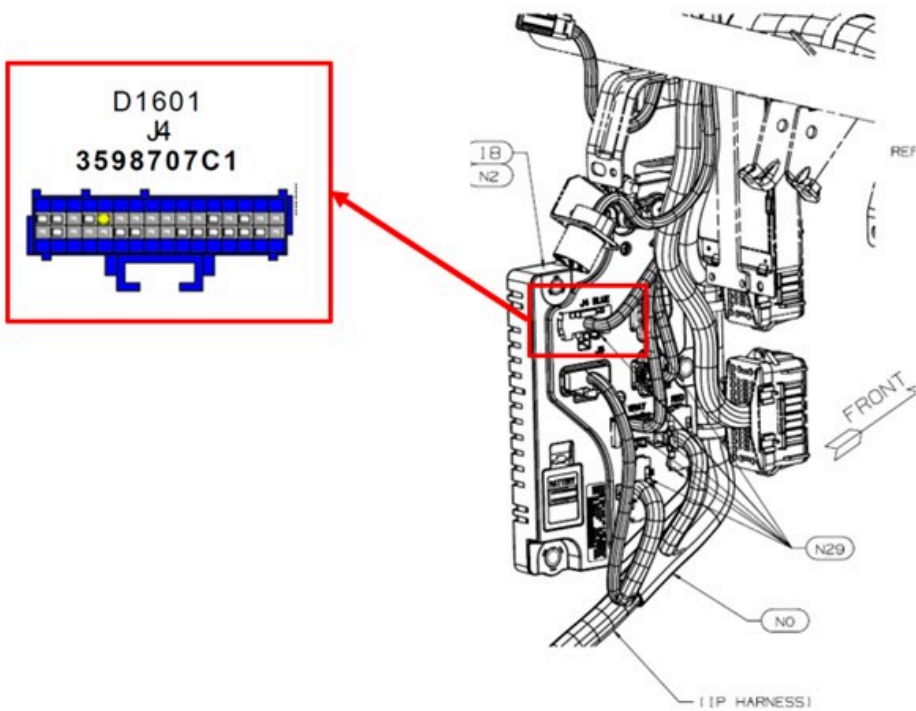

3. Using harness PN: 6729075F93, add wire A04-160-ABA (GY TXL) in cavity F12 shown below.

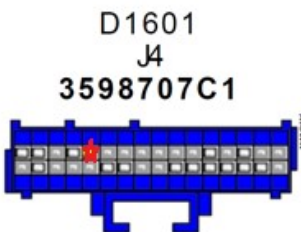

4. Reinstall the D1601 J4 connector into BCM.
5. Disconnect the D436B IP/Forward Chassis Connector shown below.

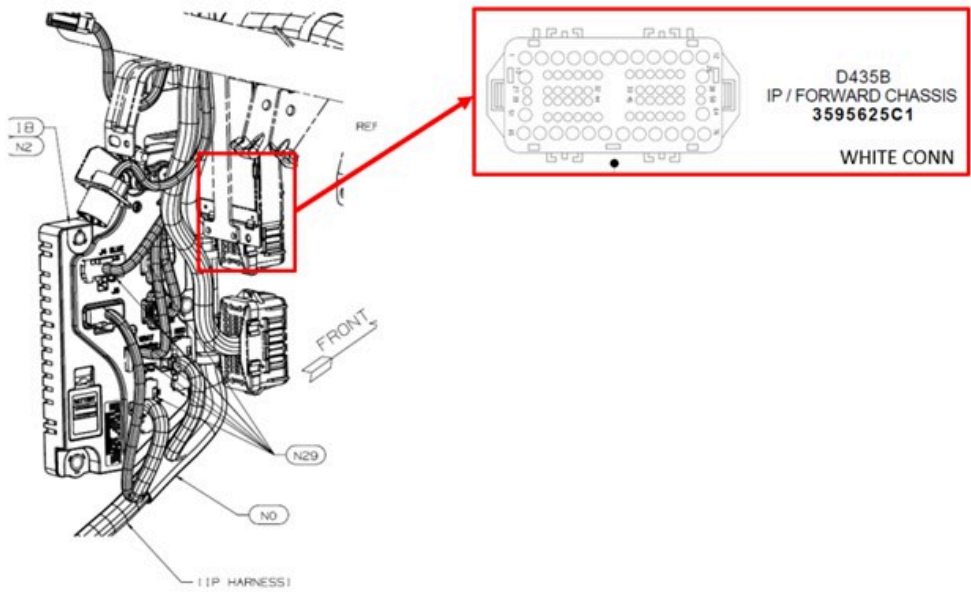

6. Add wire A04-160-ABA (GY TXL) in cavity 73 as shown below.

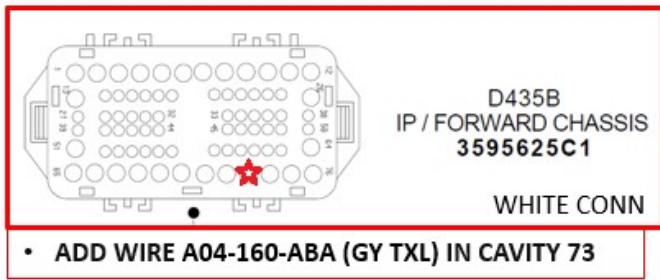

7. Reinstall the D435B connector.

8. Following the images below, route and secure the 6729075F93 harness wires into the IP harness using tape or straps.

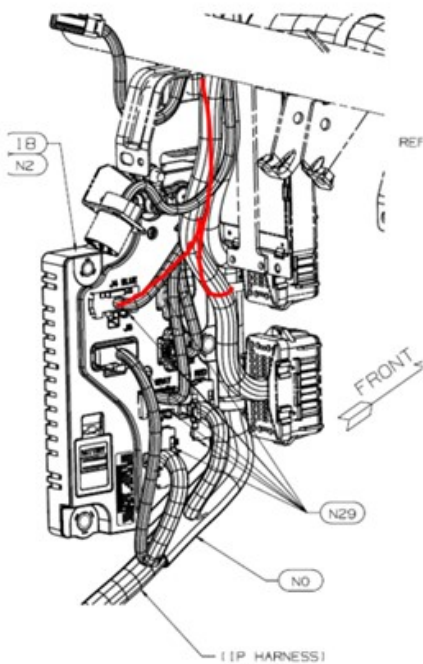

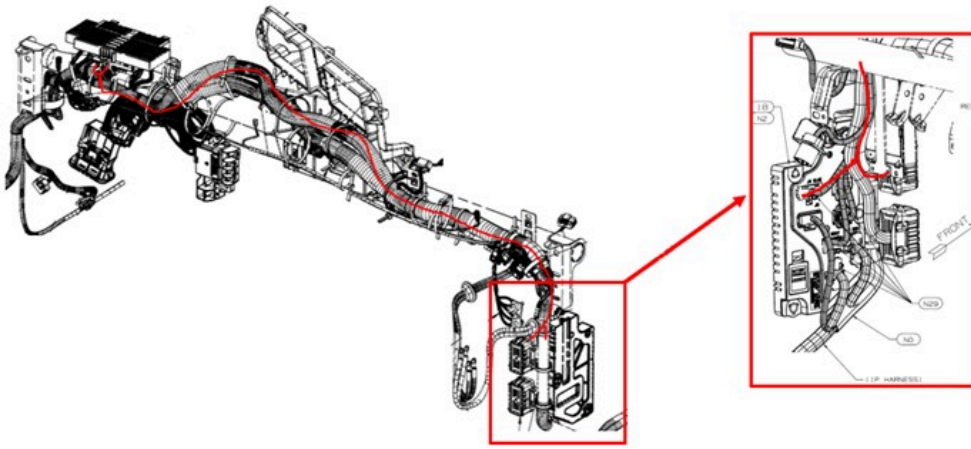

9. Disconnect ground adapter D1031 shown below.

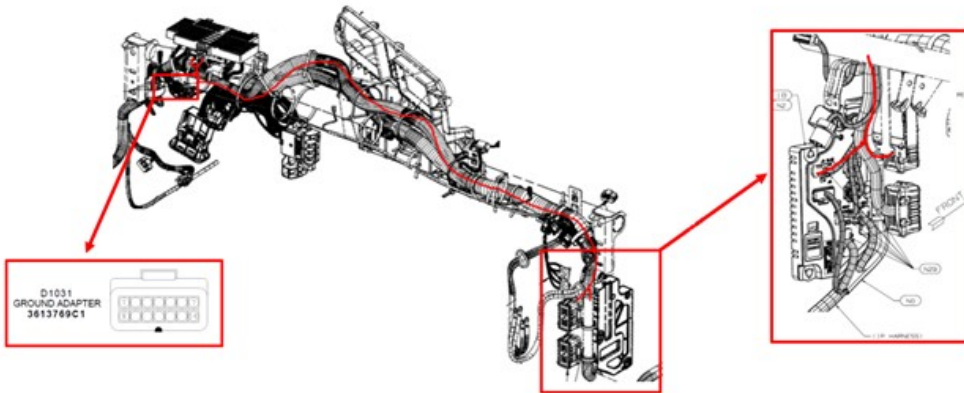

10. Add wire A04-011-ARA (WH TXL) in cavity 4 shown below.



11. Reconnect the D1031 ground adapter.

12. On the fuse panel, locate D1011 B2, as shown below.



13. Add wire A04-011-ARA (WH TXL) in cavity R6-85 shown below.

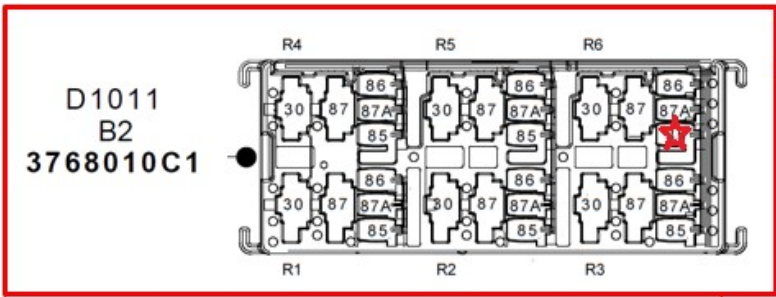

- ADD WIRE A04-011-ARA (WH TXL) IN CAVITY R6-85

14. Add wire A04-014-AGA (RD TXL) in cavity R6-30 shown below.

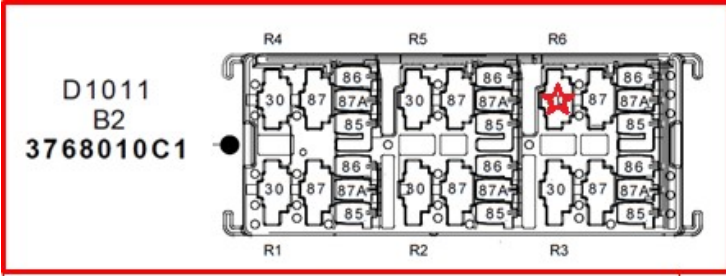

- ADD WIRE A04-014-AGA (RD TXL) IN CAVITY R6-30

15. Add wire A04-160-ABA (GY TXL) in cavity R6-86 shown below.

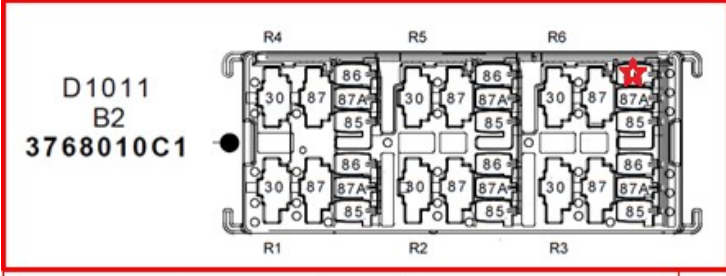

- ADD WIRE A04-160-ABA (GY TXL) IN CAVITY R6-86

16. Add wire A04-160-ACA (GY TXL) in cavity R6-87 shown below.

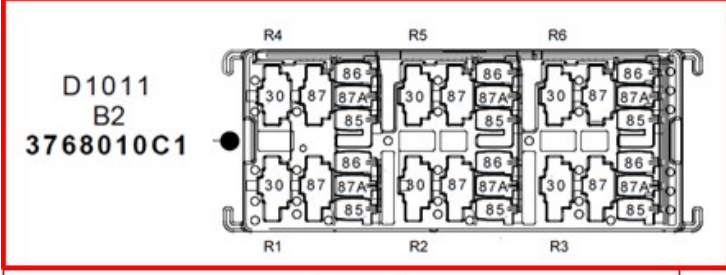

- ADD WIRE A04-160-ACA (GY TXL) IN CAVITY R6-87

17. Install the relay in position B2-R6 shown below.

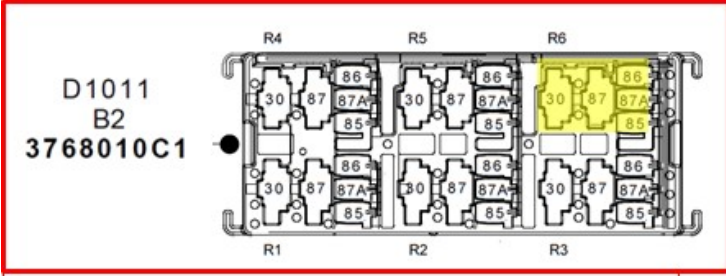

- ADD RELAY IN POSITION B2-R6

18. On fuse panel, locate 1017 B8 shown below.

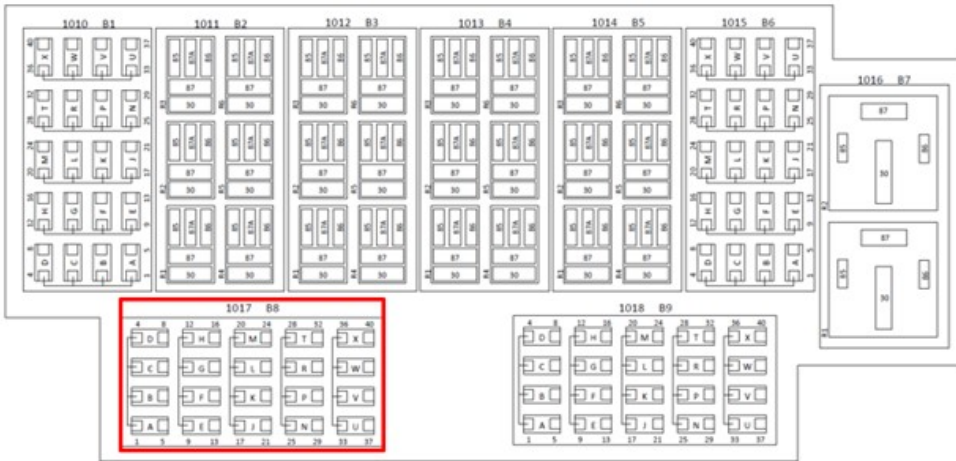

19. Add wire A04-014-AGA (RD TXL) in "J" cavity 21 shown below.

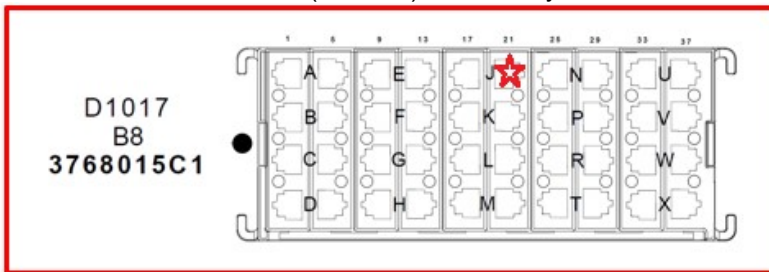

20. Install a 20A fuse in position J.

21. Under the hood, locate the forward chassis harness connectors at the firewall shown below.

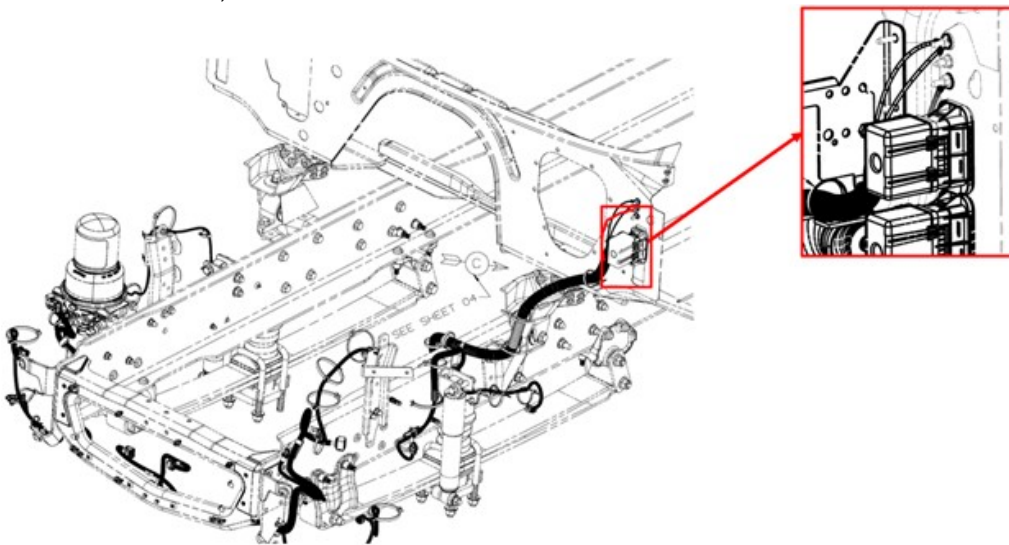

22. Disconnect the D435A IP/Forward Chassis Connector

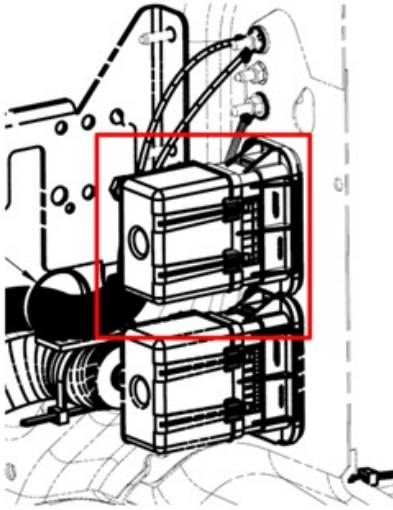

23. Add wire M04-160-ACA (GY TXL) in cavity 73 shown below.

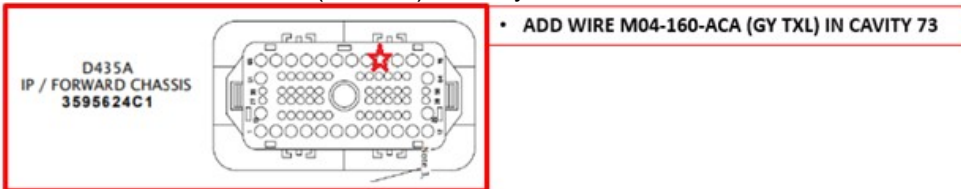

24. Reconnect D435A IP/Forward Chassis Connector.

25. Install ring terminal wire M04-010-EAA (WH TXL) onto D6002 ground post as shown below.

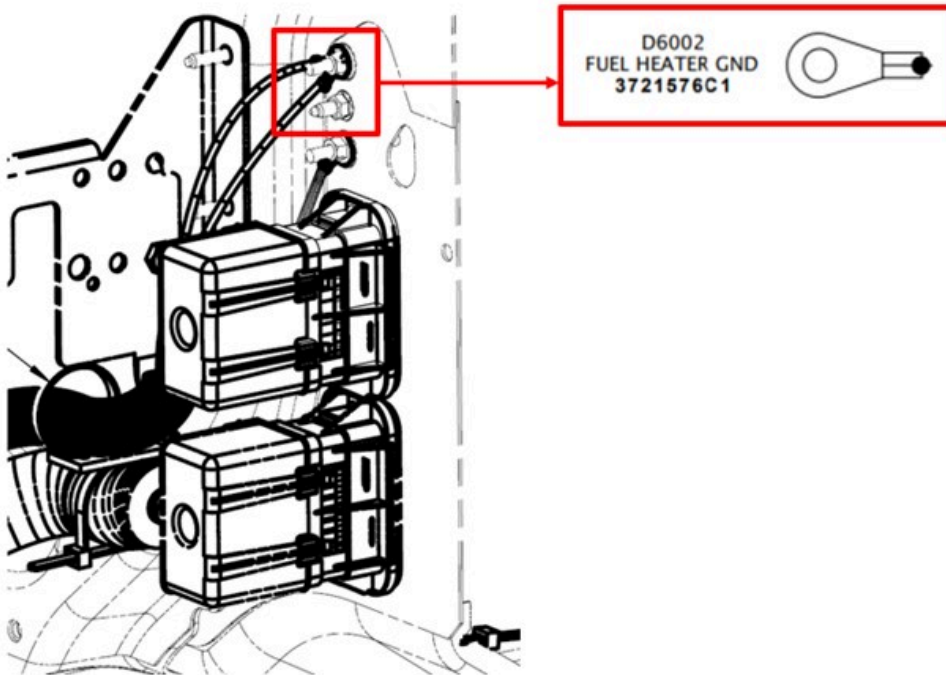

26. Route and secure the heater harness PN: 6731701X95 to the IP harness using tape or straps as shown below.

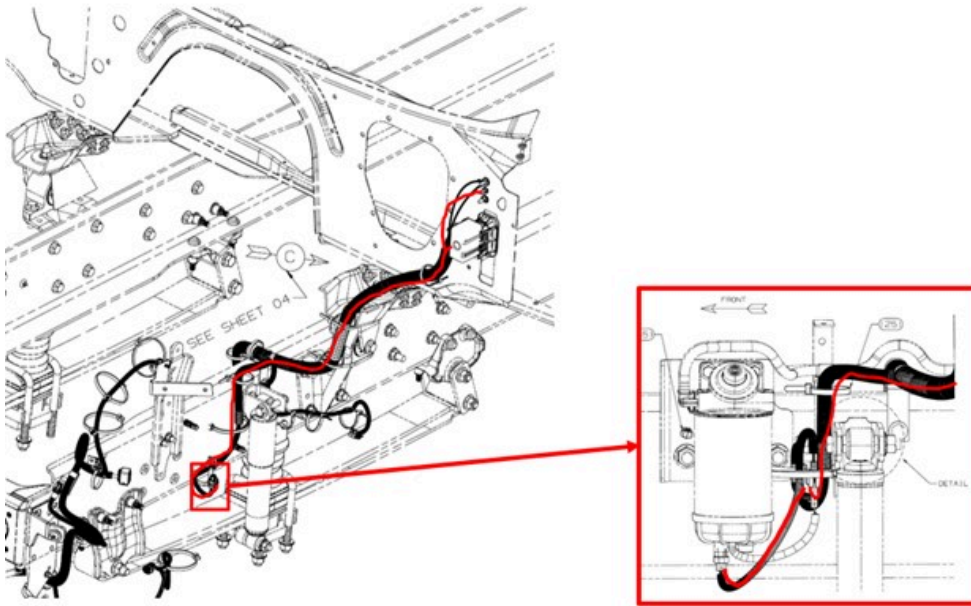

27. Connect D6014 to the fuel/water separator heater connector as shown.

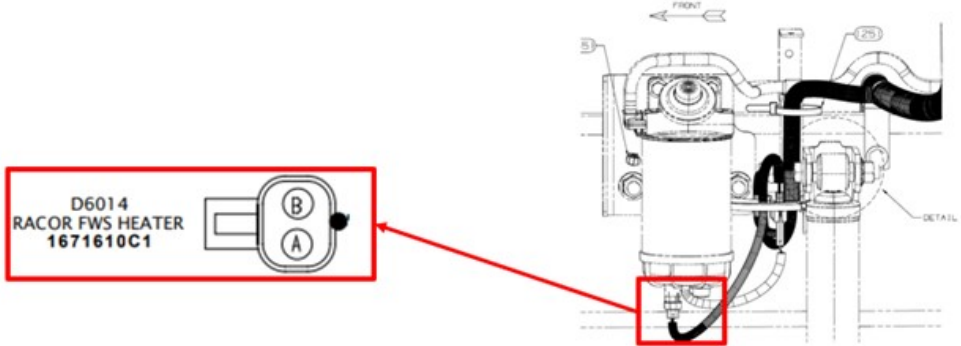

## DIAMOND LOGIC BUILDER PROGRAMMING:

1. Using Diamond Logic Builder, add feature 0597130 BCM Prog, Fuel Heater.

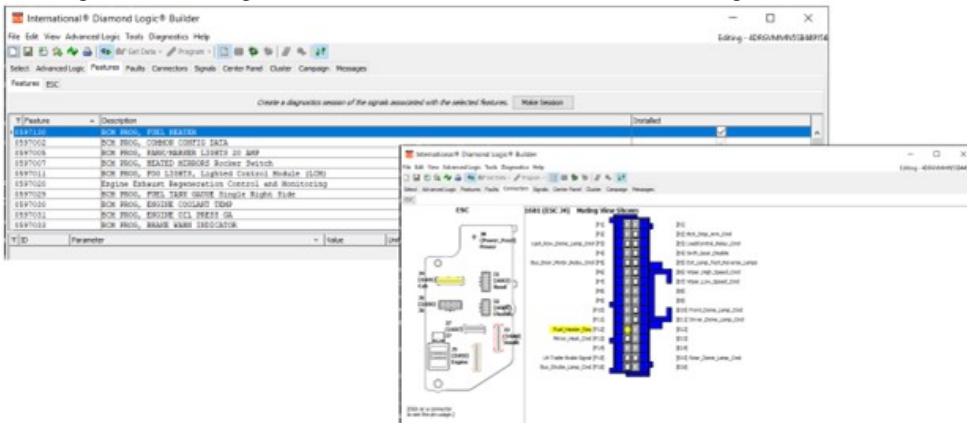

## WARRANTY INFORMATION

### Warranty Claim Coding:

Refer to the [Warranty Coding Manual](#) for Group and Noun Codes.

## Standard Repair Time(s):

Refer to the [SRT Manual](#) for Repair Times

---

## OTHER RESOURCES

[Master Service Information Site](#)

 Hide Details

### Feedback Information

Viewed: 167

Helpful: 1

Not Helpful: 0

No Feedback Found