

Vehicle Cannot be Charged and Fault Memory Entry for the Additional Coolant Pump in the High-Voltage Battery Control Unit (120/25)

Change Overview:

Revision	Date	Change
0	03/16/2026	▪ First Publication
1	03/30/2026	▪ Update to Work Procedure, Preparatory work

Model Year: **As of 2024 up to 2026**

Model Line: **Panamera (YAA / YAB)**

Equipment: Hybrid drive system PHEV (M-No. 0K3)

Concerns: **High-voltage battery**

Cause: **The customer complains that the vehicle can no longer be charged or the malfunction indicator light is active.**

A pin of the high-voltage battery control unit (BECM) can be loosened; therefore, the activation of the additional coolant pump for the low-temperature system (P2) is not possible. This results in potentially insufficient cooling during the charging process, which is why it is aborted or not started.

The following fault memory entry is stored in the fault memory of the high-voltage battery control unit (BECM):

- **POC4700** - additional coolant pump, activation, open circuit (00500A)

Action: Check activation of the additional coolant pump for low-temperature system (P2) and replace the high-voltage battery if necessary.



Information

The minimum requirement for troubleshooting is the Porsche Tester software release **43.900.000** (or higher).

Installation

Position:

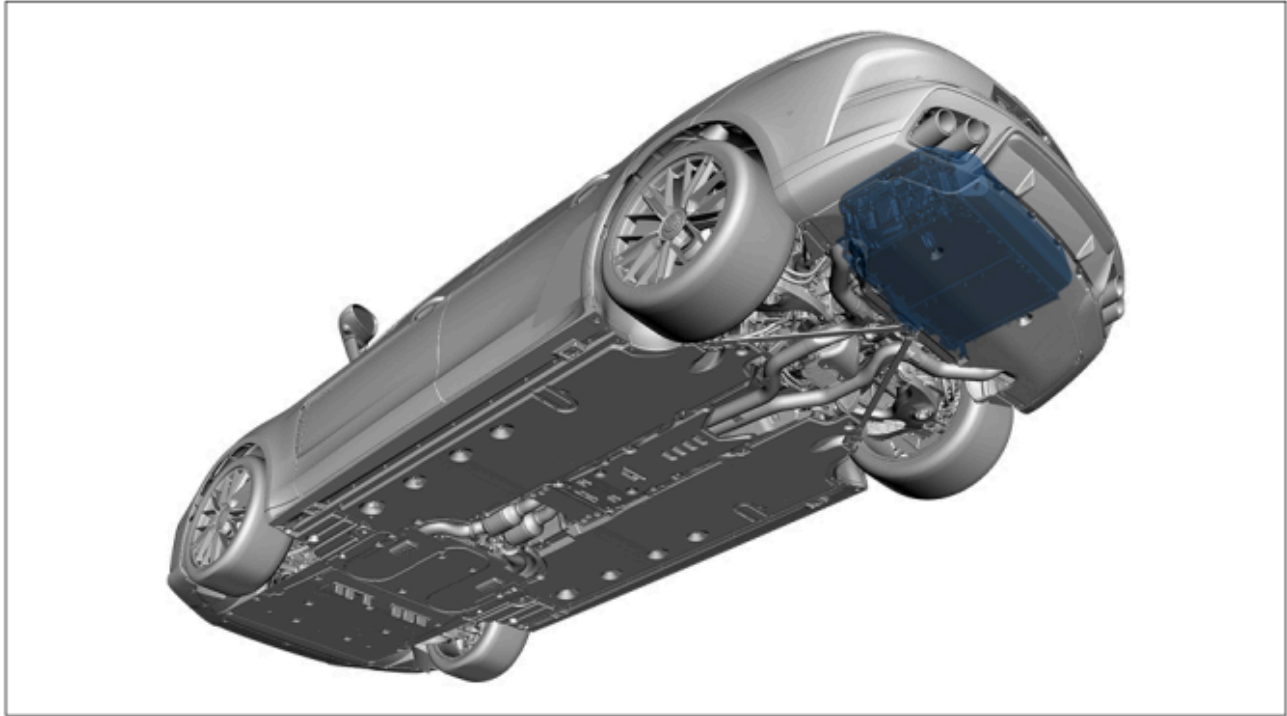

Installation position of high-voltage battery

Required tools

Tools:

- **P90999 - Porsche Tester 4**
- Battery charger with a current rating of **at least 90 A** and a **current and voltage-controlled charge map** for lithium starter batteries, e.g. **VAS 5908 - battery charger 90 A**. For further information about the battery chargers to be used, see the corresponding Workshop Manual. ⇒ *Workshop Manual '270689 Charge the battery and vehicle electrical system'*

Additional required tools for checking the signal line for the additional coolant pump for the low-temperature system (P2):

- Commercially available multimeter, e. g. **V.A.G 1526E - hand-held multimeter**
- **VAS 6931A - Transmission and engine jack**
- **VAS 6760A - Storage tray**
- Torque wrench 40-200 Nm (30-248 ftlb.), e. g. **V.A.G 1332A - Torque wrench, 40-200 Nm (30-248 ftlb.)**
- Torque wrench, 2-10 Nm (2-8 ftlb.), e.g., **V.A.G 1783 - Torque wrench, 2-10 Nm (2-8 ftlb.)**
- Torque wrench, 0.4-2 Nm (0.3-1.5 ftlb.), e. g. **VAS 6253A - Torque wrench, 0.4-2 Nm (0.3-1.5 ftlb.)**
- Torque wrench, 6-50 Nm (4.5-37 ftlb.), e. g. **V.A.G 1331A - Torque wrench, 6-50 Nm (4.5-37 ftlb.)**

Additional required tools for checking the signal line for the additional coolant pump for low-temperature system (P2) [only for vehicles with central wheel lock (M-no.: 1PJ):

- **9794 - Assembly aid**
- **VAS 6266A - Wheel fitting trolley**
- **Torque wrench 150-600 Nm (111-443 ftlb.), e. g. V.A.G 1601 - Torque wrench 150-800 Nm (111-590 ftlb.)**

Additional required tools for replacing the high-voltage battery:

- **P90076 - Scissor lift table mount**
- **VAS 6410 - Contact surface cleaning set**
- **VAS 6832 - Master Gear unit elevating platform**
- **VAS 6883A - Insulated tool set**
- **9890 - Socket wrench E12**
- **VAS 6890 - Spring band clamp pliers**
- **High-voltage testing module**
- **VAS 6558A/27 - Set of Kelvin clamps and test probes**
- **VAS 6931A - Transmission and engine jack**
- **VAS 6760A - Storage tray**
- **VAS 531 011 - Cooling system service equipment**
- **Torque wrench 40-200 Nm (30-248 ftlb.), e. g. V.A.G 1332A - Torque wrench, 40-200 Nm (30-248 ftlb.)**
- **Torque wrench, 2-10 Nm (2-8 ftlb.), e.g., V.A.G 1783 - Torque wrench, 2-10 Nm (2-8 ftlb.)**
- **Torque wrench, 0.4-2 Nm (0.3-1.5 ftlb.), e. g. VAS 6253A - Torque wrench, 0.4-2 Nm (0.3-1.5 ftlb.)**
- **Torque wrench, 6-50 Nm (4.5-37 ftlb.), e. g. V.A.G 1331A - Torque wrench, 6-50 Nm (4.5-37 ftlb.)**

Required parts and materials as needed



Information

No parts and materials are required for the initial test of the additional coolant pump for the low-temperature system (P2) with the Porsche Tester.

Parts
Information:

Part No.	Designation – Location of use	Quantity
----------	----------------------------------	----------

Required parts for checking the signal line for the additional coolant pump low-temperature system (P2):

976253725A	⇒ Clamp – Left exhaust system	1 piece(s)
976253725C	⇒ Clamp – Right front seat	1 piece(s)

N 90788402 ⇒ Fitting screw M 6 x 9 x 16 2 piece(s)
– Rear apron

Additional parts and materials required if the high-voltage battery must be replaced:

976915099 **XX*** ⇒ Hybrid battery 1 piece(s)
– Rear apron

PAG010006C **XXX*** ⇒ Information plate 1 piece(s)
– High-voltage battery

PAB010006B **XXX*** ⇒ Information plate 1 piece(s)
– High-voltage battery

PAB121809 ⇒ Seal 1 piece(s)
– Coolant reservoir for low-temperature system

V04015003P ⇒ Coolant additive 0.1 piece(s)
– Low-temperature system

*Determine the variant of the high-voltage battery and the warning stickers required for the respective vehicle using the vehicle identification number in the Porsche Spare Parts Catalogue (PET2).

Preparatory work

- Work Procedure: 1 Check function of additional coolant pump for low-temperature system (P2).
- 1.1 Connect and switch on the battery charger.
⇒ *Workshop Manual '270689A4 Charge battery and vehicle electrical system'*
 - 1.2 Place original remote control in emergency start tray.
 - 1.3 Connect **P90999 - Porsche Tester 4**, switch on the ignition and start the diagnostic application.
 - 1.4 Create vehicle analysis protocol and mark it with the attribute "**Pre-VAL**".
 - 1.5 Actuate additional coolant pump for low-temperature system (P2) via high-voltage battery control unit (BECM).

Assessment		Action
(✓)	Additional coolant pump for low-temperature system (P2) can be activated and is working.	Function OK. Continue troubleshooting otherwise. End of action.
(✗)	Additional coolant pump for low-temperature system (P2) cannot be activated.	Continue with Step ⇒ 2.

- 2 Check production date of the high-voltage battery.
To do this, read out the value "**Vehicle central information system (FAZIT) - identification**" from the Extended identifications menu for the high-voltage battery control unit.



Information

Example of measured value:

- MZS-MST**25.09.23**25560144

The first 6 digits are the production date. In this example 25.09.2023.

Assessment	Action
<ul style="list-style-type: none"> ▪ Production date of the high-voltage battery is 07/27/2025 or later 	Continue troubleshooting otherwise. End of action.
<ul style="list-style-type: none"> ▪ Production date of the high-voltage battery is 07/26/2025 or earlier 	Check signal line for additional coolant pump for low-temperature system (P2) Continue with. ⇒ <i>Technical Information '270689A4 Check signal line for additional coolant pump for low-temperature system (P2)'</i>

Check signal line for additional coolant pump for low-temperature system (P2)

- Work Procedure:
- 1 Observe general warning notes for working on the high-voltage vehicle electrical system.
⇒ *Workshop Manual '2X00INB2 General warning notes for working on the high-voltage vehicle electrical system'*
 - 2 Isolate HV system.
⇒ *Workshop Manual '277583A1 Deactivation/start of the high-voltage system'*
 - 3 Complete the documentation.
Procedure, see: ⇒ *Workshop Manual '2775INA4 Test log: Verifying isolation from the power supply'*
 - 4 Remove heat protection plate for **left** rear muffler.
Procedure see: ⇒ *Workshop Manual '261420A3 Removing and installing heat protection plates'*
 - 5 Expose additional coolant pump for low-temperature system (P2).
Procedure see: ⇒ *Workshop Manual '194519D7 Removing and installing additional coolant pump for low-temperature system (P2) - OK3'*

- 6 Release and disconnect electric plug connection for high-voltage battery ⇒ *Electric plug connection on high-voltage battery -1-*.

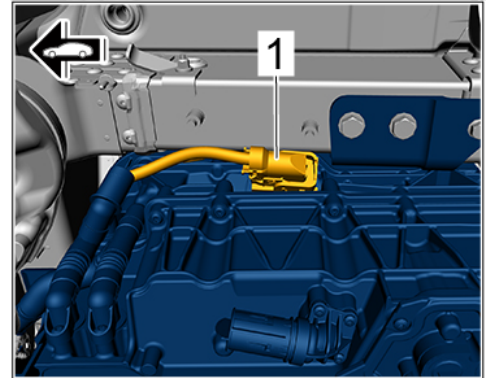

Electric plug connection on high-voltage battery

- 7 Release and disconnect electric plug connection of additional coolant pump P2 ⇒ *Additional coolant pump low-temperature system P2 -2-*.

- 8 Perform resistance test on signal line for additional coolant pump for low-temperature system (P2).

- 8.1 Set the multimeter to "resistance test".
- 8.2 Position measuring tip 1 of multimeter on electric plug connection for high-voltage battery **pin 6 (blue / grey)**.
- 8.3 Position measuring tip 2 of multimeter on electric plug connection for additional coolant pump for low-temperature system P2 **pin 2 (blue / grey)**.

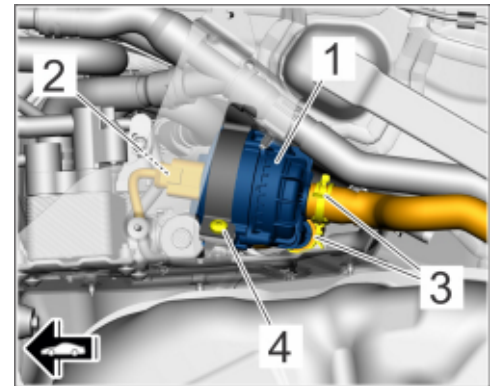

Additional coolant pump low-temperature system P2

- 9 Assess measured value.

Assessment		Action
(✓)	Resistance of the signal line is normal or unremarkable (< 0.5 Ω).	<p>Signal line OK.</p> <ul style="list-style-type: none"> Connect electric plug connection for additional coolant pump for low-temperature system P2, until it locks securely. Replace high-voltage battery. ⇒ <i>Workshop Manual '270855A3 Replace the high-voltage battery'</i>

		End of action.
(X)	Resistance of the signal line is too high or signal line is interrupted (> 0.5 Ω / O.L.).	Signal line damaged or interrupted. Locate damage, repair line and then complete the vehicle again. End of action.



Information

The fault pattern described here is caused by a pushed-back PIN ⇒ *Plug contact for high-voltage battery control unit -1-* in the high-voltage battery control unit (BMCE) ⇒ *Plug contact for high-voltage battery control unit -2-*. This control unit is integrated into the high-voltage battery.

There is currently no approval for a separate replacement of the high-voltage battery control unit (BMCE) for the Panamera (YAA/YAB).

If the PIN is damaged or pushed back, the entire high-voltage battery including the integrated control unit (BMCE) must therefore be replaced:

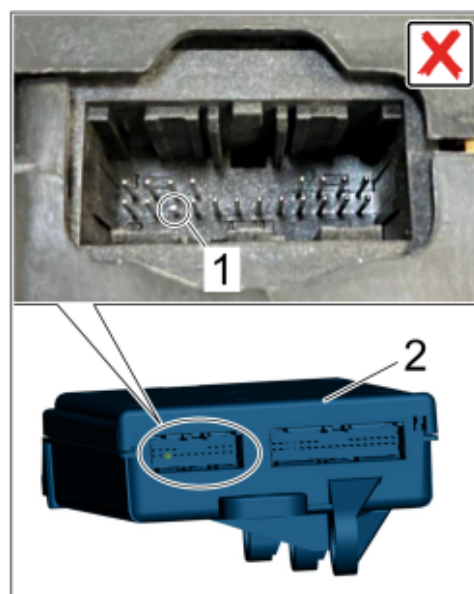

Plug contact for high-voltage battery control unit

Labor position and PCSS encryption

Labor position:

APOS	Labor operation	I No.
19450140	Check additional coolant pump low-temperature system, (activation)	
19450141	Check additional coolant pump low-temperature system (activation, read measured values)	
19450142	Check additional coolant pump low-temperature system (signal line)	
27085540	Replace the high-voltage battery	

PCSS encryption:

Location (FES5)	27080	High-voltage battery
Damage type (SA4)	4011	Loose contact, contact fault

Important Notice: Technical Bulletins issued by Porsche Cars North America, Inc. are intended only for use by professional automotive technicians who have attended Porsche service training courses. They are written to inform those technicians of conditions that may occur on some Porsche vehicles, or to provide information that could assist in the proper servicing of a vehicle. Porsche special tools may be necessary in order to perform certain operations identified in these bulletins. Use of tools and procedures other than those Porsche recommends in these bulletins may be detrimental to the safe operation of your vehicle, and may endanger the people working on it. Properly trained Porsche technicians have the equipment, tools, safety instructions, and know-how to do the job properly and safely. Part numbers listed in these bulletins are for reference only. The work procedures updated electronically in the Porsche PIWIS diagnostic and testing device take precedence and, in the event of a discrepancy, the work procedures in the PIWIS Tester are the ones that must be followed.

© 2026 Porsche Cars North America, Inc.