

Ventilation Does Not Function, Fault Memory Entry for Heating / Fresh-Air Blower "U125000" in the Main Control Unit for Body Electronics (HCP4) (SY 19/26)

Model Line: **Macan (XAB)**

Model Year: **As of 2024**

Concerns: **Front end fuse box**

Symptom: **The customer complains that the ventilation does not work perceptibly and automatically deactivates itself again after the desired setting.**

The following fault memory entry is stored in the main control unit for body electronics (HCP4):

- **U125000** - Heating / fresh air blower (J126), no communication (020202)

Cause: The stored fault code can indicate that the fuse for the heating / fresh-air blower (J126) may have improper contact. This can be caused by a damaged fuse carrier in the front end fuse box.

Remedial Action Check fuse for heating / fresh-air blower (J126) and replace front end fuse box if necessary.

Installation

Position:

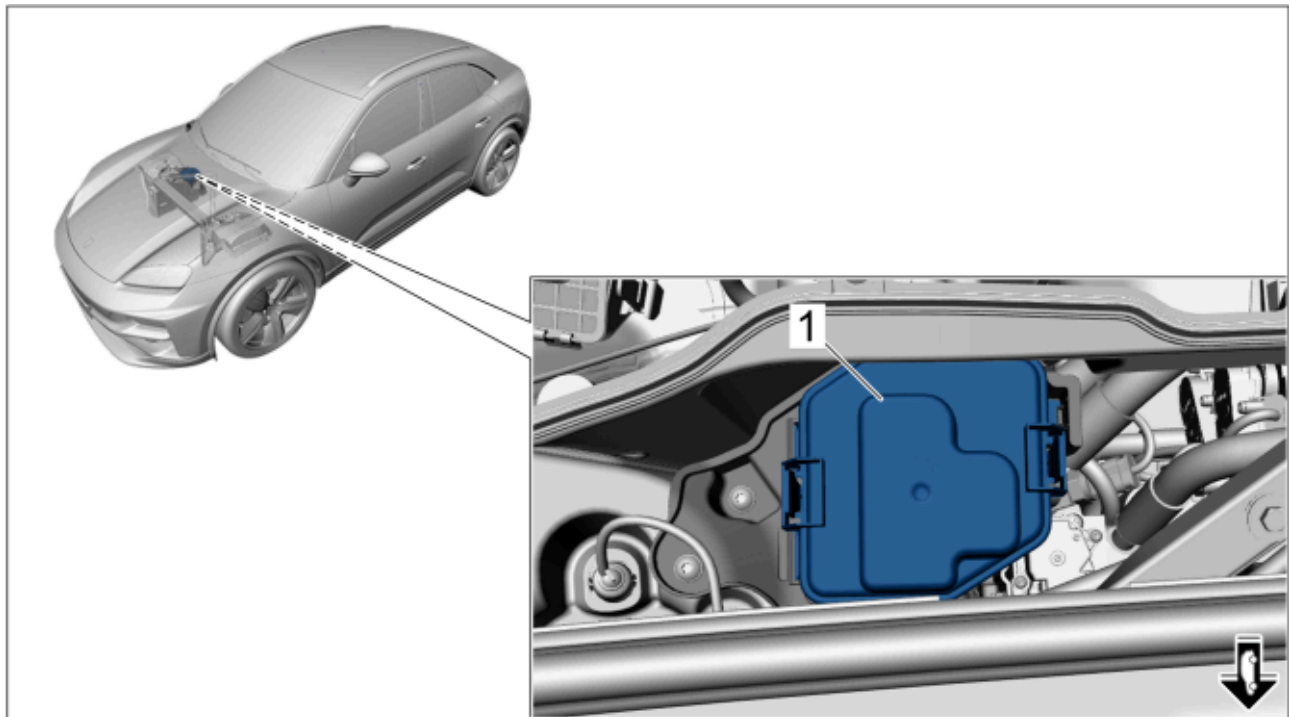

Installation position of front end fuse box (shown on left-hand drive vehicle)

1 – Front end fuse box

Required tools as needed**Information**

No tools are required for checking the front end fuse box.

Required tools for replacing the front end fuse box:

Tools:

- **P90999 - Porsche Tester 4**
- **VAS 6935 - Pole terminal puller**
- Torque wrench, 2-10 Nm (2-8 ftlb.), e.g., **V.A.G 1783 - Torque wrench, 2-10 Nm (2-8 ftlb.)**
- Torque wrench, 6-50 Nm (4.5-37 ftlb.), e. g. **V.A.G 1331A - Torque wrench, 6-50 Nm (4.5-37 ftlb.)**

Parts required as needed**Information**

No parts are required for checking the front end fuse box.

Required parts for replacing the front end fuse box:

Part No.	Designation	Number
Only for left-hand drive vehicles (M-no.LOL):		
PAD937124	⇒ Front end fuse box	1 piece(s)

Check fuse for heating / fresh-air blower (J126)**Information**

The test is shown on a left-hand drive vehicle as an example. The procedure on a right-hand drive vehicle is almost identical.

Work Procedure: 1 Unclip cover ⇒ *Unclipping cover -1-*.

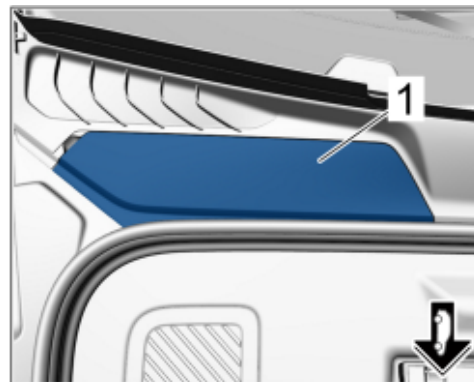

Unclipping cover

- 2 Unclip and remove cover ⇒ *Remove cover for front end fuse box -1-* of front end fuse box at retaining clips ⇒ *Remove cover for front end fuse box -2-*.
- 3 Remove fuse for heating / fresh-air blower (J126) and check contact marks on the plug contacts.

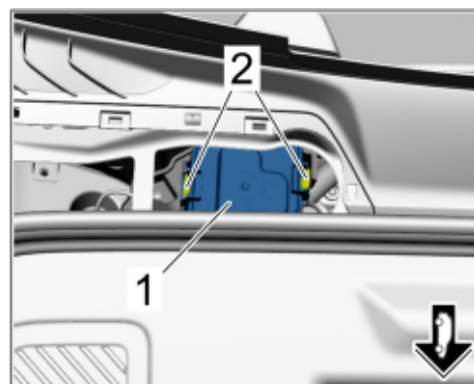

Remove cover for front end fuse box

**Information**

The fuse (40A) for the heating / fresh-air blower (J126) is located on the **front end fuse carrier (fuse holder A)**, slot F28.

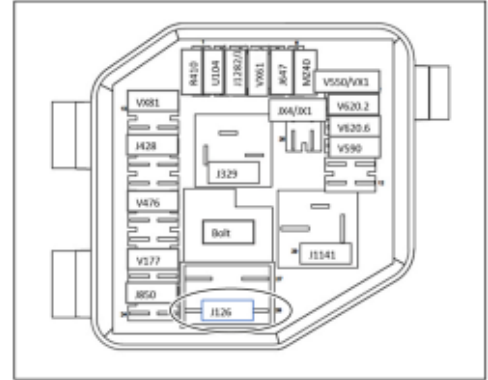

Overview of front end fuse carrier (fuse holder A) (shown on left-hand drive vehicle)

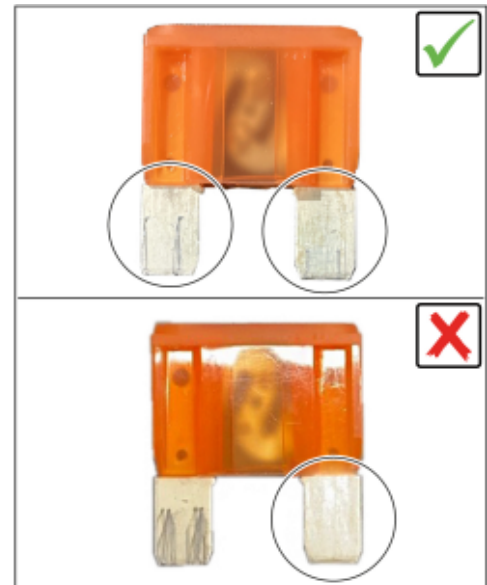

Check fuse for contact marks on plug contacts

Assessment		Action
(✓)	Contact marks can be seen on both plug contacts of the fuse.	Front end fuse box OK <ul style="list-style-type: none"> ▪ Re-insert the fuse ▪ Continue troubleshooting elsewhere ▪ Reassemble the vehicle again after repairs End of action.
(✗)	Contact marks cannot be recognized on both plug contacts of the fuse.	Front end fuse box not OK. Replace front end fuse box For work procedure, see: ⇒ <i>Technical Information '97841901 Removing and installing front end fuse box fuse carrier'</i> End of action.

Labor operation and PCSS encryption

Labor operation:

APOS	Labor operation	I No.
85300140	Check fuse for heating / fresh-air blower (J126)	
97845549	Checking fuse for heating / fresh-air blower (J126) and replacing front end fuse box	

PCSS encryption:

Location (FES5)	85300	Heating / fresh-air blower
Damage type (SA4)	1611	does not function

Important Notice: Technical Bulletins issued by Porsche Cars North America, Inc. are intended only for use by professional automotive technicians who have attended Porsche service training courses. They are written to inform those technicians of conditions that may occur on some Porsche vehicles, or to provide information that could assist in the proper servicing of a vehicle. Porsche special tools may be necessary in order to perform certain operations identified in these bulletins. Use of tools and procedures other than those Porsche recommends in these bulletins may be detrimental to the safe operation of your vehicle, and may endanger the people working on it. Properly trained Porsche technicians have the equipment, tools, safety instructions, and know-how to do the job properly and safely. Part numbers listed in these bulletins are for reference only. The work procedures updated electronically in the Porsche PIWIS diagnostic and testing device take precedence and, in the event of a discrepancy, the work procedures in the PIWIS Tester are the ones that must be followed.

© 2026 Porsche Cars North America, Inc.