

**WPL8 - Replacing Electric Passenger Compartment Heater (Workshop Campaign)**

Change  
Overview:

Release	Date	Change
0	10/05/2023	<ul style="list-style-type: none"> <li>▪ First publication</li> </ul>
1	11/08/2023	<ul style="list-style-type: none"> <li>▪ Update to Part Information</li> </ul>
2	11/29/2023	<ul style="list-style-type: none"> <li>▪ Update to Information note &amp; TU</li> </ul>
3	04/10/2024	<ul style="list-style-type: none"> <li>▪ Deletion of Information note &amp; Update of TU</li> </ul>
4	11/25/2025	<ul style="list-style-type: none"> <li>▪ Update to include Scope 4 along with corresponding information throughout TI</li> <li>▪ Update to Scope 1 'Work Procedure' section</li> </ul>
5	03/03/2026	<ul style="list-style-type: none"> <li>▪ Update to Warranty Processing, Scope 1 removed</li> <li>▪ Deletion of Information note</li> <li>▪ Update to materials</li> </ul>

Model Year: **As of 2020 up to 2023**

Model Line: **Taycan (Y1A/Y1B/Y1C)**

Concerns: **Electric passenger compartment heater**

Cause: **Due to a potential material error, the heater coating in the electric passenger compartment heater can become detached on the affected vehicles during prolonged utilization of the heating and with high heating output, especially in countries with frequently cold environmental conditions.**  
This may result in the heating function being impaired and the vehicle not defrosting properly when driving.

Action: Replace electric passenger compartment heater.

Affected  
Vehicles:

Only vehicles assigned to the Campaign (see also PCSS Vehicle Information).



#### Information

Please note that even on vehicles not assigned to this campaign, the high-voltage heater may fail for various reasons. These vehicles must be processed via the standard repair process (car down case) and will not be reactively assigned to this campaign.

Installation  
Position:

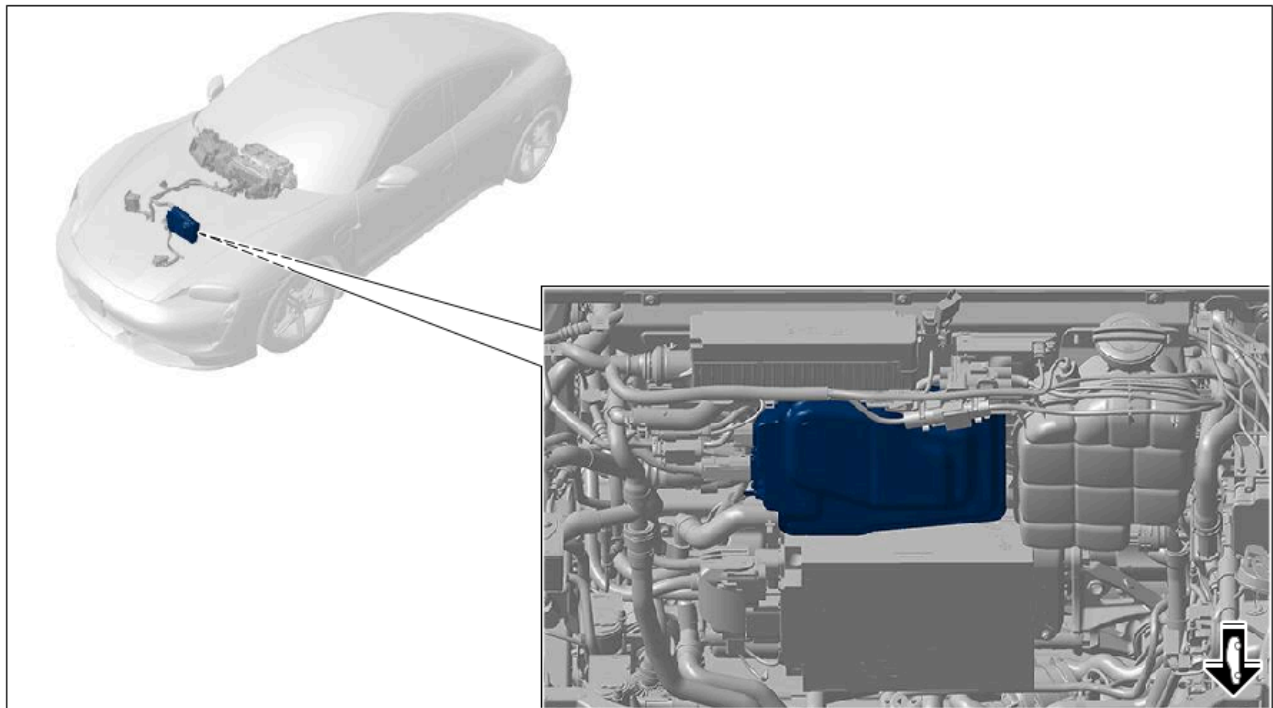

*Installation position*

– (Replacing) **Electric passenger compartment heater**

### Required parts and materials



#### Information

According to the latest knowledge, it is **no longer necessary** to replace the hexagon nut (N 10737001) and the hexagon socket screw (N 91096801) when replacing the electric passenger compartment heater. **These can therefore be reused.** For this reason, the two part numbers mentioned are removed from this campaign. For the transitional period, it will continue to be possible to invoice these after installation. The remaining stocks of the internal hexagon round-head bolt (N 91096801) and the hexagon nut (N 10737001) on the market can be used up if necessary. It is not necessary to return the parts.

Parts Info:	<b>Part No.</b>	<b>Designation</b>	<b>Number</b>
	V04015007AK	⇒ Electric passenger compartment heater	1 piece



#### Information

From 11/1/23 forward, the campaign part # will not be available to order. As communicated via PPN, the spare part # for the HV Heater will be used for both WPL8 and Car Down (non-campaign) repairs. Either part can be invoiced in WWS for the campaign.

The spare part is:

Parts Info:	<b>Part No.</b>	<b>Designation</b>	<b>Number</b>
	PAD963507A	⇒ Electric passenger compartment heater	1 piece

Materials: **Only if required** (usually already available in the Porsche Center):

<b>Part No.</b>	<b>Designation</b>	<b>Quantity</b>
N 10737001	⇒ Hexagon nut, self-locking	4 pieces
00004330516	⇒ Coolant additive, 20-liter (5.28 gal) container – Cooling system	Quantity as required*

\* For complete emptying, a maximum of 0.5 liters (16.9 fl-oz) is required for each vehicle and approx. 0.15 liters (5.0 fl-oz) for partial emptying

#### Required tools

- **VAS 6883A - Insulated tool set**
- **VAS 6890 - Spring band clamp pliers**
- Torque wrench, 2-10 Nm (1.5-7.5 ftlb.), e.g. **V.A.G 1783 - Torque wrench, 2-10 Nm (1.5-7.5 ftlb.)**
- **VAS 531 011 - Cooling system service equipment**
- **3093 - Hose clamp**
- **VAS 6675A - Funnel**
- Battery charger with a current rating of **at least 90 A** and - if required - **also** with a **current and voltage controlled charge map** for lithium starter batteries, e.g. **VAS 5908 – 90 A battery charger**
- **P90999 - Porsche Tester 4**

Replace electric heater for passenger compartment (scope 4 - replacement with partial emptying of the cooling system)

 **WARNING**

**Incorrect handling of high-voltage components**

- Electric shock
  - Short circuit
  - Fire
  - Explosion
- ⇒ Only appropriately trained and authorized persons are permitted to work on high-voltage vehicles and components.
- ⇒ Required qualification: High voltage technician or high voltage expert.
- ⇒ Observe national requirements and legislation for this work.
- ⇒ Always use insulated tools such as the insulated tool set when working on these parts.
- ⇒ Observe general warning notices for working on the high-voltage system. ⇒ *Workshop Manual '2X00INB5 General warning notices for working on the high-voltage system'*

 **WARNING**

**Hot fluid**

- Danger of scalding
- ⇒ Avoid contact with hot fluid.
- ⇒ Wear personal protective gear.

 **CAUTION**

**Hot components**

- Risk of burns
- ⇒ Let hot components cool down.
- ⇒ Wear personal protective gear.



**Information**

- Protect high-voltage plug connections from dampness.
- Do not release high-voltage plug connections until you have opened the cooling system.



## Information

### Handling high-voltage lines:

- Do not support yourself or your tools on high-voltage lines and their components.
- Work involving metal-cutting, deforming and sharp-edged tools close to high-voltage components and lines is prohibited.
- Work involving heat sources such as welding, soldering, hot air and thermal bonding close to high-voltage components and lines is prohibited.
- High-voltage lines must not be extensively bent or kinked.
- A visual inspection of the high-voltage connectors must be performed before installing the high-voltage lines. If there are signs of damage to the connectors, contacts and gaskets, the high-voltage line must be replaced.
- If you have questions or if you are unclear about anything, consult the relevant high-voltage technician.

- Work Procedure:
- 1 Deactivate the high-voltage system.  
⇒ *Workshop Manual '277583A2 Deactivating and activating the high-voltage system'*
  - 2 Remove the luggage compartment tray.  
⇒ *Workshop Manual '501919A1 Removing and installing the luggage compartment tray'*
  - 3 Loosen the front end fuse box.  
⇒ *Workshop Manual '978409A1 Loosening and fastening the front end fuse box'*
  - 4 Read the warning notices.  
⇒ *Workshop Manual '2X00INB4 General warning notices for working on the high-voltage vehicle electrical system'*
  - 5 Mark the current coolant level on the reservoir.



Reservoir

**Information**

Please note that only vehicles with equipment add-on **auxiliary heater (M No. 9M3)** is a thermal insulation (case) **additionally** ⇒ *Thermal insulation (case) -1-* installed on the electric passenger compartment heater. This must be converted from the old to the new electric passenger compartment heater.

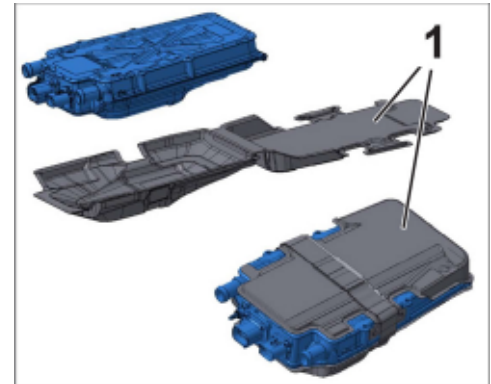
*Thermal insulation (case)*

- 6 Remove the protective cover ⇒ *Protective cover -1-*.
  - 6.1 Unscrew nuts ⇒ *Protective cover -2-*.
  - 6.2 Unscrew screw ⇒ *Protective cover -3-*.
  - 6.3 Remove the protective cover ⇒ *Protective cover -1-*.

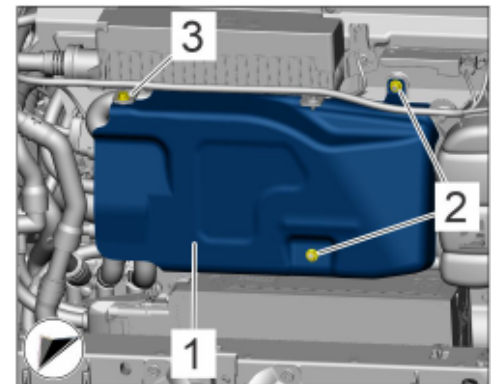
*Protective cover*

- 7 Disconnect the coolant hoses **as close as possible** to the coolant connection piece for the electric passenger compartment heater using commercially available hose clamps ⇒ *Coolant hoses*.

*Coolant hoses*

8 Disconnect the coolant hoses ⇒ *Coolant hoses on the electric passenger compartment heater -2-* from the electric passenger compartment heater ⇒ *Coolant hoses on the electric passenger compartment heater -1-*.

8.1 Position suitable collection tank and cloths for leaking coolant and ensure that no coolant can reach the electrical contacts.

8.2 Loosen spring band clamps ⇒ *Coolant hoses on the electric passenger compartment heater -3-*.

8.3 Disconnect the coolant hoses ⇒ *Coolant hoses on the electric passenger compartment heater -2-* and close them off immediately using suitable stoppers.

8.4 Close off the connection openings on the electric passenger compartment heater ⇒ *Coolant hoses on the electric passenger compartment heater -1-* using suitable stoppers.

9 Release and disconnect the electric plug connections and pull the bracket ⇒ *Connector bracket on body -1-* off the body ⇒ *Connector bracket on body -Arrow-*.

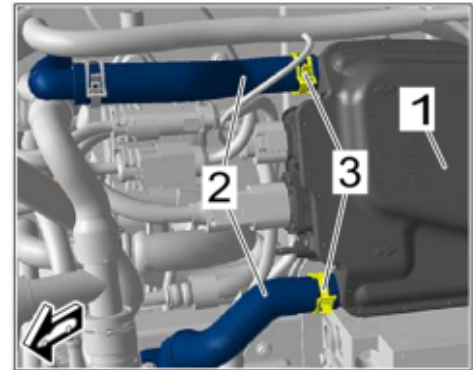

*Coolant hoses on the electric passenger compartment heater*

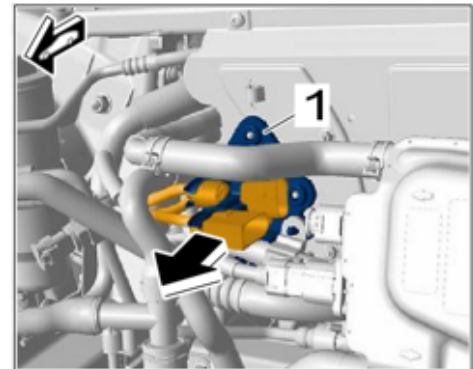

*Connector bracket on body*

- 10 Unscrew the nut ⇒ *Potential equalization line on electric passenger compartment heater -3-* from the potential equalization line ⇒ *Potential equalization line on electric passenger compartment heater -2-* on the electric passenger compartment heater ⇒ *Potential equalization line on electric passenger compartment heater -1-* and remove the potential equalization line ⇒ *Potential equalization line on electric passenger compartment heater -2-*.

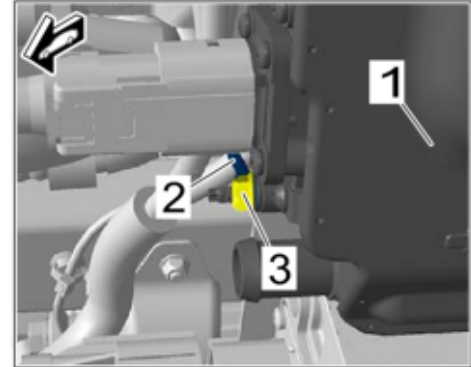

*Potential equalization line on electric passenger compartment heater*

- 11 Unlock and pull off electric plug connection ⇒ *Electric plug connection for electric passenger compartment heater -2-*.

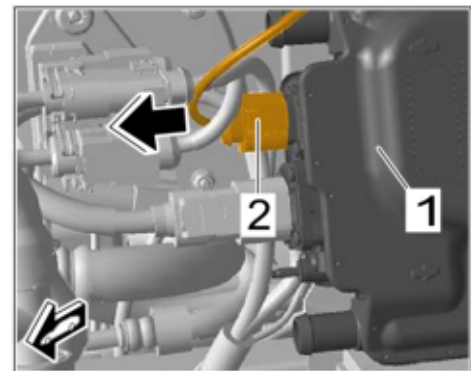

*Electric plug connection for electric passenger compartment heater*

- 12 Release and disconnect high-voltage plug connection ⇒ *High-voltage connection for electric passenger compartment heater -2-*.

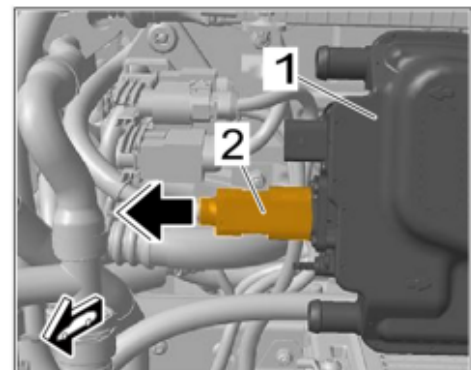

*High-voltage connection for electric passenger compartment heater*

- 13 Loosen the reservoir ⇒ *Reservoir on body -1-*.
  - 13.1 Unscrew nuts ⇒ *Reservoir on body -3-*.
  - 13.2 Turn reservoir ⇒ *Reservoir on body -1-* to the side ⇒ *Reservoir on body -Arrow-* until nut becomes ⇒ *Reservoir on body -4-* accessible.

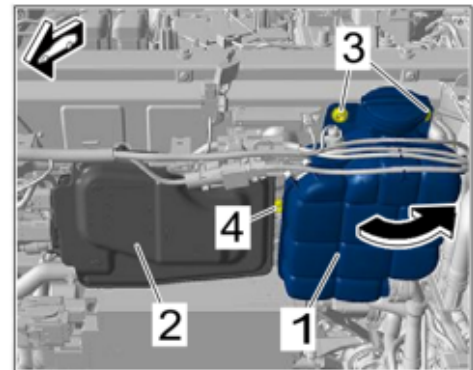

*Reservoir on body*

- 14 Remove the electric passenger compartment heater ⇒ *Electric passenger compartment heater on body -1-*.
  - 14.1 Remove nuts and one screw (center left) ⇒ *Electric passenger compartment heater on body -3-* from the bracket.
 

The nuts ⇒ *Electric passenger compartment heater on body -3-* must be replaced.
  - 14.2 Remove the electric passenger compartment heater ⇒ *Electric passenger compartment heater on body -1-*.

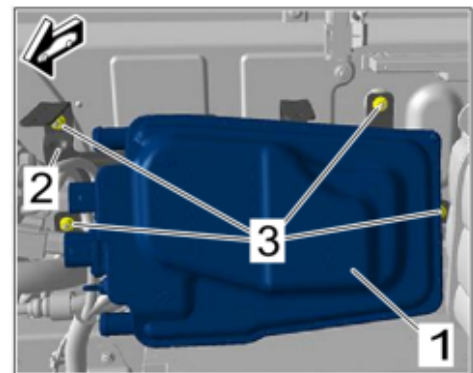



*Electric passenger compartment heater on body*

- 15 Pre-fill the **new** electric passenger compartment heater with **new** coolant.
  - 15.1 Fill 250 ml of coolant (filling volume of electric passenger compartment heater) into a measuring cup.
  - 15.2 Use a funnel to fill coolant into the vertical electric passenger compartment heater. Fill coolant in both connection pieces. ⇒ *Electric passenger compartment heater*
  - 15.3 Close off the connection pieces using stoppers.
  - 15.4 Slowly tilt the electric passenger compartment heater in all directions one after the other to remove any remaining air bubbles from the electric passenger compartment heater.
  - 15.5 Remove the stoppers and check the coolant level in the electric passenger compartment heater.



*Electric passenger compartment heater*

- 15.6 Repeat work steps 15.2 to 15.5 until the electric passenger compartment heater is completely filled with coolant.
- 15.7 Close off the connection pieces using stoppers.
- 16 Install in reverse order, paying particular attention to the following:
-  **Information**  
During assembly of the pre-filled electric passenger compartment heater, make sure that as little coolant as possible leaks.  
High loss of coolant has a negative effect on the subsequent activities.
-  **Information**  
If the bulkhead has been replaced, the studs fastening the electric passenger compartment heater holder are replaced by welded nuts.  
In this case, tighten screws (see PET) to the same tightening torque (as for nuts used previously).
- 16.1 Tighten nut for equipotential bonding line with **Tightening torque 8 Nm (5.9 ftlb.)**.
- 16.2 Tighten **new** nuts in electric passenger compartment heater with **Tightening torque 8 Nm (5.9 ftlb.)**.
- 16.3 Tighten screw on electric passenger compartment heater with **Tightening torque 8 Nm (5.9 ftlb.)**.
- 16.4 Tighten screw and nuts on protective cover with **Tightening torque 8 Nm (5.9 ftlb.)** .
- 16.5 Tighten nut for reservoir with **Tightening torque 8 Nm (5.9 ftlb.)**.
- 17 Secure the front end fuse box.  
⇒ *Workshop Manual '978409A1 Loosening and fastening the front end fuse box'*
- 18 Perform the "Bleeding the cooling system" tester routine **twice** in succession (**without** draining and filling coolant beforehand).  
⇒ *Workshop Manual '190107A5 Bleeding the cooling system'*
- 19 Add coolant to the reservoir up to the marking (see removal, action step ⇒ 5).  
If **more** than 150 ml of coolant must be refilled, further activities are required.  
For this purpose, log in with a PRMS ticket to the PAG\_Campaign\_TI\_SY\_Support group for further instructions.
- 20 Activate high-voltage system.  
⇒ *Workshop Manual '277583A2 Deactivating and activating the high-voltage system'*



**Information**

For the technical information for the new electric passenger compartment heater to be **back-documented correctly, the Porsche Tester must be logged in online** and in the Porsche Partner Network (PPN).

- 21 Teach the electric passenger compartment heater.  
⇒ *Workshop Manual '828055 Replacing electric passenger compartment heater'*
- 22 Install the luggage compartment tray.  
⇒ *Workshop Manual '501919A1 Removing and installing the luggage compartment tray'*
- 23 Enter the campaign in the warranty and maintenance logbook.  
Continue with warranty processing, Scope 4 ⇒ *Technical Information '501919A1 Warranty processing'*

**Warranty processing**



**Information**

The specified labor times were determined specifically for carrying out this campaign and include all of the necessary preliminary and subsequent rework. The labor times can differ from the labor time published in the Labor Operation List in the PCSS.

Scope 1 to 3: **Not valid**

Scope 4: Replacing electric passenger compartment heater

- Partial emptying of the cooling system

<b>Labor time:</b>		
Replacing electric passenger compartment heater		Labor time: <b>448 TU</b>
Includes:	Deactivating and activating high-voltage system Bleeding the cooling system Removing and installing the luggage compartment tray Removing and installing front cover Loosening and fastening the front end fuse box Loosening and fastening ground strap for battery	
<b>Required parts:</b>		
PAD963507A	Electric passenger compartment heater	1 piece
<b>Required materials (only if needed):</b>		
00004330516	Coolant additive (20-liter (5.28 gal) container)	0.01 piece

N10737001

Hexagon nut, self-locking

4 pieces

⇒ **Damage number WPL8 066 000 2**

## Customer mobility/Vehicle transport

### Customer mobility for the duration of the carrying out the action

If necessary, customer mobility can be granted and invoiced. As a rule, the current rules governing the Customer Mobility Program apply here.

#### – Utilization of Porsche and Audi vehicles via Mobility Account (standard process):

Costs are processed using the standard process in accordance with the currently applicable rules governing the Customer Mobility Program.

#### – Utilization of vehicles from other group brands (VW, Seat, Skoda):

If necessary, vehicles from other group brands can be used as an alternative.

The costs incurred in the campaign claim can be invoiced as external services (sublets) in the campaign application for WPL8 workshop campaign.

Please attach a copy of the invoice to the campaign claim in "External services".

In particular in cold weather conditions, if there are time delays between possible vehicle handover by the customer and implementation of the action due to finding an appointment with the customer and replacement transport is granted over a longer period of time, the remaining costs can be borne from the local customer goodwill budget.

### Vehicle collection from customer (collection and delivery service)

If the customer cannot keep a workshop appointment at short notice to carry out the action, offer to collect the vehicle from the customer and return it after the repair has been completed (collection and delivery service). This service can be invoiced via the mobility voucher in accordance with the applicable preconditions.

If the costs actually incurred exceed the value of the mobility voucher, the remaining amount can be borne from the local customer goodwill budget.

### Vehicle collection from customer (vehicle transport)

If necessary, the customer can also arrange for the vehicle to be collected and transported to the workshop via the respective Porsche Center. Vehicle transport must be commissioned and invoiced by the Porsche Center responsible.

The costs incurred in the campaign claim can be invoiced as external services (sublets) in the campaign application for WPL8 workshop campaign. Please attach a copy of the invoice to the campaign claim in "External services".

**Important Notice:** Technical Bulletins issued by Porsche Cars North America, Inc. are intended only for use by professional automotive technicians who have attended Porsche service training courses. They are written to inform those technicians of conditions that may occur on some Porsche vehicles, or to provide information that could assist in the proper servicing of a vehicle. Porsche special tools may be necessary in order to perform certain operations identified in these bulletins. Use of tools and procedures other than those Porsche recommends in these bulletins may be detrimental to the safe operation of your vehicle, and may endanger the people working on it. Properly trained Porsche technicians have the equipment, tools, safety instructions, and know-how to do the job properly and safely. Part numbers listed in these bulletins are for reference only. The work procedures updated electronically in the Porsche PIWIS diagnostic and testing device take precedence and, in the event of a discrepancy, the work procedures in the PIWIS Tester are the ones that must be followed.

© 2026 Porsche Cars North America, Inc.