

WSSO - Checking the Return Line (PDCC) and Replacing if Necessary (Workshop Campaign)

Change
Overview:

Revision	Date	Change
0	02/04/2026	▪ First publication
1	03/02/2026	▪ Change to date in assessment/action table in work procedure

Model Year: **As of 2025 up to 2026**

Vehicle Type: **911 Carrera GTS (992)
911 Carrera 4 GTS (992)
911 Turbo S (992)**

Equipment: Porsche Dynamic Chassis Control (PDCC) (M-No. 1P7)

Concerns: **Return line (PDCC)**

Cause: **Due to a manufacturing error, there is a possibility that the return line of the PDCC system is leaking in the area where it adjoins the PDCC pump on the affected vehicles.**
This may lead to oil loss and consequently to the deactivation of the PDCC system. Deactivation is warned in yellow on the instrument cluster; the vehicle remains ready to drive.



Information

The vehicle is still ready to drive with the yellow warning message and deactivated anti-roll stabilisation.

Action: Check the return line (PDCC) and replace it if necessary.

Affected Vehicles: Only vehicles assigned to the Campaign (see also PCSS Vehicle Information).

Installation

Position:

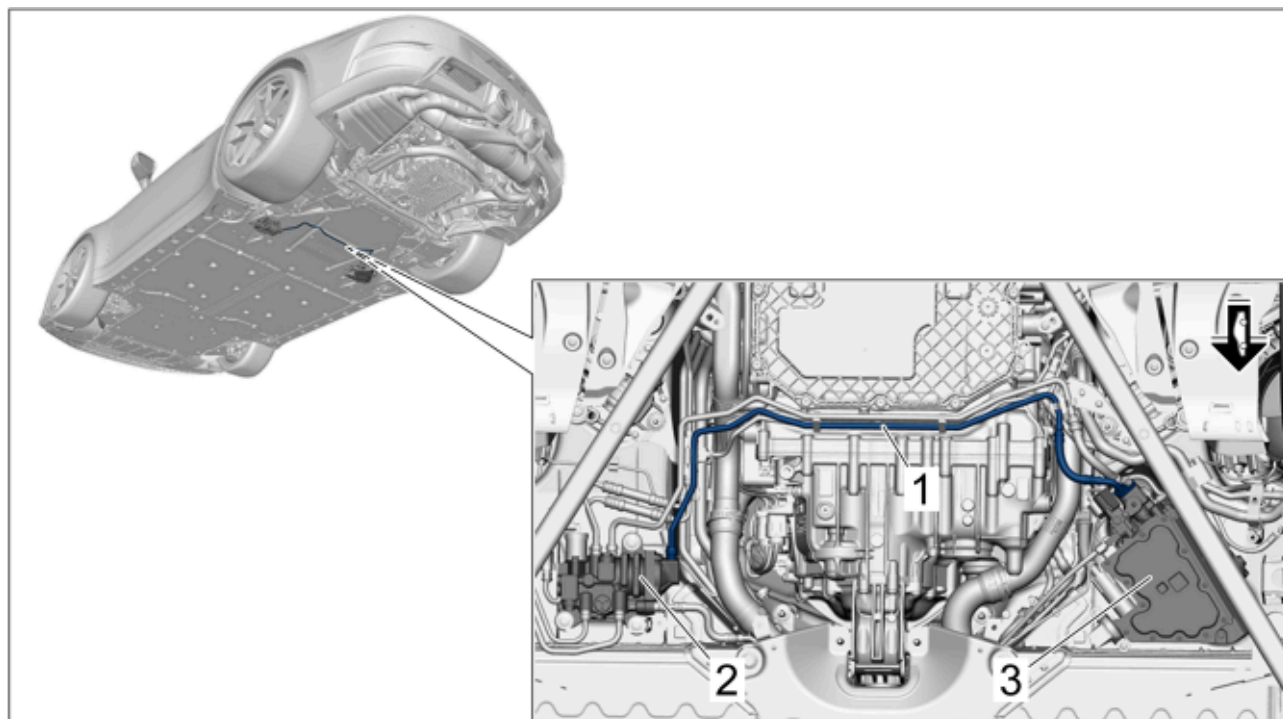

Installation position of return line (PDCC)

- 1 – Return line (PDCC) **(check and replace if necessary)**
- 2 – (Rear) valve block
- 3 – Pump (PDCC)

Required parts as needed



Information

No parts are required for checking the return line (PDCC).

Parts Info:

Part No.	Designation – Location of use	Quantity
V04015010S	⇒ Return line – PDCC system	1 piece
N 10517304	⇒ Cheese head bolt with multiple-tooth head, self-locking M8 x 22 – Return line on pump (PDCC)	1 piece

Material: **Required material** (usually already available at the Porsche Centre)

Part No.	Designation – Location of use	Quantity
00004330574	⇒ Hydraulic oil 1 liter/ 33.8 fl oz container – PDCC system	2 pieces

Required tools as needed

- Tools:
- **P90999 - Porsche Tester 4**
 - Battery charger with a current rating of **at least 90 A** and a **current and voltage-controlled charge map** for lithium starter batteries, e.g. **VAS 5908 - battery charger 90 A**. For further information about the battery chargers to be used, see the corresponding Workshop Manual. ⇒ *Workshop Manual '270689 Charge battery and vehicle electrical system'*
 - Torque wrench, 2-10 Nm (1.5-7.5 ftlb.), e.g. **V.A.G 1783 - torque wrench, 2-10 Nm (1.5-7.5 ftlb.)**
 - Torque wrench, 6-50 Nm (4.5-37 ftlb.), e.g. **V.A.G 1331A - torque wrench, 6-50 Nm (4.5-37 ftlb.)**
 - **VAS 6883A - Insulated tool set**
 - **VAS 6558B - High-voltage measuring module**
 - **VAS 6558A/50 - High-voltage measuring adapter set**
 - **VAS 6558A/27 - Set of Kelvin clamps and test probes**
 - **VAS 6410 - Contact surface cleaning set**
 - **T40262 - Locking cap**
 - **VAS 6544A - Filling equipment**
 - **VAS 6096/2 - Vacuum pump**
 - **P90101 - Loosening tool**
- or
- **VAS 6933 - Disassembly tool**

Checking the return line (PDCC)

- Work Procedure:
- 1 Remove rear cover.
⇒ *Workshop Manual '519419A4 Removing and installing rear cover'*
 - 2 Check the production date ⇒ *Example illustration with production date 19.09.2025 -1-* of the return line (PDCC).

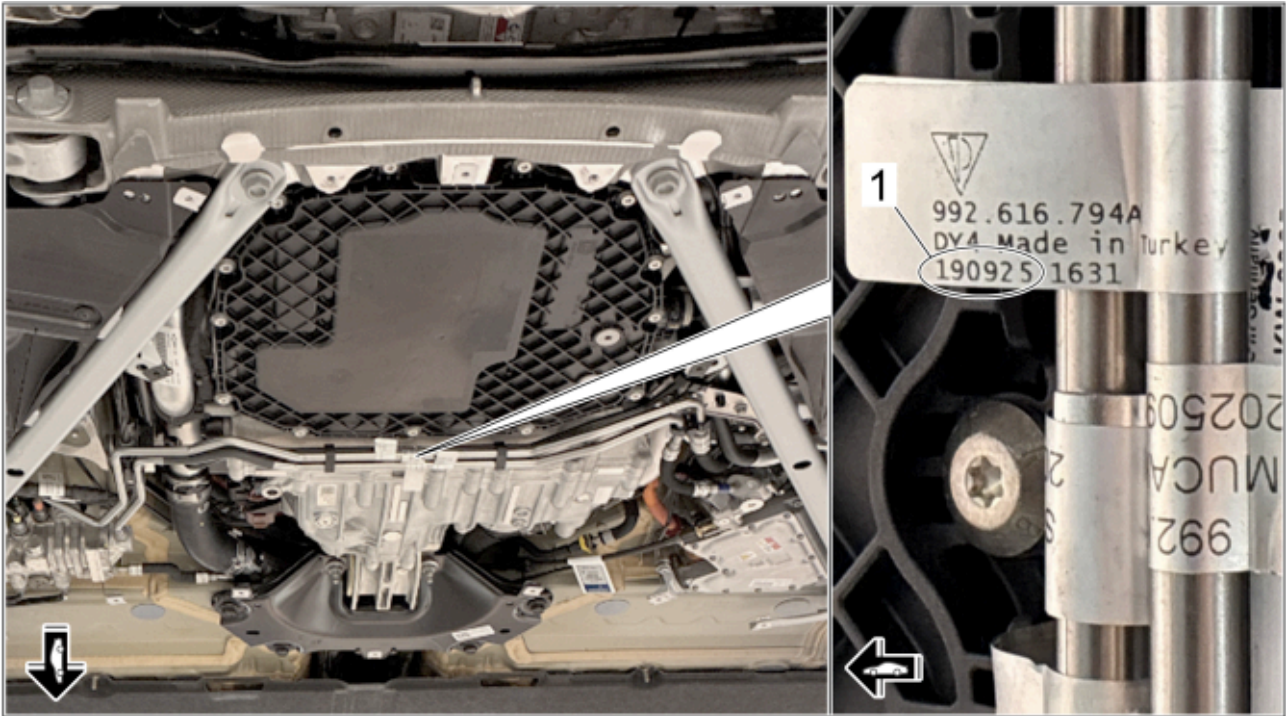

Example illustration with production date 19.09.2025

Assessment		Action
(✓)	The production date of the return line (PDCC) is not 16/03/2025.	<p>The return line (PDCC) is OK.</p> <p>Install the rear cover. ⇒ <i>Workshop Manual '519419A4 Removing and installing the rear cover'</i></p> <p>Enter the campaign in the warranty and maintenance logbook.</p> <p>End of action.</p> <p>Invoicing for Scope 1.</p>
(x)	The production date of the return line (PDCC) is 16/03/2025 .	<p>The return line (PDCC) is not OK.</p> <p>Continue with ⇒ <i>Technical Information '519419A4 Replacing the return line (PDCC)'</i>.</p> <p>Invoicing for Scope 2.</p>

Replacing return line (PDCC)



Corrosive fluids

- **Chemical burns**
- ⇒ **Wear personal protective equipment.**
- ⇒ **Ensure that there is good ventilation.**
- ⇒ **Avoid contact with corrosive fluid.**
- ⇒ **If you come into contact with it, wash off immediately with plenty of warm water and contact a doctor if necessary.**

NOTICE**Aggressive fluids**

- **Damage to components and surfaces**
- ⇒ **Do not spill fluids.**
- ⇒ **In case you touch it, wash the component or surface with water.**
- ⇒ **Replace components that are already damaged.**

**Information**

- Open connections and lines must be closed off using suitable stoppers or caps.

**Information**

Collect any fluid that leaks out in a suitable container.

- Work Procedure:
- 1 Deactivate the high-voltage system.
⇒ *Workshop Manual '277583A3 Deactivating and activating high-voltage system'*
 - 2 Bleed PDCC (system).
⇒ *Workshop Manual '430317A3 Bleeding and filling PDCC (system)'*
 - 3 Remove the support plate.
⇒ *Workshop Manual '421419A1 Removing and installing support plate'*

**Information**

- When cleaning the PDCC system components using a high-pressure cleaner, make sure that the high-pressure spray is at least 50 cm/ 19.68 in away from the component to prevent damage to electric lines, connectors and contacts.
- Carefully clean the hydraulic connections in the area around the connection points (using a paintbrush and/or a lint-free cloth, for example).

- 4 Thoroughly clean connection areas ⇒ *Connection areas, return line (PDCC) -4-* of the return line (PDCC) ⇒ *Connection areas, return line (PDCC) -1-* on the pump (PDCC) ⇒ *Connection areas, return line (PDCC) -2-* and valve block (rear) ⇒ *Connection areas, return line (PDCC) -3-* to prevent contamination of the hydraulic system.

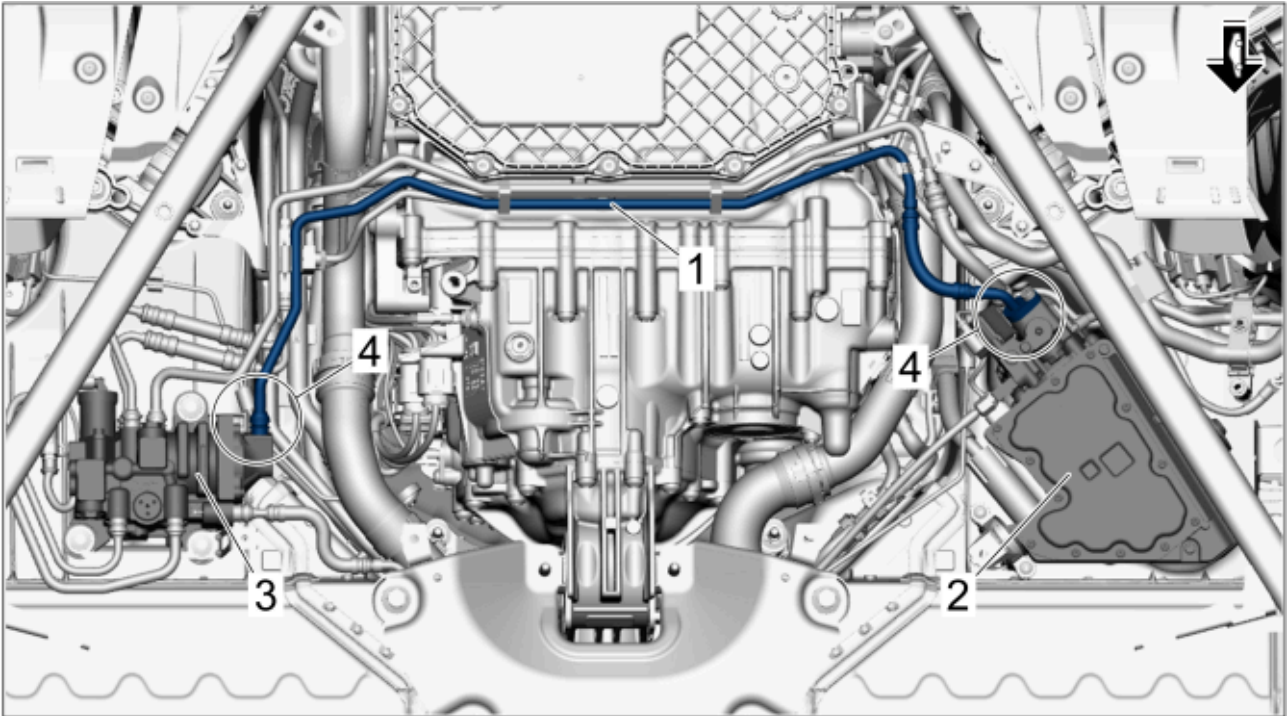

Connection areas, return line (PDCC)

- 5 Unscrew screw ⇒ *Return line (PDCC) to pump (PDCC) -2-* and ⇒ *Return line (PDCC) to pump (PDCC) -1-* remove return line (PDCC) ⇒ *Return line (PDCC) to pump (PDCC) -3-* from pump (PDCC).

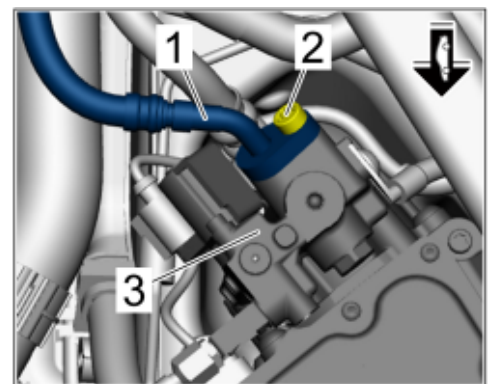

Return line (PDCC) to pump (PDCC)



Information

The 992 II is equipped with the **P90101 - loosening tool** for loosening hydraulic lines (PDCC). The **VAS 6933 - disassembly tool** can be used as an alternative until the market launch (expected in calendar week 49/2025). In hard-to-reach places, an open-ended spanner can be used for unlocking.

To loosen the hydraulic line (PDCC), push the **P90101 - loosening tool** ⇒ *Example illustration of hydraulic line with the loosening tool P90101 -1-* as far as it will go, actuate lock ⇒ *Example illustration of hydraulic line with the loosening tool P90101 -Arrow A-* and pull off hydraulic line (PDCC) ⇒ *Example illustration of hydraulic line with the loosening tool P90101 -Arrow B-*.

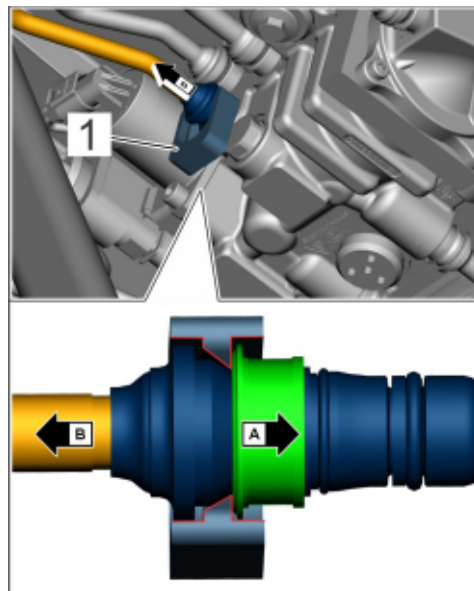

Example illustration of hydraulic line with the loosening tool P90101

- 6 Loosen and remove the return line (PDCC) ⇒ *Return line (PDCC) to valve block (rear) -1-* with the **P90101 - loosening tool** or alternatively with the **VAS 6933 - disassembly tool** from the valve block (rear) ⇒ *Return line (PDCC) to valve block (rear) -2-*.

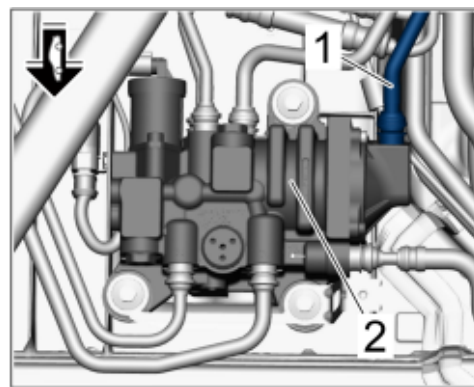

Return line (PDCC) to valve block (rear)

NOTICE

Incorrect line routing

- **Damage to lines and hoses**
- **Malfunction and fault memory entry on control units**

- ⇒ Prevent small bending radii in the lines.
- ⇒ File down edges and burrs in the routing area or mask them with adhesive tape.
- ⇒ Maintain a sufficient distance from components subjected to high temperatures during driving.

- 7 Unclip and remove previous return line (PDCC) ⇒ Return line brackets (PDCC) -1- from brackets, ⇒ Return line brackets (PDCC) -2- clip **new** return line (PDCC) into brackets ⇒ Return line brackets (PDCC) -2-.

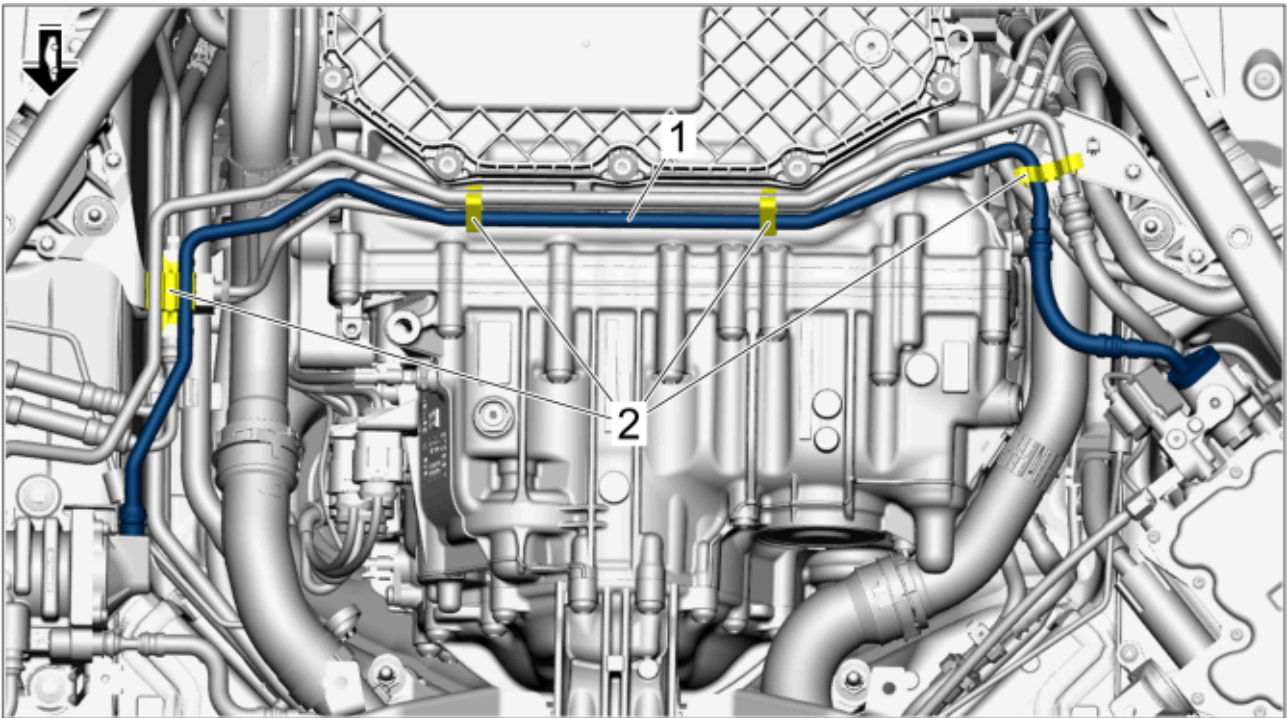

Return line brackets (PDCC)

- 8 Insert the return line (PDCC) ⇒ Return line (PDCC) to pump (PDCC) -1- into the pump (PDCC) ⇒ Return line (PDCC) to pump (PDCC) -3-, screw in a **new** screw ⇒ Return line (PDCC) to pump (PDCC) -2- and secure with the **to a tightening torque of 20 Nm**.

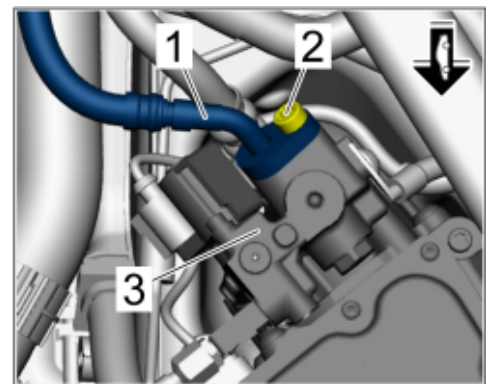

Return line (PDCC) to pump (PDCC)

- 9 Plug return line (PDCC) ⇒ *Return line (PDCC) to valve block (rear) -1-* into valve block (rear) ⇒ *Return line (PDCC) to valve block (rear) -2-*.

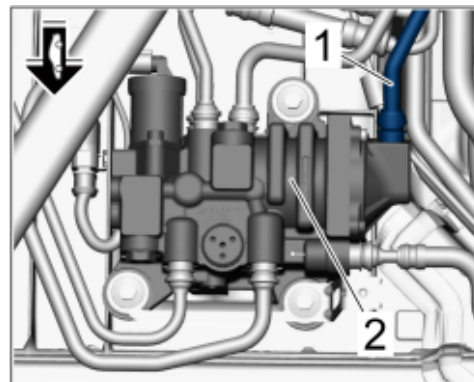

Return line (PDCC) to valve block (rear)

- 10 Check that the hydraulic line (PDCC) is locked correctly.

- 10.1 Ensure that the return line (PDCC) is fully inserted by pulling on it.
- 10.2 Visually check if the red ring is ⇒ *Sample illustration of inserted hydraulic line (PDCC) -1-* visible. If this is the case, the hydraulic line is **not** locked correctly.

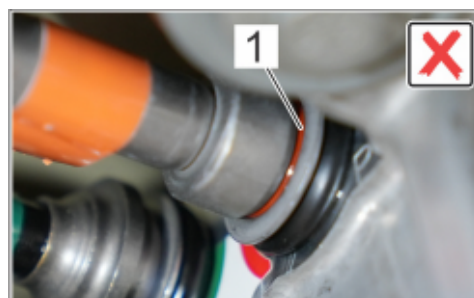

- 11 Fill PDCC (system).
⇒ *Workshop Manual '430317A3 Bleeding and filling PDCC (system)'*

- 12 Installing the support plate.
⇒ *Workshop Manual '421419A1 Removing and installing support plate'*

- 13 Install the rear cover.
⇒ *Workshop Manual '519419A4 Removing and installing rear cover'*

- 14 Activate the high-voltage system.
⇒ *Workshop Manual '277583A3 Deactivating and activating high-voltage system'*

- 15 Enter the campaign in the warranty and maintenance logbook.



Sample illustration of inserted hydraulic line (PDCC)

Warranty processing**Information**

The specified labor times were determined specifically for carrying out this campaign and include all of the necessary preliminary and subsequent rework. The labor times can differ from the labor time published in the Labor Operation List in the PCSS.

Scope 1: **Checking the return line (PDCC)****Labor time:**

Checking the return line (PDCC)

Labor time: **88 TU**

Includes:

Removing and installing the rear cover

⇒ **Damage number WSS0 066 000 1**Scope 2: **Checking and replacing the return line (PDCC)****Labor time:**

Checking and replacing the return line (PDCC)

Labor time: **304 TU**

Includes: Deactivate and activate high-voltage system
Bleeding and filling PDCC (system)
Removing and installing support plate

Required parts:

V04015010S	Return line – PDCC system	1 piece
N 10517304	Cheese head bolt with multiple-tooth head, self-locking M8 x 22 – Return line on pump (PDCC)	1 piece

Required materials (usually already available in the Porsche Center):

00004330574	Hydraulic oil 1 liter/ 33.8 fl oz container – PDCC system	2 piece
-------------	--	---------

⇒ **Damage code WSS0 066 000 2**

Important Notice: Technical Bulletins issued by Porsche Cars North America, Inc. are intended only for use by professional automotive technicians who have attended Porsche service training courses. They are written to inform those technicians of conditions that may occur on some Porsche vehicles, or to provide information that could assist in the proper servicing of a vehicle. Porsche special tools may be necessary in order to perform certain operations identified in these bulletins. Use of tools and procedures other than those Porsche recommends in these bulletins may be detrimental to the safe operation of your vehicle, and may endanger the people working on it. Properly trained Porsche technicians have the equipment, tools, safety instructions, and know-how to do the job properly and safely. Part numbers listed in these bulletins are for reference only. The work procedures updated electronically in the Porsche PIWIS diagnostic and testing device take precedence and, in the event of a discrepancy, the work procedures in the PIWIS Tester are the ones that must be followed.

© 2026 Porsche Cars North America, Inc.