

ATTENTION:

- GENERAL MANAGER
- PARTS MANAGER
- CLAIMS PERSONNEL
- SERVICE MANAGER

IMPORTANT - All Service Personnel Should Read and Initial in the boxes provided, right.

© 2025 Subaru of America, Inc. All rights reserved.



QUALITY DRIVEN® SERVICE

PRODUCT CAMPAIGN BULLETIN

APPLICABILITY: 2023-2025 MY Solterra

NUMBER: WRD-25R

DATE: 09/12/25

SUBJECT: Safety Recall and Stop Sale: Solterra HVAC ECU Reprogramming

REVISED: 03/03/26

NHTSA ID: 25V577

Subaru of America, Inc. (Subaru) has initiated a safety recall for certain 2023-2025 model year Solterra Vehicles to update the HVAC control ECU software.

DESCRIPTION OF THE DEFECT AND SAFETY RISK

The subject vehicles are equipped with Heating, Ventilation, and Air Conditioning (HVAC) systems that, among other things, control the windshield defroster function. Due to the programming of the HVAC control ECU software, under certain conditions, such as a specific failure mode of the electric compressor, the HVAC system will enter a failsafe mode that suspends the heater operation of the system and affects defroster function.

In some cases, when the vehicle is operated in certain low temperatures, the defrosting performance reduces and may not remove frost, ice and/or fog from the windshield glass. This can reduce driver visibility and increase the risk of a crash in certain driving conditions.

REMEDY

Subaru retailers will update the HVAC control ECU software at no cost to the customer. For customer satisfaction, dealers will inspect and, if necessary, replace the electrical compressor free of charge. Due to current part inventory, stop sale vehicles requiring electrical compressor replacement will be withheld from completion until part supply becomes sufficient and the service procedure provided in this bulletin is revised.

AFFECTED VEHICLES

A total of 32,320 U.S. vehicles will be included in this safety recall as listed below. Not all vehicles in the production range listed are affected by this recall. Coverage must be confirmed by using the Vehicle Coverage Inquiry function on subarunet.com prior to repair.

Model Year	Carline	Production Date Range
2023-2025	Solterra	March 29, 2022 – June 3, 2025

CAUTION: VEHICLE SERVICING PERFORMED BY UNTRAINED PERSONS COULD RESULT IN SERIOUS INJURY TO THOSE PERSONS OR TO OTHERS.

Subaru Service Bulletins are intended for use by professional technicians ONLY. They are written to inform those technicians of conditions that may occur in some vehicles, or to provide information that could assist in the proper servicing of the vehicle. Properly trained technicians have the equipment, tools, safety instructions, and know-how to do the job correctly and safely. If a condition is described, DO NOT assume that this Service Bulletin applies to your vehicle, or that your vehicle will have that condition.

Subaru of America, Inc. is ISO 14001 Compliant

ISO 14001 is the international standard for excellence in Environmental Management Systems. Please recycle or dispose of automotive products in a manner that is friendly to our environment and in accordance with all local, state and federal laws and regulations.

Continued...

RETAILER RESPONSIBILITY

Please be advised that it is a violation of Federal law for a dealer to deliver a new motor vehicle covered by a recall under a sale or lease until the defect is remedied. Therefore, any Authorized Subaru Retailer failing to perform the applicable service procedures to correct all affected vehicles in their inventory prior to the vehicle being placed in service may be subject to civil penalties of up to \$27,874 per violation (i.e., for each vehicle), as provided in 49 CFR §578.6 and will also be in breach of the Subaru Dealer Agreement.

Any vehicles listed in any recall/campaign that are in retailer stock must be:

- Immediately identified
- Tagged or otherwise marked to prevent their delivery or use prior to repair
- Repaired in accordance with the repair procedures outlined in the Product Campaign Bulletin

Retailers are to promptly perform the applicable service procedures, to correct all affected vehicles in their inventory (used, demo & SSLP). Whenever a vehicle subject to this recall is taken into retailer inventory necessary steps should be taken to ensure the recall correction has been made before selling or releasing the vehicle.



OWNER NOTIFICATION

Subaru will notify affected vehicle owners by first class mail within 60 days. Retailers will be advised when owner notification is scheduled.

PART INFORMATION:

A part kit for vehicles requiring electrical compressor replacement is currently in development. Information regarding order placement will be provided once made available.

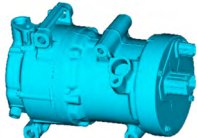
[Note: If a compressor kit is needed, follow the parts release process outlined below the service procedure.](#)

Part Description	Part Number	Qty	Image
WRD-25 COMPRESSOR KIT	0400530242	1	
COMPRESSOR ASSY, W/M		1	
RECEIVER ASSY		1	
O-RING		2	O-RING Dimensions ID : 13.4mm / OD : 18.2mm
O-RING		2	O-RING Dimensions ID : 17.2mm / OD : 22.0mm
O-RING		3	O-RING Dimensions ID : 10.8mm / OD : 15.6mm
O-RING		2	O-RING Dimensions ID : 6.7mm / OD : 10.3mm

Continued...



.CUW FILE INFORMATION:

The following files can be located in the ECU Data folder within the TechStream files located on the Subaru Desktop.







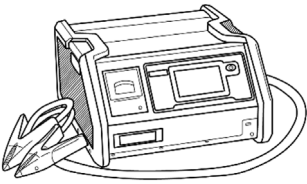





MY	File Description	Target CID	New CID
23	NA(23MY)_8865F4216000.cuw	8865F4213100	8865F4216000
24-25	NA(24-25MY)_8865F4228100.cuw	8865F42220A0 or 8865F4228000	8865F4228100

REQUIRED TOOLS FOR REPROGRAMMING:

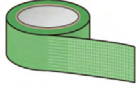
Tool Description	Applications	Image
Laptop DST-i or DST-010	For DTC inspection and Reprogramming	
GTS+		
< MIDTRONICS > DCA-8000	Required to maintain battery voltage during the reprogram- ming procedure	

Continued...

REQUIRED TOOLS FOR A/C COMPRESSOR REPLACEMENT (IF REQUIRED):

Tool Description	Applications	Image
Refrigerant Recovery and Filling Device (compatible with 1234yf)	For air conditioner gas recovery and refilling	
Air conditioner gas leak tester	Inspect for refrigerant leak	
Insulated Tool Set and Insulated Gloves	For working with high-voltage components	
Circuit Tester	For checking voltage	
Insulating tape	For connector protection	
Protective Tape	For protecting parts	
Torque Socket Wrench E8	For removing / installing compressor	
Cable Tie	For holding parts (20-30cm)	
Cloths	For cleaning	
Protective Equipment	For protecting hands and eyes	
General Tools	For work purposes	
Torque Wrench	Check tightening torque	

Continued...

SERVICE PROCEDURE FLOW CHART:

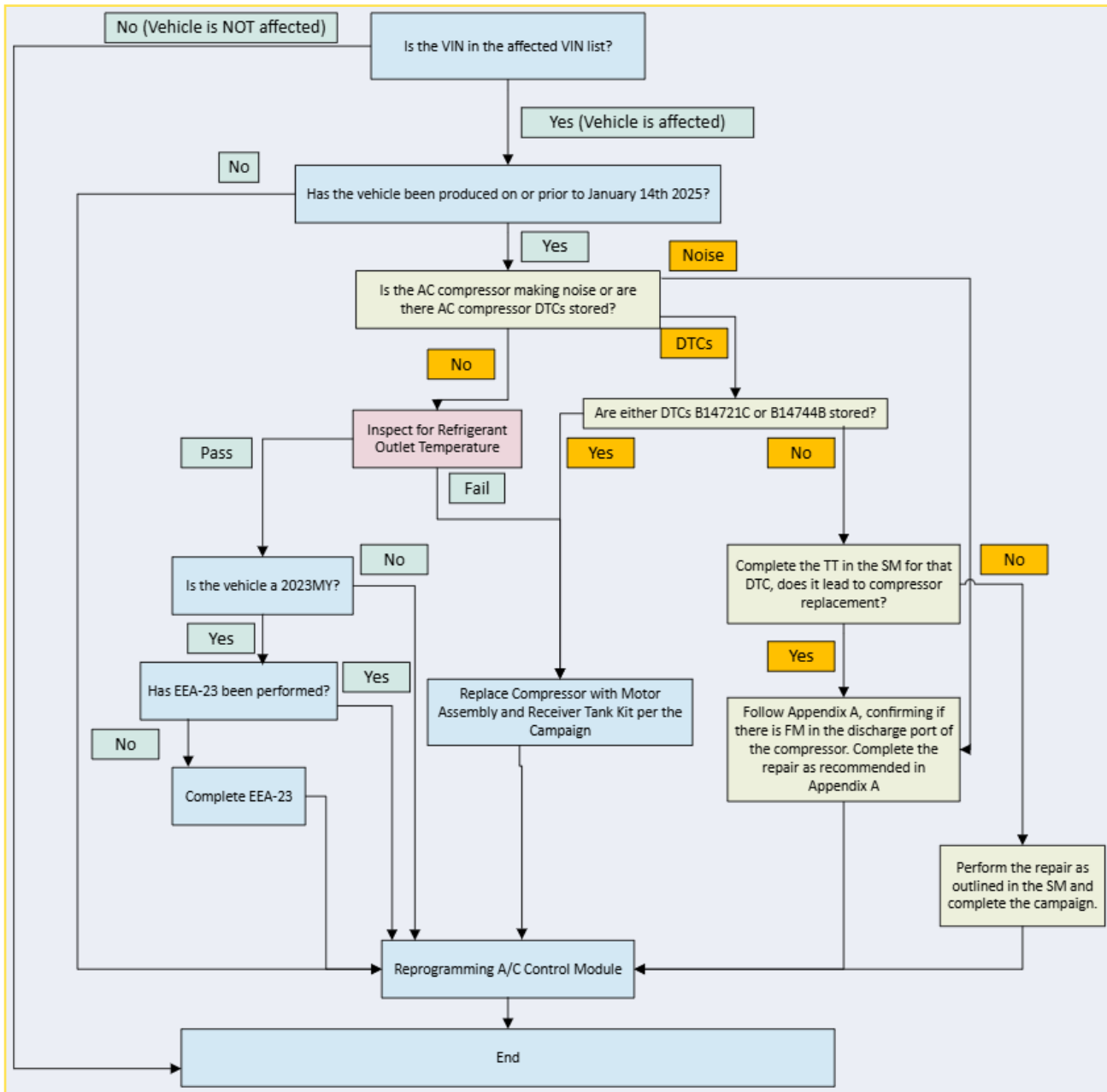

NOTE: PRIOR to attempting any reprogramming, complete all required inspection and where necessary related repairs outlined in the above flow chart. 2023MY vehicles MUST require the software outlined in EEA-23 to be installed prior to reprogramming. ALWAYS confirm the target CID prior to reprogramming.

Continued...

COMPONENT LOCATION:

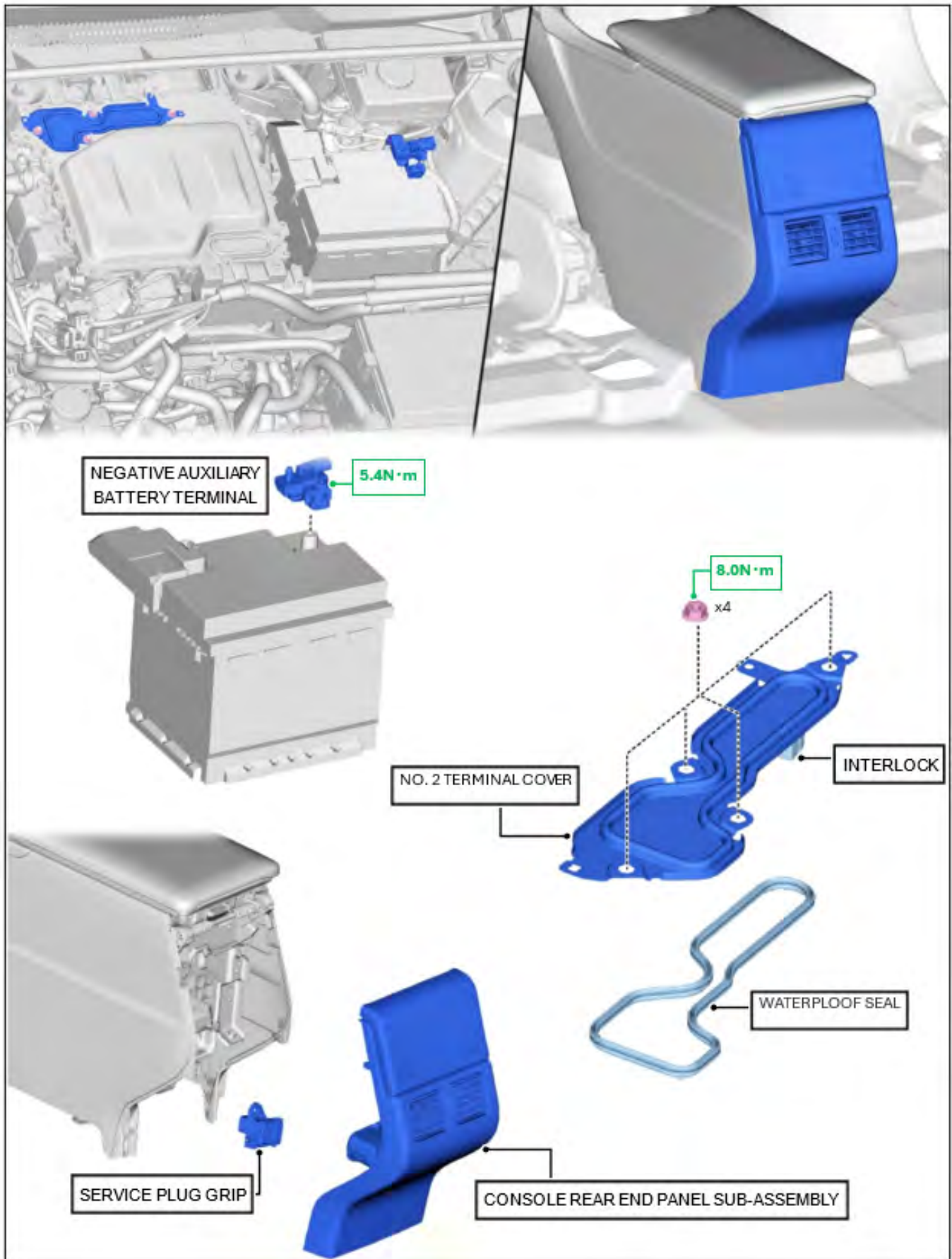

Continued...

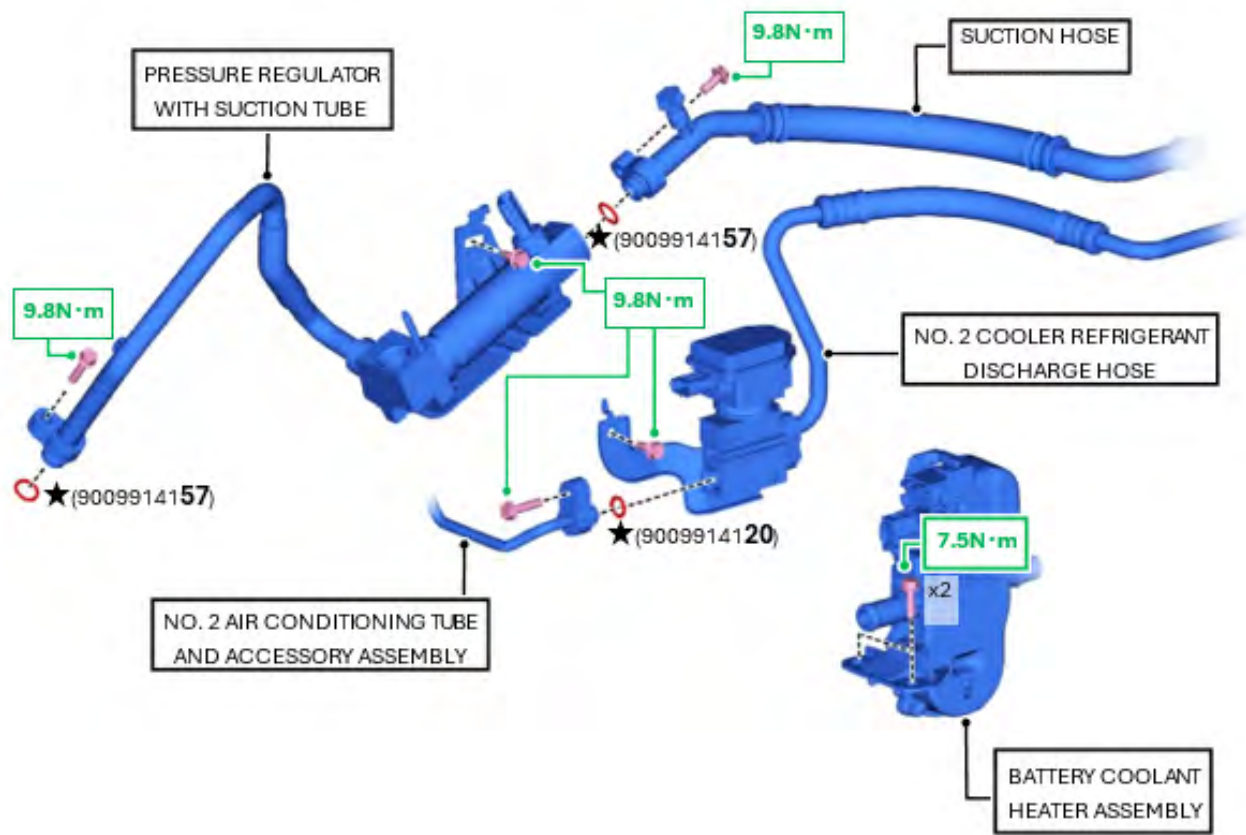
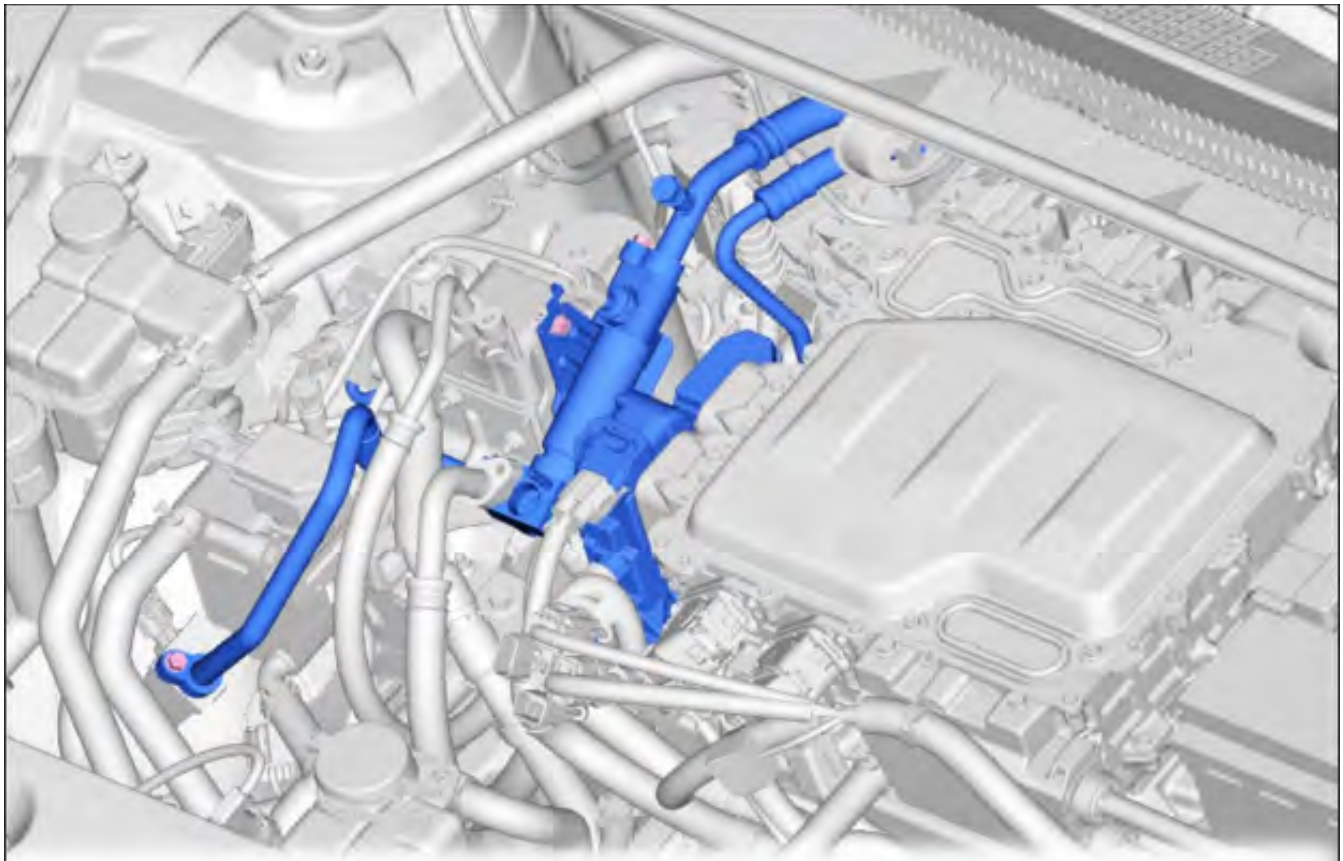

Continued...

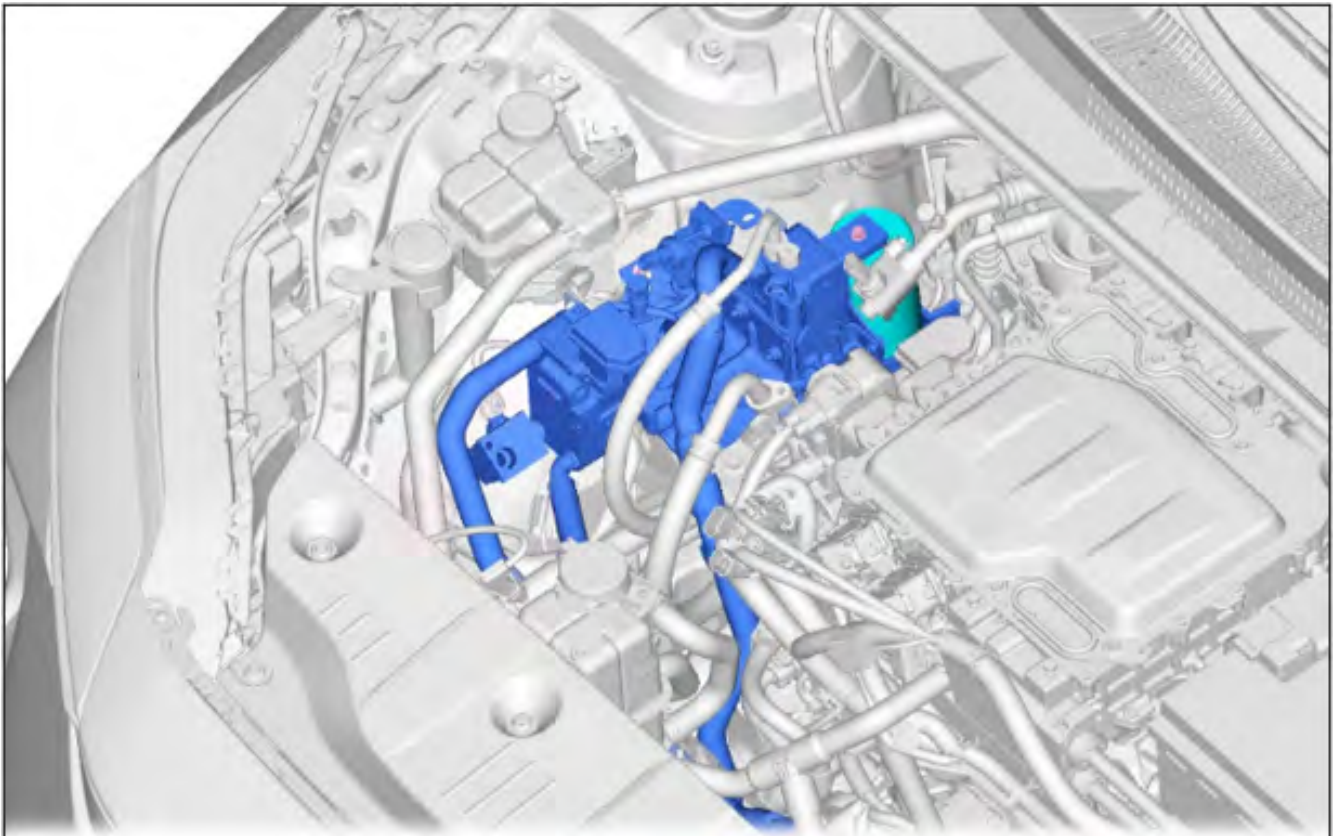

CONDENSER ASSEMBLY WITH HEAT EXCHANGER UNIT SUB-ASSEMBLY

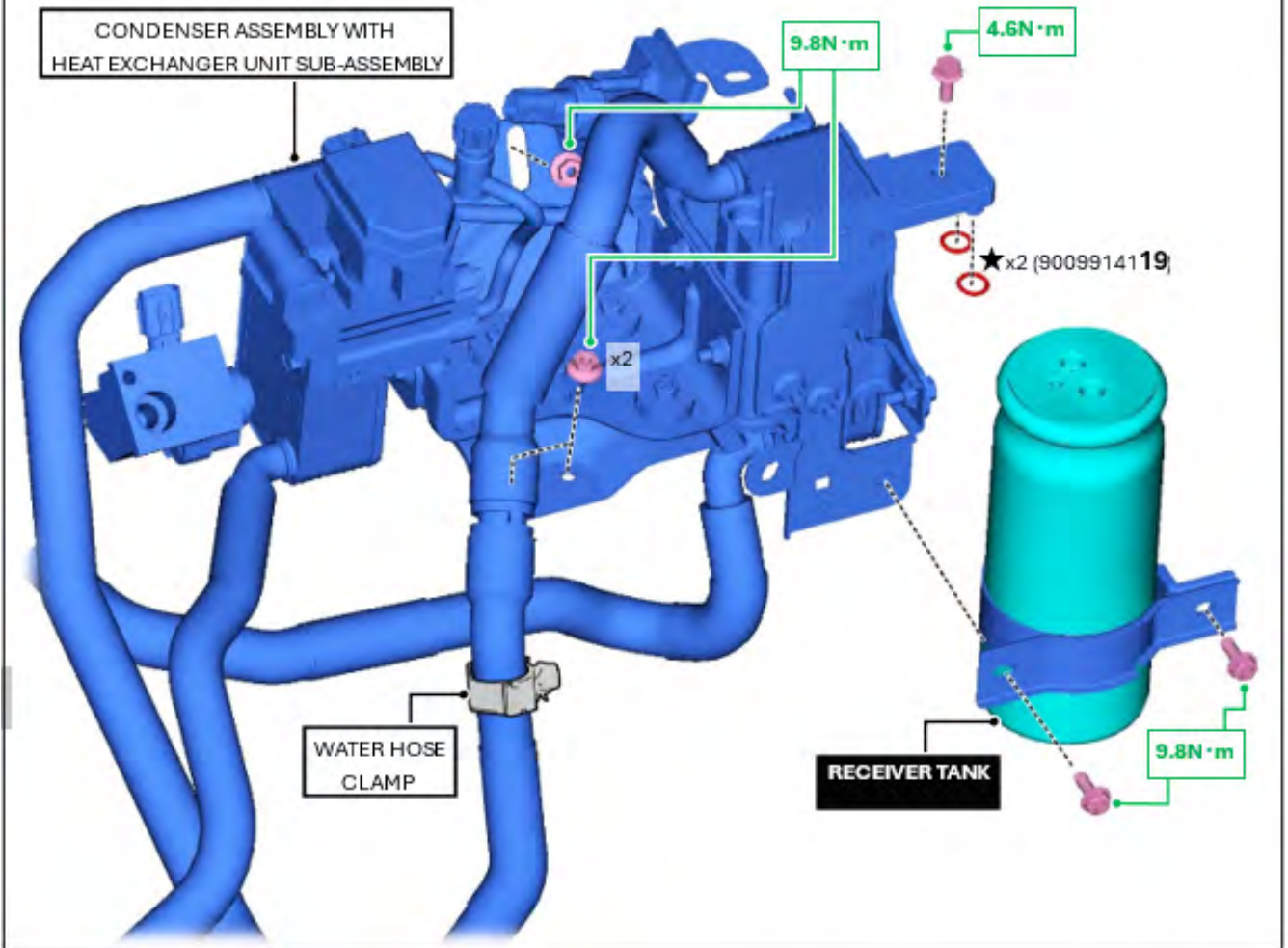

Continued...

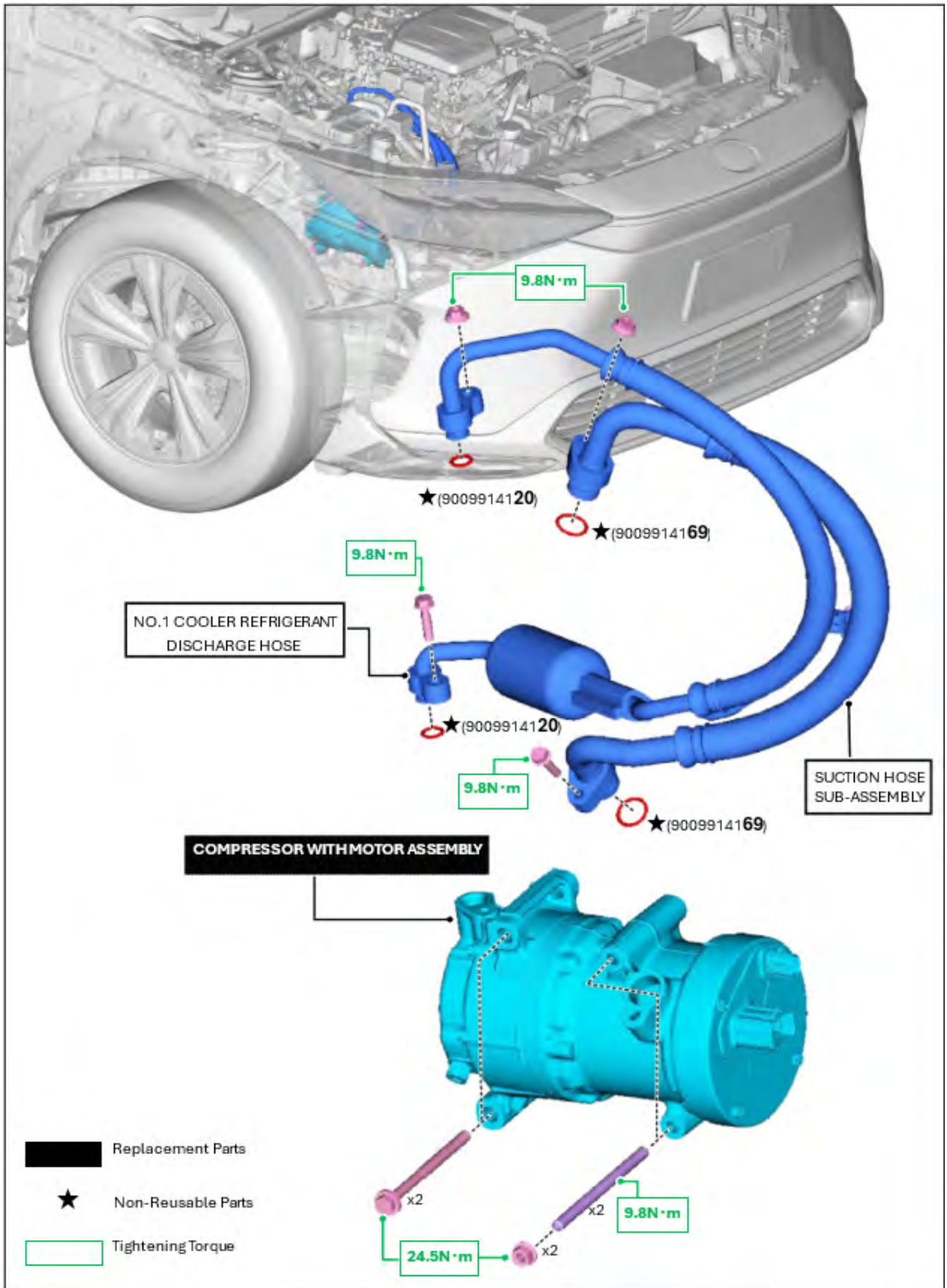

Continued...

SERVICE PROCEDURE:

STEP 1: Has the vehicle been produced on or prior to January 14, 2025? This can be confirmed by the vehicle inquiry.

YES: Proceed to Step 2.

NO: Proceed to Reprogramming File Procedure.

STEP 2: Is the AC compressor making abnormal noise.

YES: Refer to the service procedure in the APPENDIX A section.

NO: Proceed to Step 3.

STEP 3: Perform a Health Check using GTS+. Check for any faults detected by the Air Conditioner system. Refer to the table below to confirm the next course of action.

JUDGMENT CRITERIA		
<p style="text-align: center;">Are any or both of the following DTCs current or stored? DTC : B14721C (A/C Inverter High Voltage Output Circuit Voltage Out of Range) DTC : B14744B (A/C Inverter Cooling/Heating Over Temperature)</p>		
Inspection Result		Next Step
NO	No DTC detected	Proceed to the next step.
NO	DTCs other than B14721C & B14744B	Correct the fault using the procedure supplied in the applicable SM and then proceed to the Reprogramming File Procedure. IMPORTANT: If the diag procedures lead to compressor replacement, refer to the procedure in the APPENDIX A section.
YES	B14721C and/or B14744B detected	Order parts according to the parts ordering process , and perform both the Compressor Motor and Receiver Tank Replacement Procedure and the Reprogramming File Procedure .

STEP 4: Re-check for any other A/C compressor-related DTCs and inspect the A/C compressor for abnormal noises. If any further assistance is require, please prepare the following information and contact Techline.

- Record a video of the noise
- Save a complete GTS+ Health Check
- Save the Trouble Tree results for the related DTCs

Continued...

STEP 5: Confirm the ignition switch is “READY ON”. Check the status of the ambient temperature displayed on the instrument cluster. This temperature will confirm the A/C settings for the required inspection mode performed in the next step.

Outside Temperature	Inspection Mode
Below 77°F (25°C)	A/C OFF
77°F (25°C) or above	A/C ON

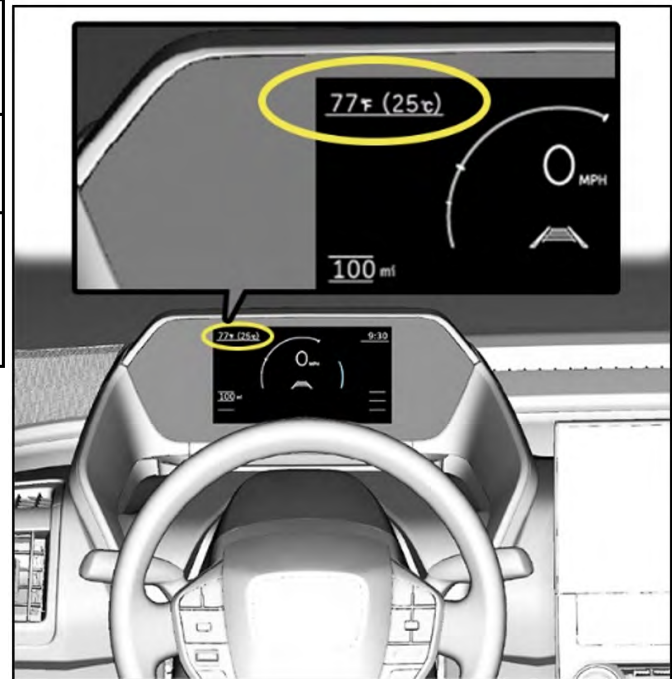

IMPORTANT: Inspection cannot be performed on vehicles stored in an outside temperature of 14°F (-10°C). The inspection mode of the compressor is strongly impacted by temperature. For cases when the vehicle was stored below 14°F (-10°C), the vehicle **MUST** be warmed using the following procedures:

1. Move the vehicle to a location with an ambient temperature higher than 14°F (-10°C).
2. Turn the ignition OFF and wait at least 3 minutes.
3. Disconnect the negative battery terminal.
4. Wait at least 2 minutes.
5. Reconnect the negative battery terminal.
6. Confirm the displayed ambient temperature on the instrument cluster reads above 14°F (-10°C). Repeat this process until the desired temperature is reached prior to proceeding.

Continued...

STEP 6: Using the result from the previous step, confirm and apply the A/C settings required for the inspection mode.

Below 77°F (25°C) (Inspection Mode : A/C OFF)		A/C Settings	77°F (25°C) or above (Inspection Mode : A/C ON)	
ON * After operating to FOOT mode, the indicator turns off.		AUTO		ON * After operating to FOOT mode, the indicator turns off.
OFF		A/C		ON
FOOT		Airflow mode control		FOOT
OUTSIDE		Outside/recirculated air mode		INSIDE
MAX HOT		Temperature control (Both drivers and passenger seat)		MAX HOT
DO NOT TOUCH	/	Fan Speed	/	DO NOT TOUCH
OFF		ECO		OFF
ON		SYNC		ON
OFF		S-FLOW		OFF
READY ON	/	Ignition Switch	/	READY ON
CLOSE ALL	/	Window / Door	/	CLOSE ALL



NOTE: If you change the Airflow mode control to FOOT after operating the AUTO switch, the AUTO switch operation indicator light will turn off, but you will need to operate the AUTO switch to operate the Fan Speed with automatic setting.

CAUTION:

- Confirm the correct A/C settings are applied to confirm an accurate inspection.
- Even if the A/C indicator is off, the A/C may still be operating. If you need to turn it off, first turn the A/C on and then turn it off.
- Even if the displayed temperature is below 77°F (25°C), if the vehicle protection control indicates a situation where the actual rotation remains at 0 rpm and below 1000 rpm for 30 seconds after the active test shows 5200 rpm, perform the A/C under conditions of 77°F (25°C) or higher.
- **DO NOT** perform any reprogramming prior to performing the inspection mode. The new software will cause inaccurate results.

Continued...

STEP 7: Using the GTS+, click on “Air Conditioner” located in the “System Select” column.

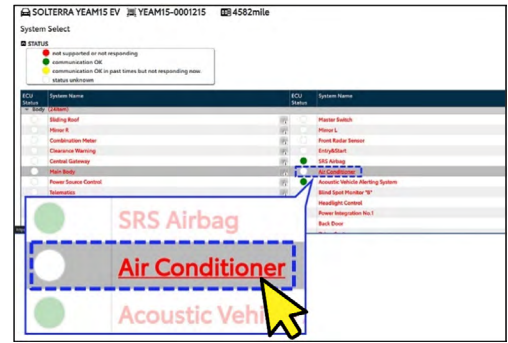

STEP 8: Click on “Active Test” and “Compressor Target Speed”. Click the “Next” button to continue.

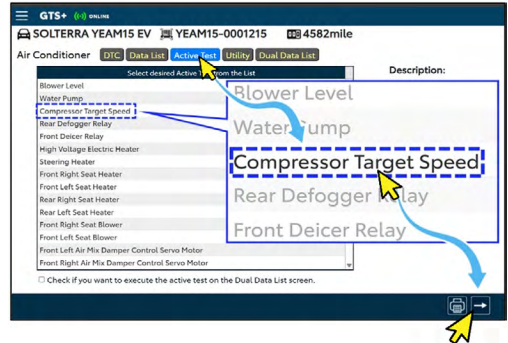

STEP 9: Using the adjustment buttons, set the compressor target speed to 5200.

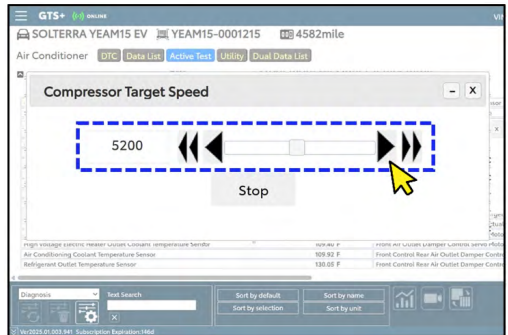

STEP 10: Select the item from “Diagnosis” to “All Data”.

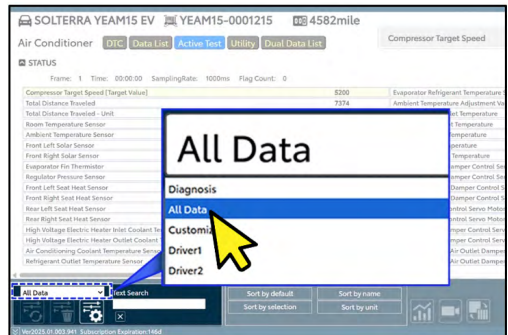

STEP 11: Select “Refrigerant Outlet Temperature Sensor” & “Compressor Actual Speed” then click the “Graph” button to continue.

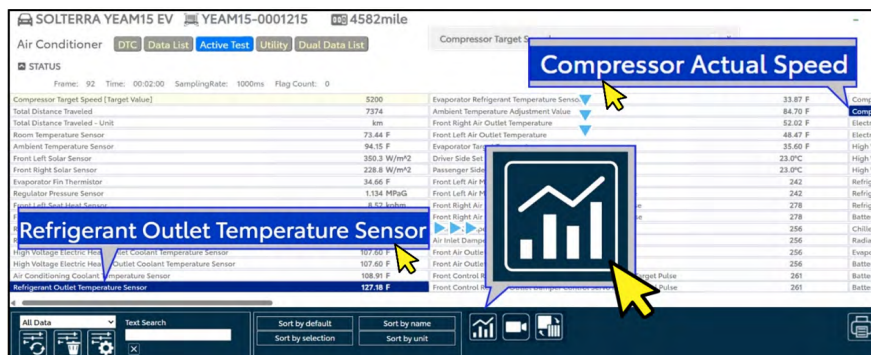

Continued...

STEP 12: Click the “Snapshot” button then click the “Snapshot Configuration” button. Set the duration to ten minutes. Click the “OK” button to continue.

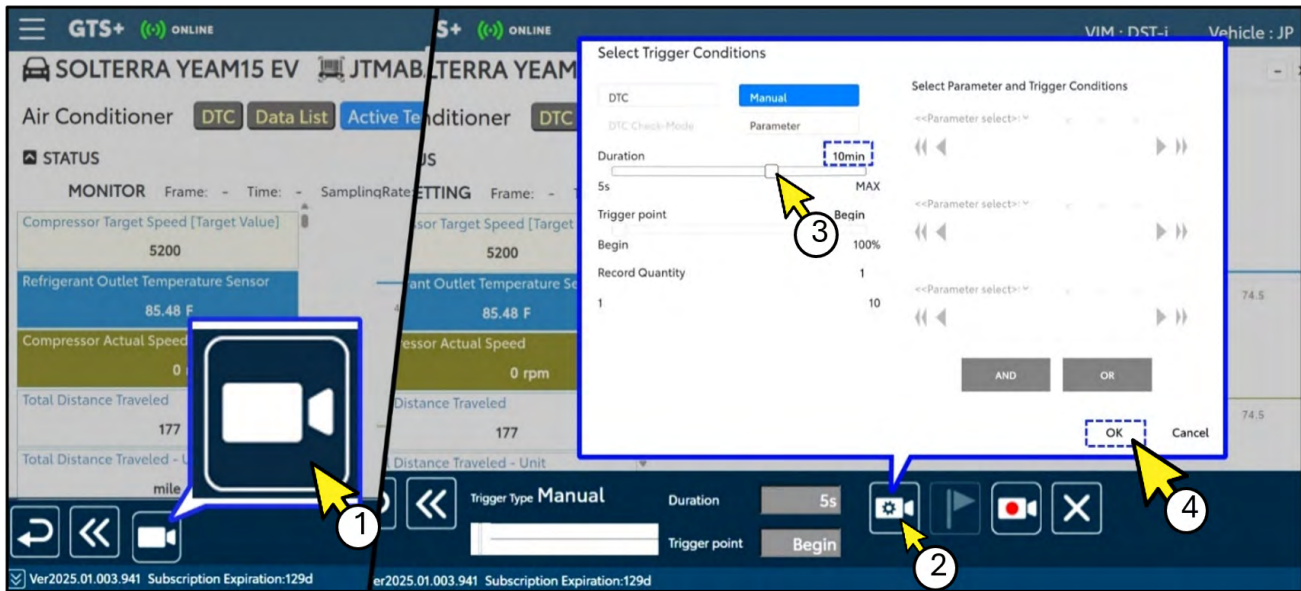

1. Snapshot Button
2. Snapshot Configuration Button
3. Duration Adjustment
4. OK Button

STEP 13: Click the “Record” button. Allow the ten minute recording to begin. Allow the ten minute time period for recording.

CAUTION: If the outside temperature displayed on the meter is below 77°F (25°C) and the inspection mode is set to “Air Conditioner OFF,” check the “Actual Electric Compressor RPM” again before recording. If it is still within the 0-1000 rpm range after 30 seconds, switch the inspection mode to “Air Conditioner ON,” just as if the temperature were 77°F (25°C).

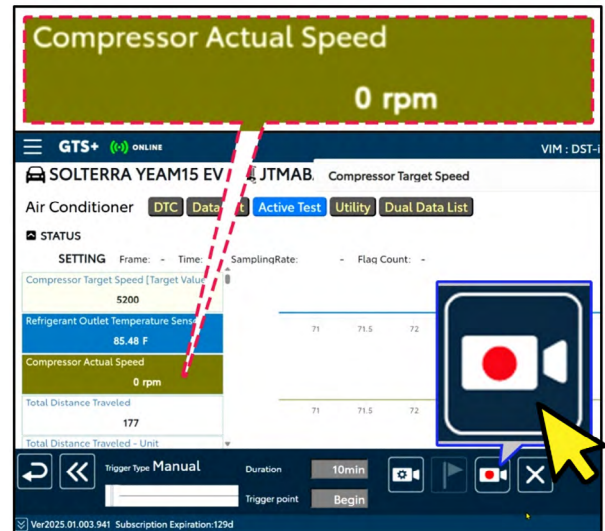

NOTE: If the graph does not appear, click the graph setting icon and change the Y-axis to “AUTO”.

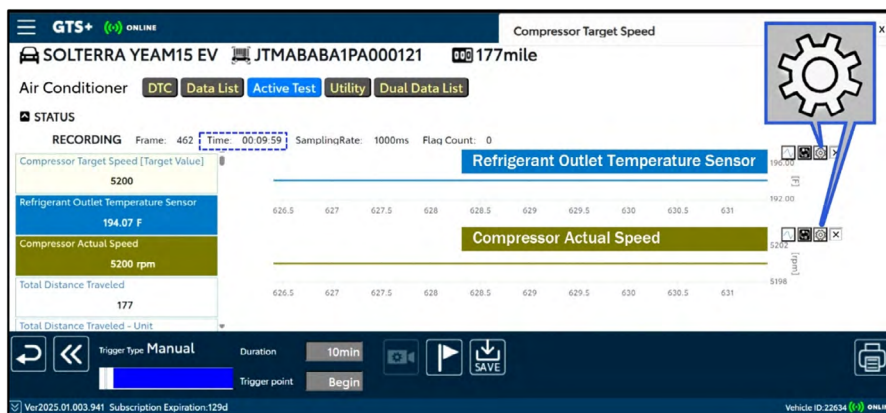

Continued...

STEP 14: After the ten minute recording has been completed, a pop-up will display asking if the data is to be saved. Click “Yes”, select a destination for the data, and click “OK”. Once saving is completed, click “OK” to continue.

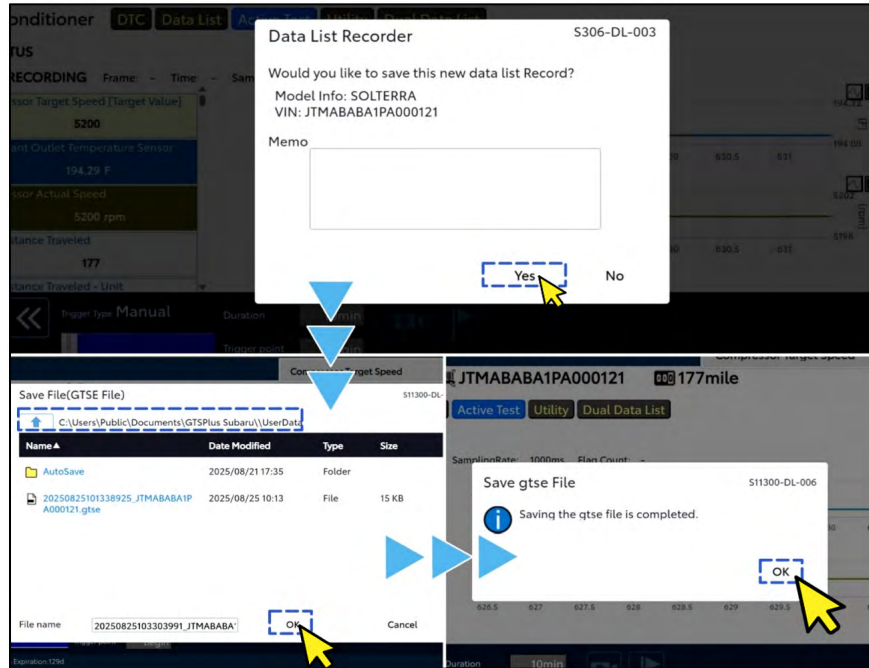

STEP 15: Select “Exit to Home” located in the top left corner of the GTS+ application. The home screen will then be displayed. Select the “Open Scan Data File” icon.



Select the saved file and click “OK” to continue.

NOTE: The file size, date, and time can help ensure the correct file is selected.

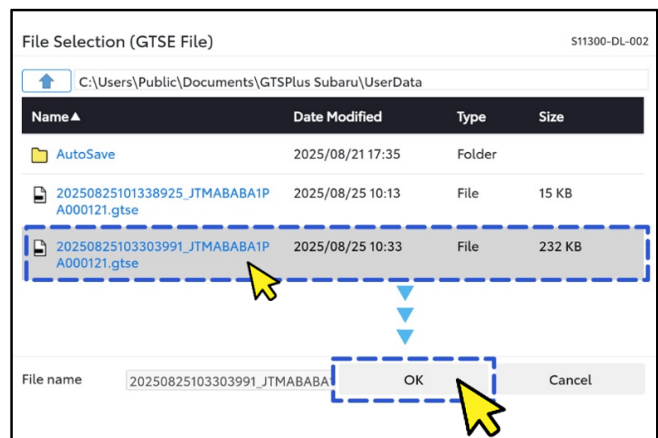

Continued...

STEP 16: Click the file icon located in the upper left corner. Open “Air Conditioner” and then “Active Test”. Click the saved data.

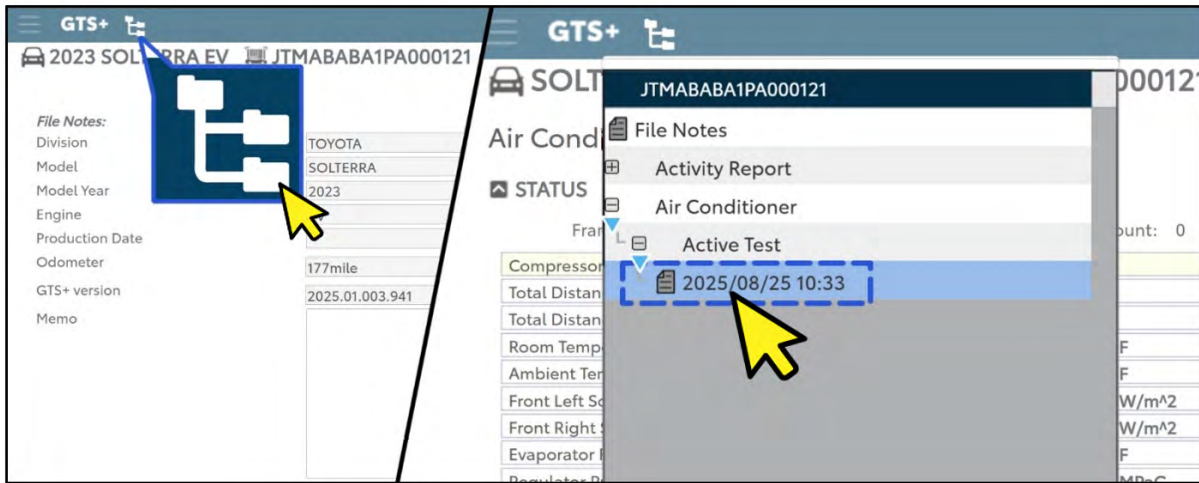

STEP 17: Select “Refrigerant Outlet Temperature Sensor” and then click the “Graph” button. This will allow the ten minute recording to be viewed.

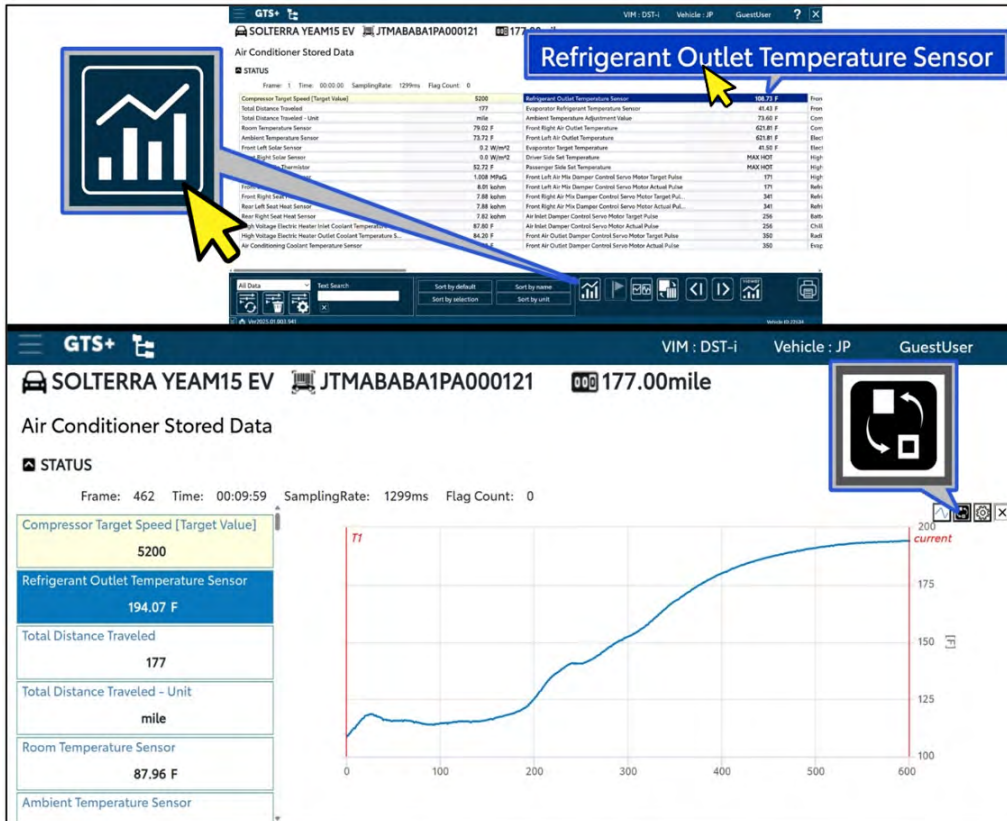

NOTE: If the outside temperature is under 77°F (25°C) and the inspection mode is A/C OFF, click “Change graph” and change the display format to “Meter” to make it easier to determine the maximum temperature.

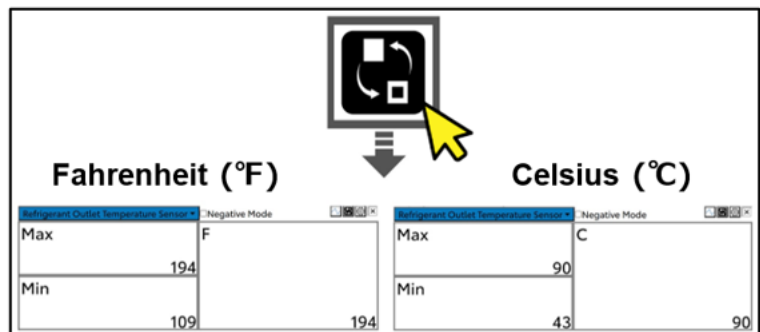

Continued...

STEP 18: Check the refrigerant outlet temperature and determine if the compressor requires replacement. Refer to the tables below.

CAUTION: The method for checking data differs depending on the inspection mode with the A/C on or off. This selection is based on the ambient air temperature confirmed in step 3.

JUDGMENT CRITERIA	
Inspection Mode	Inspection Method
<p>Over 77°F (25°C) A/C ON</p>	<p>Confirm Refrigerant Outlet Temperature after 5 to 10 minutes.</p>
<p>Didn't the Refrigerant Outlet Temperature reach 230°F (110°C) after 5 to 10 minutes?</p>	
Inspection Result	Next Step
<p>OK</p> <p>After 5-10 minutes the temperature never reached 230°F (110°C).</p>	<p>Proceed to reprogramming</p>
<p>YES</p> <p>After 5-10 minutes the temperature was over 230°F (110°C).</p>	<p>Proceed to A/C Compressor Motor & Receiver Tank replacement</p>

Continued...

JUDGMENT CRITERIA	
Inspection Mode	Inspection Method
Under 77°F (25°C) A/C OFF	Confirm Refrigerant Outlet Temperature for 10 minutes.
Didn't the Refrigerant Outlet Temperature reach 239°F (115°C) within 10 minutes?	
Inspection Result	Next Step
<div style="background-color: green; color: white; padding: 10px; text-align: center; font-size: 2em; font-weight: bold;">OK</div> <p>The temperature never reached 239° (115°C)F in 10 minutes.</p>	Proceed to reprogramming
<div style="background-color: red; color: white; padding: 10px; text-align: center; font-size: 2em; font-weight: bold;">YES</div> <p>Within 10 minutes the temperature reached 239°F (115°C).</p>	Proceed to A/C Compressor Motor & Receiver Tank replacement

COMPRESSOR MOTOR AND RECEIVER TANK REPLACEMENT PROCEDURE

STEP 1: RECOVERY OF REFRIGERANT

(1) Turn READY ON and operate the compressor under the conditions shown below.

NOTE: This will collect most of the compressor oil from the various components of the air conditioning system into the compressor, but, if the compressor is faulty, skip this step and go to the next step.

Contents	Condition
Operating time	3 minutes or more
Temperature setting	Max cool
Blower speed	High
Ignition Switch	READY ON
A/C switch	ON

Continued...

(2) Turn the ignition switch off.

(3) Recover the refrigerant from the A/C system using a refrigerant recovery unit.

Caution: Do not release the refrigerant into the atmosphere when discharging it. Please ensure that it is collected so that it can be reused when refilling.

Note: Use the refrigerant recovery device in accordance with the manufacturer's instruction manual.

STEP 2: DISCONNECT NEGATIVE TERMINAL FROM AUXILIARY BATTERY

(1) Loosen the nut and disconnect the cable from the negative terminal of the auxiliary battery.

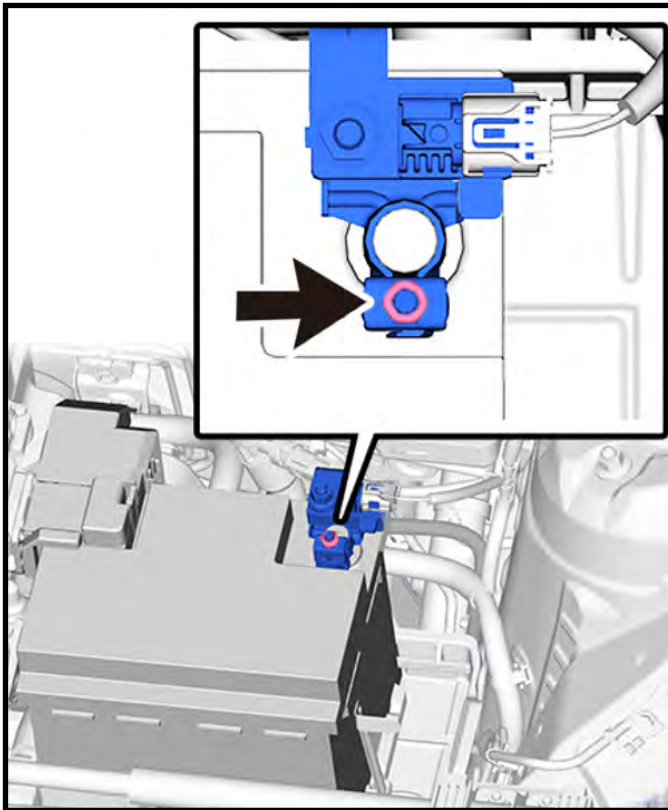

Caution:

- To record the various memories and settings of the navigation system, wait at least 3 minutes after turning the IG OFF before disconnecting the negative battery terminal.
- Check in advance whether the security lock setting is enabled.
- Depending on your multi-display settings, IG may continue to operate in the background even if you select IG OFF, so be sure to check the "ACC customize" settings beforehand.

Service Manual reference

Audio / Visual / Telematics > AUDIO / VIDEO > NAVIGATION / MULTI INFO DISPLAY > NAVIGATION SYSTEM > PRECAUTION

STEP 3: REMOVE CONSOLE REAR END PANEL SUB-ASSEMBLY

(1) Apply protective tape around the upper part of console rear end panel sub-assembly as shown in the illustration.

(2) Disengage the claws and clips to remove the console rear end panel sub-assembly.

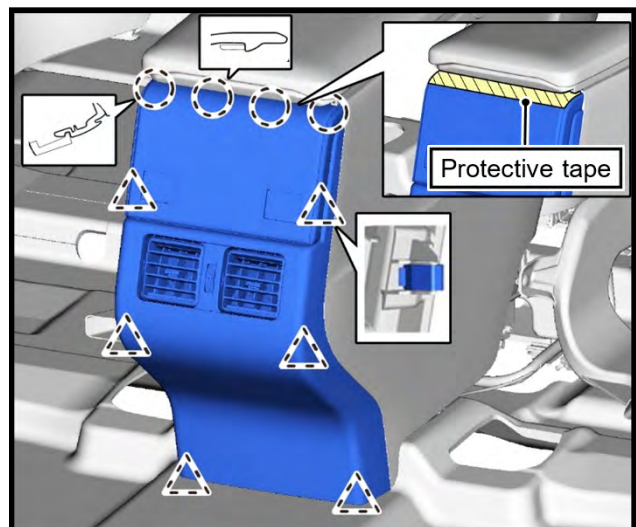

Continued...

STEP 4: REMOVE SERVICE PLUG

Caution:

- Wear insulated gloves when working.
- Do not inspect or maintain the high-voltage system while the service plug grip is attached.
- To reduce the risk of electric shock, remove the service plug grip and disconnect the high-voltage circuit before performing vehicle maintenance.
- After removing the service plug grip, wait at least 10 minutes for the high-voltage capacitor to fully discharge.
- Turning the ignition switch to READY ON after removing the service plug grip may cause malfunction. Do not turn the ignition switch to READY ON unless instructed to do so in the service manual.
- Do not touch the terminals of the service plug grip.
- Replace the service plug grip if it has been subjected to impact or dropped.

(1) Wearing insulating gloves, pull out the service plug grip following the procedure shown in the illustration.

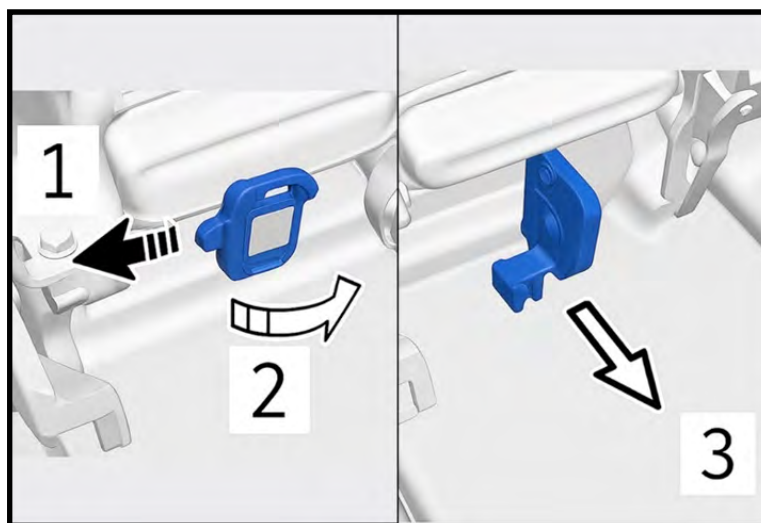

STEP 5: CHECK TERMINAL VOLTAGE

(1) Remove the four nuts and remove the No. 2 terminal cover.

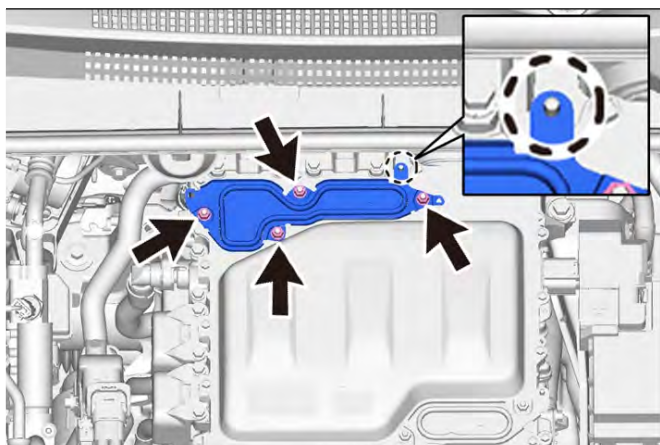

Caution:

- Use insulated tools and gloves when working.
- Do not touch the No. 2 terminal cover waterproof seal.
- Do not allow any foreign matter or water to enter the electric converter unit assembly.

Continued...

(2) Check the terminal-to-terminal voltage of the high-voltage DC line. **Standard Voltage: 0V**

Note: Use a measuring range of DC 750 V or more on the voltmeter.

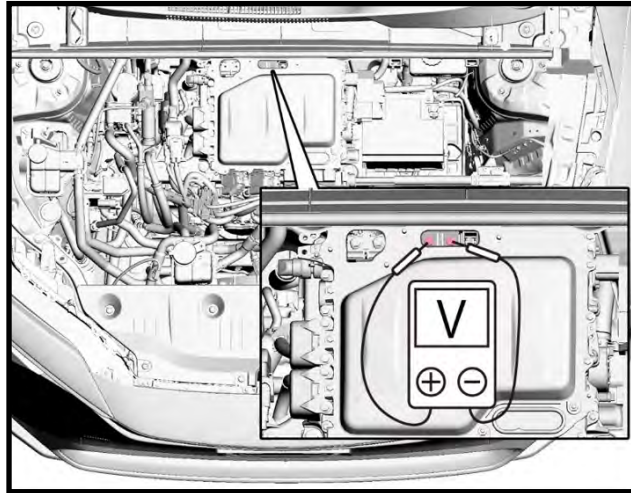

(3) Attach NO. 2 terminal cover to the electrical converter unit assembly and tighten the four nuts in the order shown in the figure to secure it in place. Tightening torque: 8.0N·m

Caution: Before installing, make sure that the waterproof seal and interlock are properly attached to the back of the NO 2 terminal cover.

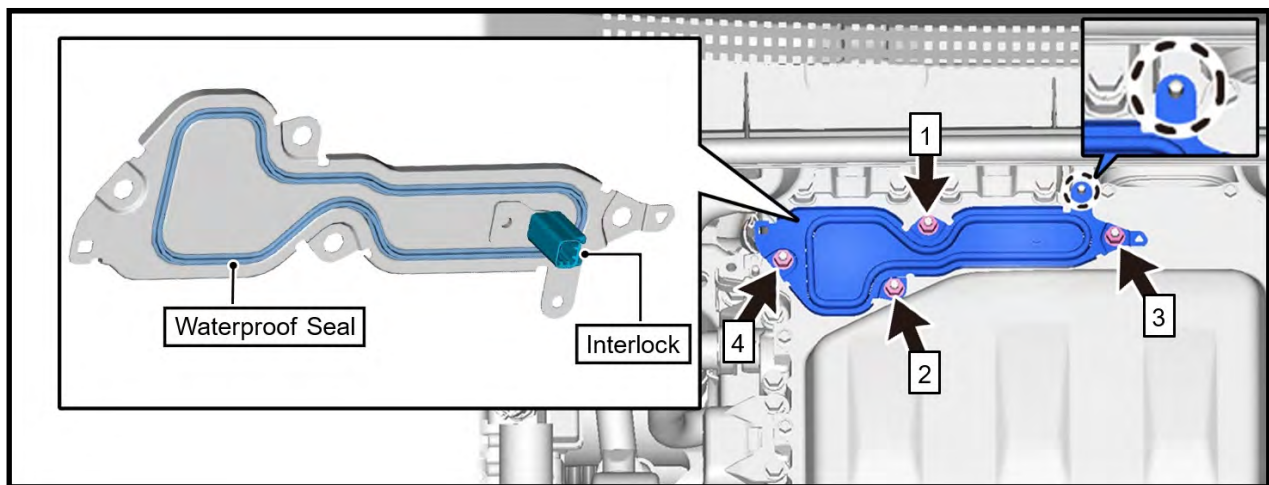

STEP 6: REMOVE UPPER PART OF SUCTION HOSE SUB-ASSEMBLY

CAUTION:

- Do not use power tools or air tools to remove air conditioning piping.
- When disconnecting the air conditioning system piping, cover it with a cloth to prevent the oil accumulated inside the piping from scattering.
- Unlike the service manual, the work is performed without draining the coolant.

(1) Remove the nut and remove the upper part of the suction hose sub-assembly.

(2) Remove the O-RING from the suction hose sub-assembly and discard it as non-reusable.

Caution: Seal the separated parts with vinyl tape to prevent foreign matter and water from entering.

Continued...

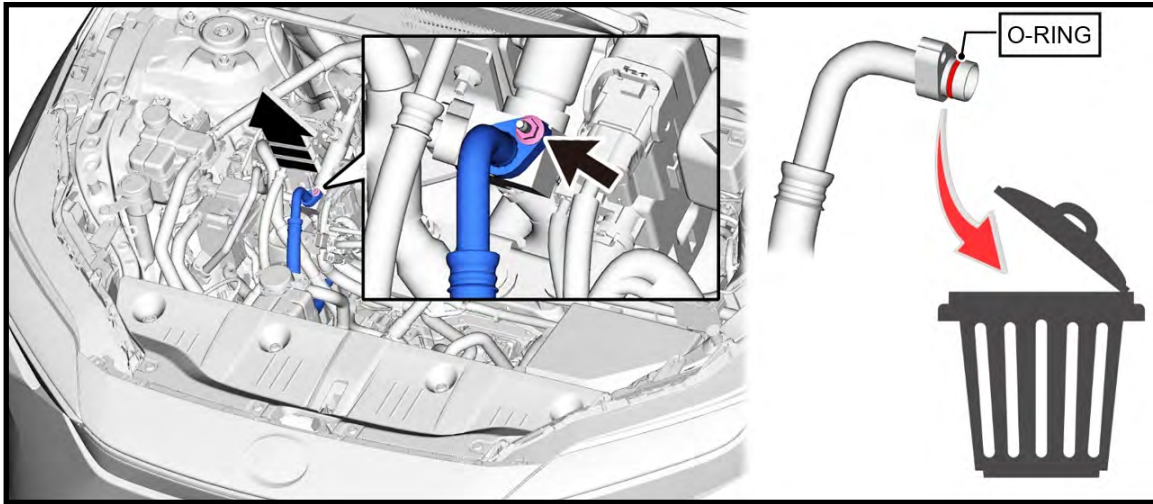

STEP 7: REMOVE UPPER PART OF NO. 1 COOLER REFRIGERANT DISCHARGE HOSE

- (1) Remove the nut and disconnect the upper part of the cooler refrigerant discharge hose No. 1.
- (2) Remove the O-RING from the No. 1 cooler refrigerant discharge hose and discard it as non-reusable.

Caution: Seal the separated parts with vinyl tape to prevent foreign matter and water from entering.

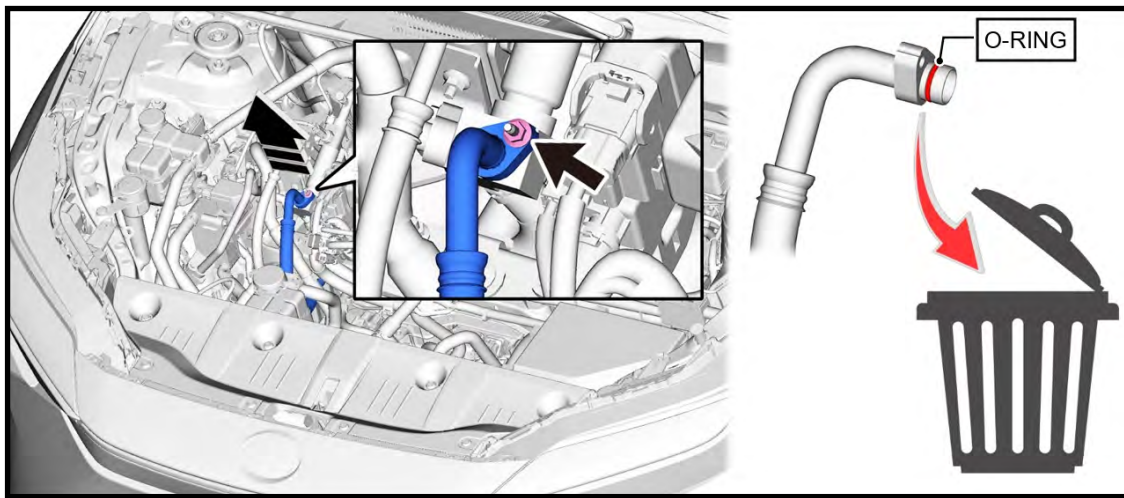

STEP 8: SEPARATE WATER HOSE ASSEMBLY

- (1) Release the upper and lower locks on the clamp and remove the water hose sub-assembly from the clamp so that it can be moved.

Note: The clamp remains on the vehicle.

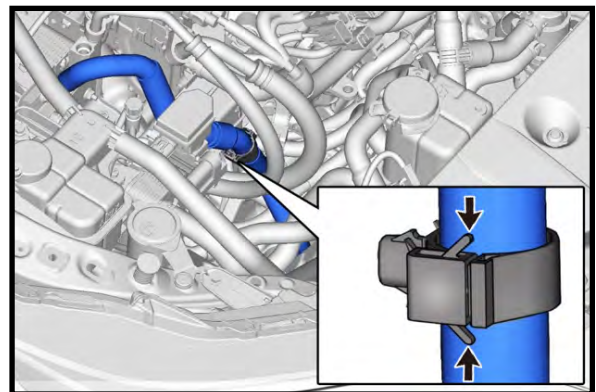

Continued...

STEP 9: SEPARATE BATTERY COOLANT HEATER ASSEMBLY

(1) Remove the two bolts and to allow movement of the battery coolant heater assembly.

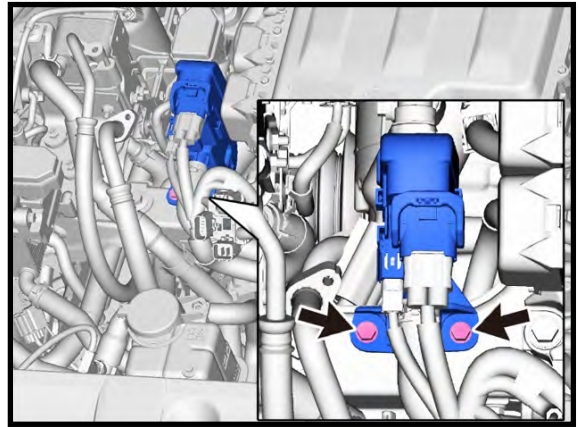

STEP 10: REMOVE PRESSURE REGULATOR WITH SUCTION TUBE

(1) Remove the connector and three bolts.

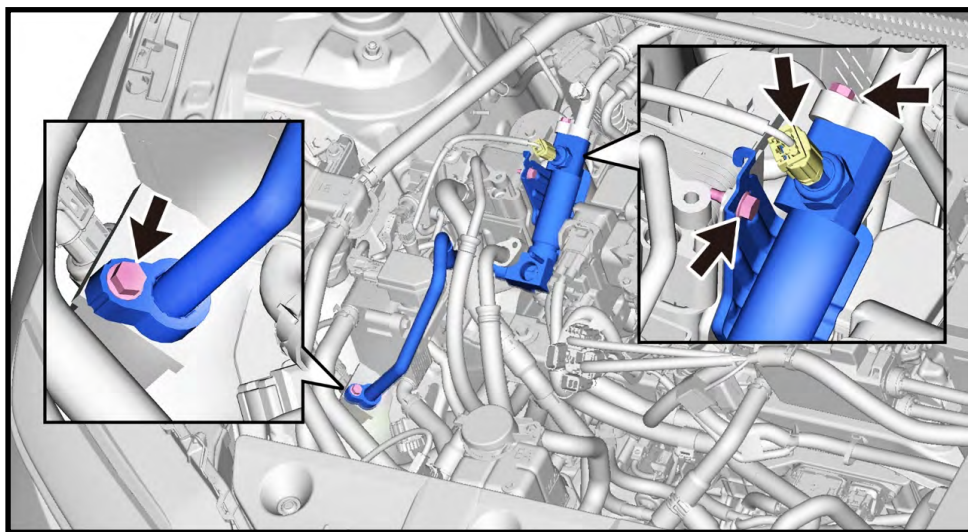

(1) Remove the pressure regulator with suction tube from the suction hose.

(3) Remove the O-RING from the suction tube and suction hose and discard it as non-reusable.

Caution: Seal the separated parts with vinyl tape to prevent foreign matter and water from entering.

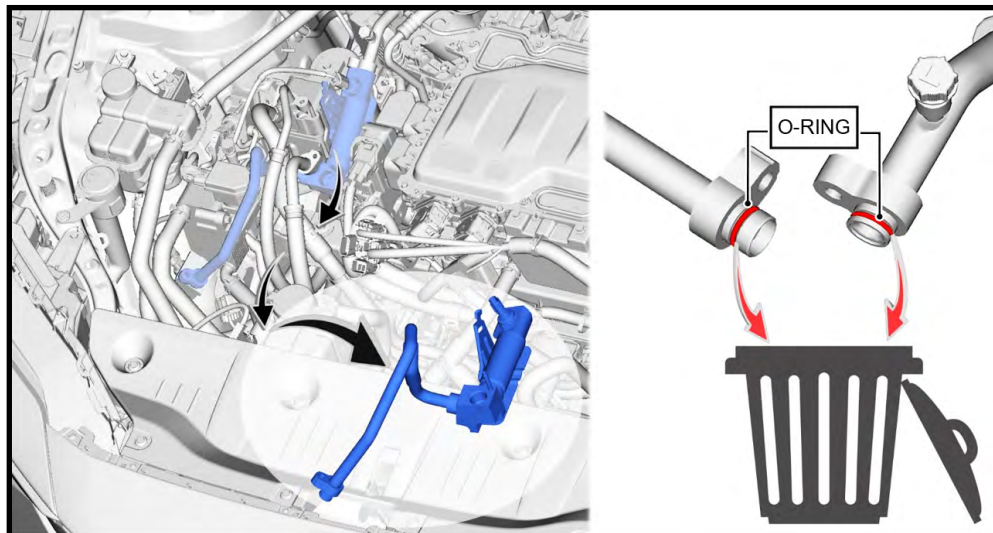

Continued...

STEP 11: REMOVE NO. 2 COOLER REFRIGERANT DISCHARGE HOSE

(1) Remove the connector and two bolts to disconnect the No. 2. Cooler refrigerant discharge hose and the No. 2. Air conditioning tube and accessory assembly.

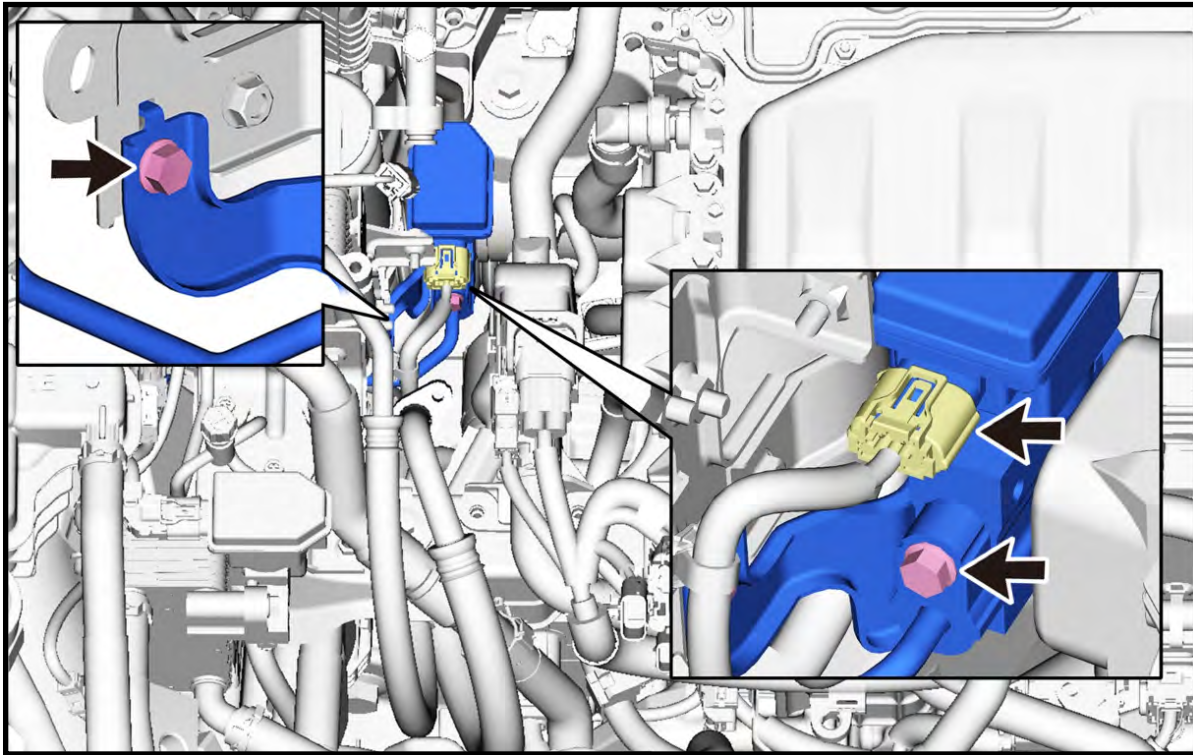

(2) Remove the bracket hook and move the No. 2 Cooler refrigerant discharge hose.

(3) Remove the O-ring from the No. 2 air conditioning tube and accessory assembly and discard it as non-reusable.

Caution: Seal the separated parts with vinyl tape to prevent foreign matter and water from entering.

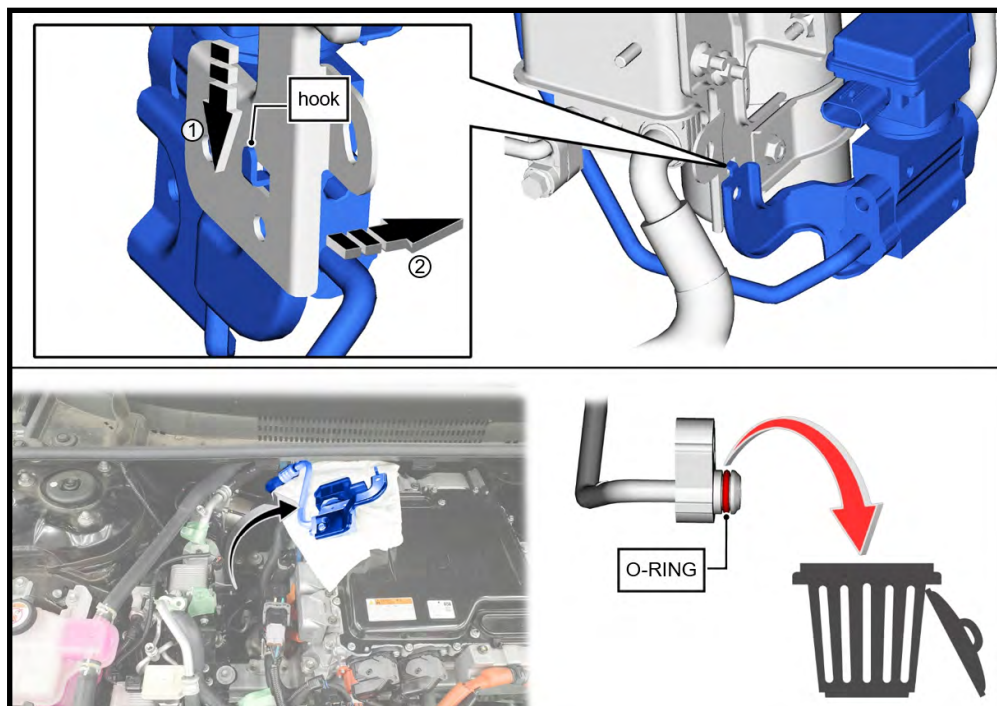

Continued...

STEP 12: SEPARATE CONDENSER ASSEMBLY WITH HEAT EXCHANGER UNIT SUB-ASSEMBLY

(1) Disconnect the three connectors and remove the two clamps securing the harness.

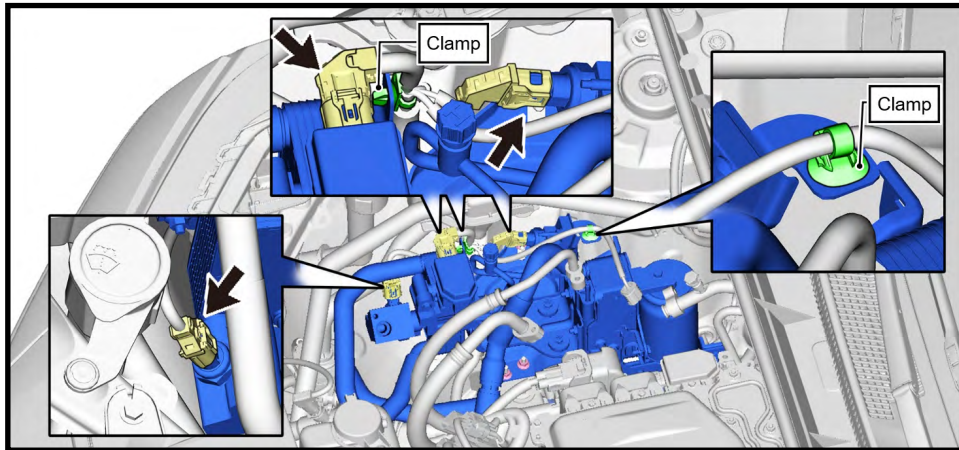

(2) Remove the three nuts and separate the condenser assembly with heat exchanger unit sub-assembly from the vehicle body.

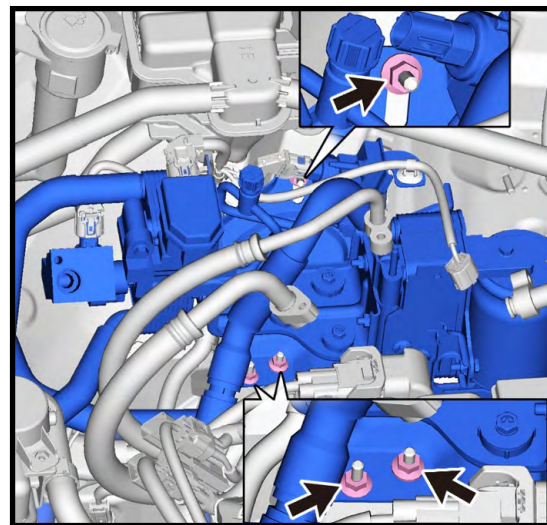

(3) To allow enough working space to remove and install the compressor, move the condenser assembly with heat exchanger unit sub-assembly to the front of the vehicle and secure the stays and body with cable tie or similar.

CAUTION: Do NOT disconnect coolant hoses. The coolant does not need to be drained to perform procedure

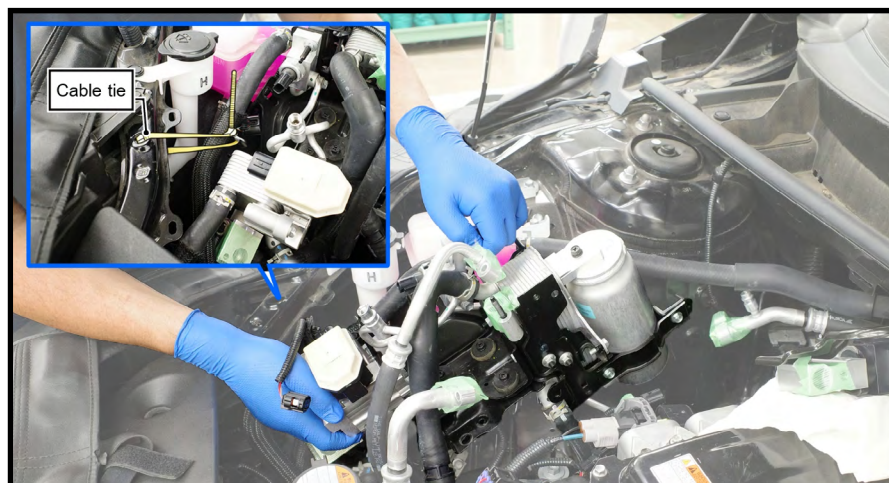

Continued...

STEP 13: REMOVE NO. 1 COOLER REFRIGERANT DISCHARGE HOSE

- (1) Disconnect the connector, release the clamp, and remove harness from the stay.
- (2) Remove one bolt the No. 1 cooler refrigerant discharge hose.

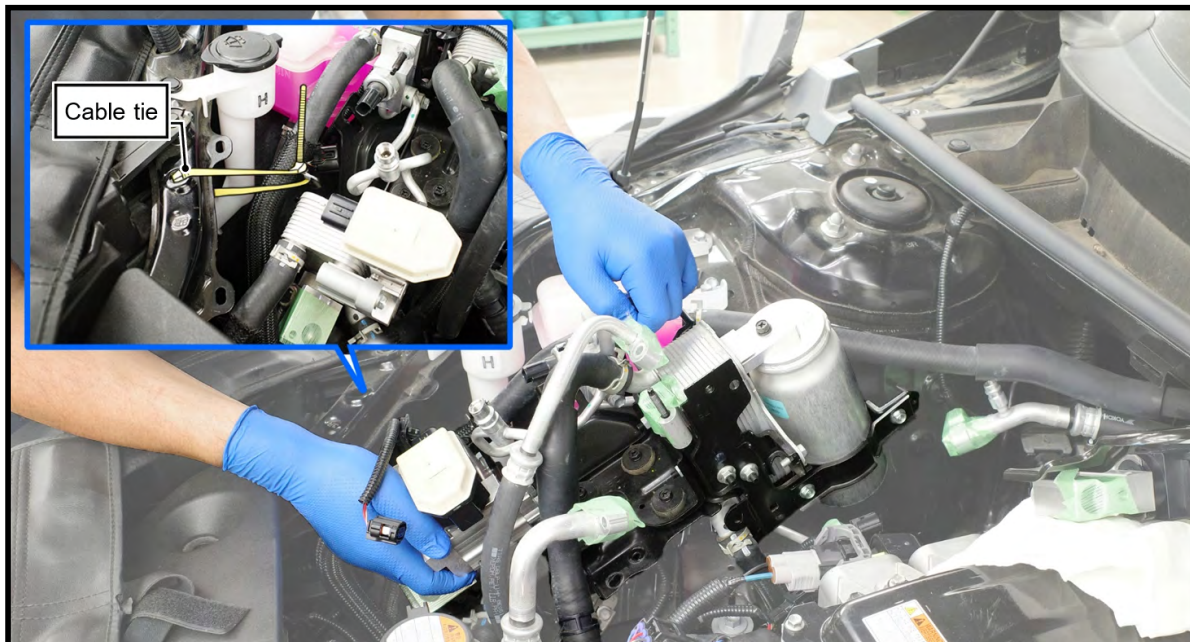

- (3) Remove the No. 1 cooler refrigerant discharge hose from the compressor.
- (4) Remove the O-RING from the No. 1 cooler refrigerant discharge hose and discard it as non-reusable.

Caution: Seal the separated parts with vinyl tape to prevent foreign matter and water from entering.

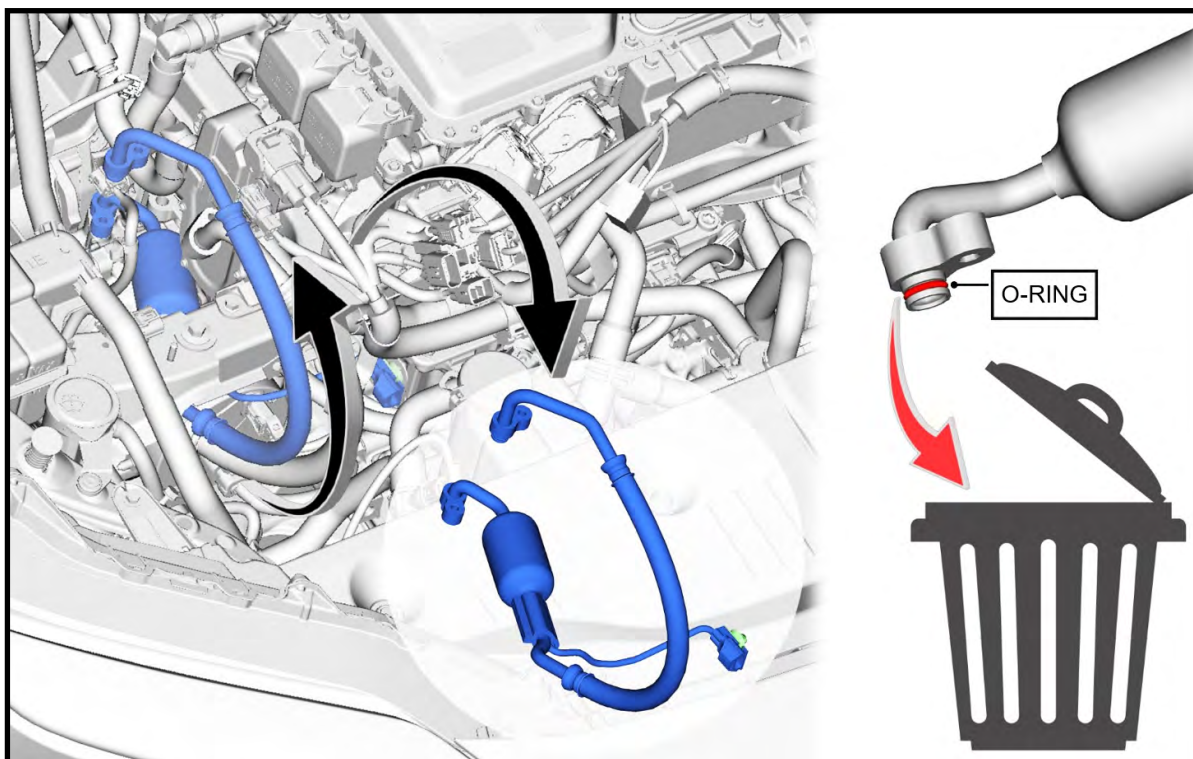

Continued...

STEP 14: REMOVE SUCTION HOSE SUB-ASSEMBLY

(1) Remove one bolt the suction hose sub-assembly.

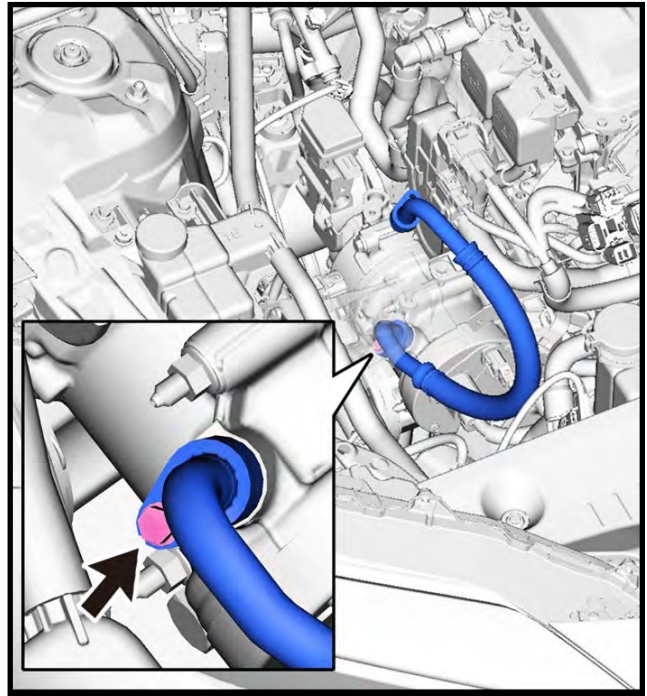

(2) Remove the suction hose sub-assembly from compressor.

(3) Remove the O-RING from the suction hose sub-assembly and discard it as non-reusable.

Caution: Seal the separated parts with vinyl tape to prevent foreign matter and water from entering.

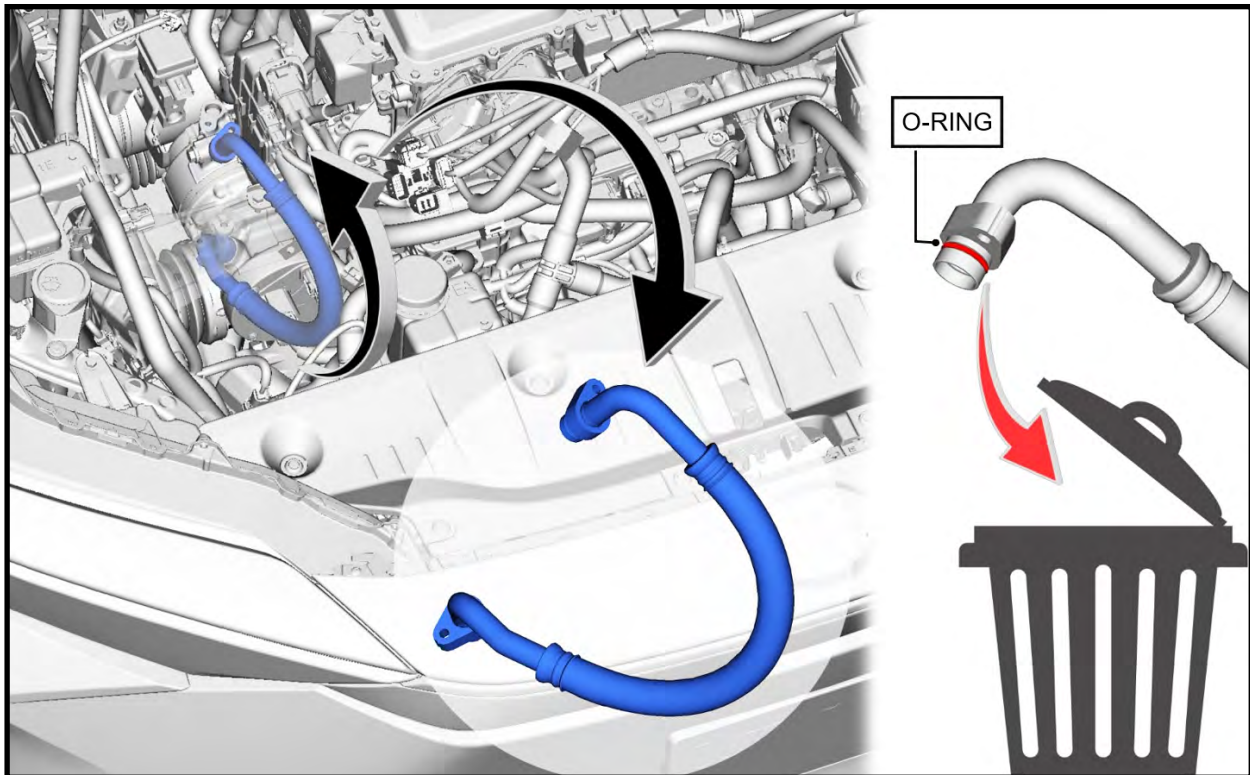

Continued...

STEP 15: REMOVE RECEIVER TANK

- (1) Remove the two bolts and receiver tank.
- (2) Remove one bolt, remove the band, and discard the receiver tank.

Note: The band will be relocated to a new receiver tank.

- (3) Remove the two O-RINGS from the condenser sub-assembly and discard them as non-reusable.

Caution: Seal the separated parts with vinyl tape to prevent foreign matter and water from entering

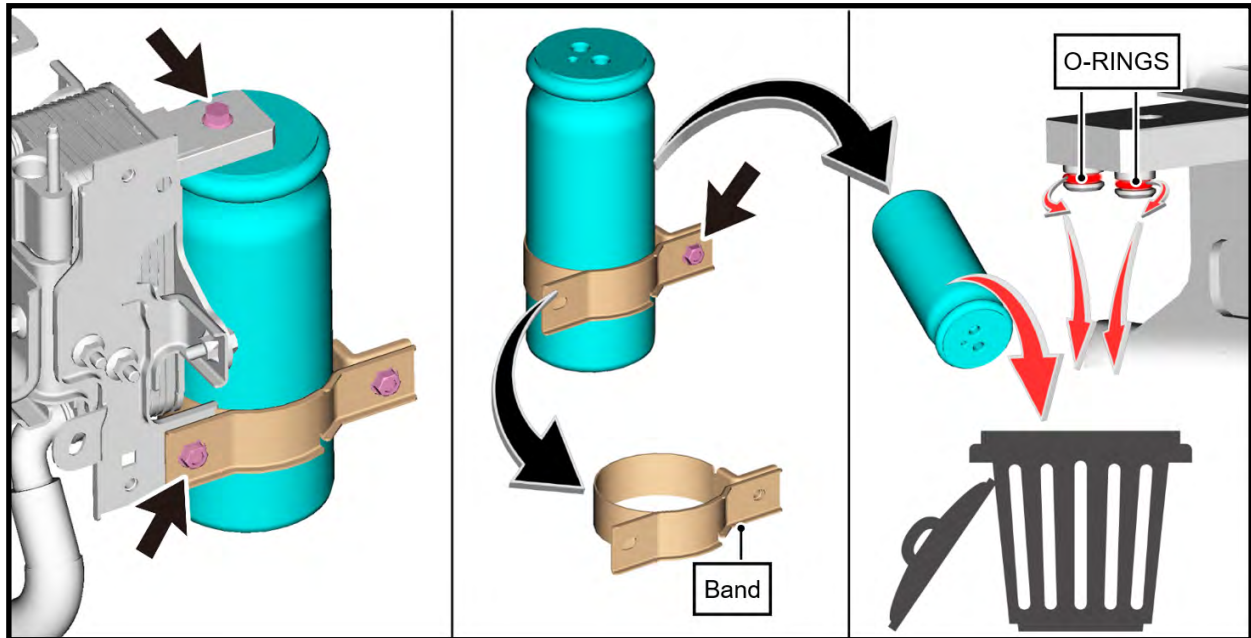

STEP 16: REMOVE COMPRESSOR WITH MOTOR ASSEMBLY

- (1) Disconnect the connector (A).
- (2) Wear insulating gloves, slide the green lock shown in the illustration to unlock it, and then remove the connector (B).

Caution: Insulate connector (B) with insulating tape.

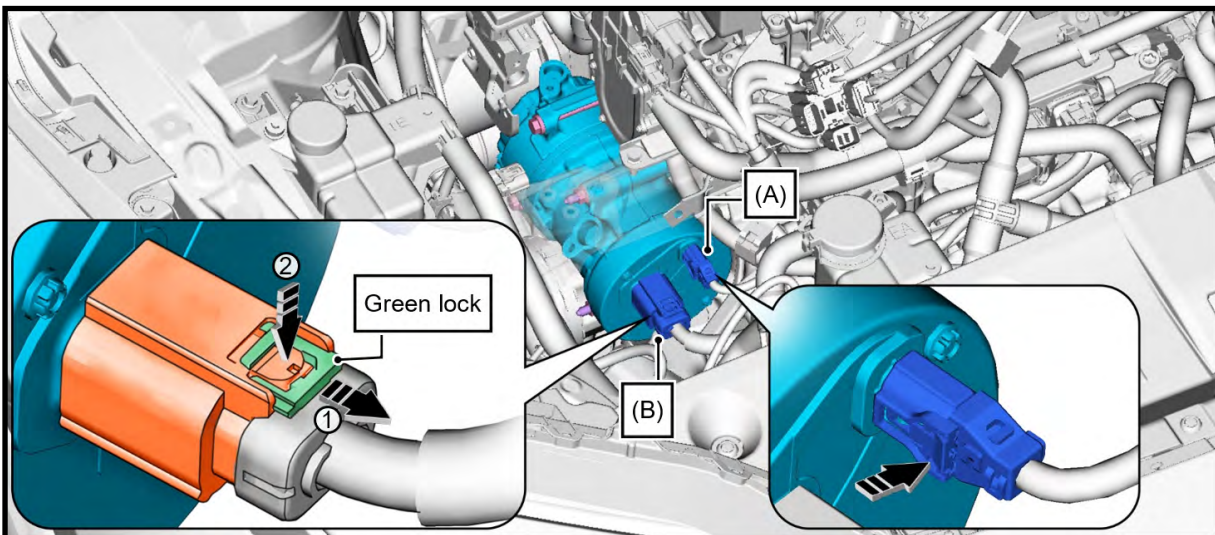

Continued...

(3) Remove the 2 bolts and 2 nuts.

(4) Remove the two stud bolts using an E8 “TORX” socket wrench.

Note: Loosen the bolts while supporting the compressor with motor assembly from below.

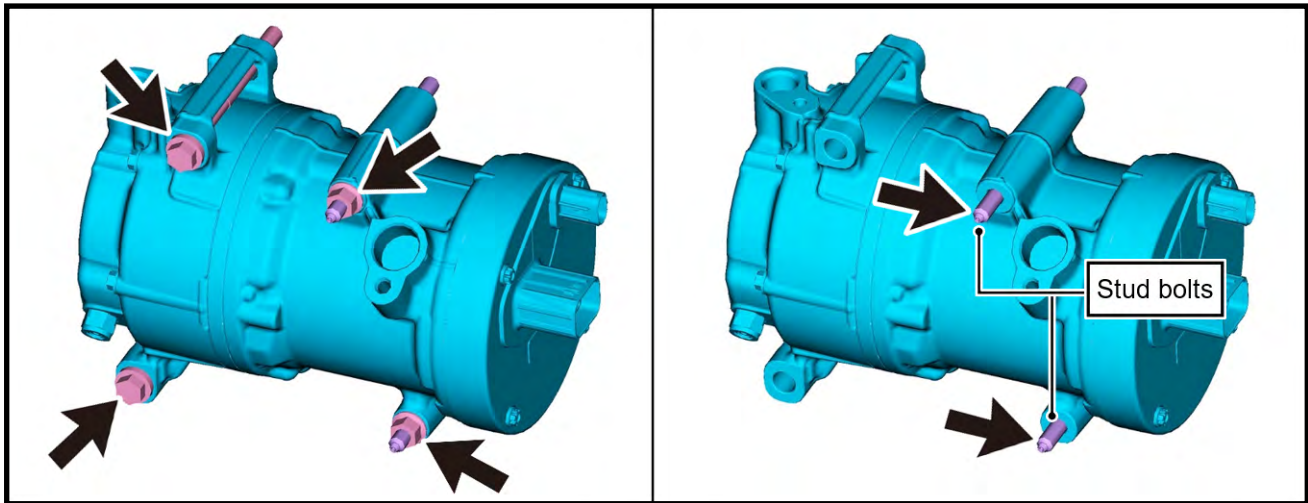

(5) Remove the compressor with motor assembly from the vehicle in the order shown.

Caution: The compressor with motor assembly is heavy, so be careful not to drop it and work so that it does not interfere with surrounding parts.

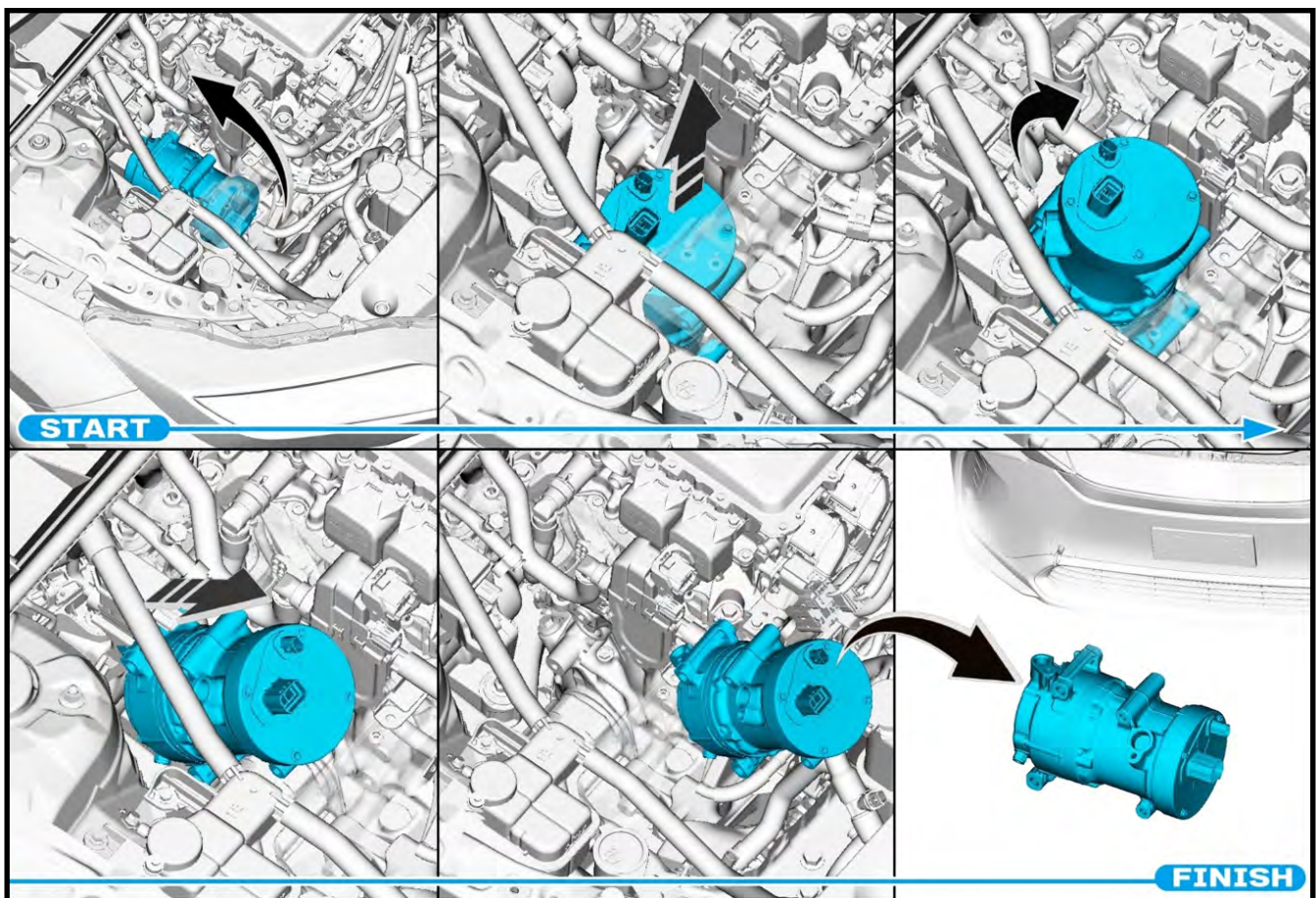

Continued...

STEP 17: ADJUST COMPRESSOR OIL

- (1) Remove the service valve from the new compressor to release the internal pressure.
- (2) Drain the oil from the old compressor and adjust the oil level in the new compressor to the standard according to the amount drained.

Standard:

•How to calculate the amount of oil to remove from the new compressor

Oil capacity inside the new compressor (120 ml) - Remaining oil amount in the removed compressor (OOml) - 65 ml

•This can be easily determined by calculating whether there is more or less than 55ml of oil left in the old compressor.

- If there is less than 55ml, you will need to drain the oil from the new compressor.

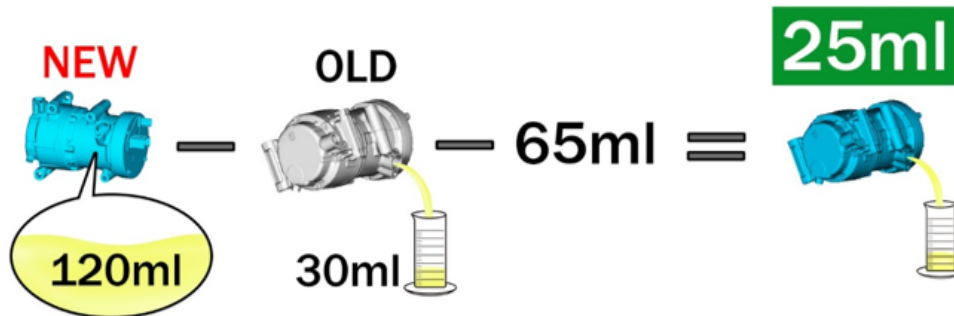

- If there is more than 55ml, there is no need to drain the oil from the new compressor.

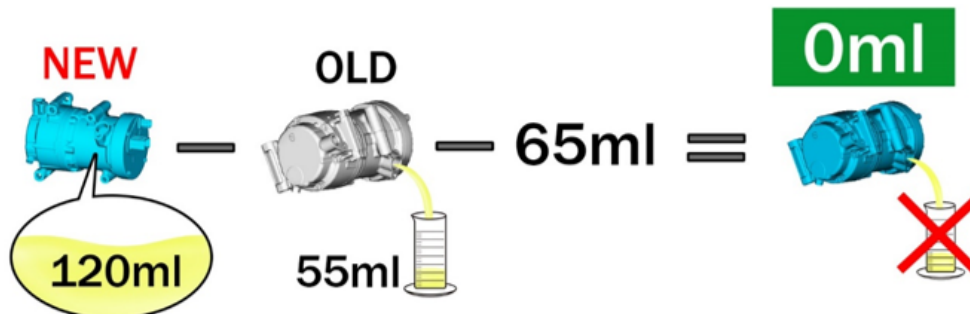

Caution:

- If a new compressor with motor assembly is installed without removing some oil, there will be too much oil in the system due to the oil remaining in the pipes of the vehicle. Excessive oil in the system prevents heat exchange in the refrigeration cycle and causes ineffective cooling.
- Be sure to use ND-OIL 11 or equivalent compressor oil. If any compressor oil other than ND-OIL 11 is used, compressor with motor assembly insulation performance may decrease, resulting in leakage of electric power.
- Be sure to drain the compressor oil from the intake port and refill it from the intake port.

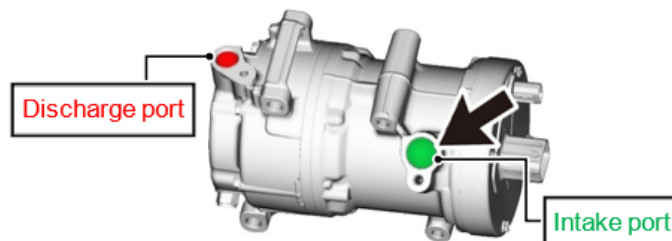

Continued...

Step 18: INSTALL COMPRESSOR WITH MOTOR ASSEMBLY

(1) Install THE NEW COMPRESSOR to the vehicle by reversing the removal procedure.

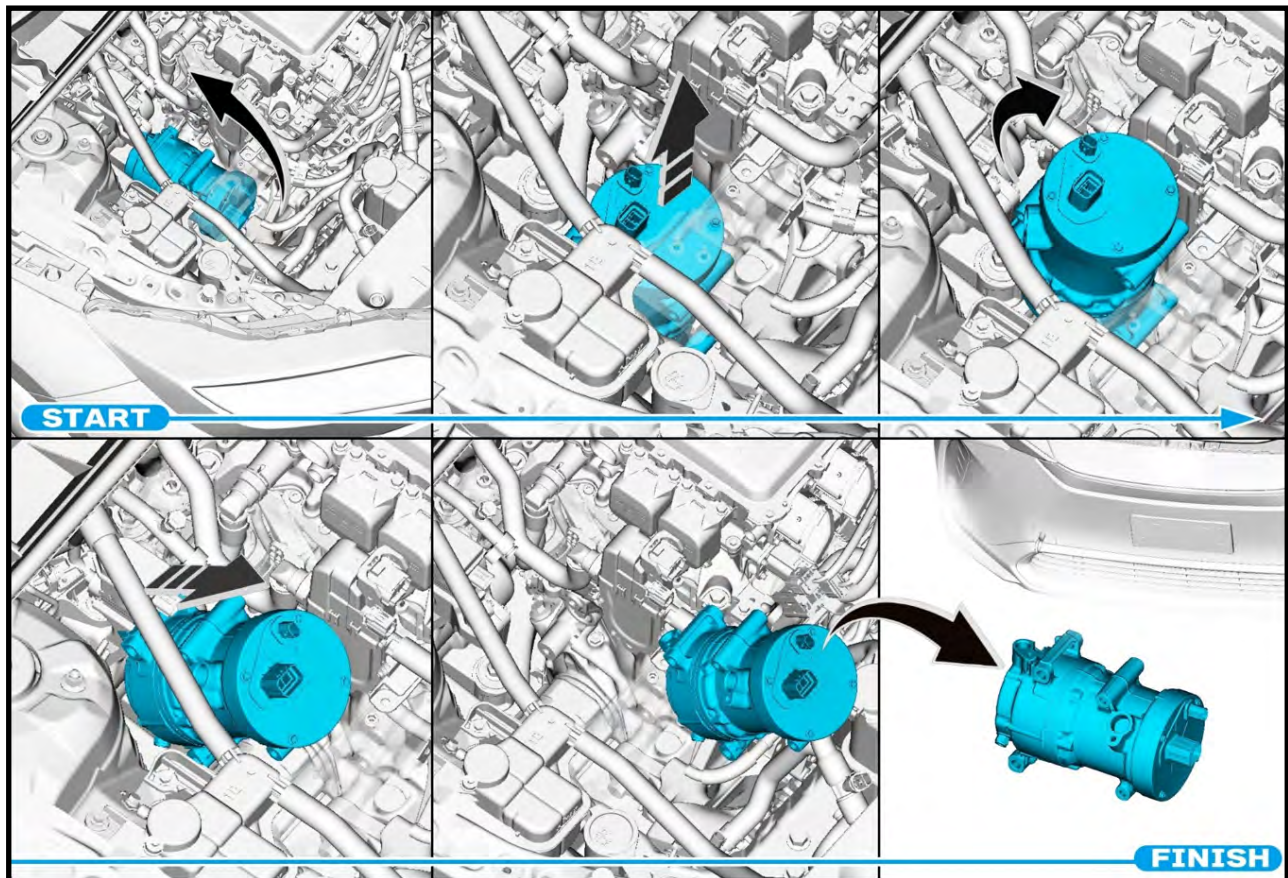

(2) Temporarily secure the compressor using two stud bolts. **Tighten stud to 9.8 N·m**

Note: Temporarily fastening a nut to the end of the stud bolt will prevent the stud bolt from falling off and make work easier. (Remove the nut temporarily when tightening the torque.)

Install the bolts and nuts and tighten them in the order shown to secure the compressor in place.

(3) Install the bolts and nuts and tighten them in the order shown to secure the compressor in place. **Tighten bolts and nuts to 24.5 N·m**

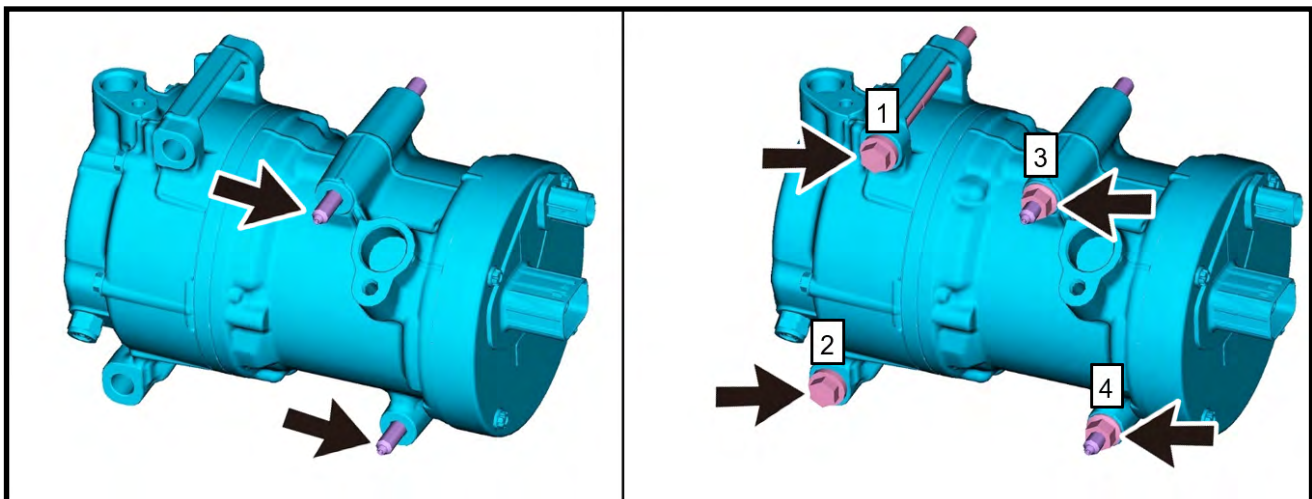

Continued...

- (4) Wearing insulated gloves, connect the connector (B) and slide the green lock to lock it securely.
- (5) Connect the connector (A).

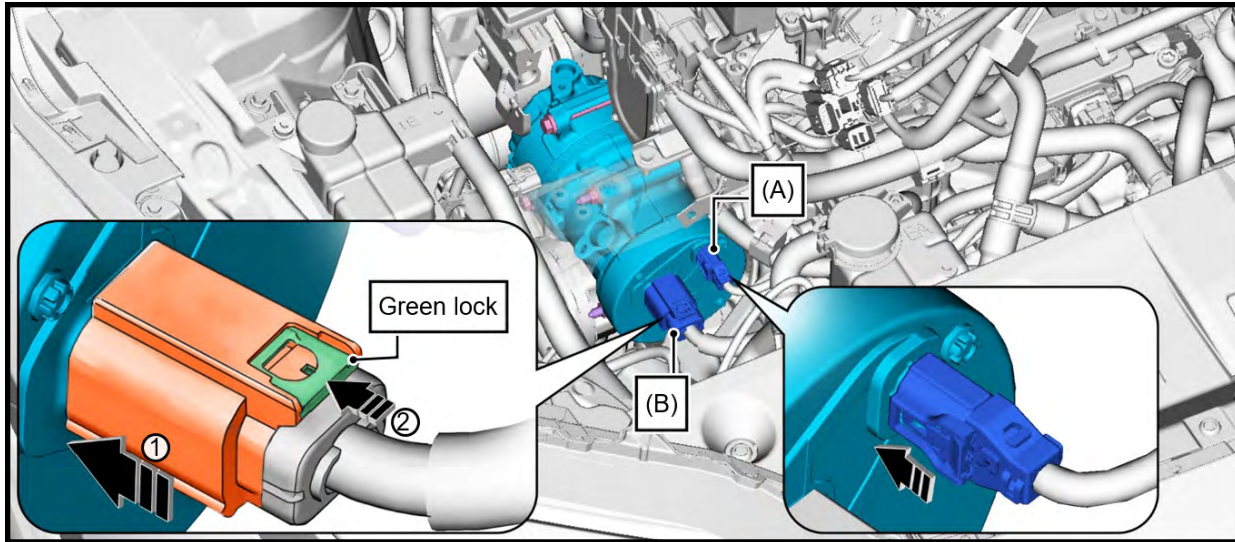

Step 19: INSTALL RECEIVER TANK

- (1) Attach the band to the new receiver tank and temporarily tighten it with one bolt.

Caution: If the band is fully secured to the receiver tank, the receiver tank will not be properly attached to the condenser sub-assembly, so proceed to the next step with the band loosely secured so that you can adjust its position.

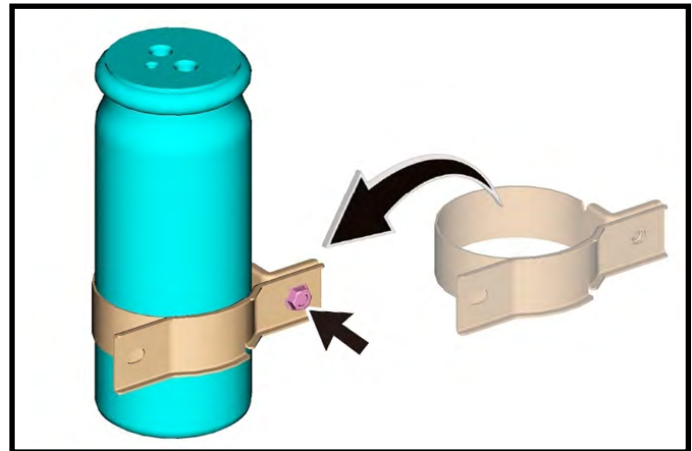

- (2) Install the NEW O-RINGS with compressor oil ND-OIL 11 or equivalent applied on the condenser sub-assembly.

- (3) Align the holes on the top of the receiver tank, attach it to the condenser sub-assembly, and secure it with one bolt and **torque bolt to 4.5 N·m**

O-RING Part Number: 9009914119 x2

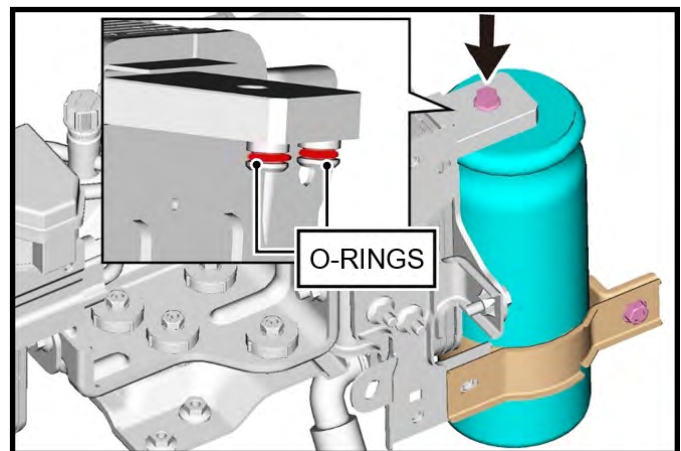

Continued...

(4) Adjust the position of the band, attach the bolt and tighten it in two places and **torque to 9.8N**.

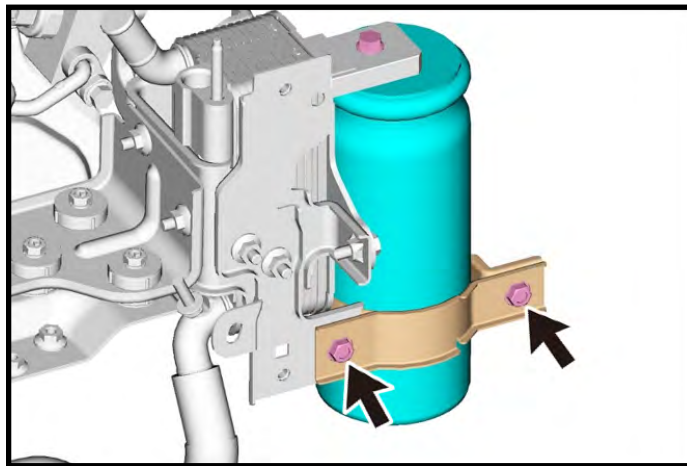

Caution:

- Do not use power tools or air tools to install air conditioning piping.
- Be sure to replace each O-ring with a new one.
- When installing a NEW O-RING, apply ND-OIL 11 compressor oil or equivalent.
- **Be careful not to pinch the harness, and make sure to connect the clamp and connector securely.**

Step 20: CONNECT SUCTION HOSE SUB-ASSEMBLY

(1) Torque bolt to 9.8 N·m

O-RING Part Number: 9009914169

Step 21 CONNECT NO. 1 COOLER REFRIGERANT DISCHARGE HOSE

(1) Torque bolt to 9.8 N·m

O-RING Part Number: 9009914120

Step 22: INSTALL CONDENSER ASSEMBLY WITH HEAT EXCHANGER UNIT SUB-ASSEMBLY

(1) Torque nuts to 9.8 N·m

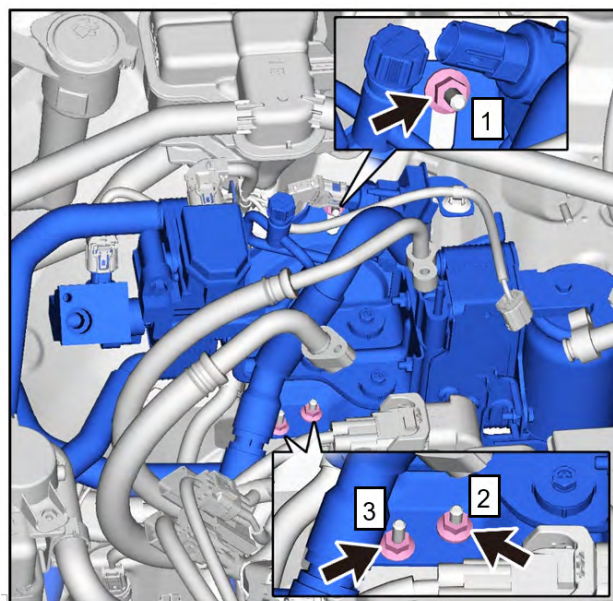

Continued...

STEP 23: INSTALL NO. 2 COOLER REFRIGERANT DISCHARGE HOSE

(1) Torque bolt to 9.8 N·m

O-RING Part Number: 9009914120

STEP 24: CONNECT PRESSURE REGULATOR WITH SUCTION TUBE

(1) Torque bolt to 9.8 N·m

O-RING Part Number: 9009914157 x2

STEP 25: INSTALL BATTERY COOLANT HEATER ASSEMBLY

(1) Torque bolt to 7.5 N·m

STEP 26: INSTALL WATER HOSE SUB-ASSEMBLY

STEP 27: INSTALL NO. 1 COOLER REFRIGERANT DISCHARGE HOSE

(1) Torque bolt to 9.8 N·m

O-RING Part Number: 9009914120

STEP 28: INSTALL SUCTION HOSE SUB-ASSEMBLY

(1) Torque bolt to 9.8 N·m

O-RING Part Number: 9009914169

STEP 29: INSTALL SERVICE PLUG GRIP

Caution:

- Wear insulated gloves while working.
- Before connecting the service plug grip, double-check that no parts or tools have been left behind, that the high-voltage terminals are tight, and that the connectors are properly connected.
- After tilting the service plug grip 90 degrees, slide it firmly until you hear a click.

STEP 30: INSTALL CONSOLE REAR END PANEL SUB-ASSEMBLY

STEP 31: CONNECT CABLE TO NEGATIVE AUXILIARY BATTERY TERMINAL

(1) Torque negative terminal to 5.4 N·m

STEP 32: CHARGE AIR CONDITIONING SYSTEM WITH REFRIGERANT

- (1) Perform vacuum purging using a vacuum pump or appropriate equipment.
- (2) Fill the air conditioning system refrigerant.

Continued...

STEP 33: WARM UP COMPRESSOR

(1) Keep the A/C switch on for at least 2 minutes to warm up the compressor.

STEP 34: INSPECT FOR REFRIGERANT LEAK

(1) After filling the refrigerant gas, use a gas leak detector to check for refrigerant gas leaks.

STEP 35: . INITIALIZATION AFTER RECONNECTING NEGATIVE AUXILIARY BATTERY TERMINAL

(1) Refer to Service Manual for instructions on General/SETUP/ WHEN DISCONNECTING OR RECONNECTING BATTERY TERMINAL/ AUTOMATIC LEARNING CHART

REPROGRAMMING FILE PROCEDURE

Reprogram the Air Conditioning Control Unit using the normal GTS+ reprogramming procedures and applicable file listed below. See TSB [14-30-24R](#) for further details regarding GTS+ reprogramming.

CAUTION: DO NOT perform any reprogramming prior to performing the inspection mode. The new software will cause inaccurate results.

MY	File Description	Target CID	New CID
23	NA(23MY)_8865F4216000.cuw	8865F4213100	8865F4216000
24-25	NA(24-25MY)_8865F4228100.cuw	8865F42220A0 or 8865F4228000	8865F4228100

NOTE: 2023MY vehicles MUST require the software outlined in EEA-23 to be installed prior to reprogramming. ALWAYS confirm the target CID prior to reprogramming.

CLAIM INFORMATION:

Solterra HVAC ECU Reprogramming ONLY			
Labor Description	Labor Operation #	Fail Code	Labor Time
A/C ECU Reprogramming Only	A180-555	WRD-25	0.7

Solterra HVAC ECU Programming & Compressor Inspection			
Labor Description	Labor Operation #	Fail Code	Labor Time
Reprogramming & DTC Check, and Compressor Check	A170-600	WRD-25	1.2
Reprogramming & DTC Check, Compressor & Receiver Replacement	A170-601	WRD-25	4.0
Reprogramming & DTC Check, Compressor Check, and Compressor & Receiver Replacement	A170-602	WRD-25	4.3

Continued...

IMPORTANT REMINDERS:

- SOA strongly discourages the printing and/or local storage of service information as previously released information and electronic publications may be updated at any time.
- Always check for any open recalls or campaigns anytime a vehicle is in for servicing.
- Always refer to STIS for the latest service information before performing any repairs.

SERVICE PROGRAM IDENTIFICATION LABEL:

Type or print the necessary information on a Campaign Identification Label. The completed label should be attached to the vehicle's left side radiator support bracket located behind the driver side headlamp. Additional labels are available through normal parts ordering channels. The part number is **MSA6P1302**, which comes as one sheet of 20 labels.

Part Number	Applicability	Description	Order Quantity
MSA6P1302	All Models	Campaign Completion Labels (contains one sheet of 20 labels)	1

SUBARU
Campaign Code
WRD-25
COMPLETED
DIST./DEALER NO.
SERIAL NO.
DO NOT REMOVE

PART RELEASE PROCESS

Currently, we have limited inventory of the recall compressor kit (part number 0400530242). In the rare situation where the compressor kit is required, a Non-Quality Report (NQR) must be submitted along with the parts order to get the part released. The following procedure must be followed in order to obtain one of these parts. Failure to adhere to these instructions will result in delays.

1. Place order for compressor kit: To expedite part release, enter "WRD25 -last 8 of VIN" in the PO field of the order (example: WRD25- SA100290).
2. Submit an NQR: The following documentation and testing steps must be added to the NQR:
 - When submitting a Non-Quality Report (NQR) you must select "To request release of a part to complete a recall or service campaign" as the Primary Objective.

Continued...

APPENDIX A

The following information is provided to help determine the presence of Foreign Material within the Air Conditioning system.

STEP 1: Discharge the Air Conditioning system

STEP 2: Remove the discharge hose from the A/C Compressor.

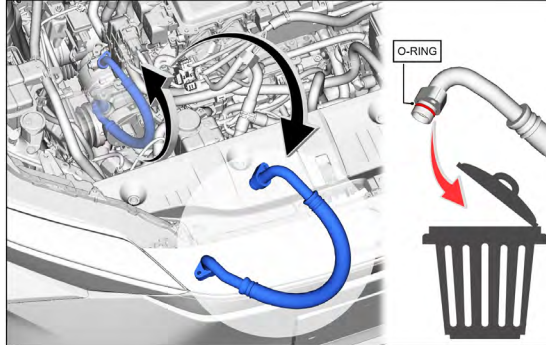

STEP 3: Inspect the compressor discharge port and the discharge hose for any signs of foreign material such as metal flakes or dust. If needed, a cotton swab can be used for further inspection. See the example images below.

NOTE: Blackened oil is not a sign of debris. Metal flakes/debris is a sign of failure.

Example images of foreign material found at the A/C compressor discharge port connection:



Example image of foreign material found at the A/C discharge hose connection:



Example images of foreign material **NOT** detected at the A/C compressor discharge port connections.



Example images of foreign material **NOT** detected at A/C discharge hose connection.

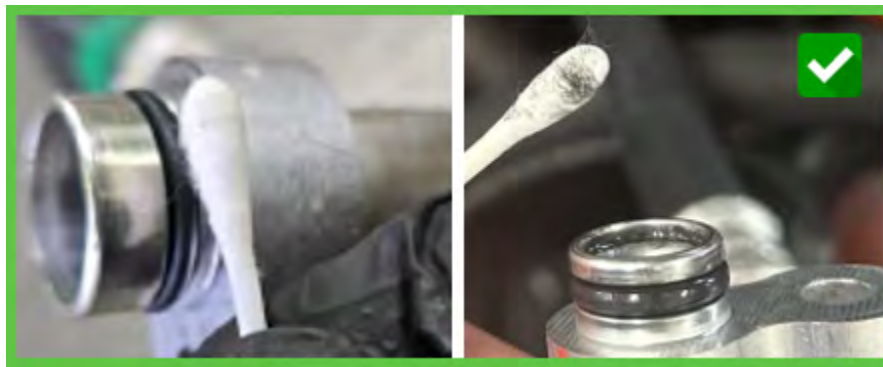

STEP 4: Compare the inspection results with the example images above. Has foreign material been detected?

YES: Replace the compressor and receiver dryer.

NO: Replace the compressor **ONLY**.

STEP 5: Proceed to the reprogramming procedure using the procedures outlined in 14-30-24R.

NOTE: The service procedure outlined in this appendix to not fall under the WRD-25R labor operations. Refer to the Labor Time Guide for claim information regarding appendix a service procedures.

Continued...

PART RELEASE PROCESS

Currently, we have limited inventory of the recall compressor kit (part number 0400530242). In the rare situation where the compressor kit is required, a Non-Quality Report (NQR) must be submitted along with the parts order to get the part released. The following procedure must be followed in order to obtain one of these parts. Failure to adhere to these instructions will result in delays.

1. Place order for compressor kit: To expedite part release, enter “WRD25 -last 8 of VIN” in the PO field of the order (example: WRD25- SA100290).
2. Submit an NQR: The following documentation and testing steps must be added to the NQR:
 - When submitting a Non-Quality Report (NQR) you must select “To request release of a part to complete a recall or service campaign” as the Primary Objective.

The image contains three screenshots of a software interface for creating a Non-Quality Report (NQR).
1. The first screenshot is titled "Create a QMR if you need to:" and includes a red note: "Note: QMR SHOULD NOT BE USED FOR WARRANTY PRE-AUTHORIZATION." It lists three bullet points: reporting a customer/repair concern, submitting files for a Technical Service Bulletin (TSB), and requesting a part on hold. A "Create QMR" button is at the bottom.
2. The second screenshot is titled "Create an NQR if you need to:" and lists two bullet points: submitting files for DSQM review to support warranty pre-authorization, and documenting a recall repair as directed by Subaru of America (SOA). A red box highlights the first bullet point. A note below states: "Note: A Non Quality Report is for reviewing diagnoses that require pre-authorization; it is not a repair approval. Claims pre-authorization is required for all final warranty approvals. See section 4.1 of Policy and Procedure manual for additional details." A "Create NQR" button is at the bottom.
3. The third screenshot is titled "Create an NQR" and shows a form. It has a "Retailer" dropdown menu, a "What is the primary objective of submitting this report?" dropdown menu, and two radio button options. The second option, "To request release of a part to complete a recall or service campaign", is selected and highlighted with a red box. The first option is "To submit files and documents for DSQM review to support warranty preauthorization before repair".

- Fail code WRD must be used.
- Concern, Cause, and Correction must include all details to support parts replacement. Please add the part order number into the Correction field. End result of the test must be documented in the Cause section.

Example:

- **Concern:** WRD-25
- **Cause:** There were no DTCs stored so the inspection mode was performed. Ambient temperature was under 77°F. The test plan was executed, and the refrigerant outlet temperature remained above 240°F for the full 10 minutes.
- **Correction:** Replace AC compressor and condenser as per the campaign. Order number 17912783

Data Requirements:

- GTS+ File with Health Check (RoBs are not required)
- Recorded Active Test as outlined in the Campaign notes:
 - AC control module: Record ALL PIDs during the active test plan for a minimum of 10 minutes.

WARNING: Files under 10 minutes or submissions of screenshots will be automatically rejected.

3. Monitor status of NQR: Following the submission of a Non-Quality Report (NQR), the District Service Quality Manager (DSQM) will be notified and will conduct a review to ensure accuracy and compliance.

Continued...

Retailers may monitor the status of their NQR by navigating to the Quality Assurance tab on the left-hand side of the screen, selecting Non-Quality Reports, locating the applicable report, and referencing the DSQM Status column.

The screenshot shows the TechShare application interface. On the left, a navigation menu is visible with 'Non Quality Reports' highlighted. The main content area is titled 'Non-Quality Reports' and includes a search bar and a 'Start New Report' button. Below this is a table with columns for 'Updated', 'Report ID', 'VIN', 'DSQM Status', and 'Role Review'. A specific report row is shown with a 'PENDING REVIEW' status in the DSQM Status column, which is circled in red. A red arrow points from the 'Non Quality Reports' menu item to this status.

The DSQM Status may display one of the following:

- **Pending Review:** The report has been submitted and is awaiting review by the DSQM.
- **Approved:** The report meets all established criteria, and the part replacement request has been approved. Parts Information Coordinators will reference this status to facilitate the release of parts. No additional action is needed.
- **More Information Needed:** The report does not contain sufficient information to reach a determination. The DSQM will provide comments outlining the additional details required and the appropriate next steps.

Continued...

IMPORTANT SAFETY RECALL

This notice applies to the VIN identified in the address section printed below



SUBARU

Subaru of America, Inc
PO Box 9103
Camden, NJ 08101-9877
844-373-6614
www.subaru.com

**Subaru Safety Recall WRD-25
NHTSA Recall ID 25V577
October 2025**

Dear Subaru Owner:

This notice is sent to you in accordance with the National Traffic and Motor Vehicle Safety Act.

Subaru of America, Inc. (Subaru) has decided that a defect which relates to motor vehicle safety exists in certain 2023-2025 model year Solterra vehicles.

You received this notice because our records indicate that you currently own one of these vehicles.

DESCRIPTION OF THE DEFECT AND SAFETY RISK

Due to a software issue in an electrical control unit in your vehicle, the windshield defroster may not work properly under certain conditions. This could reduce driver visibility and increase the risk of a crash.

WHAT SUBARU WILL DO

Subaru will update the programming of the involved electrical control unit, at no cost to you. Also, for customer satisfaction, retailers will inspect and, if necessary, replace the electrical HVAC compressor, free of charge.

WHAT YOU SHOULD DO

Please contact your Subaru retailer (dealer) immediately to schedule an appointment to have this safety recall completed at no cost to you.

HOW LONG WILL THE REPAIR TAKE?

The electrical control unit software update will take less than 45 minutes. If the electrical HVAC compressor needs to be replaced, the replacement process can take up to 4.5 hours. However, it may be necessary to leave your vehicle for a longer period of time to allow your Subaru retailer flexibility in scheduling.

OWNER INFORMATION

Government regulations require that recall notifications be sent to the last known owner of record. That information is based primarily on state registration and title data. If you are a lessor of this vehicle, federal regulations require you to forward this notice to your lessee within ten days.

If you have moved or sold your vehicle, please go to <https://www.subaru.com/support/customer-support.html> to send us your updated information.

IF YOU HAVE PREVIOUSLY PAID FOR A REPAIR

If you have already paid for repairs associated with this condition, you may be eligible for reimbursement. Reimbursement consideration will be based on the amount an authorized Subaru retailer in your area would charge for the same repair.

Please send the original service repair order, which has the name of the repair facility, date of repair, mileage at the time of repair, complete 17-digit vehicle identification number (VIN), and your name, with correct mailing address and telephone number to the address listed below:

Subaru of America, Inc.
Attention: WRD-25 Recall
2670 Executive Dr
Indianapolis, IN 46241

Please send original receipts only and retain a photocopy for your records. Please be assured that we will attempt to process your reimbursement request as quickly as possible, but it may take up to 60 days for this process to be completed.

IF YOU NEED FURTHER ASSISTANCE:

To locate the nearest Subaru retailer, you can access our website at www.subaru.com and select 'Find a Retailer.'

For additional information, please go to: <http://www.wrd25.service-campaign.com>.

If you need additional assistance, please contact us directly:

- By e-mail: Go to <https://www.subaru.com/support/customer-support.html> and select 'Email Us'
- By telephone: 1-844-373-6614
Monday through Friday between 8:00 a.m. and 7:00 p.m. ET
- By U.S. Postal mail:
Subaru of America, Inc.
Attn: Customer Advocacy Department
P.O. Box 9103, Camden, NJ 08101-9877

To subscribe to the NHTSA Recall Notification email System, please go to: <https://www-odi.nhtsa.dot.gov/nhtsa/subscriptions>.

Please contact us immediately if the Subaru retailer fails or is unable to make the necessary repairs free of charge.

If your dealer fails or is unable to remedy this defect without charge, or within a reasonable amount of time, you may submit a written complaint to: Administrator, National Highway Traffic Safety Administration (NHTSA), 1200 New Jersey Ave., SE, Washington, DC 20590 or call the toll-free Vehicle Safety Hotline at 1-888-327-4236 (TTY: 1-800-424-9153) or go to <http://www.NHTSA.gov>.

Your continued satisfaction with your Subaru is important to us. Please understand that we have taken this action in the interest of your safety and your vehicle's proper operation. We sincerely apologize for any inconvenience this matter may cause and urge you to schedule an appointment as soon as possible.

Sincerely,

Subaru of America, Inc.

A subsidiary of SUBARU CORPORATION