

1810/02 ABS Longitudinal Acceleration Fault

COMMUNICATION:

FIELD SOLUTION: TSB 54-107 WST, TSB 54-379 FTL

PUBLISH DATE: 11/25/2025

TOPIC BACKGROUND:

PRIMARY EFFECT:

- The 1810/02 ABS DTC will set when there is a discrepancy in the longitudinal acceleration from the wheel speed sensors and the ESC sensor. When there is a difference, the system will disregard the ESC sensor and as a result ESC is turned off, and the driver will get a dash warning light letting them know the system is not working.

AFFECTED MODELS:

- WST 49X, 47X, FTL New Cascadia, M2+, 108SD+, 114SD+, 114SD, 108SD

VISUALIZATION:

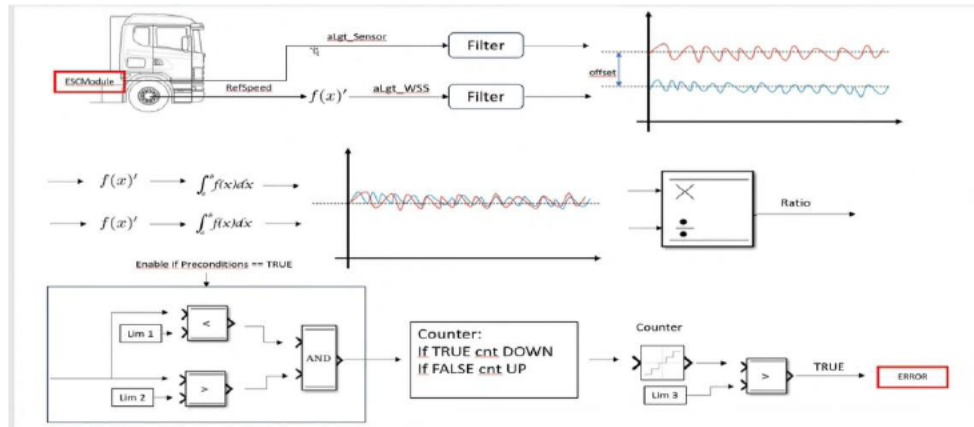

PROGRESS UPDATES:

- Updated ECU's from WABCO are being stocked into the PDC's, and the production changeover for the new updated GVC software is January 1st, 2026.

TOPIC RESOLUTION INFORMATION:

PRODUCTION CHANGEOVER WEEK/MONTH:

- Production Changeover: 1/1/26 for updated GVC software

RESOLUTION:

- Short-Term Field Containment: Replace with new ECU with correct part number in TSB
 - 2/23/26