



STAR ONLINE PUBLICATION



Case Number: S2623000019

Release Date: March 2026

Symptom/Vehicle Issue: Water Leak From Roof Area.

Models Affected: 2020-2026 Ram Promaster (VF)

Discussion: See the below for water leak testing the roof seals.

1. Remove headliner if necessary to gain access to the roof. Refer to Service Library 23 - Body / Interior / HEADLINER / Removal.
2. Using a helper, perform a water leak test of the roof. Use regulated shop air turned down to 10-15 psi of pressure with a rubber tip safety nozzle and necessary personal protection equipment (PPE) such as gloves, face shield and safety glasses, long sleeved shirt and pants. Direct the air to the interior side of the roof ditch area and roof rack mounting locations. Apply a leak detection fluid such as kids bubbles or MOPAR foaming glass cleaner to the suspect seams. A leak will be highlighted by bubbles forming on the roof exterior.
3. Use a grease pencil to mark leak areas. Continue testing the roof seals in case there are multiple places where a leak is present.
4. Once leak testing is complete, wash and dry the roof.
5. Using Kent Products Hi-Tech Clear seam sealer P10200 or equivalent, seal the voids or leak paths found during the water leak test. Follow the product application and curing instructions.

This document does not authorize warranty repairs. This communication documents a record of past experiences. STAR Online does not provide any conclusions about what is wrong with the vehicle. Rather, it captures all previous case details that appear to be similar or related to the vehicle symptom / condition. You are the expert, and you are responsible for deciding on the appropriate course of action.

Contact STAR Center, or your Technical Assistance Center Via TechConnect, eCONTACT or Service Library entry if no solution is found.



STAR ONLINE PUBLICATION



6. Remove grease pencil marks using isopropyl alcohol (rubbing alcohol) and a microfiber towel.

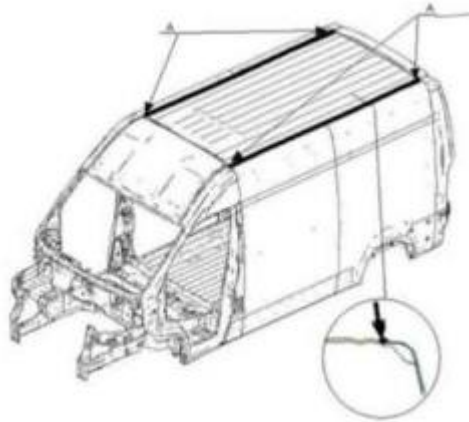

Roof Ditch And Rack Seam Sealer Location

7. Perform a post repair water leak test using shower head or open hose pressure (no power washes or automatic car washes) to arc the water on the roof. Flood the roof with water for 15 minutes. If there are no signs of water leaks, assemble the vehicle and return to the owner. If leak still occurs, perform a second bubble test starting at step 1.

This document does not authorize warranty repairs. This communication documents a record of past experiences. STAR Online does not provide any conclusions about what is wrong with the vehicle. Rather, it captures all previous case details that appear to be similar or related to the vehicle symptom / condition. You are the expert, and you are responsible for deciding on the appropriate course of action.

Contact STAR Center, or your Technical Assistance Center Via TechConnect, eCONTACT or Service Library entry if no solution is found.