



# INSTRUCTION TO SERVICE

<b>ITS: 61079</b>		<b>3/20/2026</b>
<b>SECTION:</b>	219 – Engine and Transmission	
<b>SUBJECT:</b>	Reverting Bypassed DEF Tank Sensors – 22 Inch Tank CA	
<b>ISSUE:</b>	DEF Tank Sensors Bypassed During Parts Shortage	
<b>SUMMARY:</b>	Remove Bypass Calibration from Engine ECM and New Sensor Installation AR	

# ITS 61079

**THIS ITS DOCUMENT SHOULD BE RETAINED AND REFERRED TO FOR FUTURE MAINTENANCE UNTIL THE NEW FLYER PARTS AND/OR SERVICE MANUAL IS UPDATED TO REFLECT WORK DONE AS A RESULT OF THIS DOCUMENT. ENSURE THAT THIS DOCUMENT IS AVAILABLE FOR PARTS AND MAINTENANCE STAFF GOING FORWARD.**



## NEW FLYER<sup>®</sup> PROCEDURE:

1. Set park brake and chock wheels.
2. Turn the main battery disconnect switch to the “OFF” position.
3. Read these work instructions in their entirety prior to beginning the work.
4. Inspect the DEF tank sensor for replacement.
  - a. If the sensor harness is cut, this indicates the original sensor from the bypass operation is installed. Proceed to part A.
  - b. If a new sensor has been installed in preparation for reverting the calibration, proceed to part b.

### Part A – Install New DEF Tank Sensor

5. Sourcing the new sensor
  - a. When the customer requested a bypass calibration, the process was to order a new sensor. This sensor is to be used to replace the failed sensor.
  - b. Through this ITS, the customer will be able to order a sensor if required.
    - 5.b.1. Contact your MCI/New Flyer field service representative if a sensor is needed.
6. Access the DEF tank per the vehicle maintenance manual.
7. Disconnect the coolant outlet, coolant inlet, DEF suction, and DEF return lines.  
See Figure 1 and Figure 2 below.

**NOTE: Ensure the coolant lines are blocked off prior to removing hose clamps. Otherwise coolant will leak out of the lines. Also note which coolant line is for the MFHU outlet, and which is for the MFHU inlet so that they are not reversed on reassembly.**

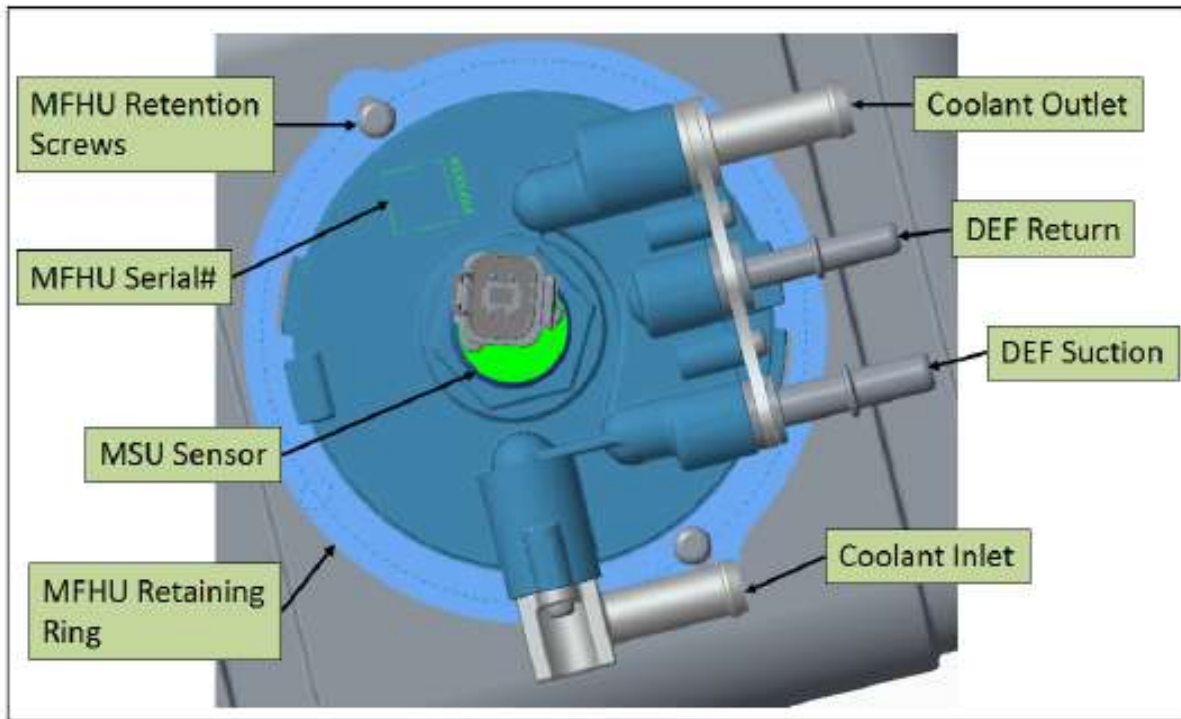

Figure 1: Top View of the Multi-Function Head Unit Assembly (MFHU).



Figure 2: DEF line removal.

8. Proceed to remove the DEF tank following the instructions provided in your New Flyer Service Manual.
9. Remove the two #10-32 screws securing the MFHU. See Figure 3 below.

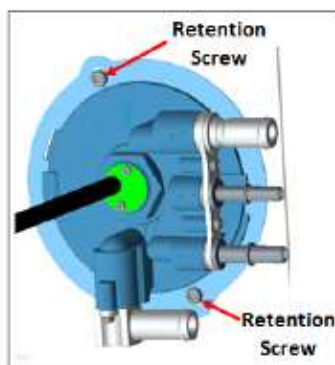
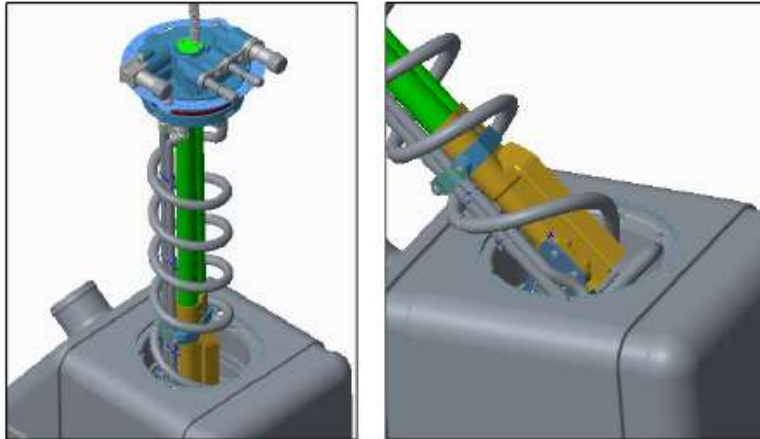

Figure 3: Remove and retain MFHU retention screws.



**NEW FLYER**

10. Pull the MFHU out of the DEF tank until the bottom of the header is at the bottom of the tank bore. At this point, the MFHU will have to be tilted so that the heel of the sensor faces upwards. See Figure 4 below.



**Figure 4: MFHU removal process.**

11. With the MFHU in hand, loosen and remove the Tri-Function Sensor nut using a wrench.

👉 **NOTE: Set the sensor nut and O-ring to the side.**

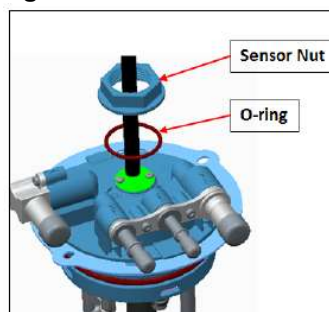
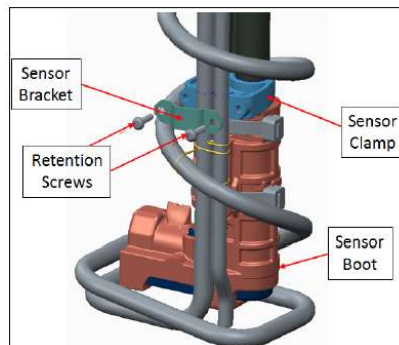

**Figure 5: Remove and retain sensor nut and O-ring.**



**NEW FLYER**

12. Then remove the retention screws and sensor bracket. Slide the Tri-Function Sensor from the MFHU mounting base, being careful to not damage the MFHU coil and suction tubes while removing the sensor. Refer to Figure 6.



**Figure 6: Remove and retain sensor bracket and retention screws.**

13. Ensure that the new GEN 7 sensor has an O-ring installed. See Figure 7 below.

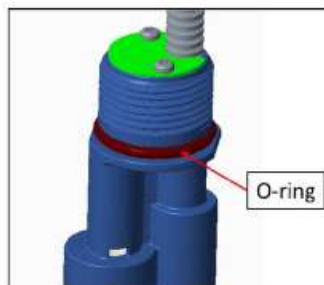

**Figure 7: Ensure that an O-ring is installed on the new Tri-Function Sensor.**

14. Feed the sensor harness through the bottom of the mounting base, as shown in Figure 8.

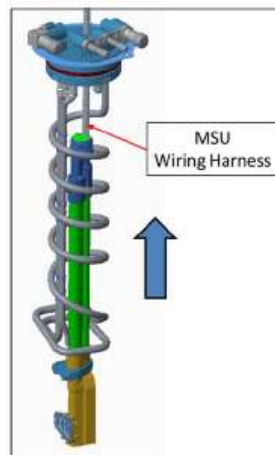

**Figure 8: Feed the sensor harness through the bottom of the mounting base.**



**NEW FLYER**

15. Press the Sensor clamp onto the MFHU tubes to align with the sensor bracket and the foot of the sensor. The sensor clamp must rest on the pad feature of the sensor housing. See Figure 9.

**Torque screws to 13 - 19 in-lbs.**

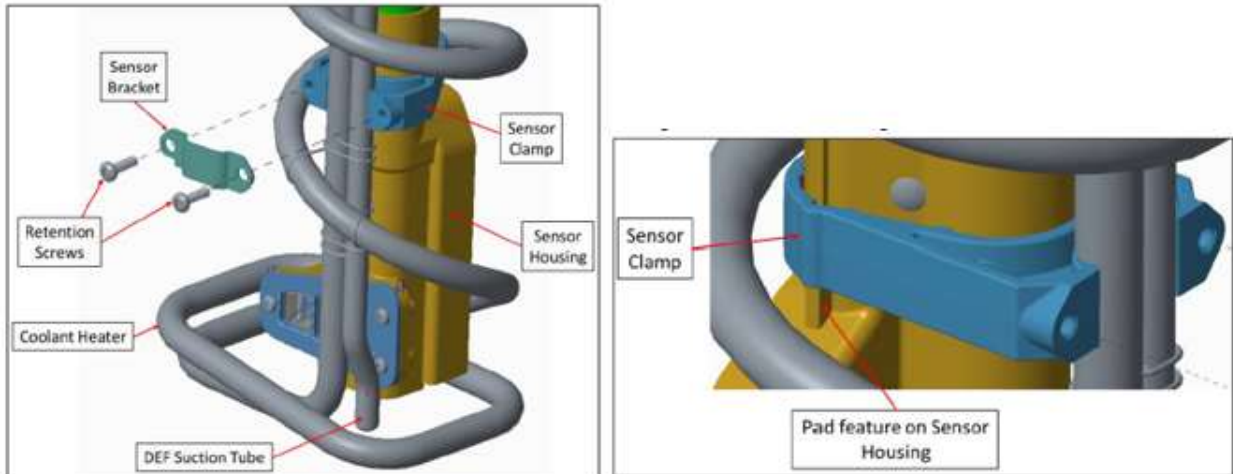

**Figure 9: Secure GEN 6 Tri-Function Sensor with the sensor bracket and retention screws.**

16. Position the top of the sensor through the mounting base such that the upper threaded portion of the sensor is through the base of the MFHU, as seen in Figure 10 below. Ensure the top surface of the header is clean.

**Tighten sensor nut to 40 - 44 in. lbs.**

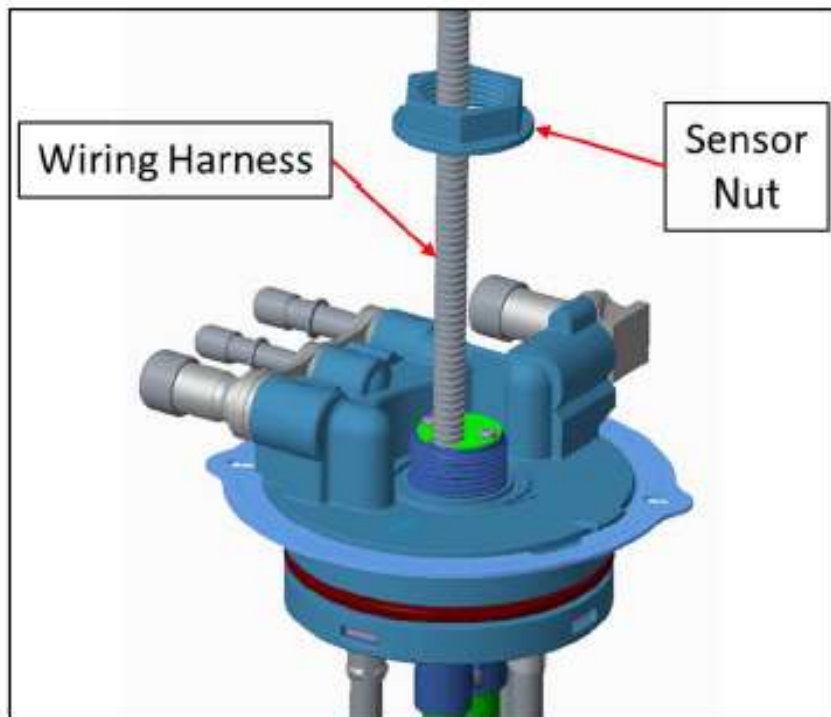

**Figure 10: Ensure that the top of the MFHU is clean and tighten the sensor nut.**



**NEW FLYER**

17. Now, apply a thin layer of O-ring lubricant to the MFHU O-ring, per Figure 11 below.

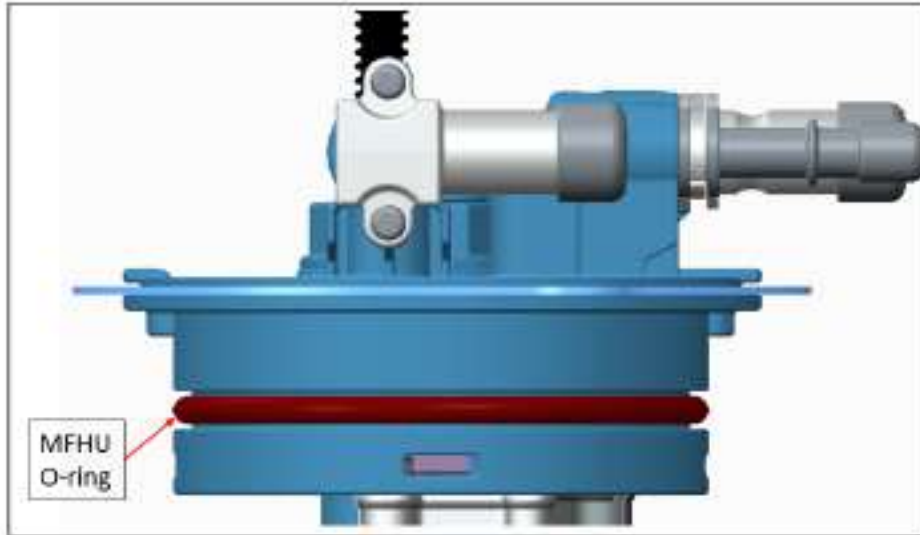

Figure 11: Apply lubricant onto the MFHU O-ring.

18. Tilt the MFHU assembly to an approximate 45-degree angle, with the heel of the Tri-Function Sensor angled upward, overtop of the DEF tank bore hole. Place the toe of the heater coil into the tank and angle the MFHU assembly upwards as it is lowered into the DEF tank. Refer to Figure 12 below.

**⚠ WARNING: DO NOT push the MFHU directly into the DEF tank as this could damage the unit.**

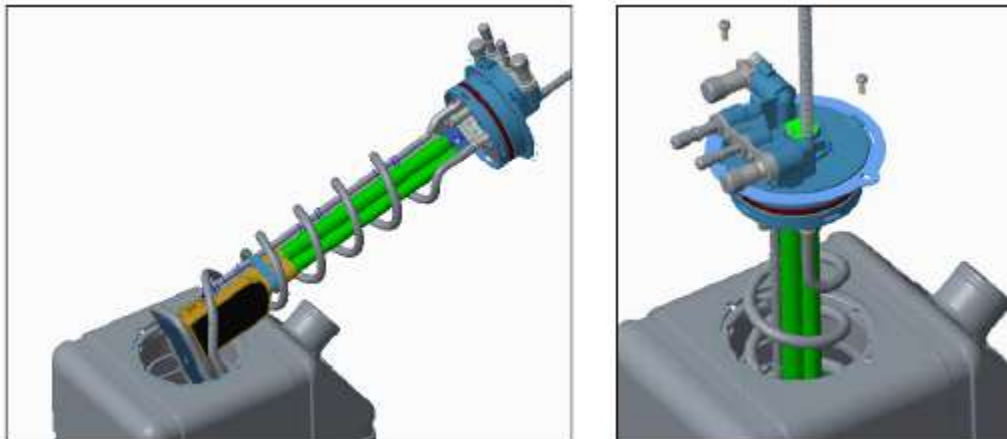

Figure 12: MFHU installation process.



**NEW FLYER.**

19. Press on the top of the MFHU mounting base until it is completely seated in the tank bore (do not press on the fittings). Refer to Figure 13 below

☞ **NOTE:** The lugs on the MFHU will align with the recesses on the tank bore when oriented correctly.

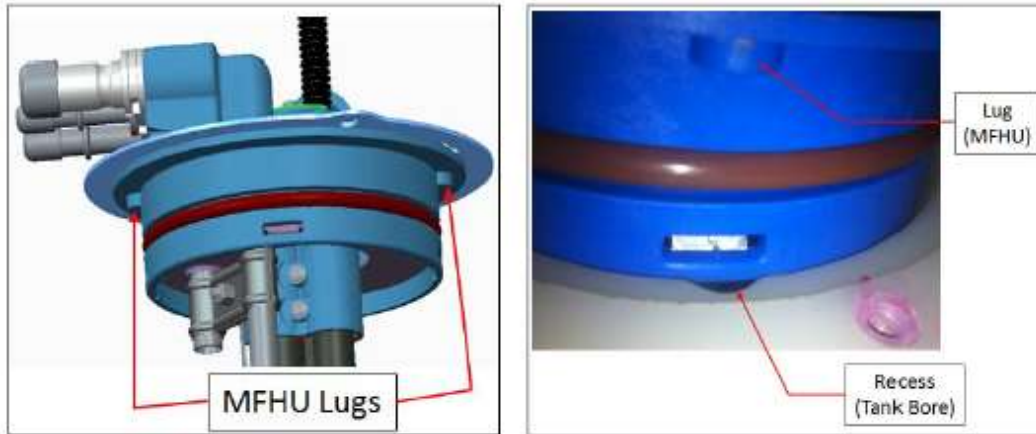

Figure 13: Align MFHU lugs with the recesses on the tank bore during re-assembly.

20. Position the retaining ring on the MFHU to align with the tank mounting holes and **tighten the retention screws to 20 - 30 in-lbs**. Refer to Figure 14 below.



Figure 14: Secure MFHU assembly to the DEF tank with the two retention screws removed in Step 2.

21. Proceed to install the DEF tank following the instructions provided in your vehicle Service Manual.

22. Re-install the DEF lines by pushing them back onto the fittings, until a click is heard. The DEF lines cannot be reversed as the fittings are sized differently. Re-install the coolant lines and tighten hose clamps until snug.

☞ **NOTE:** Ensure that the coolant lines are not reversed on reassembly.



**NEW FLYER®**



**Figure 15: MFHU line installation.**

23. Sensor installation complete.



**Part B – Install Original Engine ECM Calibration**

- 24. Turn on the main battery switch and engine run switch (ignition).
- 25. Using Cummins Insite Pro diagnostic software, connect to the engine and retrieve the current ECM calibration code installed. See figure 17.

**NOTE:** The ECM calibration code for your vehicle may be different then what is shown in the screenshots.

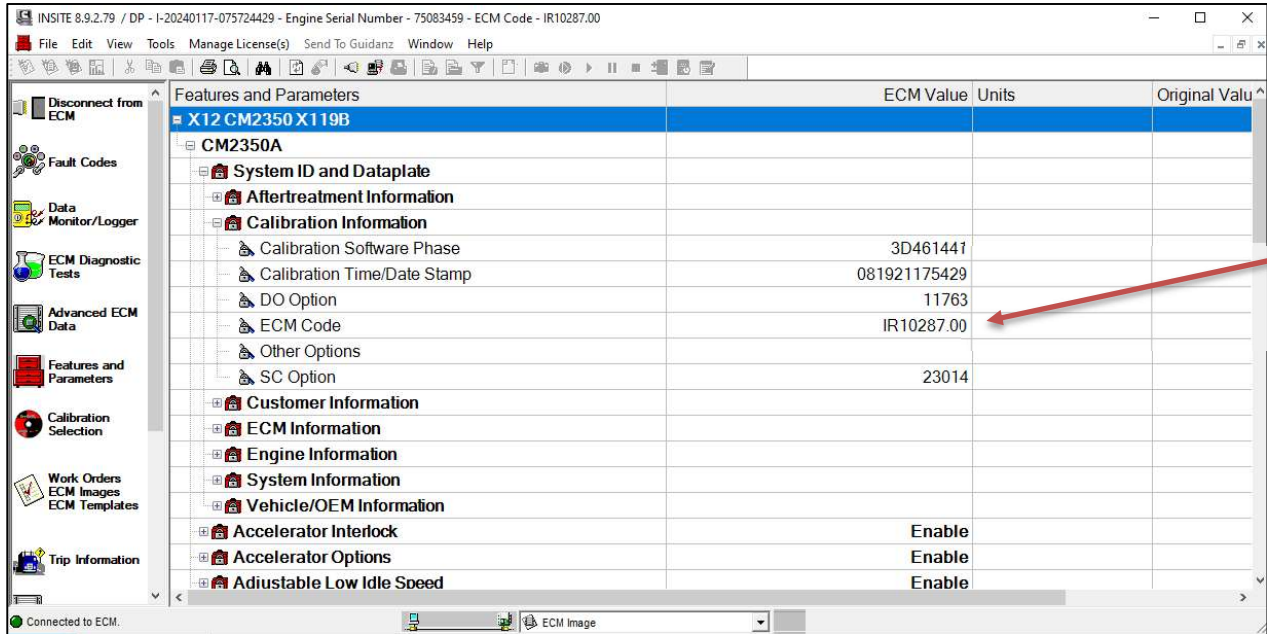

**Figure 17**

- 26. Disconnect Insite from the engine.
- 27. Using the ECM calibration look up tool (excel spreadsheet), enter in the current ECM code to retrieve the original production ECM code number. See figure 18. Alternatively, this can be retrieved on the ECM decal or on the Cummins Quickserve website.

	A	B	C
1			
2	<b>Bypassed Calibration</b>	<b>Production Calibration</b>	
3	IR10287	IR10129	
4			
5	<b>Input the current ECM code from the engine, and hit "Enter"</b> (Use TAB to jump to the Tan cell)	<b>Load this ECM code for reverting back to the production calibration</b>	
6	Example: AB12345		
7			
8			
9			
10			

**Figure 18**

28. Using Insite and on the Calibration Selection page, select ECM/PDD Code Search. See figure 19. Note- Insite is not connected to the engine at this time.

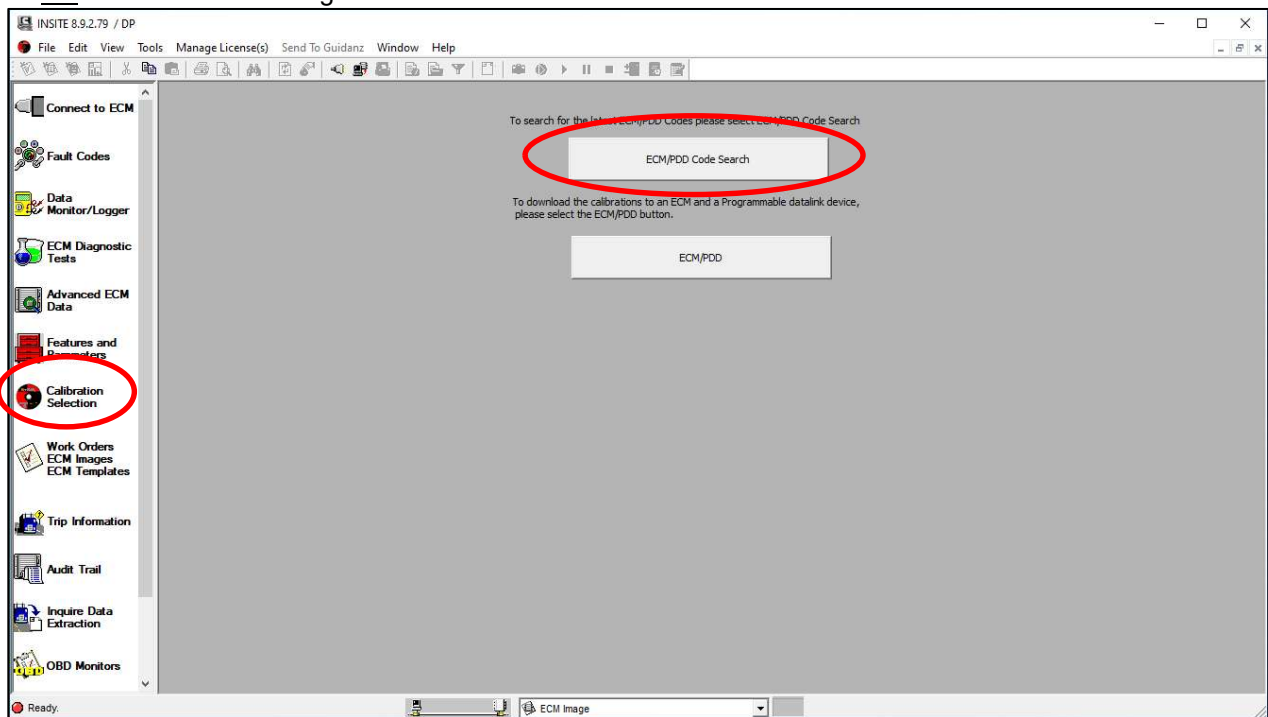

**Figure 19**

29. Enter the original production ECM code and select search. See figure 20.

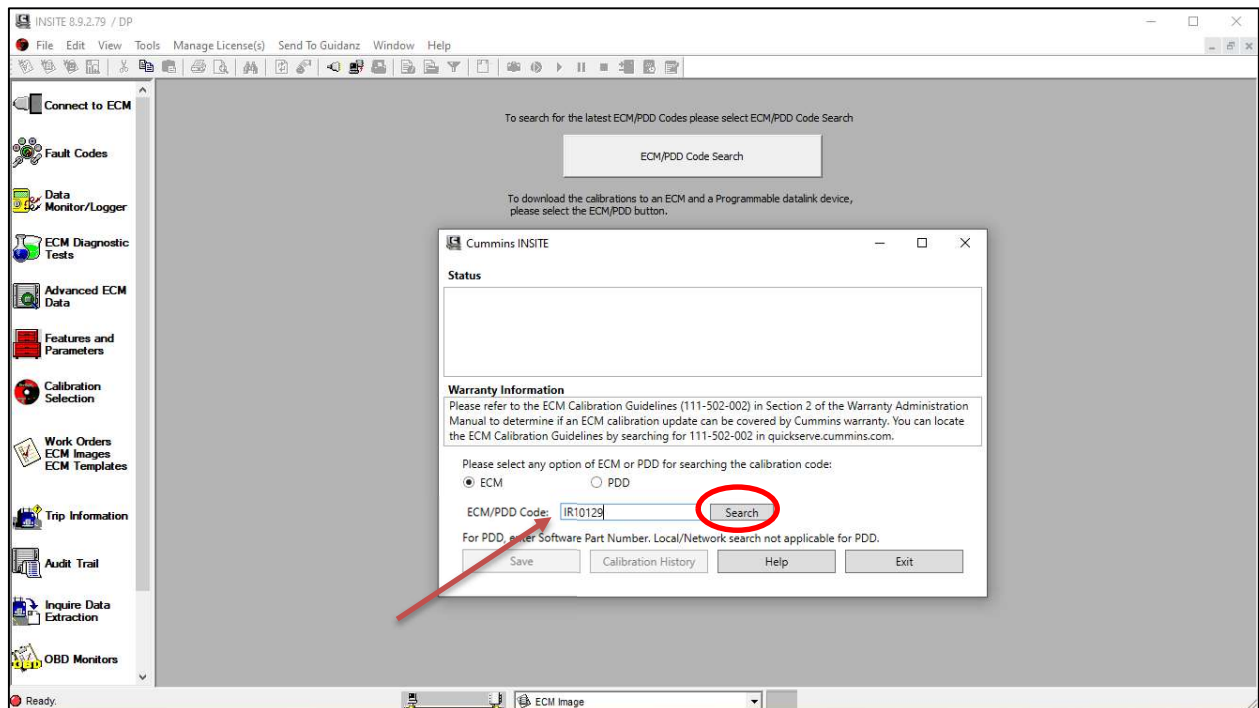

**Figure 20**

30. Select Save to download the calibration file to your laptop. See figure 21.

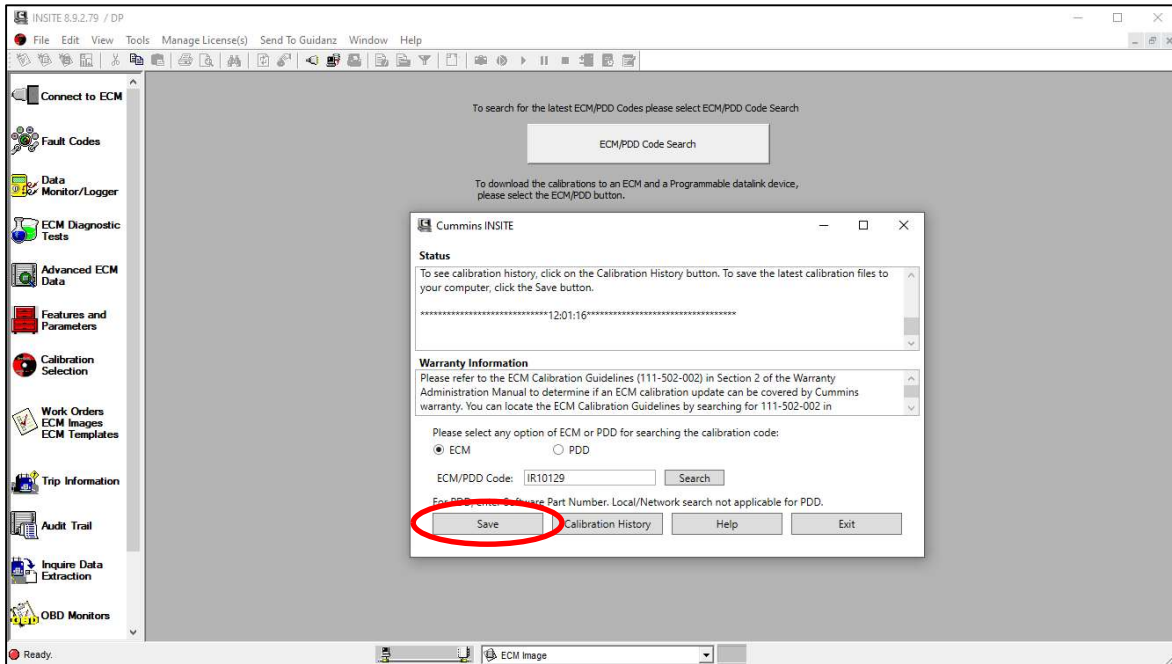

**Figure 21**

31. Confirmation the file was successfully saved to the laptop. Select Exit. See figure 22

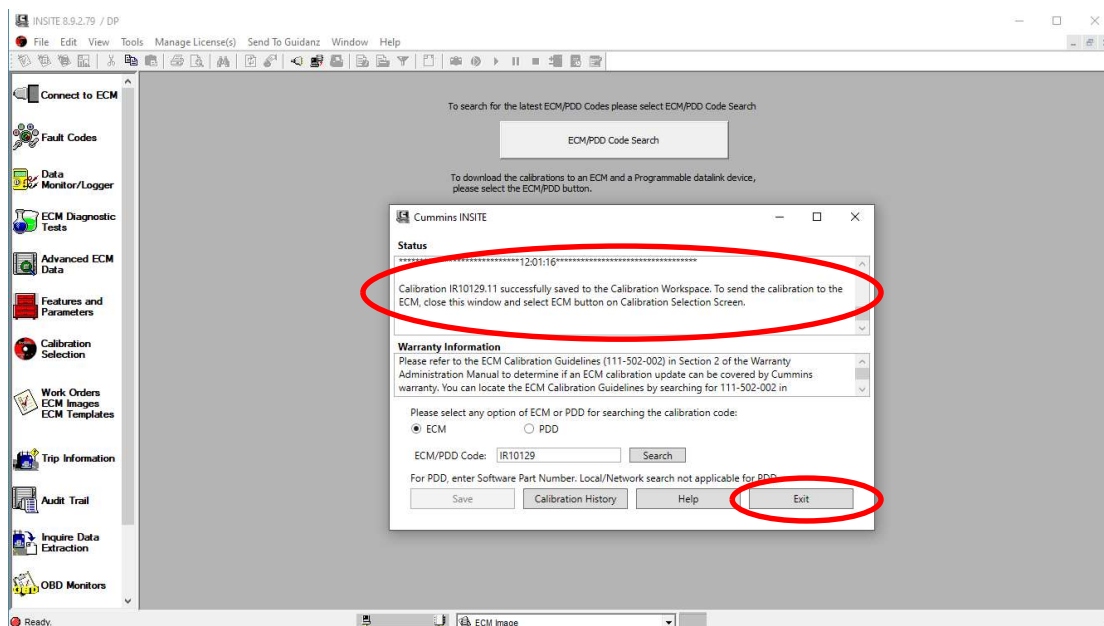

**Figure 22**

32. Reconnect Insite to the engine ECM.

33. Select ECM/PDD on the Calibration Selection page. See figure 23.

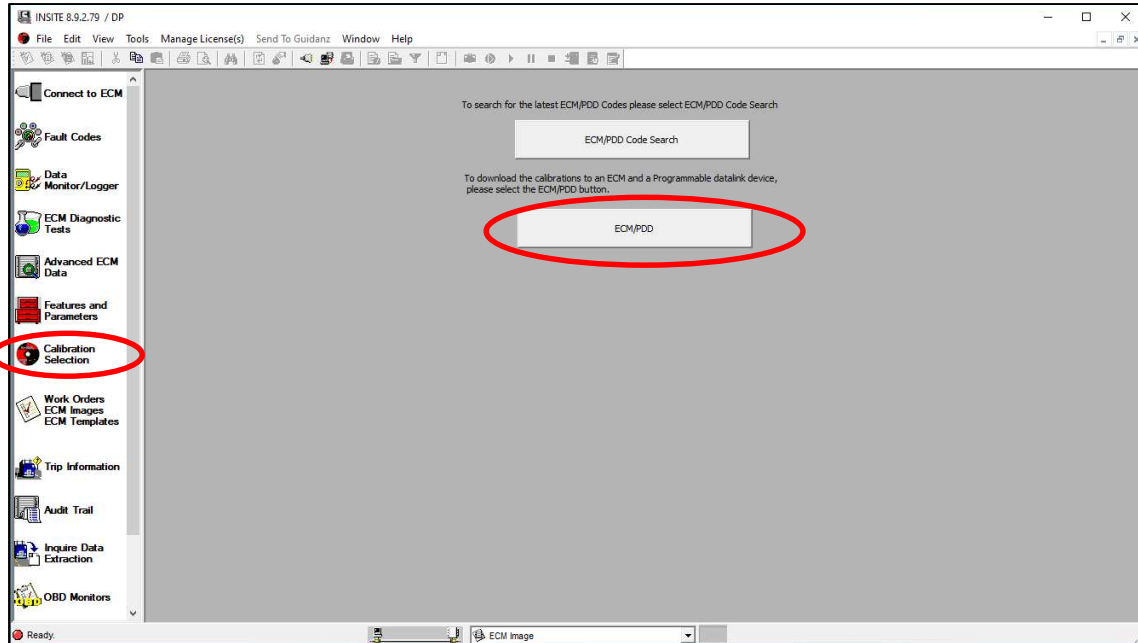

**Figure 23**

34. Expand the Work Space files until the ECM part number is shown. Double click on the ECM part number. See figure 24.

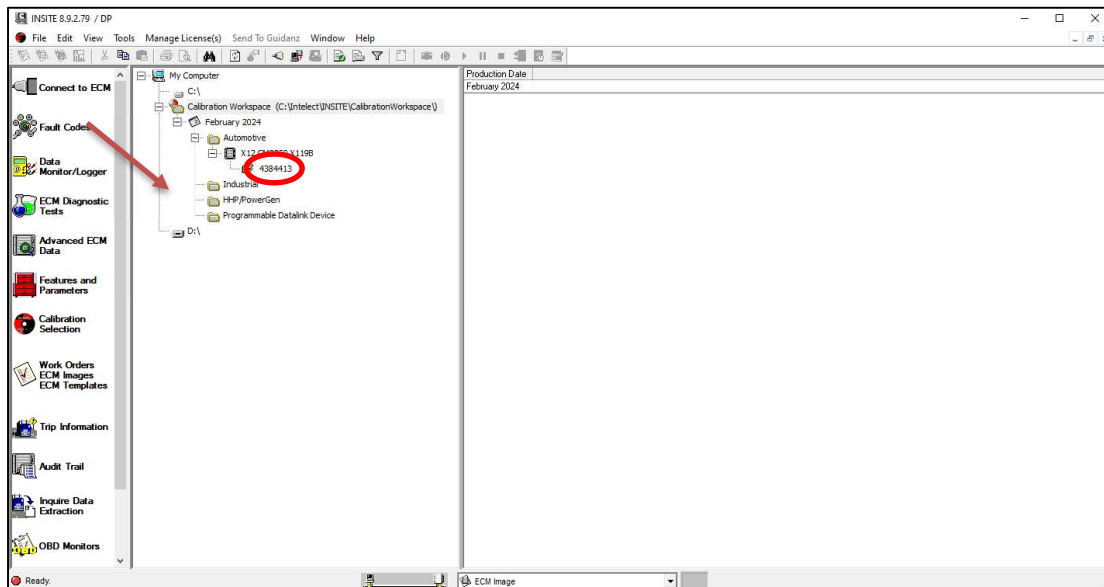

**Figure 24**

Note: If a Certification Code Selection window pops up, select 'Move All' and click OK. See figure 25.

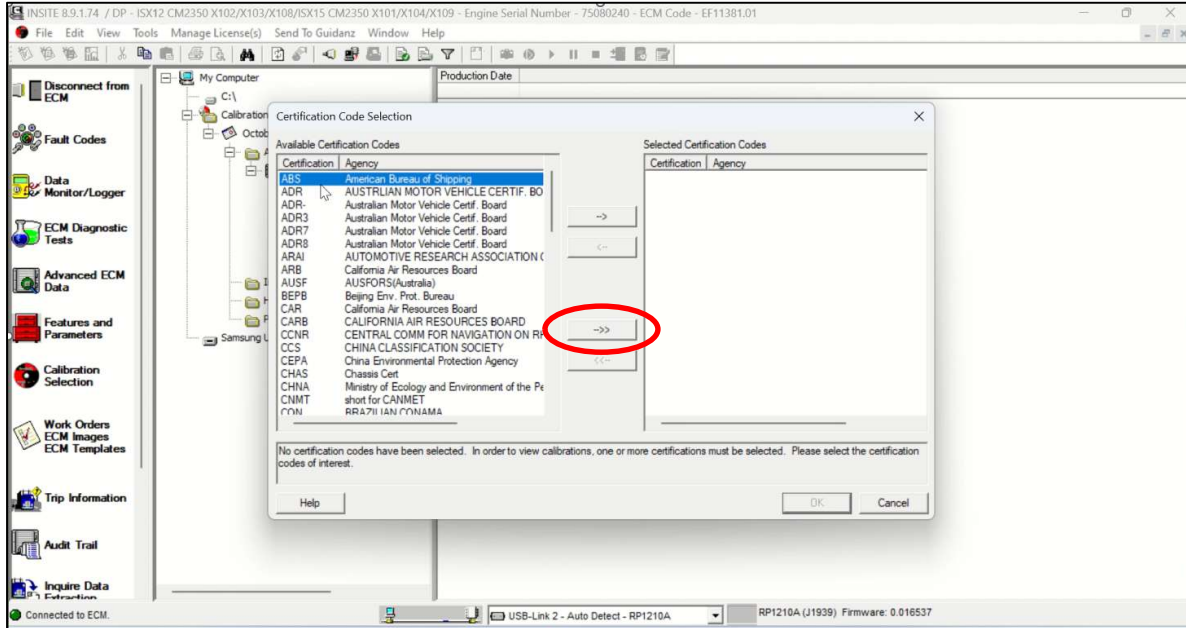

**Figure 25**

35. Scroll to the ECM code for your engine. A small hard drive symbol will show under the green check mark. See figure 26. Double click your ECM code and the ECM Download Calibration Wizard will launch.

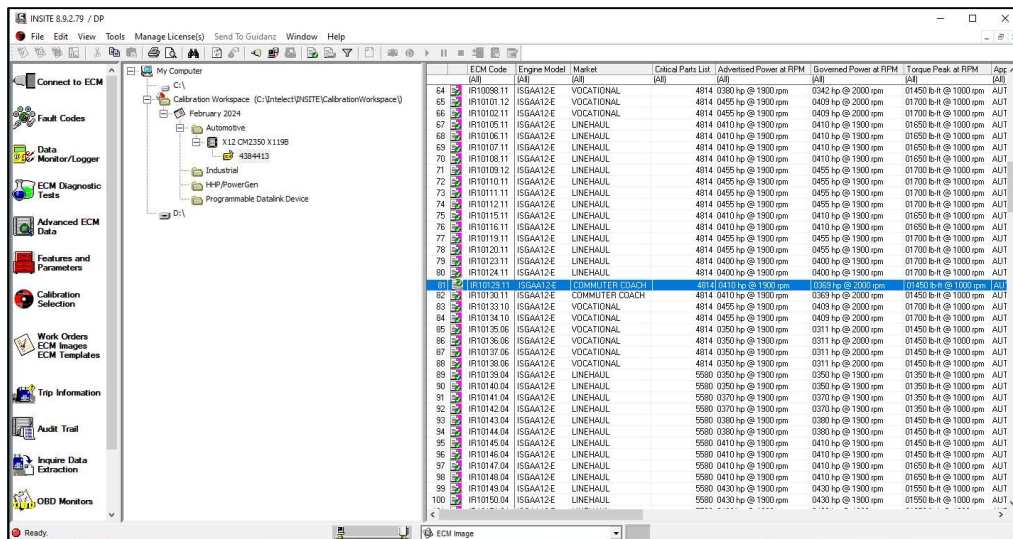

**Figure 26**

36. Select Next on the ECM Download Calibration Wizard. See figure 27.

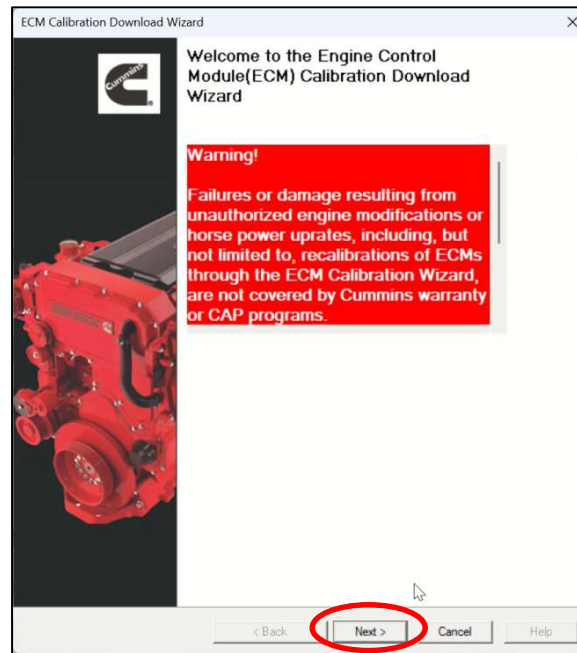

**Figure 27**

37. Verify the Save/Restore Adjustable Parameters has a check mark. Select Next. See figure 28.

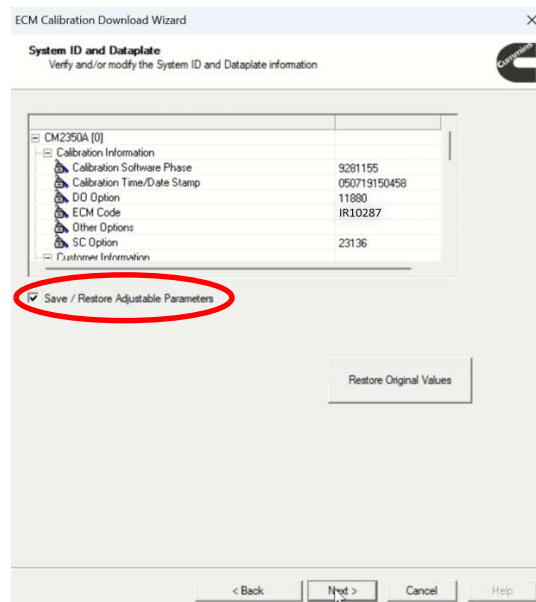

**Figure 28**

38. Verify the ECM code desired is listed and select next. See figure 29.

**Note:** Because the bypass calibration being removed has been obsoleted by Cummins, Insite will not require a Fleet Calibration (fleet count) to change the calibration code. If Insite requests a fleet count, confirm your requested ECM calibration code is correct to the engine serial number. See figure 29.

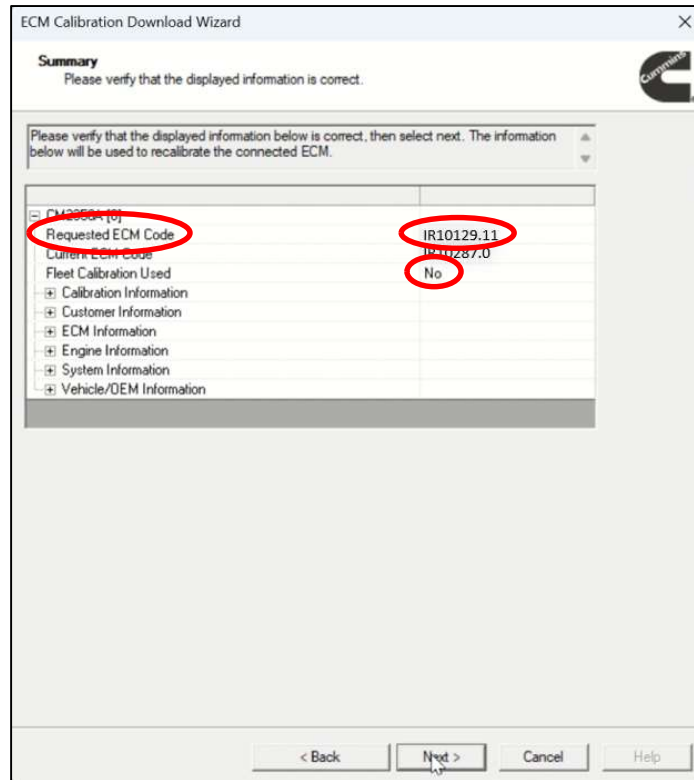

**Figure 29**

39. Adjustment Confirmation. Before selecting OK, ensure the vehicle batteries are sufficient to provide power throughout the calibration sequence, about 20 minutes. If the vehicle is equipped with engine radiator Efans, disable the power source to the Efans. The ECM will go off-line and the Efan controller will run the fans at full speed with no connection to the engine ECM. Select OK to start the calibration sequence. See figure 30.

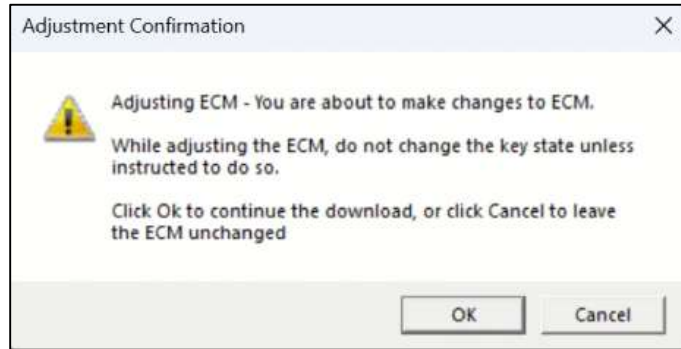

**Figure 30**

40. The programming sequence will take about 20 mins. There will be prompts to turn the ignition switch off and on throughout the programming sequence. See figure 31.

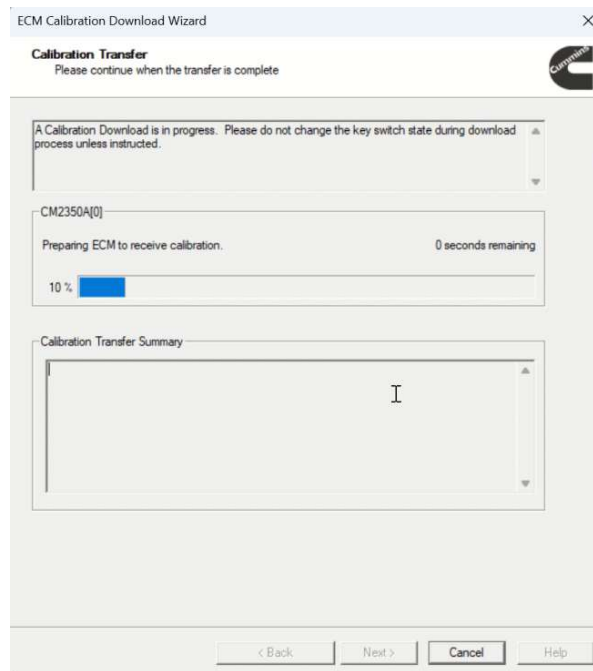

**Figure 31**

41. Select Next when the calibration is complete. See Figure 32.

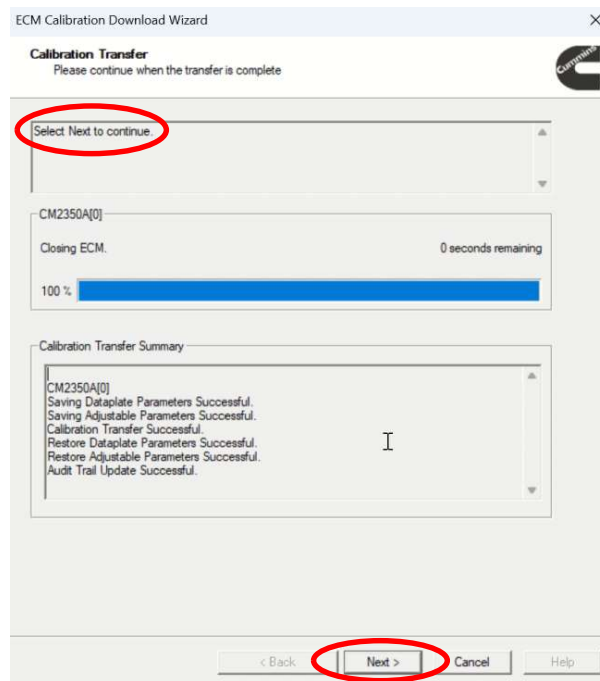

**Figure 32**

42. Select Finish on the next screen to close the ECM Calibration Download Wizard. See figure 33.

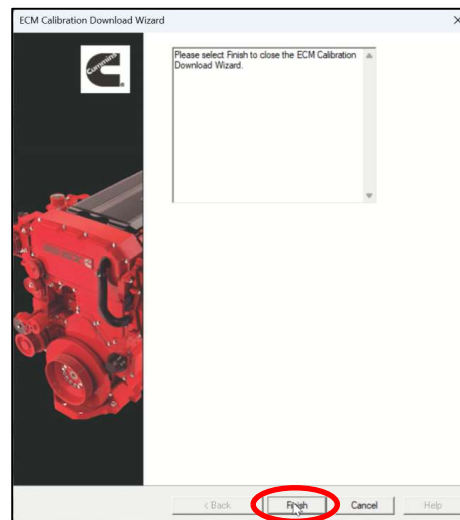

**Figure 33**

- 43. ECM calibration complete.
- 44. Enable the Efans if disabled for programming.
- 45. Clear engine area for personnel, start engine and check for any active codes.
- 46. Disconnect Cummins Insite and turn off the ignition switch.



**NEW FLYER**

**INSTRUCTION TO SERVICE**

- 47. Turn the main battery disconnect switch to the “OFF” position.
- 48. Install Cummins decal pn 5297400 on the engine valve cover next to the data plate.
- 49. Remove wheel chocks.
- 50. Turn on the main battery disconnect.
- 51. Return vehicle to service.
- 52. Provide the customer with Cummins PN 4310621, Emissions Campaign – Proof of Correction.

<b>LABOUR ESTIMATE</b>				
	Operation	Number of Technician(s)	Hours	Labor Time T X HR
1	Programming engine ECM	1	1	1
2	Replace DEF Tank Sensor	1	2.5	2.5

<b>PARTS REQUIRED</b>					
Item	Part Number	Description	Qty. per Coach	Units	Notes
1	6490647	SENSOR KIT-DEF 22 GEN 7	1 AR	Ea	As Required
2	5297400	Cummins Valve Cover Decal	1	Ea	
3	4310621	Cummins Emission Campaign – Proof of Correction	1	Ea	

<b>SPECIAL TOOLS REQUIRED</b>					
Item	Part Number	Description	Qty.	Units	Notes
1	NPN	O-ring lubricant	AR		Source Locally
2	NPN	Cummins Insite Pro Diag Software	AR		