



Ford Motor Company  
Customer Service Division  
PO Box 1904  
Dearborn, Michigan 48121

February 2026

Customer Satisfaction Program 25N10

Mr. John Sample  
123 Main Street  
Anywhere, USA 12345

12345678901234567

At Ford Motor Company, we are committed not only to building high-quality, dependable products but also to building a community of happy, satisfied customers. To demonstrate that commitment, we are providing a no-charge Customer Satisfaction Program for your vehicle.

**Why are you receiving this notice?**

If your vehicle is upfitted with an Aerial Bucket Second Unit Body (SUB), the SUB may cause stress on the frame rail during use, which may lead to cracks in the frame rail. We are pleased to let you know that Ford Motor Company is providing a one-time repair on the frame if your dealer determines a replacement is required, and if your vehicle is within certain time and mileage limitations. This program does not apply if you have a different second unit body attached to your truck.

**What is the effect?**

Under certain conditions, the frame rail may crack on Aerial Bucket SUB-equipped vehicles.

**What will Ford and your dealer do?**

**Parts are available if your vehicle requires a repair.** Please confirm parts availability with your dealer when scheduling an appointment. Under the terms of the program, a one-time replacement of covered components, if required, is available for a total of 5 years or 150,000 miles from the warranty start date, whichever occurs first, free of charge (parts and labor). If your vehicle has already exceeded either time or mileage limits listed above, this one-time repair offer will remain available through February 9, 2027. Coverage is automatically transferred to subsequent owners. This is a one-time repair program.

**What should you do?**

You do not need to return to your dealer for this repair unless you have a cracked frame. Please keep this letter as a reminder of the one-time repair offer for your frame. If the frame requires replacement, and your vehicle is within the indicated time/mileage limitations, contact your dealer to schedule a service appointment for Customer Satisfaction Program 25N10. Your dealer will replace the part at no charge.

If you do not already have a servicing dealer, you can access [ford.com/support](https://ford.com/support) for dealer addresses, maps, and driving instructions.

**Have you previously paid for this repair?**

If you paid to have this service done before the date of this letter, you may be eligible for a refund. Refunds will only be provided for services related to repair description. To verify eligibility and expedite reimbursement, give your paid original receipt to your dealer before August 9, 2026. To avoid delays, do not send receipts to Ford Motor Company.

**What if you no longer own this vehicle?**

If you no longer own this vehicle and have an address for the current owner, please forward this letter to the new owner. You received this notice because our records indicate that you are the current owner or lessee.

**Can we assist you further?**

If you have difficulties getting your vehicle repaired promptly and without charge, please contact your dealership's Service Manager for assistance.

If you have questions or concerns, please contact our **Ford Recall Assistance Center (RAC) at 1-866-436-7332** and one of our representatives will be happy to assist you. The RAC is open on weekdays from 8:30 AM – 7:00 PM (Eastern Time). TTY/TDD users, please contact the RAC at the number listed using the Telecommunication Relay Service by dialing 711.

If you wish to contact us through the internet, our address is [ford.com/support](https://ford.com/support).

**To view the letter in Spanish**

visit: [fordtranslatehub.com](https://fordtranslatehub.com)

**Para ver la carta en español**

viste: [fordtranslatehub.com](https://fordtranslatehub.com)



Open the QR reader application or the camera on your smartphone. Point it at the QR code, then tap the banner that appears on your device. Follow the instructions on the screen to finish.

Abre la aplicación del lector QR o la cámara de tu smartphone. Apunta al código o QR y pulsa el banner que aparece en tu dispositivo. Sigue las instrucciones en pantalla para terminar.

As part of the Ford community, we appreciate your attention to this important matter and your continued loyalty.

Customer Service Division



Ford Motor Company  
División de Servicio al Cliente  
PO Box 1904  
Dearborn, Michigan 48121

Febrero 2026

Programa de satisfacción del cliente 25N10

Sr. Juan Pérez  
Calle Principal 123  
Ciudad, EE. UU. 12345

12345678901234567

El compromiso de Ford Motor Company no es solo fabricar productos confiables y de alta calidad, sino también lograr la plena satisfacción del cliente. Para demostrar este compromiso, le ofrecemos el Programa de satisfacción del cliente sin costo alguno para su vehículo.

- ¿Por qué recibe este aviso?** Si su vehículo está equipado con una segunda unidad de carrocería (SUB) con asiento individual aéreo, la SUB podría causar tensión en el riel del bastidor durante el uso, lo que puede generar grietas en el riel del bastidor. Nos es muy grato informarle que Ford Motor Company ofrece una reparación única del bastidor si su concesionario determina que se requiere un reemplazo y si su vehículo se encuentra dentro de ciertos límites de tiempo y millaje. Este programa no aplica si tiene una segunda unidad de carrocería diferente instalada en su camión.
- ¿Cuál es el efecto?** En determinadas condiciones, el larguero del bastidor se podría agrietar en vehículos equipados con SUB con asiento aéreo.
- ¿Qué medidas adoptarán Ford y su concesionario?** **Las piezas se encuentran disponibles si su vehículo requiere una reparación.** Confirme la disponibilidad de piezas con su concesionario al programar una cita. Según los términos del programa, se encuentra disponible un reemplazo único de los componentes cubiertos, si es necesario, por un total de 5 años o 150,000 millas a partir de la fecha de inicio de la garantía, lo que ocurra primero, sin costo alguno (piezas y mano de obra). Si su vehículo ya excedió los límites de tiempo o millaje anteriormente mencionados, esta oferta de reparación única permanecerá disponible hasta el 9 de febrero de 2027. La cobertura se transfiere automáticamente a los siguientes propietarios. Este es un programa de reparación única.
- ¿Qué debe hacer?** No debe regresar al concesionario para realizar esta reparación a menos que tenga un bastidor agrietado. Conserve esta carta como recordatorio de esta oferta de reparación única para su bastidor. Si es necesario reemplazar el bastidor y su vehículo se encuentra dentro de los límites de

**¿Qué debe hacer?  
(continuación)**

tiempo o millaje indicados, comuníquese con su concesionario para programar una cita de servicio para realizar el Programa de satisfacción del cliente 25N10. Su distribuidor reemplazará las piezas sin costo alguno. Si aún no tiene un concesionario para realizar el servicio, puede acceder a [ford.com/support](https://ford.com/support) para conocer las direcciones de los concesionarios, ver mapas y obtener las instrucciones para llegar.

**¿Pagó anteriormente por esta reparación?**

Si pagó por este servicio antes de la fecha de esta carta, es posible que cumpla con los requisitos para solicitar un reembolso. Solo se otorgarán reembolsos por servicios relacionados con la reparación que se describe. Para comprobar si cumple con los requisitos y agilizar el reembolso, entregue el recibo de pago original a su concesionario antes del 9 de agosto de 2026. Para evitar demoras, no envíe recibos a Ford Motor Company.

**¿Qué pasa si ya no es el propietario del vehículo?**

Si usted ya no es el propietario del vehículo y tiene la dirección del propietario actual, le solicitamos que le reenvíe esta carta. Recibió este aviso porque nuestros registros indican que es el propietario o arrendatario actual.

**¿Podemos hacer algo más por usted?**

Si tiene problemas para reparar su vehículo de inmediato y sin costo alguno, comuníquese con el Gerente de Servicio de su concesionario para solicitar ayuda.

si tiene dudas o preguntas, comuníquese con nuestro **Centro de Asistencia de Campañas Ford (RAC) al 1-866-436-7332** y uno de nuestros representantes con gusto lo atenderá. El RAC está abierto de lunes a viernes de 8:30 a. m. a 7:00 p. m. (hora del este). Si es usuario de TTY/TDD, comuníquese con el RAC al número que se menciona, mediante el servicio de retransmisión de telecomunicaciones, para esto, marque el 711.

Si desea comunicarse con nosotros a través de Internet, nuestra dirección es [ford.com/support](https://ford.com/support).

**Para ver la carta en español** visite: [fordtranslatehub.com](https://fordtranslatehub.com)

**Para ver la carta en español** visite: [fordtranslatehub.com](https://fordtranslatehub.com)



Abra la aplicación de lector de QR o la cámara de su smartphone. Apunte al código QR y luego toque el aviso que aparece en su dispositivo. Siga las instrucciones en la pantalla para finalizar.

Abre la aplicación del lector QR o la cámara de tu smartphone. Apunte al código QR y pulse el banner que aparece en su dispositivo. Siga las instrucciones en pantalla para finalizar.

Como parte de la comunidad Ford, agradecemos su atención en este asunto sumamente importante y su lealtad.

División de Servicio al Cliente



Service Engineering Operations  
Customer Service Division

Ford Motor Company  
PO Box 1904  
Dearborn, Michigan 48121

February 11, 2026

**TO:** All U.S. Ford and Lincoln Dealers

**SUBJECT: Customer Satisfaction Program 25N10**  
Certain 2017-2025 F-450 – F-600 Super Duty Chassis Cab Upfitted with an Aerial Bucket  
Frame Rail Crack

**PROGRAM TERMS**

This program provides a no-cost repair (if needed) to the frame assembly for 5 years of service or 150,000 miles from the warranty start date of the vehicle, whichever occurs first.

This is a one-time repair program.

If a vehicle has already exceeded either the time or mileage limits, this no-cost, one-time repair will remain available through February 11, 2027.

Coverage is automatically transferred to subsequent owners.

**AFFECTED VEHICLES (U.S. Population Of Affected Vehicles 126):**

Vehicle	Model Year	Assembly Plant	Build Date Range
F-450 – F-600 Super Duty	2017-2025	Kentucky Truck	July 22, 2016, through April 6, 2025
F-450 – F-600 Super Duty	2017-2025	Ohio Assembly	August 2, 2016, through April 25, 2025

Affected vehicles are identified in OASIS.

**REASON FOR PROVIDING A NO-COST, ONE-TIME REPAIR**

In some of the affected vehicles the Aerial Bucket Second Unit Body (SUB) upfits could cause stress points on the frame rail. Over time, this stress could cause a crack in the frame rail.

**SERVICE ACTION**

If an affected vehicle exhibits this condition, dealers are to replace the frame assembly at no charge to the vehicle owner. For new vehicle storage guidelines, refer to EFC13033, Storage Guidelines for New Vehicles.

**FSA PROGRAM OPTIONS**

Program Option	Eligibility	Comments
Mobile Repair	No	See the <b>Mobile Service Repair Assessment Level</b> section below, if applicable.
Over-the-Air (OTA) Update	No	See the <b>Over-The-Air (OTA) Updates</b> section of the FSA Policy Document, if applicable.
Rentals	No	See the <b>Rental Vehicles</b> section below, if applicable.

Alternative Transportation Available	No	See the <b>Alternate Transportation</b> section in the FSA Policy Document.
Pickup & Delivery (PDL)	No	See the <b>Pickup &amp; Delivery</b> section in the FSA Policy document.
Towing	Yes	See <b>Claims Preparation and Submission</b> section below, if applicable.
Essential Special Service Tools (ESST)	No	See <b>Technical Instructions</b> and/or <b>Workshop Manual (WSM)</b> as needed.
Administrative Allowance	No	See the <b>Administrative Allowance</b> section in the FSA Policy Document, and if applicable, the <b>Labor Allowances</b> table below.
Owner Refunds	Yes	See <b>Owner Refunds</b> section below, if applicable.
Photo Submission	Yes	See <b>Repair Photo Submission</b> section below, if applicable.

**Note:** For further information on certain Program Options above, see the corresponding section within the FSA Policy Document.

### **OWNER NOTIFICATION MAILING SCHEDULE**

Owner Letters are expected to be mailed the week of February 16, 2026, or sooner. Dealers should repair any affected vehicles that have a cracked frame, regardless of whether the customer has received a letter.

### **ATTACHMENTS**

- Technical Instructions
- Owner Notification Letter

### **REFERENCE MATERIAL**

- Warranty & Policy Manual (located on FMCDealer Warranty Portal Page):  
[www.fmcdealer.dealerconnection.com/content/fmcdealer/us/en/parts\\_service/wty.html](http://www.fmcdealer.dealerconnection.com/content/fmcdealer/us/en/parts_service/wty.html)
- FSA Policy Document (located on FMCDealer FSA Resources Page for Ford and Lincoln dealerships):  
[www.fmcdealer.dealerconnection.com/content/fmcdealer/us/en/parts\\_service/fsa/rsc.html](http://www.fmcdealer.dealerconnection.com/content/fmcdealer/us/en/parts_service/fsa/rsc.html)
- FSA Policy Document (located on the Fleet SharePoint site for Fleets with in-house warranty):  
<https://azureford.sharepoint.com/sites/OneWarrantySolution/usfleet/SitePages/Home.aspx>

### **QUESTIONS & ASSISTANCE**

For questions and assistance, contact the Special Service Support Center (SSSC) via the SSSC Web Contact Site. The SSSC Web Contact Site can be accessed through the Professional Technician System (PTS) website using the SSSC link listed at the bottom of the OASIS VIN report screen or listed under the SSSC tab.

Customer Service Division

**Customer Satisfaction Program 25N10****MOBILE SERVICE REPAIR ASSESSMENT LEVEL**

 - Not a Mobile Service Repair

**OASIS ACTIVATION**

OASIS will be activated on February 11, 2026.

**FSA VIN LISTS ACTIVATION**

FSA VIN Lists will not be activated for this service action.

**SOLD & STOCK VEHICLES**

- For more information regarding dealership obligations to identify and repair sold and stock vehicles, consult Ford's Policy Document For Field Service Actions, which can be found in the FSA Landing page on PTS.

**BRANDED / SALVAGED TITLE VEHICLES**

Vehicles with canceled warranties are not eligible for this service action.

**OWNER REFUNDS**

- This refund offer expires August 11, 2026.
- Refunds will only be provided for the cost associated with the frame assembly repair or replacement.
- Refer to the Warranty and Policy Manual regarding Customer/Dealer Refunds.

**RENTAL VEHICLES**

Rental vehicles are not approved for this program.

**TOWING**

If towing is required, dealers are authorized to claim up to a maximum value of \$1,200 to provide towing services for this program.

**REPAIR PHOTO SUBMISSION**

Ford has requested photo evidence prior to performing the repair for this FSA.

- The SSSC must provide approval prior to performing the repair.
- Contact the SSSC and upload the necessary photos or copy of documentation as an attachment for review. Photos of the vehicle, VIN number, mileage, and frame crack are requested. This can be done in two ways:
  - Directly in the SSSC contact request form while submitting your contact on your desktop.
  - Via PTS Mobile under the Images / Files Upload menu selection.
    - You should select SSSC in the sub-menu and ensure your P&A code is correct. Upload the photo(s) by selecting the appropriate FSA with the option to use a prior contact ID. These photo(s) will be associated with your SSSC contact during submission.
    - If you have not submitted a SSSC contact yet, then you can still upload the photo(s) via PTS Mobile, and the photo(s) will be available when opening your SSSC contact for this VIN and recall.
- Upon approval, the SSSC will provide an approval code that must be used for claiming.
  - After completing the report entry form, you can upload a maximum of 5 attachments at once.

**Customer Satisfaction Program 25N10****ADDITIONAL REPAIR (LABOR TIME AND/OR PARTS)**

Additional repairs identified as necessary to complete the FSA should be managed as follows:

- For related damage and access time requirements, refer to the Warranty and Policy Manual / Section 6 – Ford & Lincoln Program Policies / General Information & Special Circumstances for FSA's / Related Damage.
- **For vehicles within new vehicle bumper-to-bumper warranty coverage, no SSSC approval is required**, although related damage must be on a separate repair line with the "Related Damage" radio button checked.
  - Ford vehicles – 3 years or 36,000 miles
- **For vehicles outside new vehicle bumper-to-bumper warranty coverage:**
  - Submit an Approval Request to the SSSC Web Contact Site before completing the repair.

**CLAIMS PREPARATION AND SUBMISSION**

- **Technician Competency Requirement:** The STST Competency 10 certification requirement in the U.S. market only will be enforced starting with repair orders opened on or after August 31, 2024. FSA repairs will be rejected, and the claim will not be paid if the repairing technician is not certified in STST Competency 10 FSA. See EFC15936 for more details.
  - **Note:** All repairs for this program should be claimed using the claim entry direction below regardless if the vehicle is still under the New Vehicle Limited Warranty.
    - Service Part Warranty (SPW) and/or Ford/Lincoln Loyalty Plans (ESP) eligible vehicles – Claim repairs to FSA 25N10 if the vehicle is still within time and mileage limits.
  - **Claim Entry:** Enter claims using Dealer Management System (DMS) or One Warranty Solution (OWS) online.
    - When entering claims:
      - Claim type 31: Field Service Action
      - Sub Code: 25N10
      - Customer Concern Code (CCC): N59 – Other squeak/rattle (excludes wind noise)
      - Condition Code (CC): 01 – Broken/Cracked
      - Causal Part Number: 5005, Quantity 0
    - For additional claims preparation and submission information, refer to the Recall and Customer Satisfaction Program (CSP) Repairs in the OWS User Guide.
  - **Related Damage/Additional labor and/or parts:** Must be claimed as Related Damage on a separate repair line from the FSA with the same claim type and subcode as described in Claim Entry above.
- IMPORTANT:** Click the Related Damage Indicator radio button.
- **Refunds:** Submit refunds on a separate repair line.
    - Program Code: 25N10
    - Misc. Expense: REFUND
    - Misc. Expense: ADMIN
    - Misc. Expense: 0.2 Hrs.
  - Multiple refunds should be submitted on one repair line, and the invoice details for each repair should be detailed in the comments section of the claim.

**Customer Satisfaction Program 25N10**

- **Provision for Locally Obtained Supplies:** Includes top off fluids, parts cleaner, and penetrating fluid. Submit on the same line as the repair.
  - Program Code: 25N10
  - Misc. Expense: OTHER
  - Misc. Expense: Claim up to \$50.00
- **Provision for Towing:** Dealers are authorized to claim up to a maximum value of \$1200 to provide towing services to and from the sublet repair shop. Submit on the same line as the repair.
  - Program Code: 25N10
  - Misc. Expense: TOW
  - Misc. Expense: Claim up to \$1,200

Customer Satisfaction Program 25N10

**LABOR ALLOWANCES**

Description	Labor Operation	Labor Time Hour(s)
<p>Inspect and verify the frame is cracked. Replace frame assembly. Labor time includes exhaust hanger modification, DEF pressure line, and wire harness re-routing. <b>This labor operation will close the FSA.</b></p> <p><b>This labor operation cannot be claimed with MTFSAOSL</b></p> <p><b>This labor operation can be claimed with MT25N1C or MTFSAOREMOTE</b></p>	MT25N10B	Up to 99 Hours
<p><b>Sublet Repair - Frame replacement.</b> Labor time includes exhaust hanger modification, DEF pressure line, and wire harness re-routing. Follow the Warranty and Policy manual for sublet repair guidelines. If additional time is needed, contact SSSC.</p> <p><b>This labor operation will close the FSA. This labor operation cannot be claimed with MT25N10B</b></p> <p><b>This labor operation can be claimed with MT25N1C or MTFSAOREMOTE</b></p>	MTFSAOSL	Up to 99 Hours

**SUPPLEMENTAL LABOR ALLOWANCES** **These labor operation codes DO NOT close the FSA.**

Description	Labor Operation	Labor Time Hour(s)
<p><b>Removal and Installation of the second unit body.</b> If additional time is needed, contact SSSC.</p> <p><b>This labor operation cannot be claimed with MTFSAOREMOTE</b></p>	MT25N10C	Up to 80 Hours
<p><b>Sublet Repair - Removal and Installation of the second unit body:</b> Follow the Warranty and Policy manual for sublet repair guidelines. If additional time is needed, contact SSSC.</p> <p><b>This labor operation cannot be claimed with MT25N10C</b></p> <p><b>This labor operation can be claimed with MTFSAOSL or MT25N10B</b></p>	MTFSAOREMOTE	Up to 80 Hours
<p>Time allowed to submit photos.</p> <ol style="list-style-type: none"> <li>1. Attach a photo of the vehicle mileage.</li> <li>2. Attach a photo of the door tag showing VIN.</li> <li>3. Attach a photo of the vehicle.</li> <li>4. Attach a photo(s) of the frame crack. Refer to the technical instructions for additional details</li> </ol>	25N10ZZ	0.2 Hour

Customer Satisfaction Program 25N10

**PARTS REQUIREMENTS / ORDERING INFORMATION**

**Restricted Part Ordering:**

To place an order for the frame assembly, submit a VIN-specific Part Order contact via the SSSC Web Contact Site.

**NOTE: Refer to the technical instructions to identify the frame by engineering part number and cross-reference with the list below. Verify through HVBoM the correct frame service part number.**

- **Do not use parts catalog systems to identify the frame part number. The frame part numbers in this bulletin contain improvements to support arial bucket trucks.**
- **SSSC approval is required for the frame assembly.**

Original Frame Engineering Part Number			
Prefix Part Number	Suffix Number	New Service Part Number	Frame Description
JC3C/KC3C/LC3C/NC3C	S*	ZC3Z-5005-C	18-22MY 169" WB LESS EXTENSION - F550 W/ PAYLOAD UPGRADE
HC3C	S*	ZC3Z-5005-D	17MY 169" WB LESS EXTENSION - F550 W/ PAYLOAD UPGRADE
JC3C/KC3C/LC3C/NC3C	SE*	ZC3Z-5005-E	18-22MY 169" WB W/ AFT AXLE FRAME EXTENSION
HC3C	SE*	ZC3Z-5005-F	17MY 169" WB W/ AFT AXLE FRAME EXTENSION
HC3C	Y*	ZC3Z-5005-J	17MY 192" WB
JC3C/KC3C/LC3C/NC3C	Y*	ZC3Z-5005-K	18-22MY 192" WB
JC3C/KC3C/LC3C/NC3C	L*	ZC3Z-5005-M	18-22MY 145" WB LESS EXT - F550 W/ PAYLOAD UPGRADE, F600
<b>Parts Requirements/Ordering Information continued on the next page.</b>			

\* Indicates an additional character following but is not used for reference purposes.

Customer Satisfaction Program 25N10

Order the parts below through normal order processing channels:

**NOTE: Order hardware below for all repairs**

Service Part Number	Claim Quantity	Package Order Quantity	Number in Package	Description
3C3Z-14A163-A	1	1	1	T-Push Pin - RH Outboard Urea Tank Wire Harness
HU5Z-14A163-B	2	2	1	Zip Tie - RH Outboard Urea Tank Wire Harness
LC3Z-14A099-K	1	1	1	Wire Shield – Rear Gas Tank
AU5Z-14A163-A	1	1	1	Tie Strap - Rear Gas Tank Wiring Harness
HU5Z-14A163-C	11	11	1	Tie Strap - Mid Ship Gas & Diesel Wiring Harness
5L5Z-14A163-AA	2	2	1	Push On Retainer Strap - Bracket Front
MC3Z-9N589-A	1	1	1	Clip - Fuel Filter Tube Support for LH Urea Line-Mid Ship Tank
NAI837X	As required misc. other			Coroplast® brand Tape (one roll will service several vehicles, pkg of 6 rolls). Available in the Rotunda RTTP program.
<b>Refer to the Workshop Manual and parts catalog for the complete list of one-time use parts and fasteners.</b>				

Order your parts requirements through normal order processing channels. To guarantee the shortest delivery time, an emergency order for parts must be placed.

**DEALER PRICE**

For the latest prices, refer to DOES II.

**PARTS RETENTION, RETURN, & SCRAPPING**

Please refer to the FSA Policy Document for any and all questions on parts.

**EXCESS STOCK RETURN**

Please refer to the FSA Policy Document for any questions regarding parts.

**REPLACED FSA PARTS INSPECTION AND SIGN OFF**

Please refer to the FSA Policy Document for any questions regarding parts.

## CERTAIN 2017-2025 F-450 - F-600 CHASSIS CAB UPFITTED WITH AN AERIAL BUCKET — FRAME RAIL CRACK

**IMPORTANT!** The Service Technician Specialty Training (STST) Competency 10 certification requirement in the U.S. market only will be enforced starting with repair orders opened on or after August 31, 2024. Field Service Action (FSA) repairs will reject and the claim will not be paid if the repairing technician is not certified in STST Competency 10 FSA. See Electronic Field Communication (EFC)15936 for more details.

### SERVICE PROCEDURE

**NOTE:** Vehicles that require frame replacements for this program are **aerial buckets ONLY**.

1. Identify and inspect the areas where the frame rail may exhibit signs of stress or a crack. See figures 1 through 6. Using compressed air, clear any debris that may be on the frame rails.

- Was a frame crack found?

**YES** - Proceed to Step 2.

**NO** - This program does not apply

2. Contact Special Service Support Center (SSSC) for approval prior to repair. Send photos of the frame crack, vehicle mileage, VIN and overall view of the vehicle when contacting the SSSC.

• Required frame crack pictures, it's helpful to have the crack cleaned and paint mark the start/stop locations of the crack (Exception being if frame is cracked in half).

1. One close up photo of the crack with a measurement scale in photo. The photo should cover an area of the frame that is about 1 foot by 1 foot.

2. Zoomed out photo of the crack to show where crack is located.



**LOCATION 1 - UPPER FRAME RAIL BEHIND CAB - See Figures 1 and 2.**

(1) Front of Vehicle.

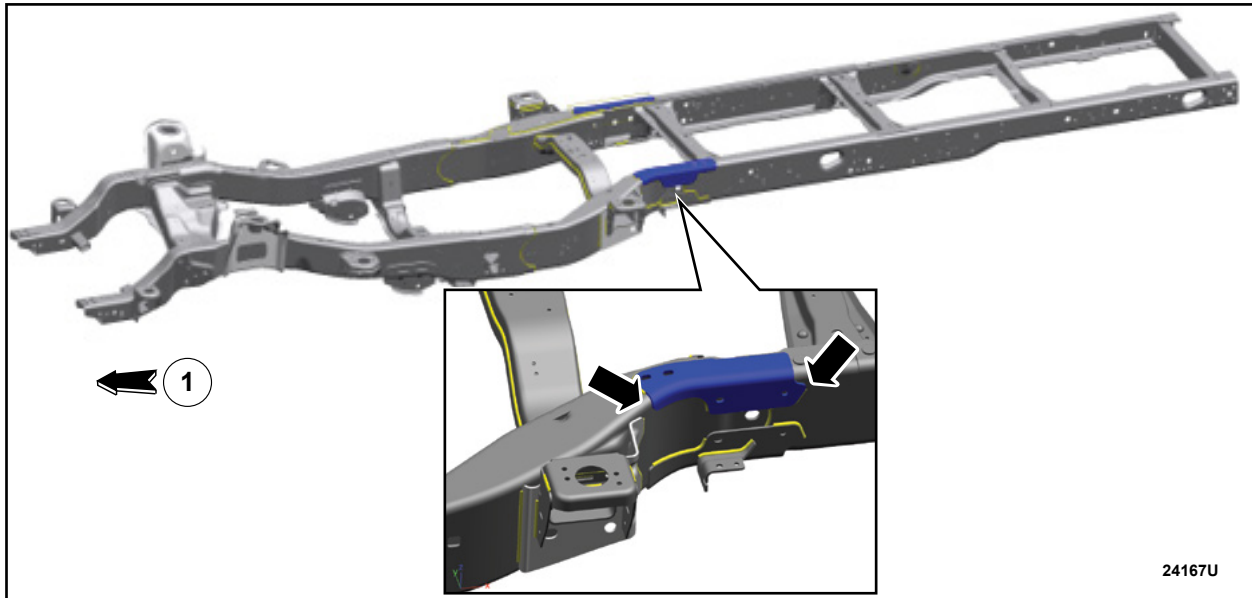

**FIGURE 1**

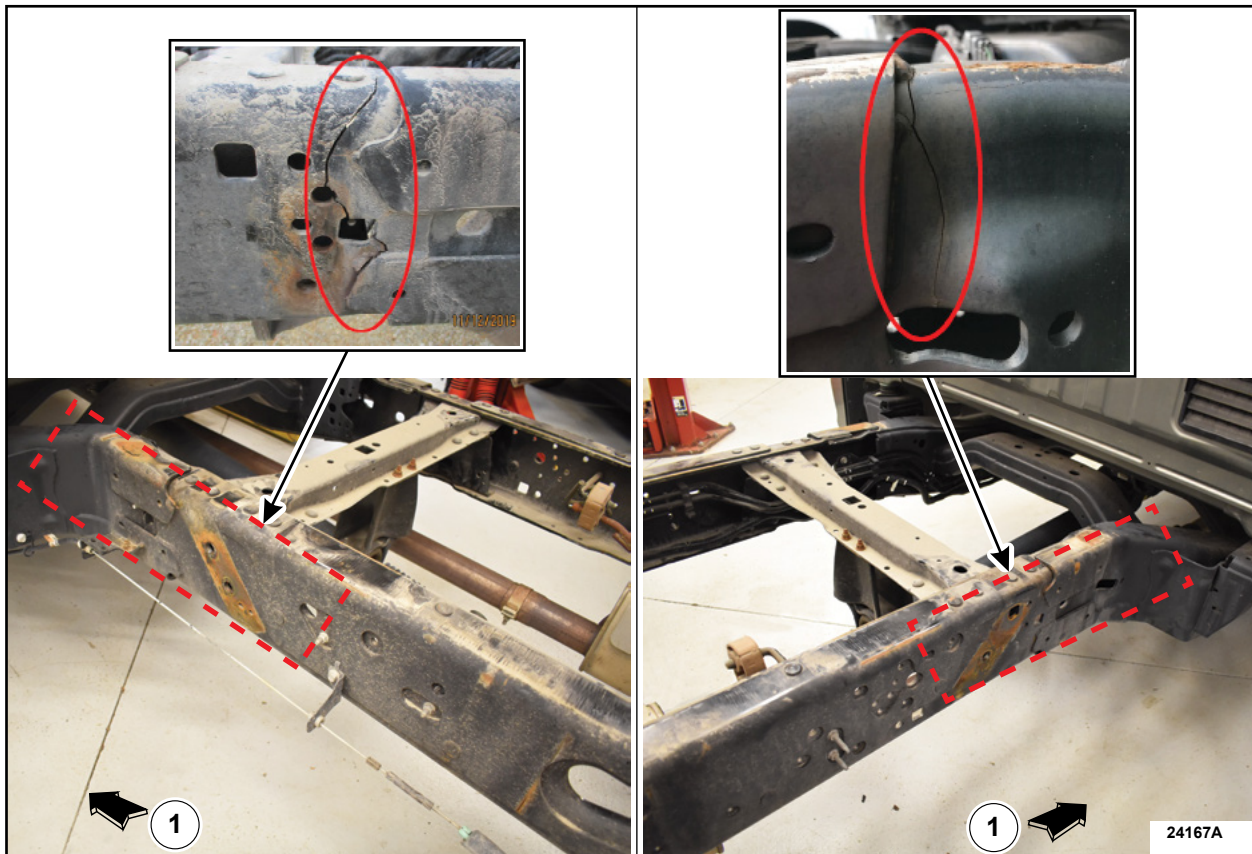

**FIGURE 2**



LOCATION 2 - FRONT FRAME RAIL TO MID RAIL WELD - See Figures 3 and 4.

(1) Front of Vehicle.

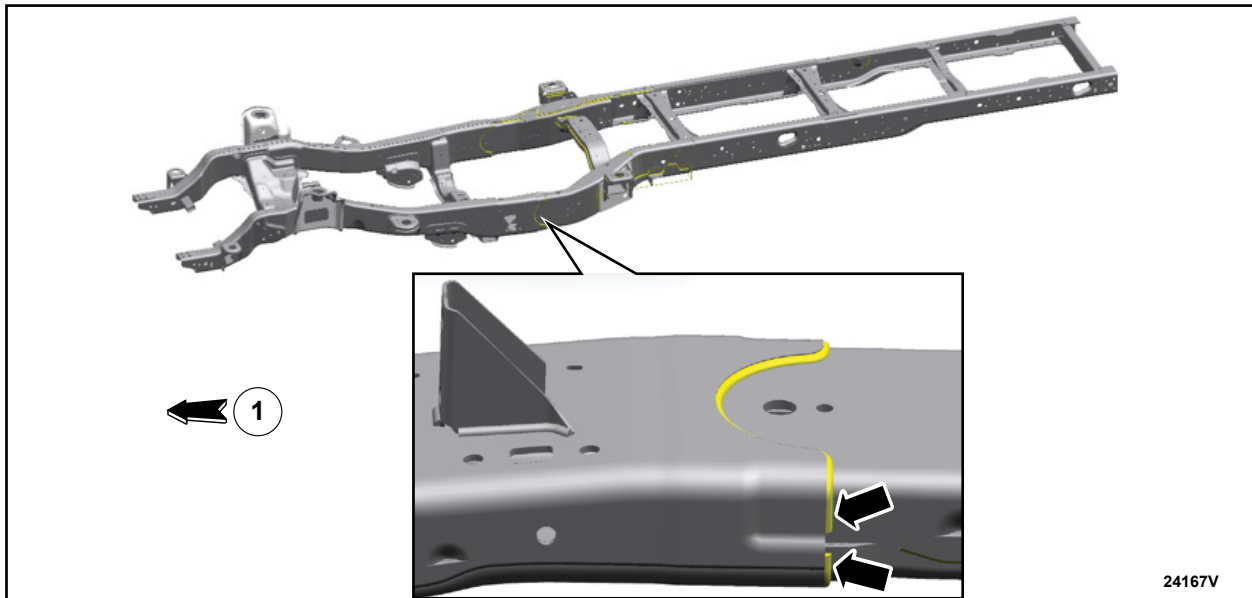

FIGURE 3

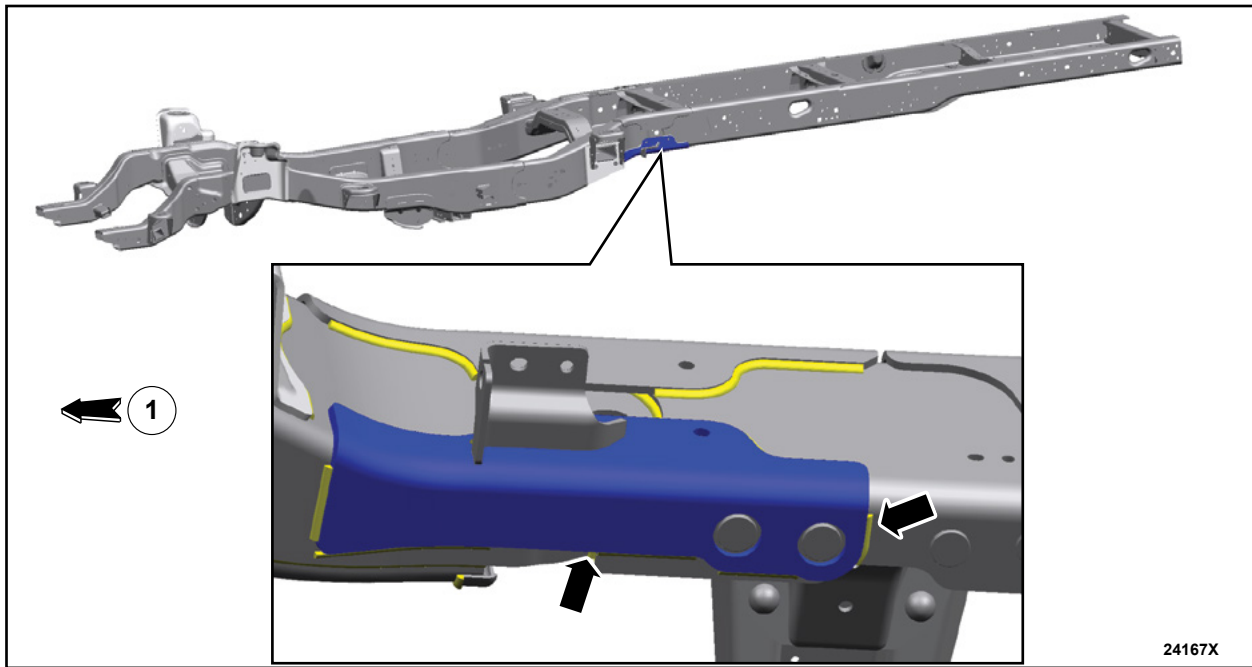

FIGURE 4



**LOCATION 3 - LOWER FRAME RAIL BEHIND CAB- See Figures 5 and 6.**

(1) Front of Vehicle.



**FIGURE 5**



**FIGURE 6**



## ORIGINAL FRAME IDENTIFICATION

**NOTE:** Refer to the Dealer Bulletin for the correct part numbers for the frame.

**NOTE:** The frame identification can be determined either by the part number label on the frame or by the Historical Vehicle Bill Of Material (HVBoM) in Online Automotive Service Information System (OASIS).

### **Frame Part Number Label Method:**

1. Locate the frame part number label. The frame part number label is located on the right-side outboard surface of the frame rail behind the transmission crossmember. See Figures 7 and 8.

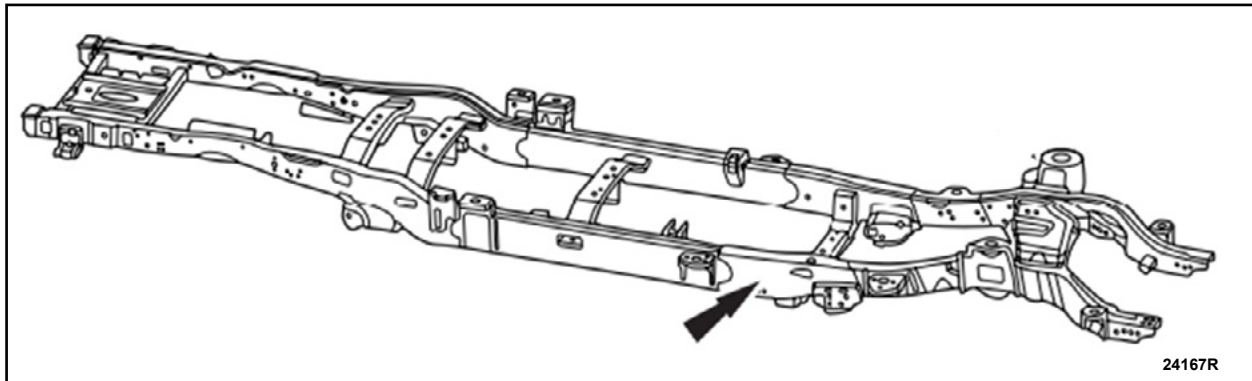

**FIGURE 7**

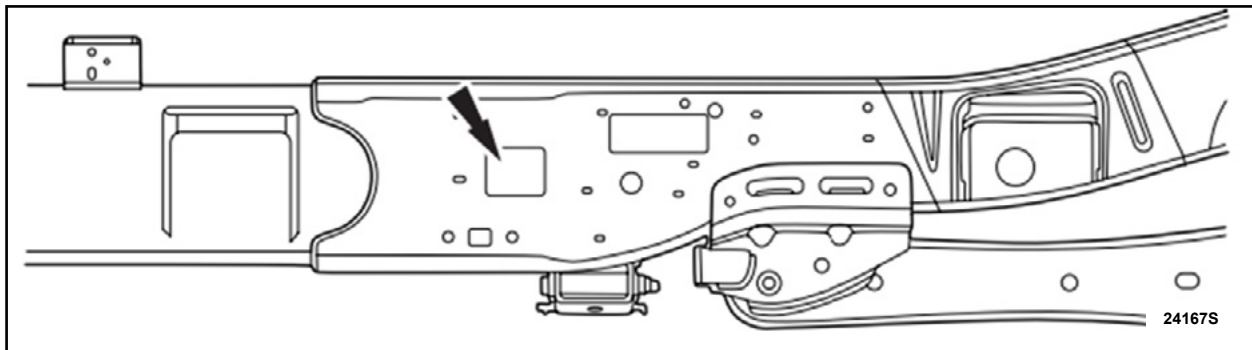

**FIGURE 8**



2. Locate the part number prefix and suffix on the part number label. Cross-reference the prefix and suffix in the Parts Requirement/Ordering Information section in the dealer bulletin to determine the required frame assembly service part number. See Figure 9.

- (1) Prefix.
- (2) Suffix.



FIGURE 9

**NOTE:** Vehicle wheelbase can be found:

- On the vehicle window sticker, which can be viewed from the OASIS pull down menu on PTS, or the window sticker link in HVBoM.
- On the Vehicle Certification Label.
- By clicking the Additional Information link on OASIS, and scrolling through the Build Information.

#### Historical Vehicle Bill Of Material (HVBoM) Method:

1. Click on HVBoM link in the PTS. See Figure 10.

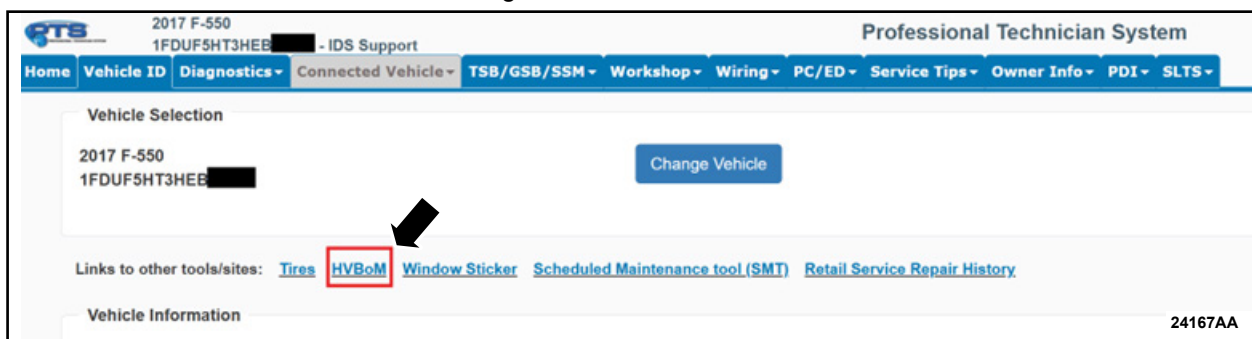

FIGURE 10



2. Type frame base part number 5005 in **Limit to Base** box. See Figure 11.

HVBoM - Historical Vehicle Bill of Material

Region : NA

Find Vehicle

Please select an area of the vehicle below, before proceeding. You may select a base part. If you have questions or comments, please email us by clicking on the link.

Powertrain  All  DSO

View BoM Print Reset

Limit to Base : 5005

24167AB

FIGURE 11

3. Use the engineering part number prefix and suffix and compare to the list under the **Parts Requirement/Ordering Information** in the dealer bulletin to determine the updated frame service part number. See Figure 12.

- (1) Prefix.
- (2) Suffix.

HVBoM - Historical Vehicle Bill of Material

Language : English

Region : NA

VIN : 1FD0X5HT5KEE

Find Vehicle

2019 FORD F-550 SUPER CAB D

Categories : ALL - BASE PART NUMBER : 5005

Reset

PART	SERVICE PART	MTRCRAFT	QTY	DESCRIPTION
KC3C3005YA	JC3Z5005Q		1 FR	24167AC

FIGURE 12



**REPAIR SERVICE PROCEDURES**

**NOTE:** Refer to the up-fit manufacturer for the service procedures of the second unit body if it is not a sublet repair

**NOTE:** Refer to the Workshop Manual (WSM) and transfer components from the original frame to the *new* frame.

- A. 2017-2019 Vehicles - Replacement Frame ABS Bracket Removal..... Page 9
- B. DEF Pressure Line Re-route Procedures (choose the cab type and reductant tank configuration)
  - i. All Cabs Equipped with a LH Inboard Reductant Tank..... Page 10
  - ii. Regular Cab Vehicles with RH Outboard Reductant Tank.....Page 12
  - iii. Super Cab and Crew Cab Vehicles with RH Outboard Reductant Tank.....Page 15
- C. Wire Harness Crush Shield Installation..... Page 17
- D. Wire Harness to Flag Stud Interference Correction.....Page 18
- E. Wire Harness Shield Contacting Fuel Tank Strap Correction..... Page 19
- F. Exhaust Hanger Modification..... Page 23



### A. 2017-2019 vehicles - Replacement Frame ABS Bracket Removal

**⚠ WARNING: Use proper eye, face, and ear protection. Failure to follow this instruction may result in serious personal injury or death.**

1. Using an angle grinder, grind the 3 welds between the ABS bracket and the LH shock tower as shown in Figures 13 and 14.

- a. Remove and discard the ABS bracket.
- b. Finish the metal and grind the welds flat.
- c. Restore corrosion protection to areas that have been ground.
  - i. Ensure that the surface is clean and dry, and above 35 degrees F.
  - ii. Dress welds as required.
  - iii. Thoroughly clean and degrease metal surfaces using Motorcraft® Metal Surface Prep ZC-31-A.
  - iiii. Apply a coating of Daubert NOXRUST X-121B to the repair area per the manufacturer's direction.

- (1) Remove weld.
- (2) Bracket.

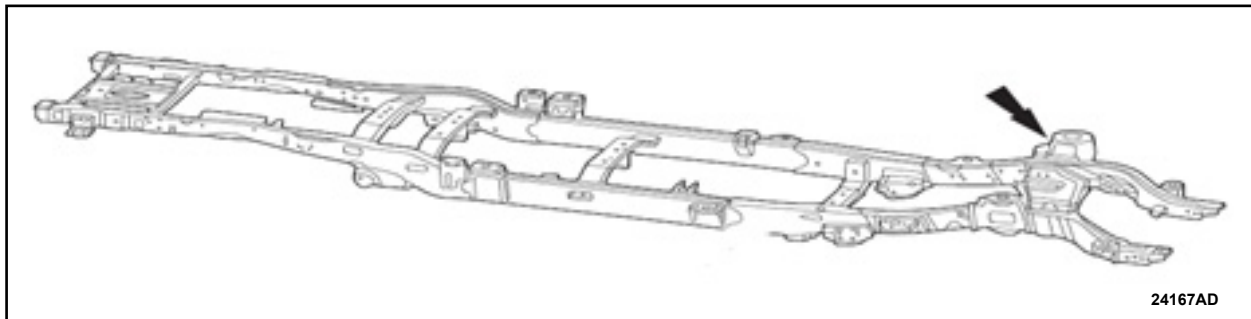

**FIGURE 13**

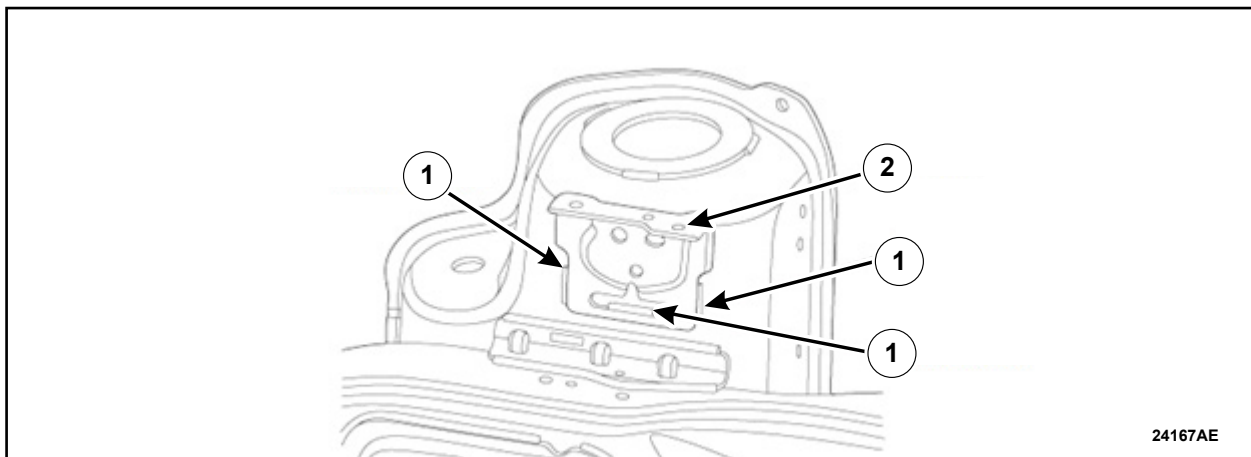

**FIGURE 14**



## **B. Diesel Exhaust Fluid (DEF) Pressure Line Re-route**

### **For Vehicles Equipped With Left Hand Side Inboard Mounted Reductant Tank**

1. Detach the two (2) DEF pressure line retainers that retain the line to the frame, under the number 4 crossmember as shown in Figure 15. Position the DEF pressure line aside.

**NOTE:** The DEF pressure line is shown in the factory installed position.

- (1) Front of Vehicle.
- (2) Number 4 crossmember.
- (3) Left hand frame rail.
- (4) Detach the Def retainers from the frame.

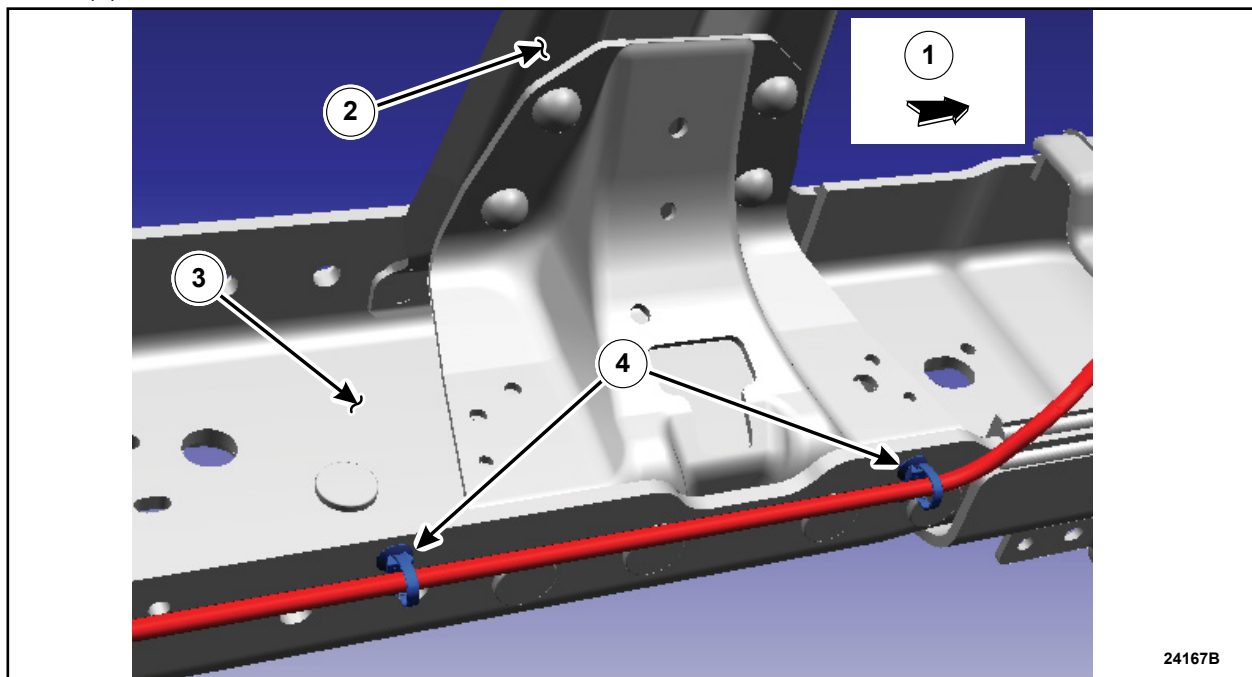
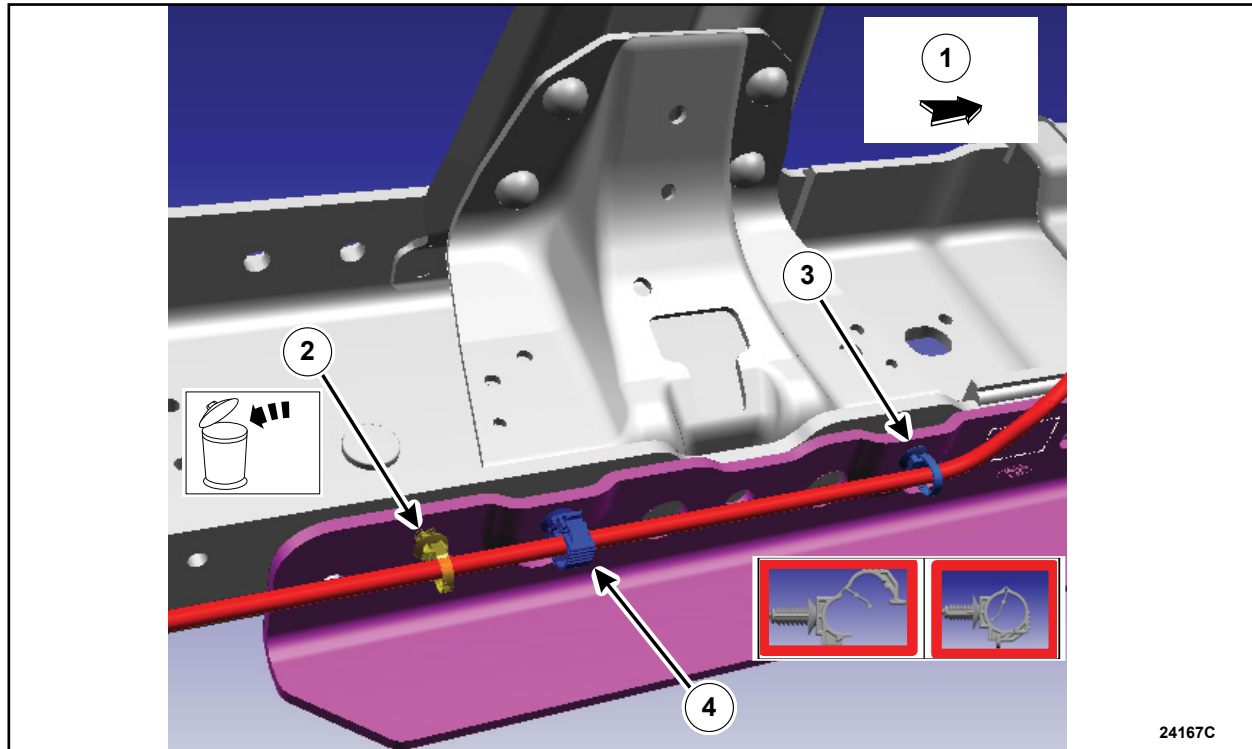

**FIGURE 15**



2. Once the LH side lower bracket has been installed, position back the DEF pressure line and attach the existing front line to frame retainer to the lower bracket. Then, remove and discard the original rear line to frame retainer from the DEF pressure line. Then, attach the supplied clasp retainer to the DEF pressure line and install into the rear lower bracket retainer hole as shown in Figure 16.

- (1) Front of Vehicle.
- (2) Fully remove the rear retainer from the DEF pressure line.
- (3) Reuse and install the original front DEF pressure line retainer to the lower bracket.
- (4) Attach and install the rear DEF pressure retainer.



**FIGURE 16**

3. Proceed to the next required Repair Service Procedure.



## **B. Diesel Exhaust Fluid (DEF) Pressure Line Re-route**

### **For All Regular Cab Vehicles Equipped With Right Hand Side Outboard Mounted Reductant Tank**

1. Detach the single DEF pressure line retainer from the RH lower frame as shown in Figure 17. Then, completely remove and discard the retainer from the DEF pressure line.

- (1) Front of Vehicle.
- (2) DEF pressure line retainer to frame location.
- (3) Reductant tank.
- (4) Do not disconnect or remove this retainer.
- (5) DEF pressure line.

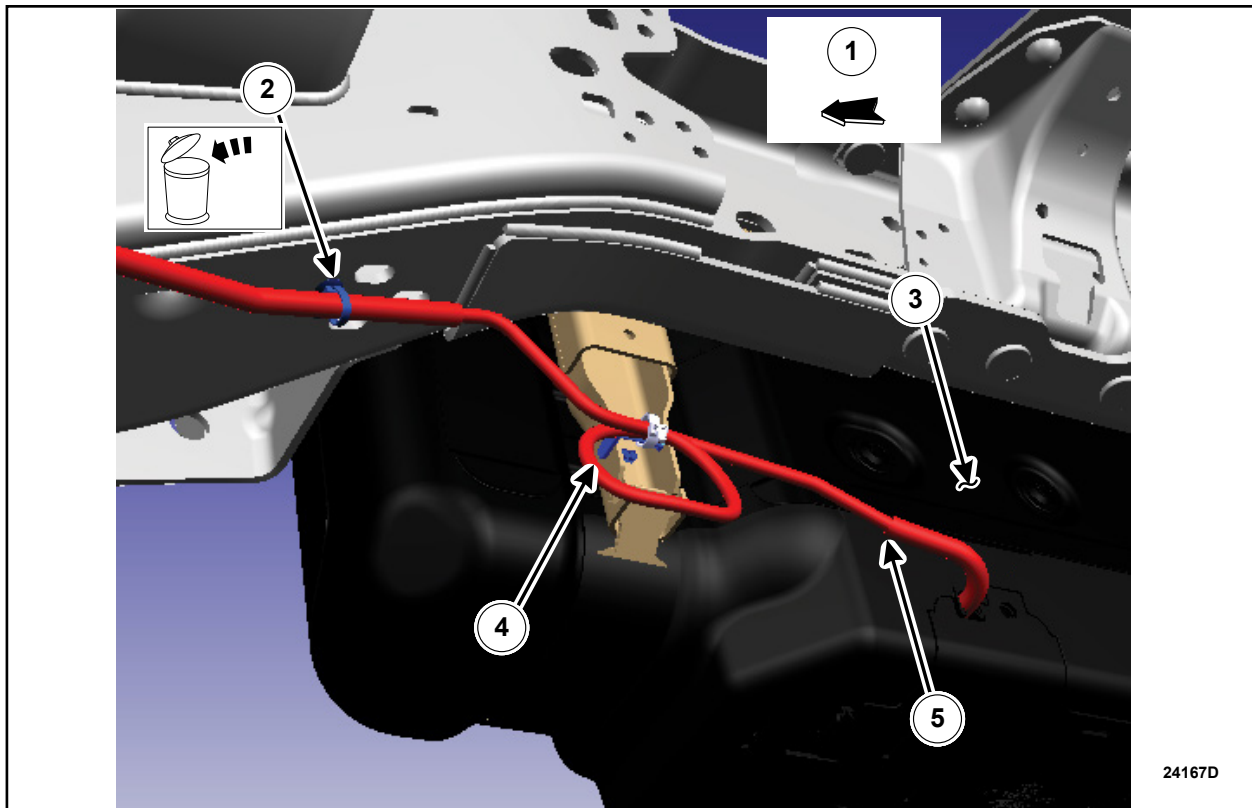

**FIGURE 17**



2. Once the RH side lower bracket has been installed, install the supplied T clip to the lower bracket and route the DEF pressure line toward the T clip and attach the T clip to the DEF pressure line with two (2) of the supplied zip ties as shown in Figure 18.

**NOTE:** Figure 18 shows the different T clip locations for between the regular cab vehicles and Crew and Super Cab vehicles. Holes are pre drilled on bracket for T clip, will need to drill new hole for routing clip.

- (1) Front of Vehicle.
- (2) Original DEF pressure line routing.
- (3) Regular cab T clip location.
- (4) Crew and super cab T clip location.
- (5) New DEF pressure line routing.
- (6) Attach the T clip to the line using zip ties.
- (7) Reductant tank.

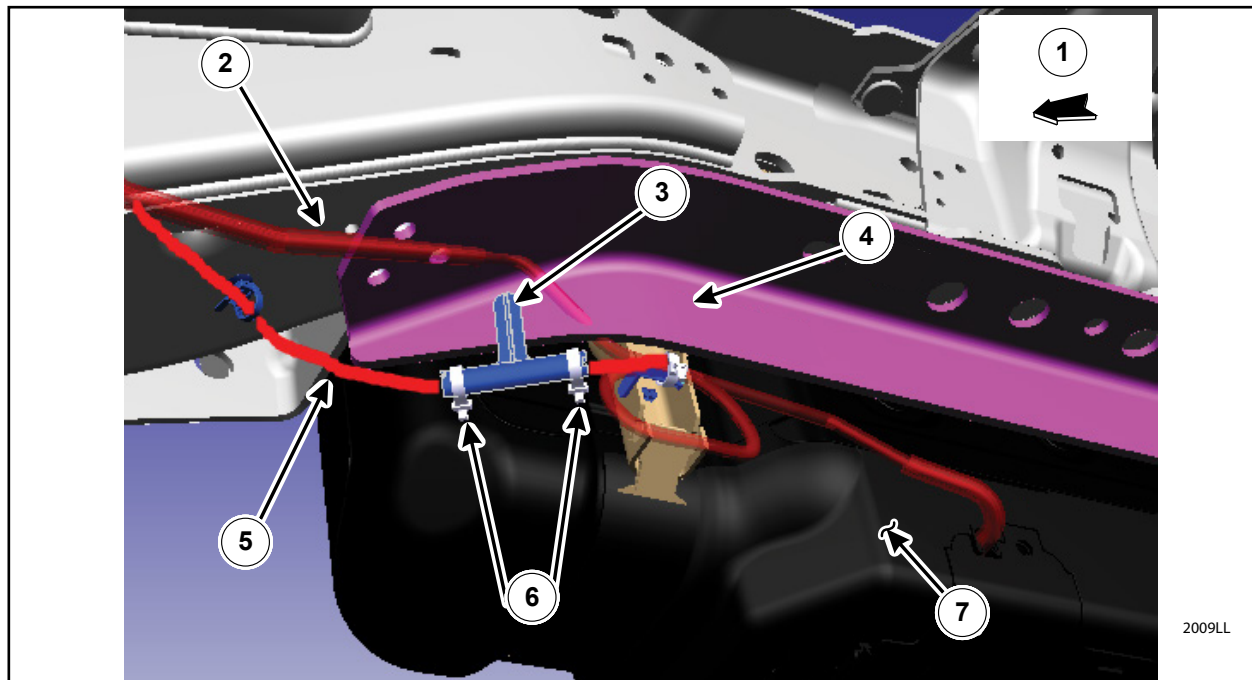

FIGURE 18



3. Using a drill and an 8mm (0.31 in) bit, drill a *new* hole location, for the *new* routing clip, forward of the lower frame rail bracket. Using a small brush and Motorcraft® High Temperature Anti-Corrosion Coating (PM-13-A), apply the coating in and around the hole that was just drilled, to cover any bare metal present from the drilling of the hole. Then, install the supplied push pin zip tie into the new hole location and position the DEF pressure line and secure in place with the zip tie as shown in Figure 17.

**NOTE:** The *new* drill hole location should be determined by positioning the DEF pressure line in its natural relaxed position toward the frame and marking a location for the *new* drill hole, forward of the *new* reinforcement bracket as shown in Figure 19.

- (1) Front of Vehicle.
- (2) Relocate retainer hole in this location.
- (3) Original DEF pressure line retainer hole.
- (4) New DEF pressure line routing.
- (5) Reductant tank.

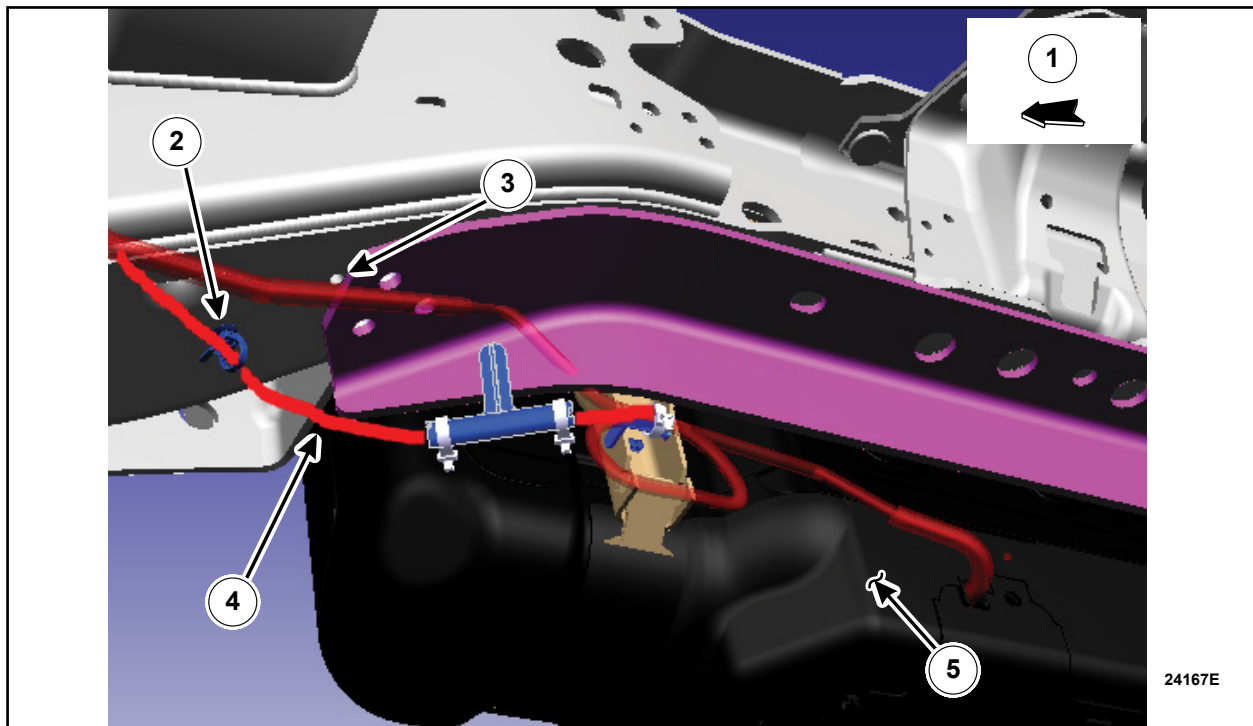

**FIGURE 19**

4. Proceed to the next required Repair Service Procedure.



## **B. Diesel Exhaust Fluid (DEF) Pressure Line Re-route**

**For All Super Cab And Crew Cab Vehicles With RH Side Outboard Mounted Reductant Tanks**

1. Remove and discard the clip and zip tie from the area shown in Figure 20.

- (1) Front of Vehicle.
- (2) Right hand frame rail.
- (3) DEF pressure line.
- (4) Remove and discard the clip and zip tie.
- (5) Reductant tank.

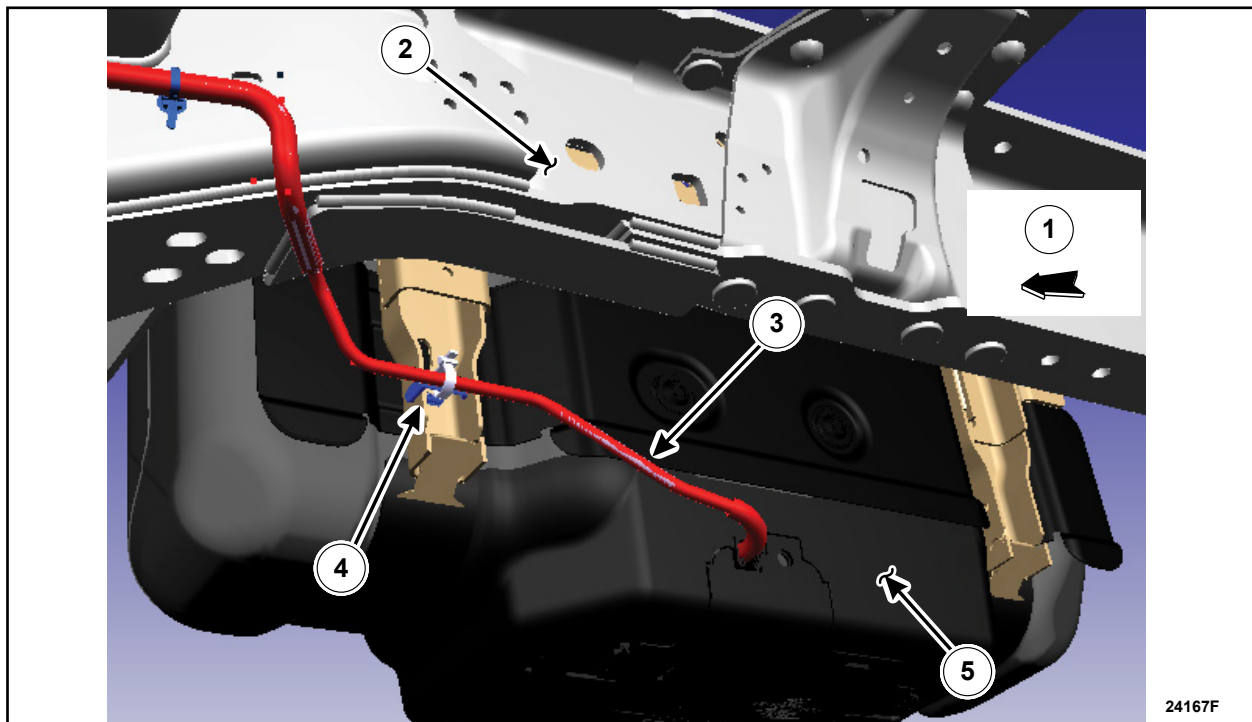
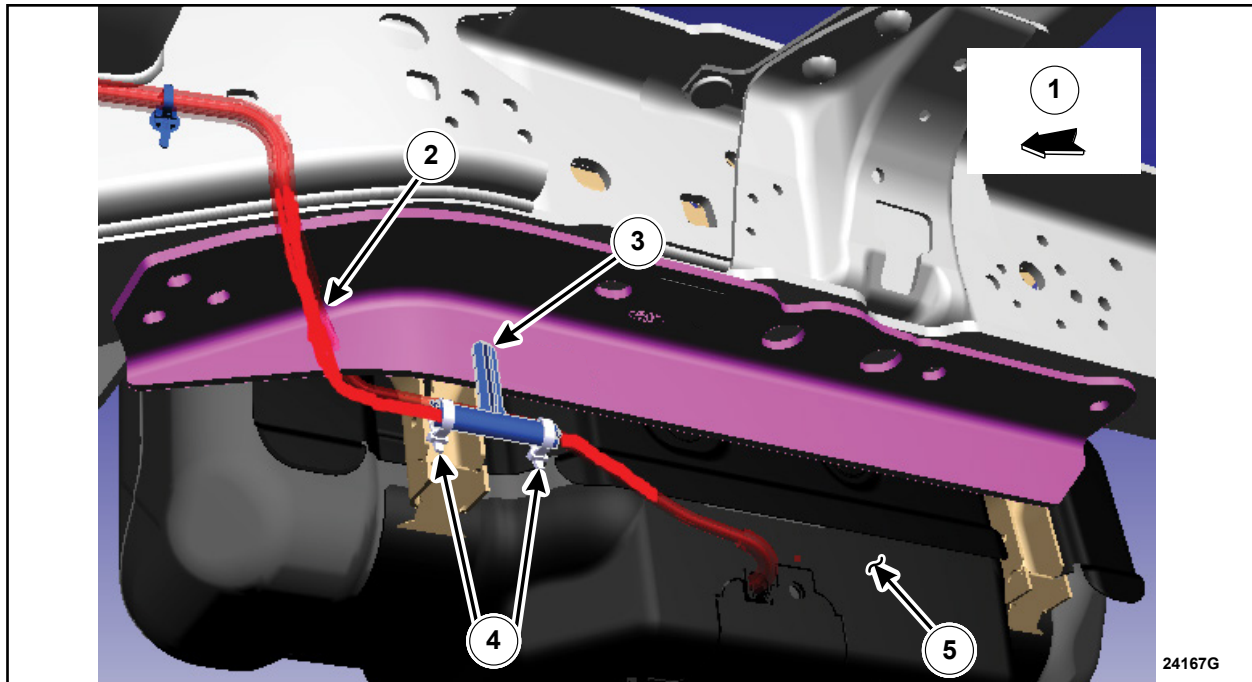

**FIGURE 20**



2. Once the RH side lower bracket has been installed, install the supplied T clip to the existing hole in the lower reinforcement bracket and route the DEF pressure line toward the T clip and attach the T clip to the DEF pressure line with two (2) of the supplied zip ties as shown in Figure 21.

- (1) Front of Vehicle.
- (2) New DEF pressure line routing.
- (3) T clip location.
- (4) Attach the T clip to the line using zip ties.
- (5) Reductant tank.



**FIGURE 21**

3. Proceed to the next required Repair Service Procedure.



### **C. Wire Harness Crush Shield Installation - Lower Bracket**

**For All Vehicles Equipped With Gas Fuel Tank and Diesel Mid Ship Fuel Tank and One Of The Following Wheel Bases**

- 145" Wheelbase Vehicles - Regular Cab
- 168" Wheelbase Vehicles - Super Cab
- 179" Wheelbase Vehicles - Crew Cab

1. Install a crush shield on the left hand side frame rail harness as follows;

- Remove the tie strap push pin (a) from the hole indicated in Figure 22.
- Mark the location of the push pin on the harness (b).
- Cut off the existing push pin from the harness removed in sub-step a.
- Install the provided crush shield (d) on the harness with the rear edge of the shield aligning the mark made in second bullet point (above). See Figure 22.
- Secure both ends of the crush shield with the supplied Coroplast Tape (e).
- Install the supplied push pin zip tie in same location as the previously marked (original) location on the harness (b).

- (1) Secure both ends with anti-abrasion tape.  
(2) 100 mm long crush shield.

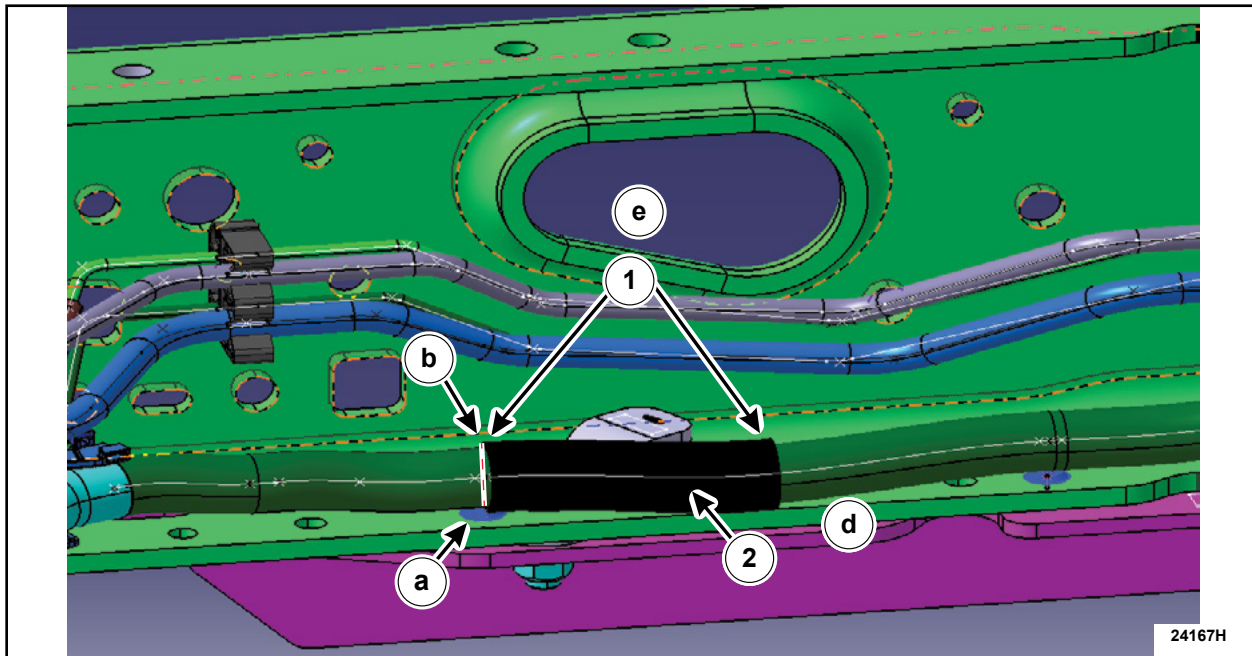

**FIGURE 22**

2. Proceed to the next required Repair Service Procedure.



### D. Wire Harness Shield To Flag Stud Interference Correction

For Vehicles Equipped With Left Hand Side Inboard Mounted Reductant Tank and One Of The Following Wheel Bases

- 145" Wheelbase Vehicles - Regular Cab
- 168" Wheelbase Vehicles - Super Cab
- 179" Wheelbase Vehicles - Crew Cab

1. For the left hand side lower frame rail bracket, the rear flag stud will contact the harness shield if not raised. Raise the harness by completing the follow steps;

- a. Position the supplied stud clips onto the studs with the zip ties side facing inboard as shown in Figure 23.
- b. Secure the harness to the stud clips with the zip ties.
- c. Ensure that the harness shield is positioned above the flag stud and the stud clips are fully seated on the studs.

- (1) Front of Vehicle.
- (2) Left hand side frame rail transparent view.
- (3) Stud clip locations and inboard direction.
- (4) Wire harness shield.
- (5) Lower bracket rear flag stud.

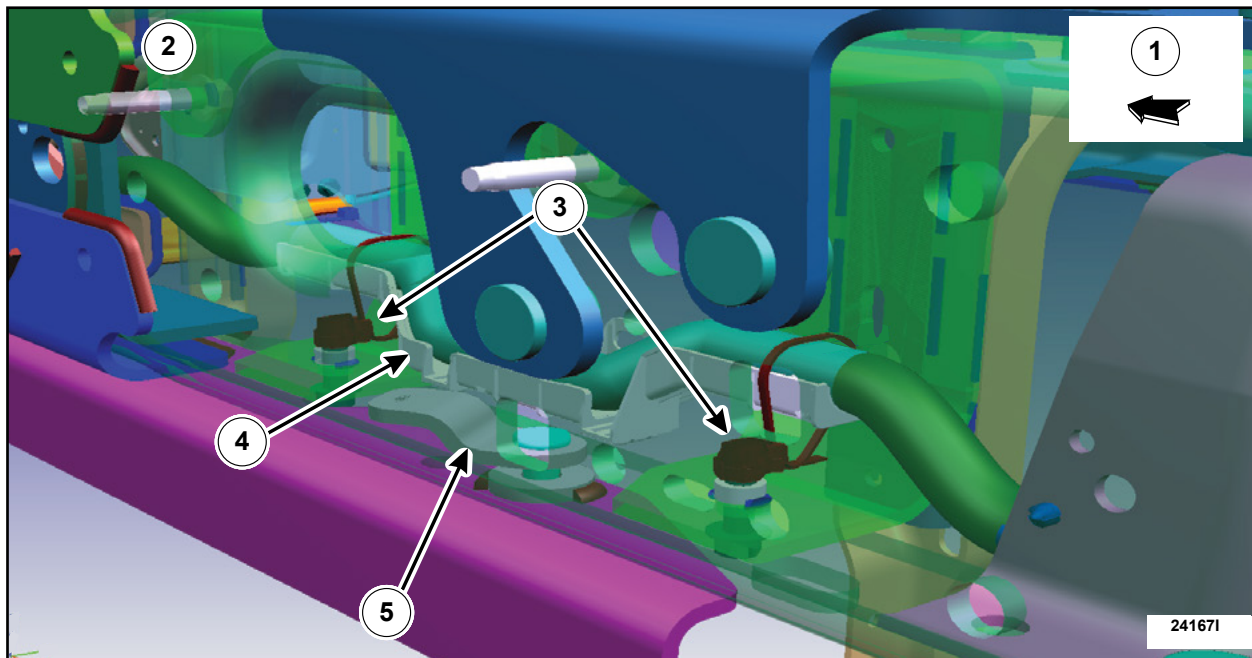

**FIGURE 23**

2. Proceed to the next required Repair Service Procedure.



### **E. Wire Harness Shield Contacting Fuel Tank Strap Correction**

#### **For Vehicles Equipped With Mid-Ship Fuel Tank**

1. From the left hand side lower frame rail, remove the harness shield push pins as shown in Figure 24.

- (1) Harness shield push pins.
- (2) Wiring harness shield.
- (3) Mid ship fuel tank strap.

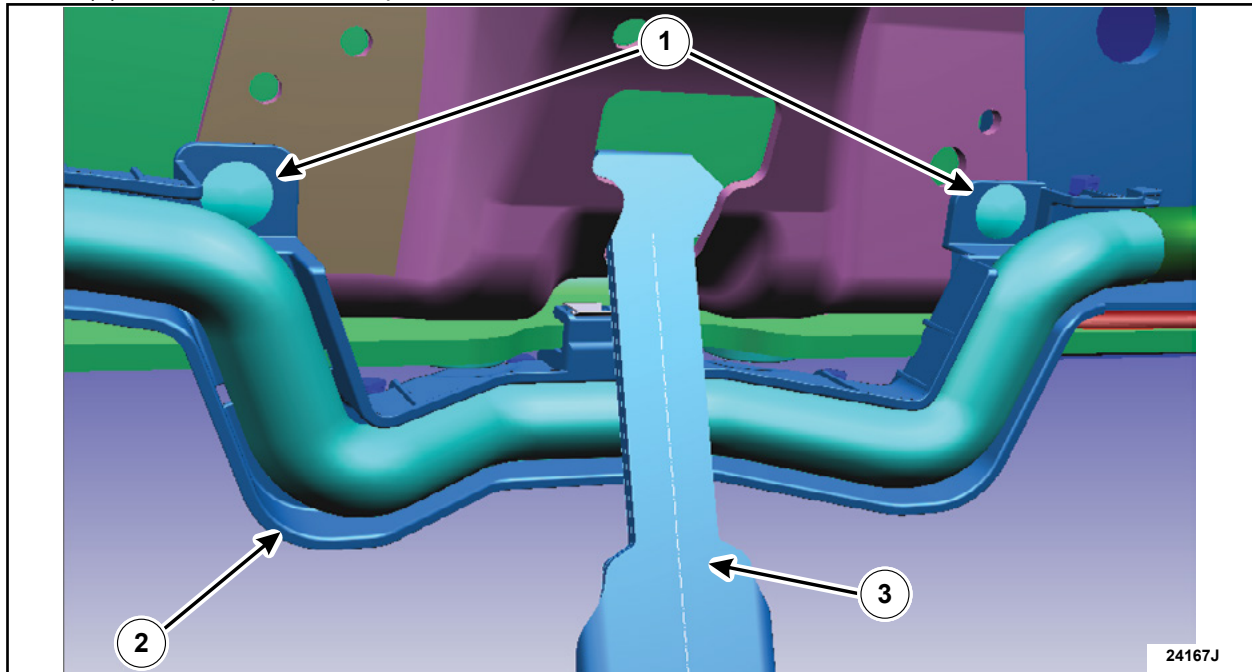
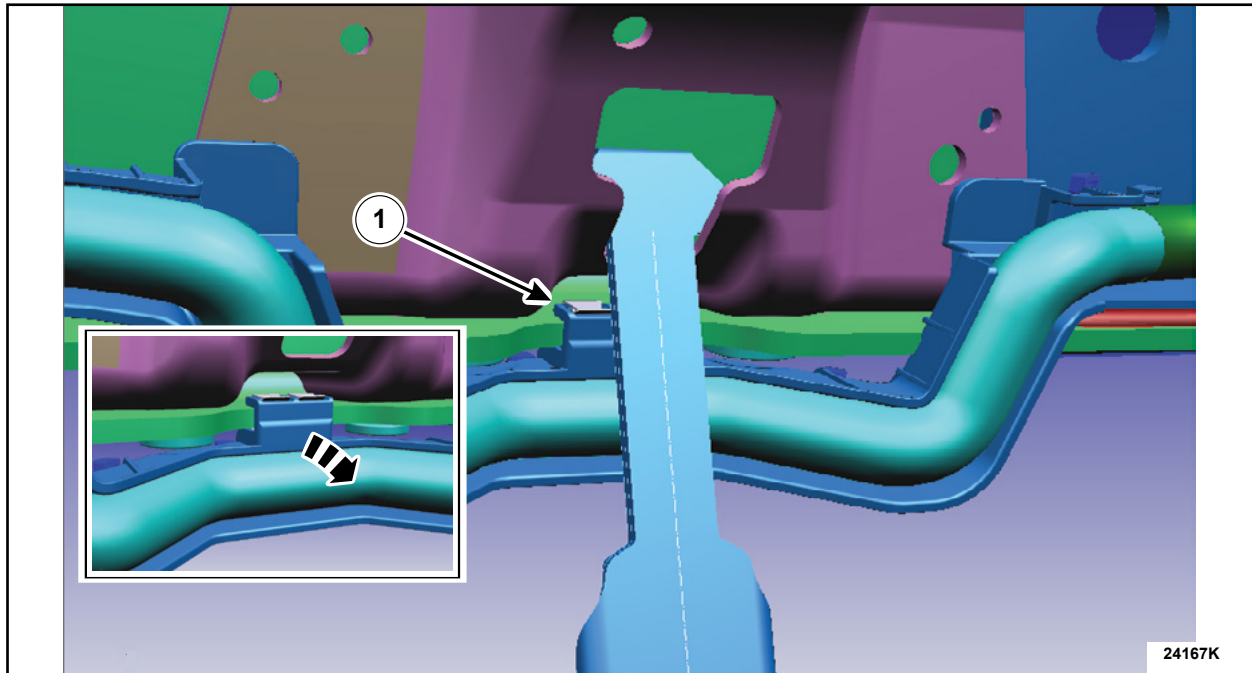

**FIGURE 24**



2. Detach the edge biter clip from the frames lower flange as shown in Figure 25.

(1) Edge biter.



**FIGURE 25**

3. Remove the seven (7) tie straps holding the harness to the harness shield.

4. Using a suitable cutting tool, remove the edge biter clip flush with the surface of the harness shield as shown in Figure 26.

(1) Remove the edge biter.

(2) Edge biter removed.

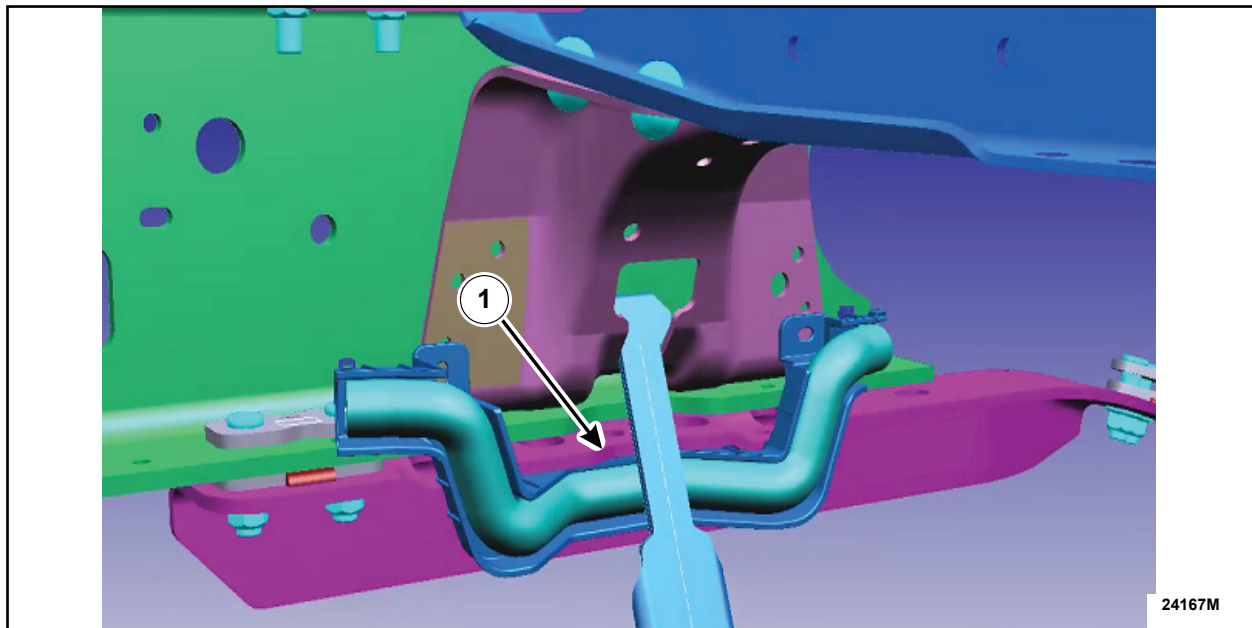

**FIGURE 26**



5. Reattach the shield to the harness, in the same locations as they were removed from in Step 3, using seven (7) of the similar supplied tie straps.
6. Once the frame rail bracket has been installed, position the middle of the harness shield under the frame rail bracket as shown in Figure 27. Then, using two (2) of the supplied tie straps, secure the harness shield in the same location as the push pins were removed from in Step 1.

(1) Position the shield under the frame rail bracket.



**FIGURE 27**



7. Using two (2) of the larger supplied tie straps, secure the harness shield to the reinforcement bracket using the existing holes in the reinforcement bracket.

8. Ensure that the wiring harness shield has at least 9.5mm (0.37 in.) of clearance from any contact to the mid ship fuel tank. See Figure 28.

- (1) Mid ship fuel tank.
- (2) 9.5 mm (0.37 in).
- (3) Harness shield.

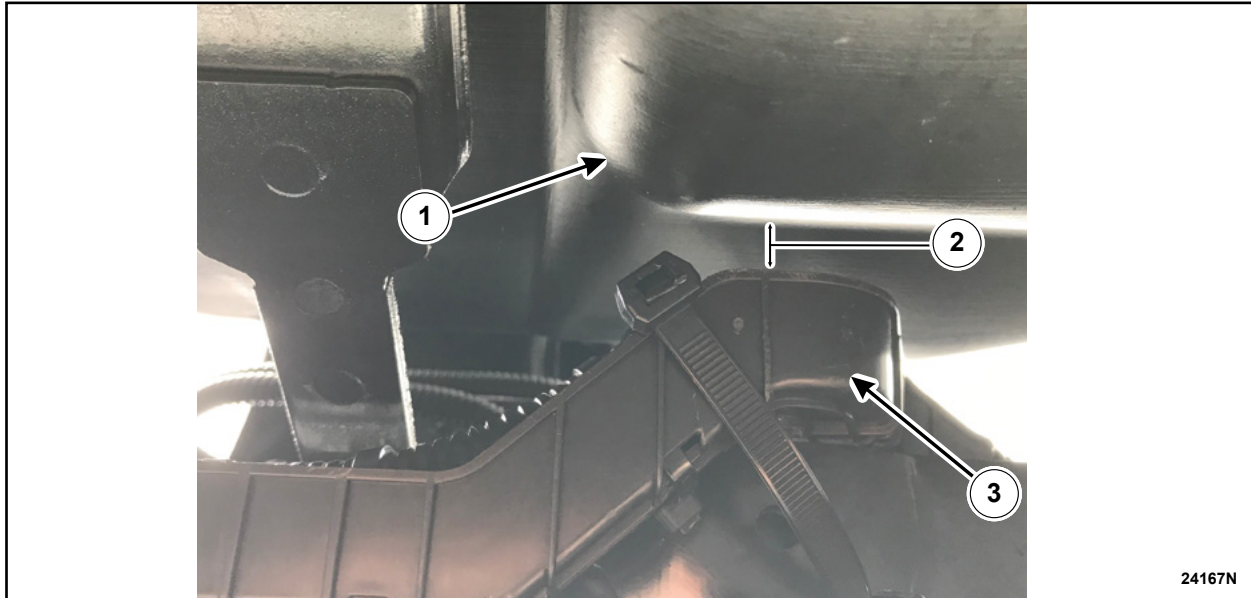

**FIGURE 28**

9. Proceed to the next required Repair Service Procedure.



## **F. Exhaust Hanger Modification Procedure**

### **For Right Hand Side Lower Frame Rail Installation**

#### **Diesel Vehicles Only:**

1. The right hand side exhaust hanger will interfere with right hand side lower reinforcement bracket.  
Figure 29 shows the portion of the exhaust hanger that will be removed in order to obtain the clearance needed.

- (1) Front of Vehicle.
- (2) The portion of exhaust hanger to be removed in yellow.

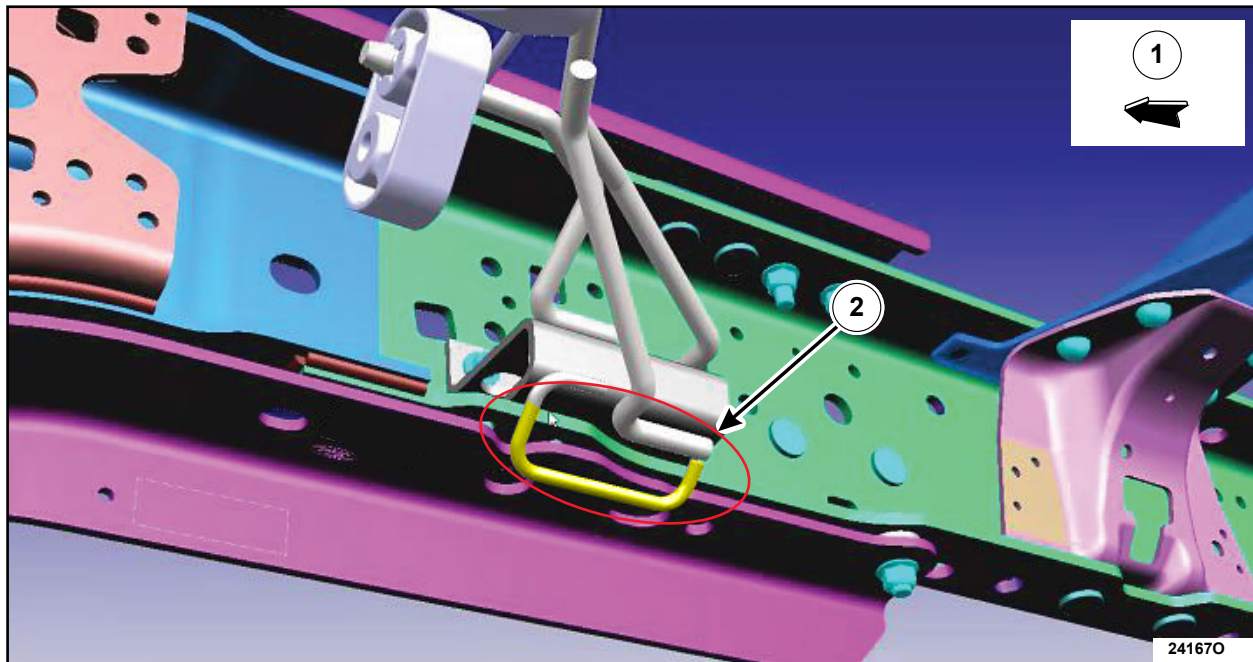
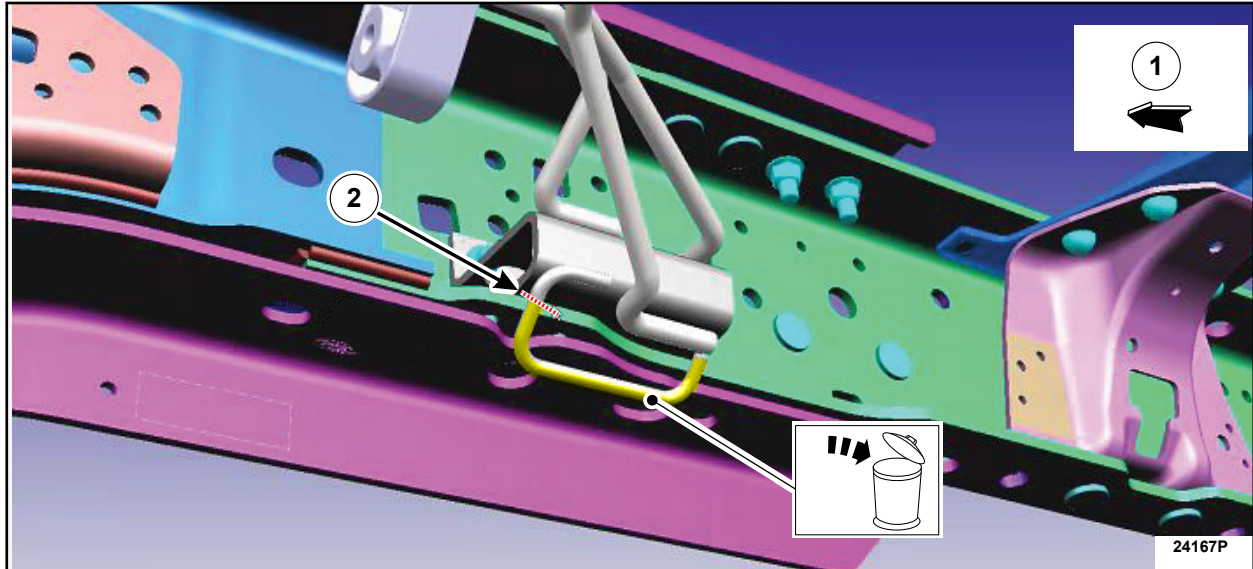

**FIGURE 29**



2. Using a suitable cutting tool, cut the exhaust hanger in the location shown in Figure 30. Remove and discard the cut off portion of exhaust hanger. See Figure 30.

- (1) Front of Vehicle.
- (2) Cut and remove the portion of exhaust hanger here.



**FIGURE 30**

3. Figure 31 shows the final result once the exhaust hanger portion is removed.

- (1) Front of Vehicle.
- (2) Final result.

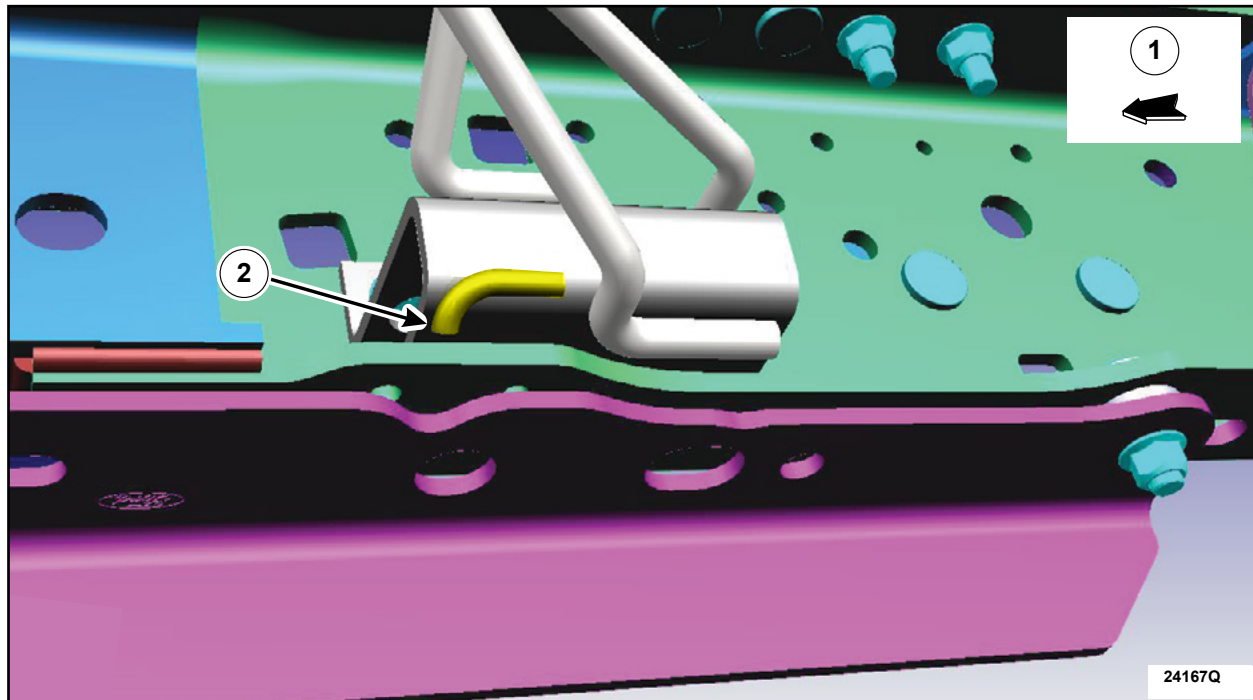

**FIGURE 31**



**IMPORTANT NOTE:** Federal law prohibits selling motor vehicle parts or components that are under safety, compliance, or emissions recall. Unless a part is requested to be returned to Ford, all parts replaced under this FSA must be scrapped in accordance with all applicable local, state and federal environmental protection and hazardous material regulations. Refer to the Parts Retention, Return, & Scrapping section of the FSA dealer bulletin for further information.

