

<b>Subject:</b>  REAR BUMPER DISTORTED	Service Alert No.: SA-008/26
	Last Issued : 02/20/2026

## BULLETIN NOTES

This SA supersedes the previously issued SA(s) listed below. The changes are noted in Red.

Previous SA:	Date(s) Issued:
SA-041/25	10/31/25 and 09/10/25
SA-035/22	05/20/22

## APPLICABLE MODEL(S)

2023-2026 CX-50 (All)

## DESCRIPTION

During PDI, an indentation in the rear bumper may be noticed, or in some cases, the customer may return after delivery to report the indentation. Follow the steps below to repair the concern.

## REPAIR PROCEDURE

**NOTE:** For improved clarity, click on any image in the procedure below to view it at full size.

1. Check the rear bumper for an indentation.

Is the indentation in the same location (red dot) on the bumper as in the examples shown below?

- **YES** - Continue to the next step.
- **NO** - This Service Alert does not apply; please contact the Mazda Technical Hotline for assistance.



**CONSUMER NOTICE:** The information and instructions in this bulletin are intended for use by skilled technicians. Mazda technicians utilize the proper tools/ equipment and take training to correctly and safely maintain Mazda vehicles. These instructions should not be performed by "do-it-yourselfers." Customers should not assume this bulletin applies to their vehicle or that their vehicle will develop the described concern. To determine if the information applies, customers should contact their nearest authorized Mazda dealership. Mazda North American Operations reserves the right to alter the specifications and contents of this bulletin without obligation or advance notice. All rights reserved. No part of this bulletin may be reproduced in any form or by any means, electronic or mechanical--including photocopying and recording and the use of any kind of information storage and retrieval system ---without permission in writing.

## 2. Prepare the tape by cutting and assembling into a foam block.

a. Cut the 10 ft roll into the following pieces (all pieces are full width of the tape – 1-1/4 inch / ~32 mm):

- 3 pieces at 30 mm length each
- 2 pieces at 40 mm length each

b. Assemble these into a single block/pad as shown in the diagram below (stack/align layers to create the overall ~120 mm × ~36 mm × 9 mm pad with 40 mm side extensions).

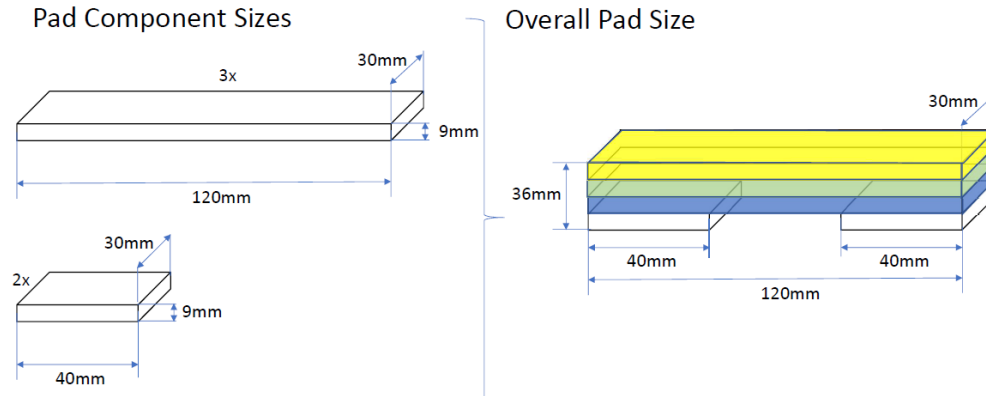

**Expected yield:** One 10 ft roll provides material for **at least 15 vehicles** (conservative estimate accounting for typical technician cutting inaccuracies, minor waste, and imperfect cuts). The maximum possible is **17 vehicles** if cuts are very efficient and minimal waste. Plan accordingly for shop volume.

4. Remove the rear bumper according to the instructions on MGSS (REAR BUMPER REMOVAL/INSTALLATION).
5. Place the bumper face down on a clean soft surface (such as a fender cover).



**CONSUMER NOTICE:** The information and instructions in this bulletin are intended for use by skilled technicians. Mazda technicians utilize the proper tools/ equipment and take training to correctly and safely maintain Mazda vehicles. These instructions should not be performed by "do-it-yourselfers." Customers should not assume this bulletin applies to their vehicle or that their vehicle will develop the described concern. To determine if the information applies, customers should contact their nearest authorized Mazda dealership. Mazda North American Operations reserves the right to alter the specifications and contents of this bulletin without obligation or advance notice. All rights reserved. No part of this bulletin may be reproduced in any form or by any means, electronic or mechanical--including photocopying and recording and the use of any kind of information storage and retrieval system ---without permission in writing.

6. Locate this raised rectangle (The area highlighted by the red dashed line in the image below) at the center of the back of the bumper.

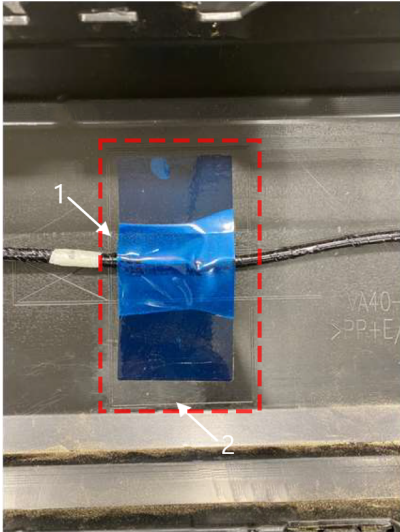

- If it has backup sensors, remove the tape in this location holding the harness to the bumper.

7. Clean the surface within the rectangle using isopropyl alcohol.

8. With the bumper in the orientation shown in step 5, remove the tape backing from the foam block created, align it to the left (1) and bottom (2) edges of the raised rectangular area on the inner side of the bumper and press the block firmly into place. **NOTE:** If it has backup sensors, do not forget to put the harness into the gap built into the block you created.

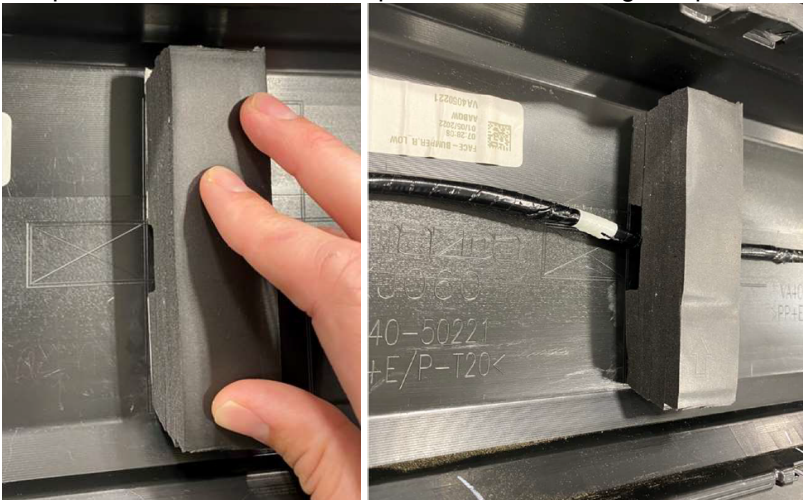

- If the indent is still visible, take photos of the bumper indentation and upload them to the Hotline file, then call Hotline to request approval for a replacement bumper.

9. Reinstall the rear bumper according to the instructions on MGSS (REAR BUMPER REMOVAL/INSTALLATION).

**CONSUMER NOTICE:** The information and instructions in this bulletin are intended for use by skilled technicians. Mazda technicians utilize the proper tools/ equipment and take training to correctly and safely maintain Mazda vehicles. These instructions should not be performed by "do-it-yourselfers." Customers should not assume this bulletin applies to their vehicle or that their vehicle will develop the described concern. To determine if the information applies, customers should contact their nearest authorized Mazda dealership. Mazda North American Operations reserves the right to alter the specifications and contents of this bulletin without obligation or advance notice. All rights reserved. No part of this bulletin may be reproduced in any form or by any means, electronic or mechanical---including photocopying and recording and the use of any kind of information storage and retrieval system ---without permission in writing.

**PARTS INFORMATION**

**Parts Department: Order/Purchase these items locally:**

a. M-D Building Products model 43154 – Black Sponge Window Seal (EX-LARGE size), closed-cell PVC sponge tape, self-adhesive, dimensions: 3/8 inch thick × 1-1/4 inch wide × 10 feet long (black color, single 10 ft roll per package).

**NOTE:** One 10 ft roll provides material for **at least 15 vehicles** (conservative estimate accounting for typical technician cutting inaccuracies, minor waste, and imperfect cuts). The maximum possible is **17 vehicles** if cuts are very efficient and minimal waste. Plan accordingly for shop volume.

- Available at Home Depot, Lowe's, Ace Hardware, or similar local suppliers.
- Search by: "M-D 43154" or "1.25 in. x 10 ft. Black Sponge Window Seal for Ex-Large Gaps" or "M-D Building Products 43154 sponge weatherstrip".
- UPC: 043374431544. One roll is required per vehicle repair (see Step 3 for preparation).

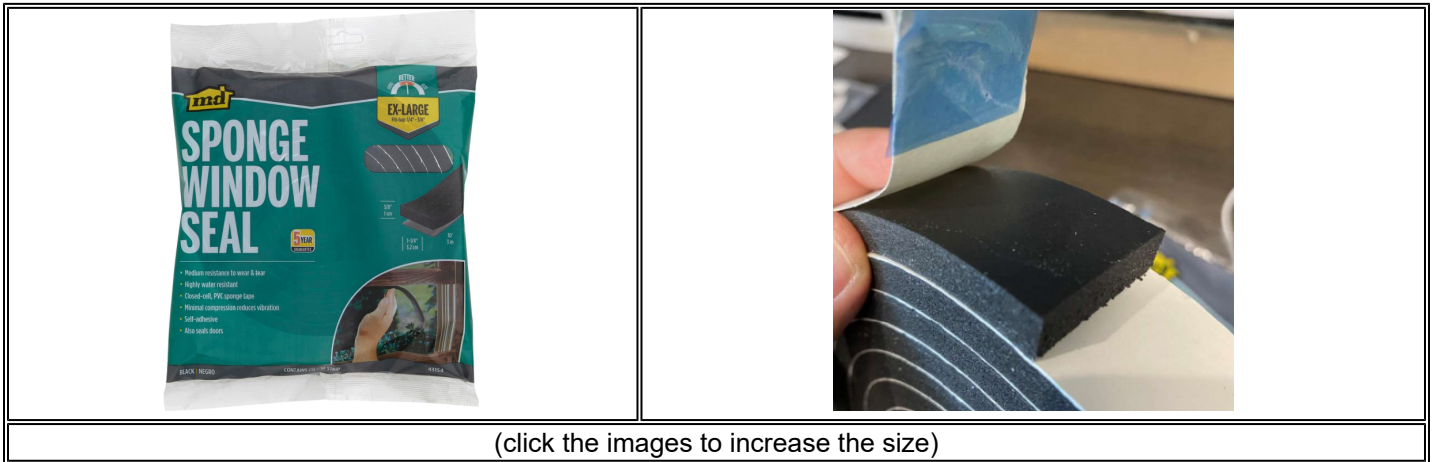

b. Isopropyl (rubbing) alcohol (locally sourced).



Parts Number	Description	Qty.	Notes
VA40-50-221A	Bumper, Rear	1	without backup sensors
VA43-50-221A	Bumper, Rear	1	with backup sensors

**CONSUMER NOTICE:** The information and instructions in this bulletin are intended for use by skilled technicians. Mazda technicians utilize the proper tools/ equipment and take training to correctly and safely maintain Mazda vehicles. These instructions should not be performed by "do-it-yourselfers." Customers should not assume this bulletin applies to their vehicle or that their vehicle will develop the described concern. To determine if the information applies, customers should contact their nearest authorized Mazda dealership. Mazda North American Operations reserves the right to alter the specifications and contents of this bulletin without obligation or advance notice. All rights reserved. No part of this bulletin may be reproduced in any form or by any means, electronic or mechanical---including photocopying and recording and the use of any kind of information storage and retrieval system ---without permission in writing.

**WARRANTY INFORMATION**

Warranty Type	A
Symptom Code	87
Damage Code	9B
Part Number Main Cause	VA40-50-221A
Quantity	0 or 1
Operation Number / Labor Hours:	S0206XRT / 2.2 hrs (with backup sensors) S0206XRT / 2.1 hrs (without backup sensors)

**CONSUMER NOTICE:** The information and instructions in this bulletin are intended for use by skilled technicians. Mazda technicians utilize the proper tools/ equipment and take training to correctly and safely maintain Mazda vehicles. These instructions should not be performed by "do-it-yourselfers." Customers should not assume this bulletin applies to their vehicle or that their vehicle will develop the described concern. To determine if the information applies, customers should contact their nearest authorized Mazda dealership. Mazda North American Operations reserves the right to alter the specifications and contents of this bulletin without obligation or advance notice. All rights reserved. No part of this bulletin may be reproduced in any form or by any means, electronic or mechanical---including photocopying and recording and the use of any kind of information storage and retrieval system ---without permission in writing.