



Countries: AUSTRALIA, BAHAMAS, BOLIVIA, BRAZIL, BELIZE, CANADA, CHILE, TAIWAN, COLOMBIA, COSTA RICA, DOMINICAN REPUBLIC, ECUADOR, EL SALVADOR, GUAM, GUATEMALA, GUYANA, HAITI, HONDURAS, JAMAICA, KOREA, SOUTH KOREA, MEXICO, ARUBA, NEW ZEALAND, NICARAGUA, PANAMA, PERU, PUERTO RICO, RUSSIA, SOUTH AFRICA, TRINIDAD AND TOBAGO, UNITED STATES, URUGUAY, VENEZUELA, Curaçao

Document ID: IK2600300

Availability: ISIS, FleetSIS, NotSIR

Major System: PROGRAMMING SUPPORT

Current Language: English

Other Languages: NONE

Viewed: 106

Revision: 2

Created: 1/6/2026

Last Modified: 2/27/2026

Author: Matthew Carrigan

[Less Info](#)

Hide Details

Coding Information

Copy Link 	Copy Relative Link 	Bookmark View My Bookmarks	Add to Favorites 	Print 	Provide Feedback 	Helpful 3	Not Helpful 0
----------------------	-------------------------------	--	-----------------------------	------------------	-----------------------------	-------------------------	-----------------------------

Title: N9/N10 & N13 Baud Rate Information Associated With Vehicle Programming

Applies To: N9/N10/N13 Engines and Body Control Modules

CHANGE LOG

Please refer to the change log text box below for recent changes to this article:

2/27/2026 - Adjusted formatting 01/29/2026 - Initial Article Release

DESCRIPTION

This article equips technicians with the knowledge and steps needed to efficiently replace and program N9/N10 and N13 modules, while addressing potential baud rate incompatibility issues between the replacement module and the vehicle.

SERVICE INFORMATION

Table Of Contents	
Introduction	The history of baud rate at International, and why it matters.
Identifying Vehicle Baud Rate	You MUST know the baud rate of the vehicle you are working on so you can obtain the correct module.
Use Correct Module	Certain modules can have their baud rate switched; others cannot. Use this information to obtain the correct module.
Determine Replacement Module Baud Rate	The baud rate of the module MUST match the baud rate of the vehicle.

[Switching Module Baud Rate](#)

This covers the programming processes that are needed in order to switch the baud rate of a module.

Introduction





It is possible to replace a module without encountering problems. However, you are likely here because you have encountered issues programming a replacement module (or a test module) for an N9/N10 or N13 engine. Before moving on to the programming processes that resolve these issues, it is important to understand what causes them - baud rate.

The term "baud rate" refers to speed of communication on the data link. Higher baud rate numbers refer to faster communication speeds. It is also important to understand that a 250k baud rate module will not work on a 500k vehicle - and vice versa. We need to start with some facts.

1. N9/N10 engines were built from 2014-2017.
2. N13 engines were built from 2013-2017.
3. International built vehicles with a 250k baud rate from 1994-2015.
4. International started building vehicles with 500k baud rate in August 2015 - right in the middle of N9/N10/N13 production.

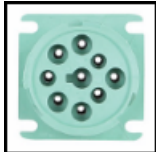
This means that early N9/N10/N13 engines use a 250k baud rate and late ones use 500k. **It is important to make sure we use replacement modules with the correct baud rate for the vehicle we are working on. A 250k ECM will not be detected on a 500k vehicle - and vice versa. Using a module with the wrong baud rate can result in a NavKal error 8 (N9/N10 & N13) or NavKal error 12 (N13).**

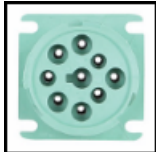
Identifying Vehicle Baud Rate

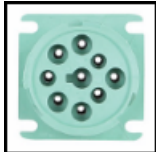
<p>9-pin connector color</p>	<table border="1" style="width: 100%; text-align: center;"> <tr> <td data-bbox="550 858 922 1026"> <p>Black = 250k</p> </td> <td colspan="2" data-bbox="922 858 1343 1026">  </td> </tr> <tr> <td data-bbox="550 1026 922 1197"> <p>Green = 500k</p> </td> <td colspan="2" data-bbox="922 1026 1343 1197">  </td> </tr> <tr> <td colspan="3" data-bbox="550 1197 1343 1312"> <p>Note: A green plug (on the end of a communication cable) can connect to both black and green receptacles. However, a black plug can only connect to black receptacles. For data link troubleshooting information, see IK0800080.</p> </td> </tr> </table>			<p>Black = 250k</p>			<p>Green = 500k</p>			<p>Note: A green plug (on the end of a communication cable) can connect to both black and green receptacles. However, a black plug can only connect to black receptacles. For data link troubleshooting information, see IK0800080.</p>		
<p>Black = 250k</p>												
<p>Green = 500k</p>												
<p>Note: A green plug (on the end of a communication cable) can connect to both black and green receptacles. However, a black plug can only connect to black receptacles. For data link troubleshooting information, see IK0800080.</p>												
<p>Year</p>	<p>1994~ Aug. 2015 = 250k</p> <p>~Aug. 2015-present = 500k</p>											
<p>Body controller type</p>	<p>Gen 1 is 250k 2001-2006</p>	<p>Gen 2 is 250k 2007-2015</p>	<p>Gen 4 BC can be used for 250k or 500k 2015-present</p>									

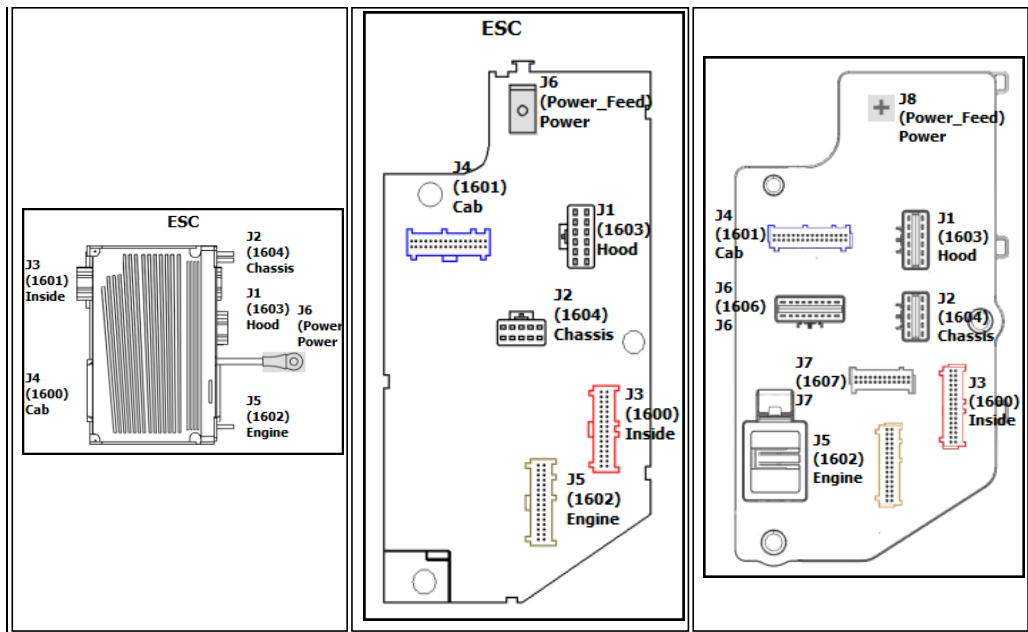

Calibration Name	N9/N10 ECM	Calibration 3rd character "T" = 250k (example: PBT5NPR2 or PMT6NPR2)
		Calibration 3rd character "U" = 500k (example: PMU5NPR2 or PBU7NPR2)
	N9/N10 ACM	Calibration 3rd character "T" = 250k (example: ANT5BCR1)
		Calibration 3rd character "U" = 500k (example: ANU5BCR1)
	N9/N10 DCU	Calibration 7th character "1" = 250k (example: RPRBBA10)
		Calibration 7th character "2" = 500k (example: RPRBBA20)
	N13 ECM	Calibration 2nd character "S" or "T" = 250k (example: OSQXKKMA or OTRXKKDA)
		Calibration 2nd character "Y" or "Z" = 500k (example: OYQXKKMB or OZPXKKAB)
	N13 ACM	Calibration 2nd character "S" = 250k (example OSANDXC)
		Calibration 2nd character "Y" = 500k (example OYANDXC)

[Return to Top](#)

Use Correct Module(s)				
(See IK2600273 for help visually identifying these modules)				
Engine	Module	Parts Information	Can Module Baud Rate Be Changed?	Who Can Change Baud Rate?
N9/N10 250k	ECM	7095136c91 should show SID 914 on label (see TR2600003 for SID information)	Yes	Dealer
	ACM	3988097c2	Yes	Tech Services (Dealer cannot)
	DCU	7094050c1	No	No One
N9/N10 500k	ECM	7095136c91 should show SID 914 on label (see TR2600003 for SID information)	Yes	Dealer
	ACM	4063287c1	Yes	Tech Services

N13			
ECM (baud rate determined by parameter 8921_)	ACM (baud rate determined by calibration)		
1	Connect ECM to the programming station (by itself - no other modules)	1	Connect ACM to the programming station (by itself - no other modules)
2	Use device tester to determine module baud rate. See section " Determining Module Baud Rate " for instructions.	2	Use device tester to determine module baud rate. See section " Determining Module Baud Rate " for instructions.
3	Use NavKal to program as a blank module to the vehicle's VIN.	3	Baud rate cannot be switched by dealer. Start Vehicle Programming case. Provide old & new ACM part numbers and buad rate of new ACM.
4	Use NED to verify parameter 8921_ (TP PROG Baud Rate) is set correctly		
5	If needed, use these templates (250k / 500k) to change 8921_ to correct baud rate. (If needed, see IK1200603 for NED template instructions)		

[Return to top](#)

OTHER RESOURCES

[Master Service Information Site](#)

[Vehicle Programming Resource Center](#)

[IK2600283 Vehicle Programming Information Associated with Engine: N9/N10 \(2014-2017\)](#)

 Hide Details

Feedback Information

Viewed: 105

Helpful: 3

Not Helpful: 0

No Feedback Found