

Aftertreatment Hydrocarbon Injector (AHI) Module Fuel Pressure Sensor

Service Category Service

Section Function Group 233

Technician Skill Level A

Market North America

Applicability

VOLVO

Years	Models
2024, 2025	VN(4), VN, VHD, VAH

Introduction

Volvo Trucks has determined that a select group of trucks were built with an AHI Module fuel pressure sensor which does not meet our specifications. A sensor that falls outside of specifications may result in diagnostic trouble codes (DTCs) and improper operation of the aftertreatment system. Please follow the instruction in this document to install an updated AHI fuel pressure sensor.

Production Change Information

This bulletin applies to vehicles built within the specified production changes below.

Brand	Engine	Emission Level	Starting Build Date	Ending Build Date
Volvo	D13, D11	EM-USA21, EM-USA24	8-December-2023	19-September-2024

Warranty Information

This repair is covered by an authorized Service Program. Reimbursement is obtained through the normal claim handling process.		
Claim Type (used only when uploading from the Dealer Bus. Sys.)	B	
Main Labor Code	Description	Hours
2339-03-02-05	Fuel Pressure Sensor Replacement	Time will vary by VIN. Refer to Impact for SRT amount.
Causal Part	22899626	
SCC Authorization Code	S4343	
Expiration Date	May 31, 2026	

Aftertreatment Hydrocarbon Injector (AHI) Module Fuel Pressure Sensor

Parts Information

Part Numbers	Part Names	Quantity
22899626	Pressure Sensor	1

Repair Procedure

1. Park the vehicle on level surface.
2. Apply parking brake.
3. Place the transmission in park or neutral.
4. Turn off ignition.
5. Install wheel chocks.

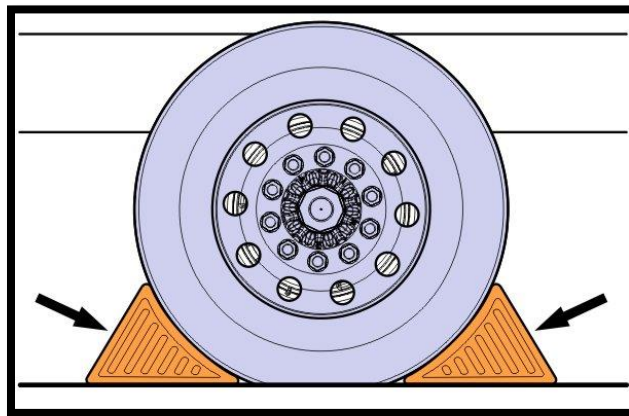

Aftertreatment Hydrocarbon Injector (AHI) Module Fuel Pressure Sensor

6. Decommission the low voltage system.
 - For all models **EXCEPT** for **VN(4)** model trucks only the cable from the negative terminal needs to be disconnected.

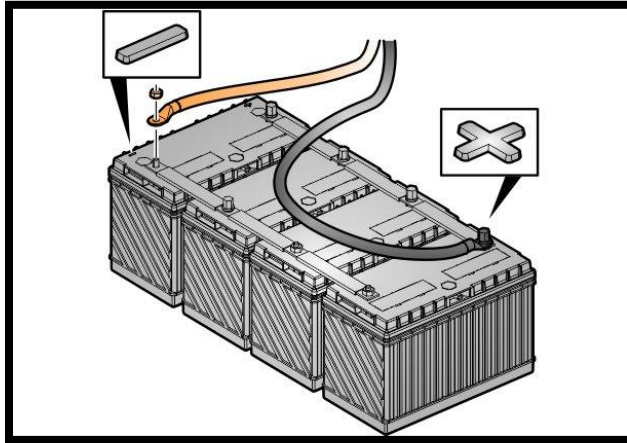

- For **VN(4)** model trucks please follow Impact operation 3100-09-01-06 Low voltage system decommissioning.
7. Unlatch and raise the hood.
 8. Disconnect the fuel pressure sensor connector.
 9. Move aside the harness.

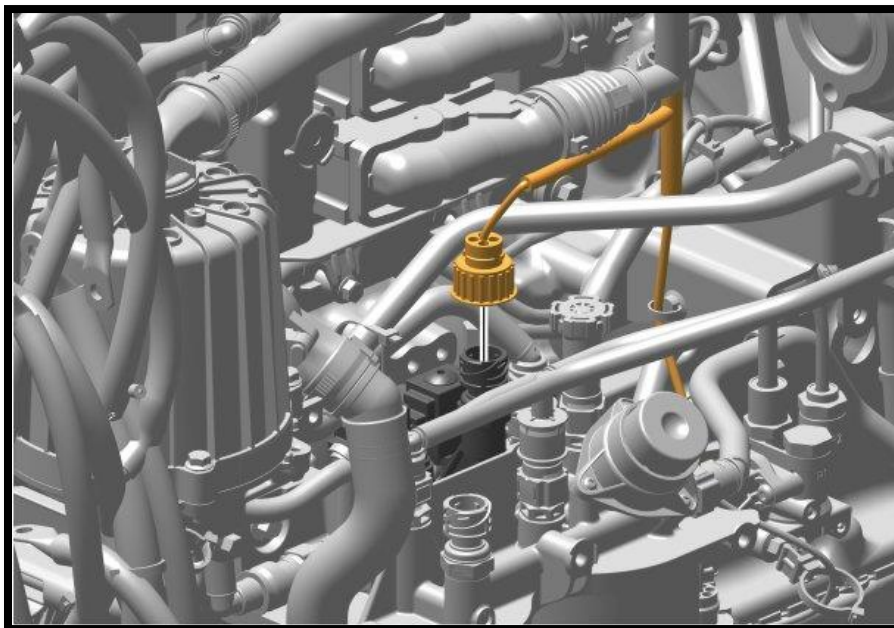

Aftertreatment Hydrocarbon Injector (AHI) Module Fuel Pressure Sensor

10. Clean the area around the sensor to prevent debris from entering the system.
11. Remove the sensor.
12. Remove the O-ring.

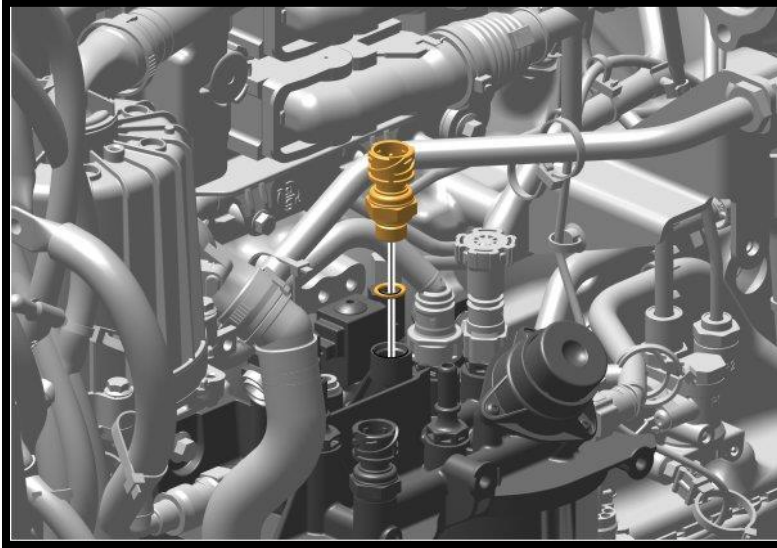

13. Install the new sensor.
14. Torque the sensor.

Tightening torque	
AHI (Aftertreatment Hydrocarbon Injector) pressure sensor	25 ±3 Nm (18 ±2 lb _r -ft)

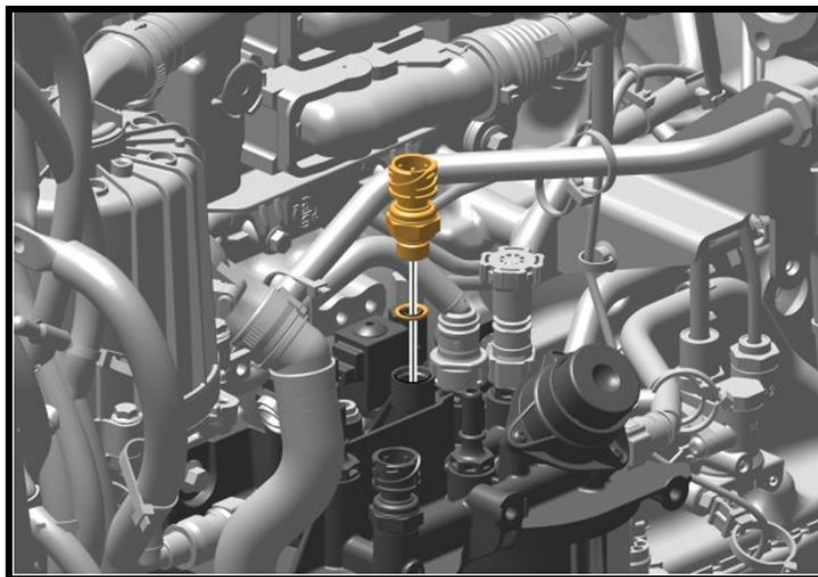

Aftertreatment Hydrocarbon Injector (AHI) Module Fuel Pressure Sensor

15. Connect the connector.

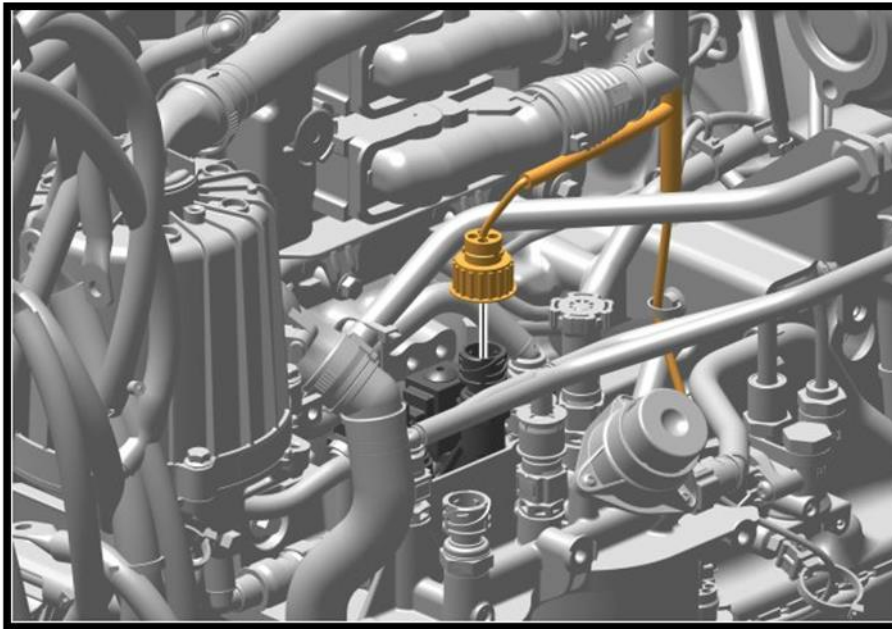

16. Commission the low voltage system.

- For all models **EXCEPT** for **VN(4)** trucks, connect the cable to the negative terminal.

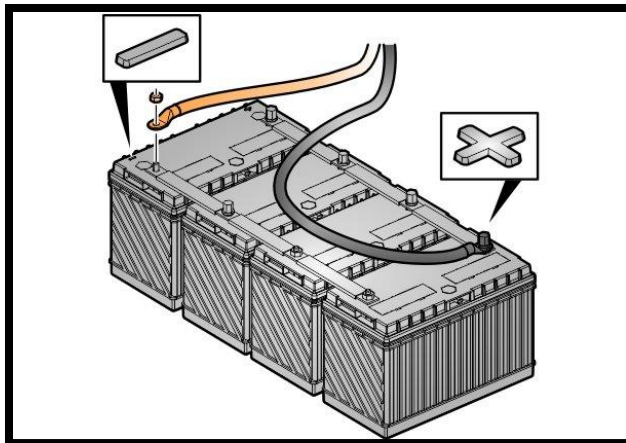

- For **VN(4)** model trucks please follow Impact operation 3100-09-01-05 Low voltage system commissioning.

17. Start engine.

18. Check for leakage.

19. Stop engine.

20. Lower and latch hood.

Aftertreatment Hydrocarbon Injector (AHI) Module Fuel Pressure Sensor

21. Connect to the latest version of PTT.

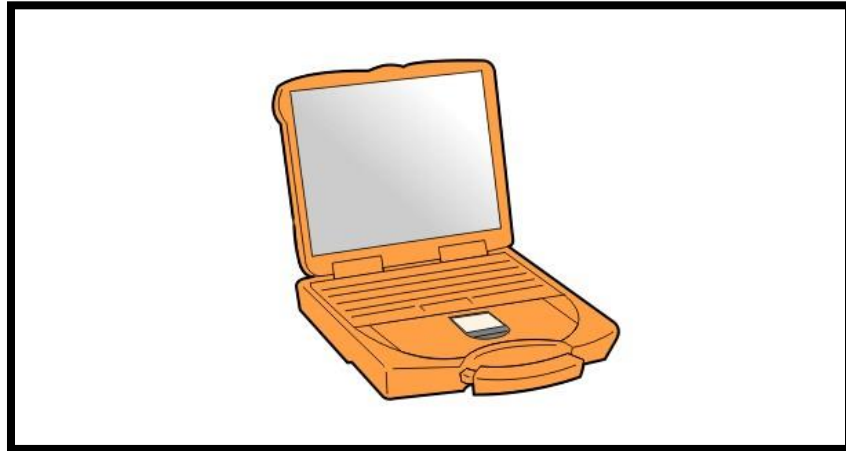

22. Clear any DTCs related to this repair.

23. Disconnect from PTT.

24. Remove wheel Chocks.

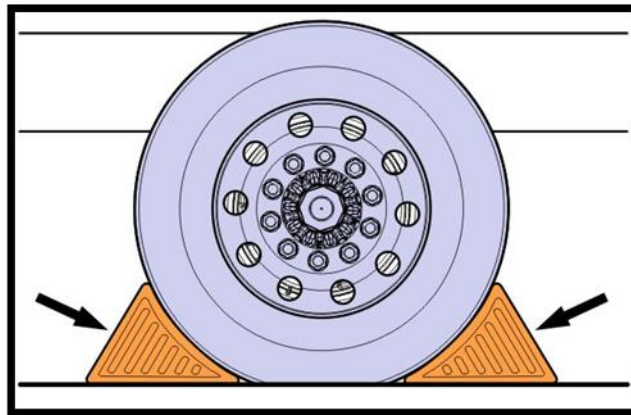

25. Release truck.