

February 18, 2026

Version 2

"Service Leveling System" Warning Message with DTC C1194 Air Reservoir Pressure Below Threshold

Supersedes Version 1 to revise the information at:

Service Bulletin title, updated.

APPLIES TO

Year	Model	Trim Level	VIN Range
2024	ZDX	TYPE S	ALL

SYMPTOM

Warning message "Service Leveling System" displaying on dash with an active C1194 DTC set against the K5 Automatic Level Control Module.

POSSIBLE CAUSE

The cause of the condition may be internal contamination of the Air Suspension Control Module Manifold.

CORRECTIVE ACTION

Perform inspection of air suspension system for leaks. If no leaks are found, replace Air Suspension Control Module Manifold.

PARTS INFORMATION

Part Name	Part Number	Quantity
Air Suspension Control Module Manifold	86587321	1

TOOL INFORMATION

Tool Name	Tool Number	Quantity
Air Suspension Inflator	07AAK-TYBA102	1

WARRANTY CLAIM INFORMATION

The normal warranty applies.

Operation Number	Description	Flat Rate Time	Defect Code	Symptom Code	Template ID	Failed Part Number
4145A6	Air Suspension Control Module Manifold replacement (Includes inspection and DTC clear)	2.2 hr	08103	03217	B26039A	86587321

Skill Level: Repair Technician

CLIENT INFORMATION: The information in this bulletin is intended for use only by skilled technicians who have the proper tools, equipment, and training to correctly and safely maintain your vehicle. These procedures should not be attempted by "do-it-yourselfers," and you should not assume this bulletin applies to your vehicle, or that your vehicle has the condition described. To determine whether this information applies, contact an authorized Acura automobile dealer.

INSPECTION PROCEDURE

CAUTION

Do NOT remove Automatic Level Control System components when the system is pressurized. Disconnecting a pressurized air line that is connected to an Automatic Level Control System component can cause personal injury and damage to components.

1. Enter service mode, use the vehicle's infotainment screen: **Settings > Vehicle > Suspension > Service Mode**, move the slider to the right to activate **Service Mode**.
2. Using the MDI2, [Verify the Pneumatic Connection Pressure Test passes, and the reservoir pressure is 4–20 bar.](#) **Control Function > Automatic Level Control Module > Pneumatic Connection Pressure Test > Select Enter**
3. Did the Pneumatic Connection Pressure Test Pass?
NO: Proceed to step 4.
YES: Proceed to step 9.
4. Install the air suspension inflator (P/N 07AAK-TYBA102) to the automatic level control air supply reservoir air valve and set the regulator on the nitrogen tank to 15 Bar.
5. Raise and support the vehicle.
6. Open the air suspension charger valve on the pressure gauge to fill the automatic level control air supply reservoir.
7. Fill the automatic level control air supply reservoir to 15 Bar.
8. Install the automatic level control air supply reservoir coupling cap and tighten 2 N·m (18 lb-in).
9. Inspect for damage, improper seating of air lines, evidence of water/ice, or leaks using soapy water on the following components:
 - Air Suspension Control Module Manifold



- Air Strut Fittings

Left Front



Right Front

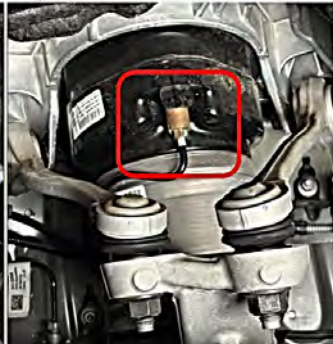

Left Rear



Right Rear



- Air line from the Air Suspension Control Module Manifold to the Automatic Level Control Air Supply Reservoir.

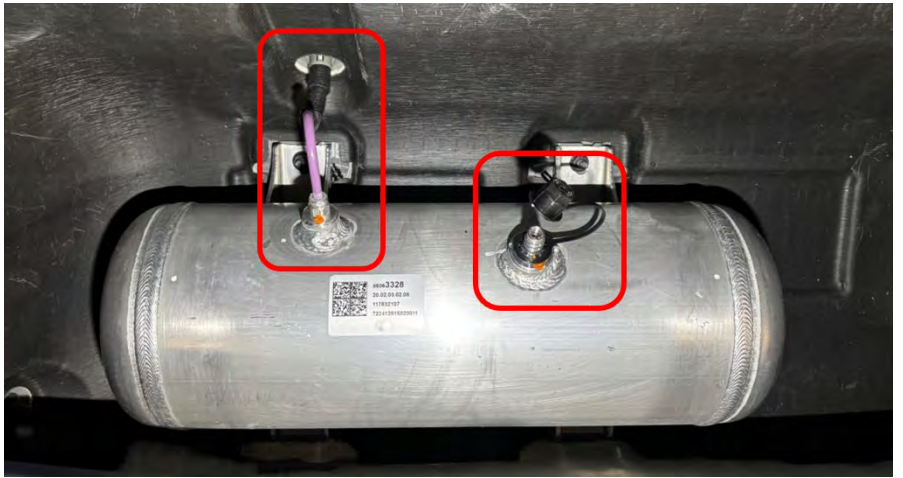

10. Was damage, improper air line seating, evidence of water/ice, or leaks found?

YES: This bulletin does not apply. Continue with normal troubleshooting.

NO: Proceed to **Repair Procedure**.

REPAIR PROCEDURE

1. Place hoists under lifting points to prevent vehicle from lowering when deflating Air Supply Reservoir
NOTE: DO NOT fully lower the vehicle to the floor until the air suspension has been fully pressurized. Lowering an air suspension vehicle without a charged system can cause severe damage to the air springs.
2. Connect the MDI2 scan tool to the deflate automatic level control air supply reservoir.
3. Deflate Air Supply Reservoir:
Control Function > Automatic Level Control Module > Complete Deflate > Air Supply Reservoir > Select Enter
NOTE: Repeat process as need to reach 1 bar. Deflating individual air springs is **NOT** necessary.
4. Remove the air intake line (1) from the body grommet.

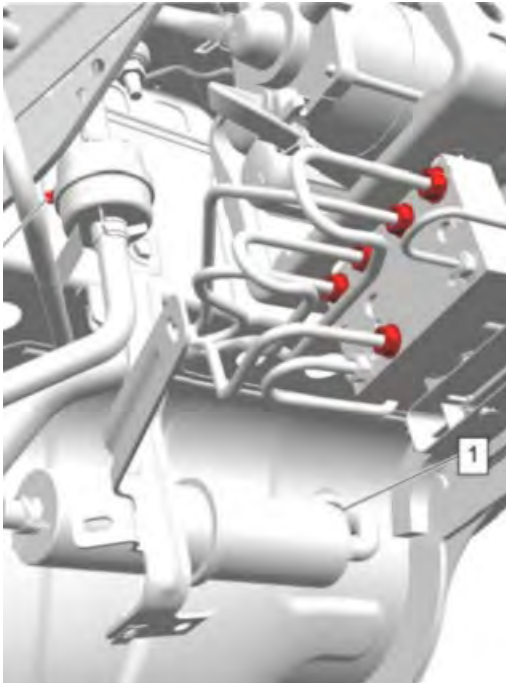

5. Remove the air line retainer clips (1).

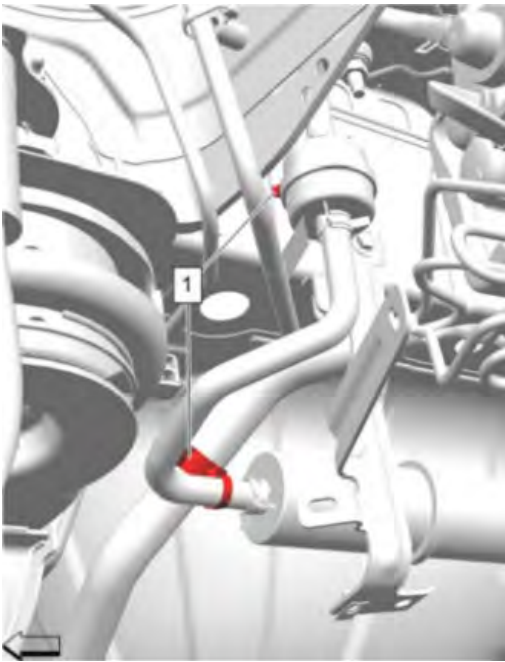

6. Remove the 7 air line nuts (1) from the air suspension controller.
NOTE: The air lines and air suspension controller are color coded to aid with installation

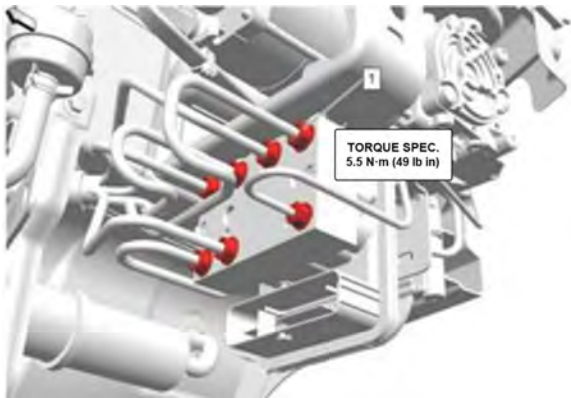

7. Disconnect the electrical connectors (2) and release the wiring harness retainers (1).

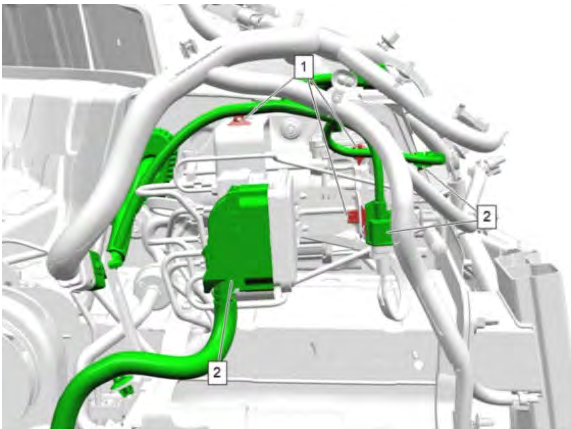

8. Remove Automatic Level Control Air Compressor hardware (1) and Automatic Level Control Air Compressor (2).

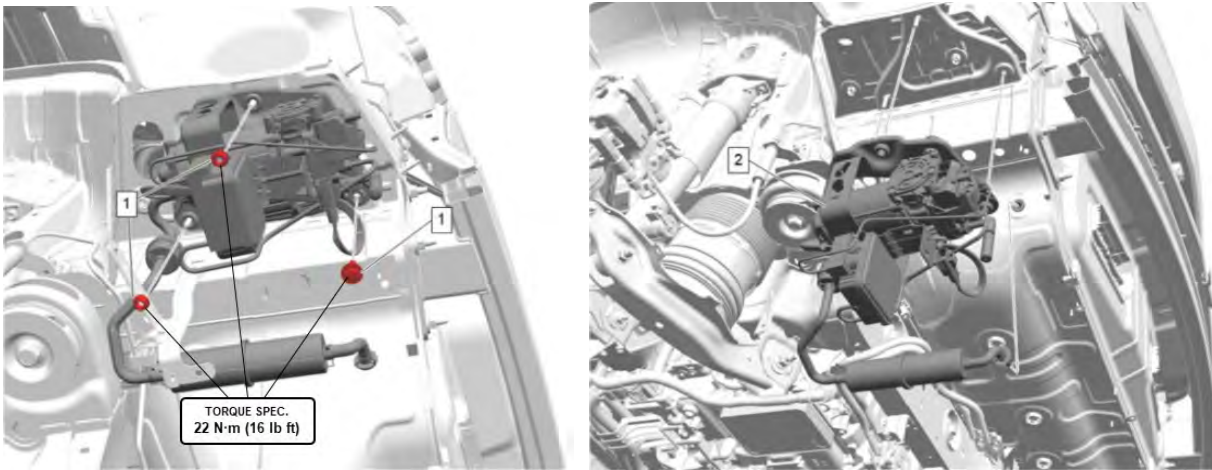

9. Remove Automatic Level Control Air Compressor (1) from Air Suspension Control Module Bracket.

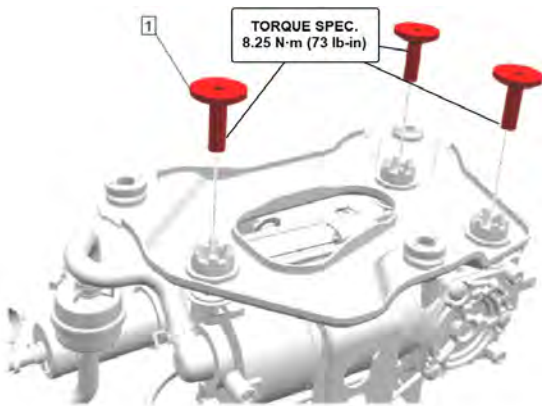

10. Remove Air Suspension Control Module Manifold assembly hardware.

BOLTS
5.65 N.m (50 lb-in)
Remove.



11. Separate the Air Suspension Control Module (2) from the Air Suspension Control Module Manifold assembly (1).

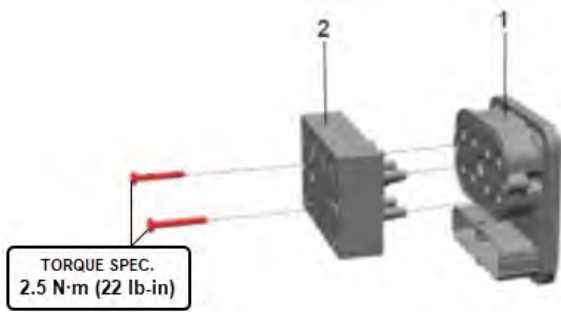

12. Replace the Air Suspension Control Module Manifold assembly, then torque bolts to 2.5 N·m (22 lb-in).
13. Install the Air Suspension Control Module Manifold assembly to the Air Suspension Control Module Bracket, then torque bolts to 5.65 N·m (50 lb-in)
14. Reinstall the Air Suspension Control Module Bracket, then torque hardware to 22 N·m (16 lb-ft).
15. Reinstall the 7 Automatic Level Control Air Compressor tube fittings to the Air Suspension Control Module Manifold Assembly, then torque lines to 5.5 N·m (49 lb-in).
16. Reconnect the electrical connectors and resecure the wiring harness retainers.
17. Remove the Automatic Level Control Air Supply Reservoir Coupling Cap (1).

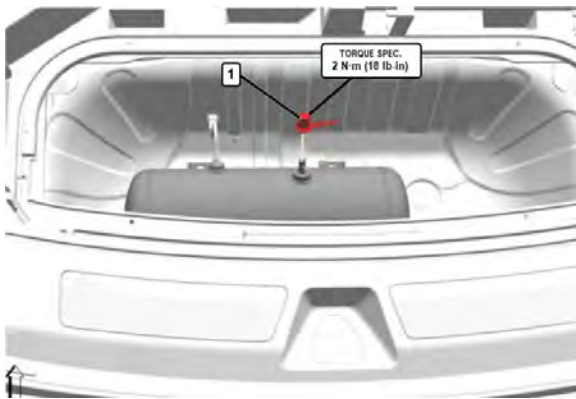

18. Install 07AAK-TYBA102 Air Spring Inflator to the automatic level control air supply reservoir air valve (2) and set the regulator on the nitrogen tank to 18 Bar (261 PSI).

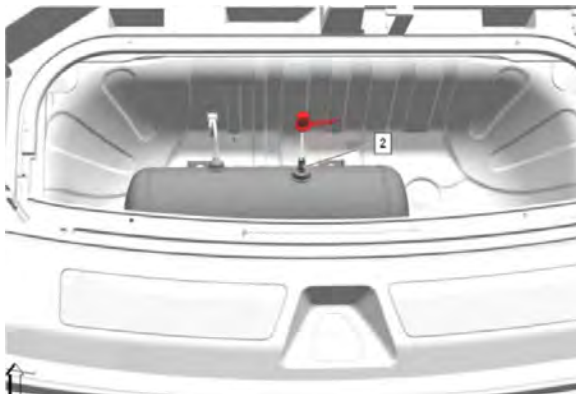

19. Open the valve on the pressure gage to fill the automatic level control air supply reservoir.
20. Using the shop nitrogen tank, fill the automatic level control air supply reservoir to 18 Bar (261.068 PSI).
21. Close the pressure gauge valve and remove Air Spring Inflator from the automatic level control air supply reservoir.
22. Install the automatic level control air supply reservoir coupling cap, then torque to 2 N·m (18 lb-in).
23. Partially raise the vehicle till the wheels are off the ground.

24. Using MDI2 tool, equalize the pressure in all air springs then use short-term inflate to increase pressure to the air springs:
 - Front: 7 Bar (101.526 PSI)
 - Rear: 7 Bar (101.526 PSI)
25. Using MDI2, verify automatic level control air supply tank pressure is at 18 Bar (261.068 PSI), if not repeat steps 17-23.
26. Reinstall Rear Compartment Floor Stowage Compartment Divider.
27. Clear DTC.
28. Verify DTC does not reset.