

February 13, 2026

Version 3

Emissions Recall: 2023 CR-V Hybrid Short Block Manufacturing Inspection

Supersedes Version 2 to revise the information at:

Under REPAIR PROCEDURE, step 51 was revised with new image.

AFFECTED VEHICLES

Year	Model	Trim Level	VIN Range
2023	CR-V Hybrid	ALL	Check iN for VIN Eligibility

BACKGROUND

Affected vehicles may be equipped with an incorrectly machined engine block at the crankshaft position sensor (CKP) mounting location. Vehicles may experience a no start condition, low speed rough idle, engine RPM hunting, or have the following DTCs set: P0017 (Camshaft Position (CMP) Sensor B and Crankshaft Position (CKP) Sensor Correlation) and P0339 (Crankshaft Position (CKP) Sensor Circuit Intermittent Interruption). This condition may affect a vehicle's compliance with California and Federal emissions standards and regulations.

CUSTOMER NOTIFICATION

Owners of affected vehicles will be sent a notification of this campaign. Do an iN VIN status inquiry to make sure the vehicle is shown as eligible.

Some vehicles affected by this campaign may be in your new or used vehicle inventory. Repair these vehicles before they are sold

CORRECTIVE ACTION

Inspect the block markings and if necessary, replace the short block and catalytic converter after obtaining Tech Line approval

PARTS INFORMATION

Expected failure rate is very low, orders for parts will be restricted. Once Tech Line validates parts are required after inspection, all required parts will be allocated to your dealership and an email will be sent with parts list and order reference number.

CUSTOMER INFORMATION: The information in this bulletin is intended for use only by skilled technicians who have the proper tools, equipment, and training to correctly and safely maintain your vehicle. These procedures should not be attempted by "do-it-yourselfers," and you should not assume this bulletin applies to your vehicle, or that your vehicle has the condition described. To determine whether this information applies, contact an authorized Honda automobile dealer.

REQUIRED MATERIALS

NOTE: Parts to make this repair are being allocated, but the Materials Required should be ordered via the normal parts ordering process after repair is authorized

Part Name	Part Number	Quantity
Honda bond (repairs 10 vehicles)	08718-0003, 08718-0004 or 08718-0009	1
Super High Temp Urea Grease (repairs 15 vehicles)	08798-9002	2.0-3.0 g (0.071—0.106 oz)
Honda Engine Oil: 0W-20	08798-9049	4.2 US qt (4.0 L)
Honda Long Life Antifreeze/Coolant Type 2	OL999-9011	8.5L (2.24 US gal)

TOOL INFORMATION

Part Name	Part Number	Quantity
Ball joint removal tool	07MAC-SL00202	1
Thread adapter	07AAF-SDAA100	1
Cam pins	07AAB-RWCA120	1
Crank socket	07JAA-001020A	1
Crank pulley tool	07MAB-PY3010A	1
Crank pully handle	07JAB-001020B	1
Crank seal remover (handle)	07749-0010000	1
Crank seal remover (socket)	07GAF-SD40200	1
Subframe jack	VSB02C000016	1
Subframe alignment tool	070AG-SJAA10S	1
Calipers	Commercially available	1
Lift table	KLS6227500	1
Sensor Depth Gauge	07AAJ-6MAA100	1

NOTE: The sensor depth gauge (07AAJ-6MAA100) was auto-shipped in July of 2023. If lost or misplaced, please contact the Special Tools Hotline at **(800) 346-6327**.

WARRANTY CLAIM INFORMATION

Operation Number	Description	Flat Rate Time	Defect Code	Symptom Code	Template ID	Failed Part Number
1235A1	Lower block machining lot inspection only	0.3 hr	6EY00	OEP00	A23049A	10002-69F-A01
A	Lower block cast date inspection - Add	0.1 hr			A23049B	
B	Inspection fixture air gap check - Add (Includes photos)	0.3 hr			A23049C	
1111EN	Inspection & replace short block (Includes inspection, steering sensor relearn & align)	13.1 hr	6EY00	OEP00	A23049D	10002-69F-A01
A	For AWD - Add	0.2 hr			A23049E	
B	Lower block cast date inspection - Add	0.1 hr			A23049F	
C	Inspection fixture air gap check - Add (Includes photos)	0.3 hr			A23049G	

Skill Level: Repair Technician

INSPECTION PROCEDURE

1. Lift the vehicle.

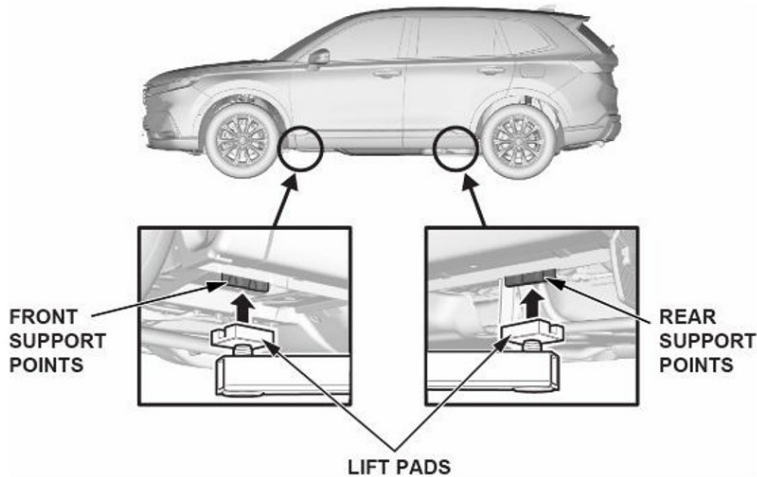

2. Remove the engine undercover plate.

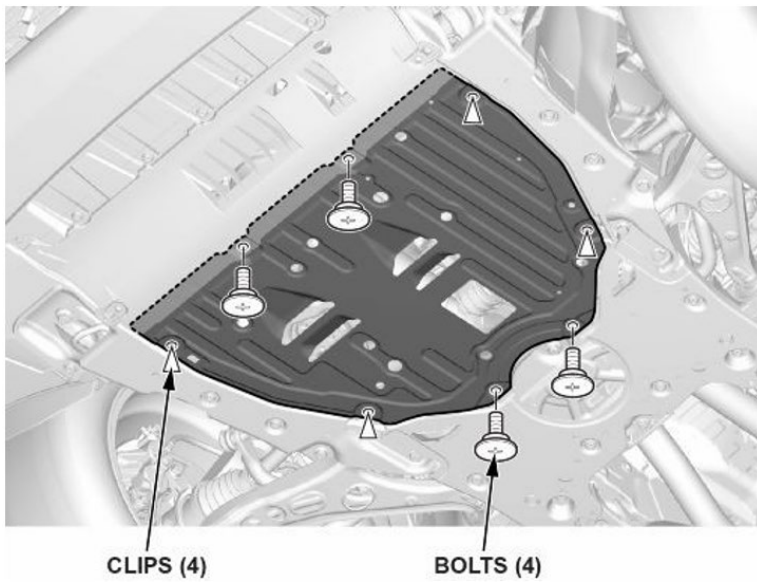

3. Inspect this location for either L or K manufacturing stamp.

NOTE:

- If L, install removed parts in reverse order, inspection is done and complete.
- If K, continue to the next step in the inspection procedure.

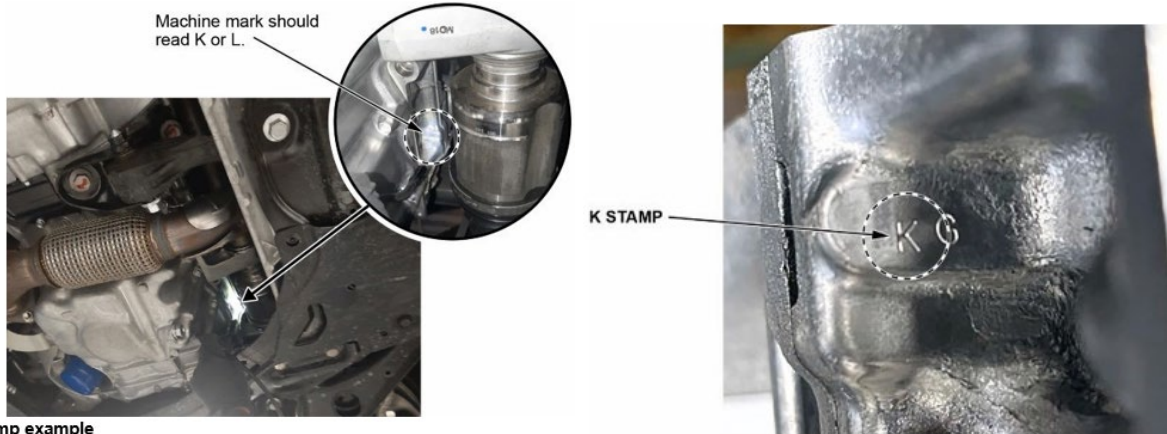

4. Locate the cast date stamp above the catalytic converter bracket



5. Take a picture of the lower block casting bar code.

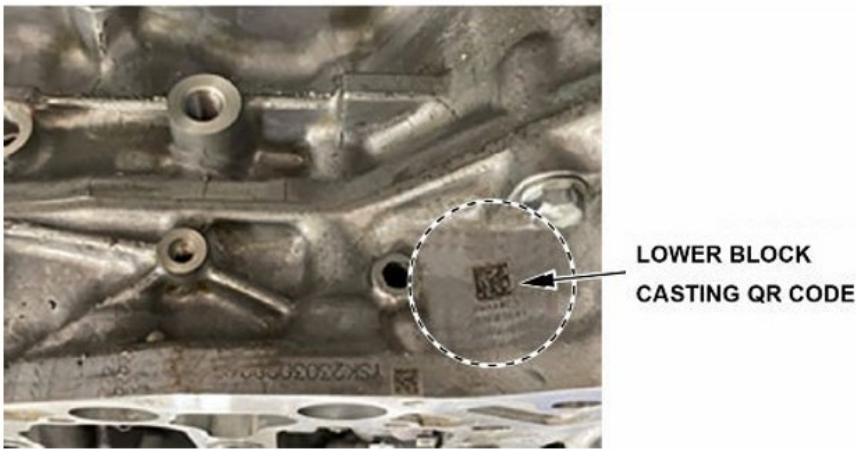

6. Inspect the block the manufacturing date:

- **If before 3/4/23** continue with next step.
- **If after 3/5/23** this repair does not apply, reassemble.

Example:

Block date reader info:

Year	2=2022, 3 = 2023
Month	1=JAN, 2=FEB, 3=MAR, 4=APR, 5=MAY, 6=JUN, 7=JUL, 8=AUG, 9=SEP, X=OCT, Y=NOV, Z=DEC
Day	01 ~ 31

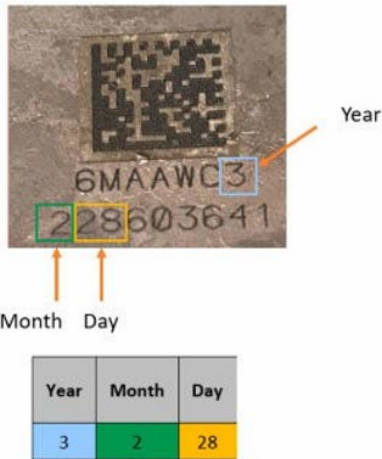

7. Turn the crankshaft to align the white mark on the crankshaft pulley with the pointer on the cam chain case.

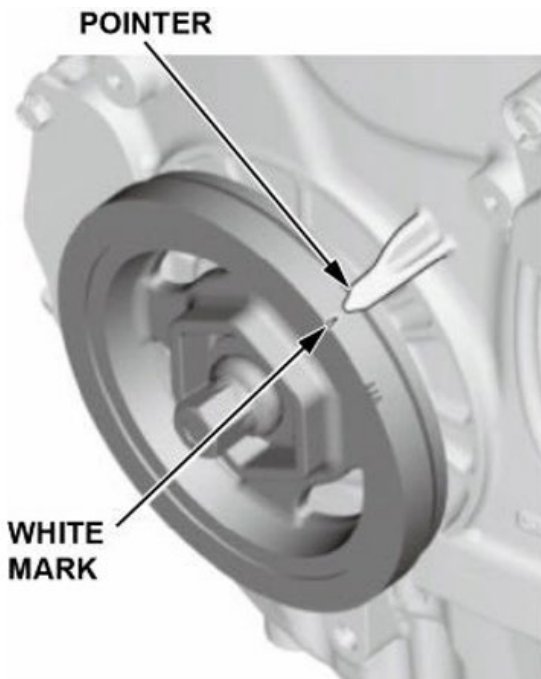

8. Remove the CKP sensor cover.

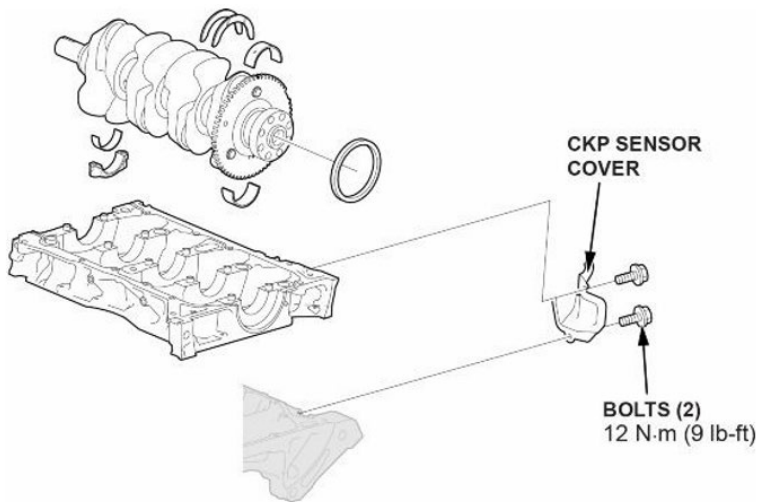

9. Remove the CKP sensor.

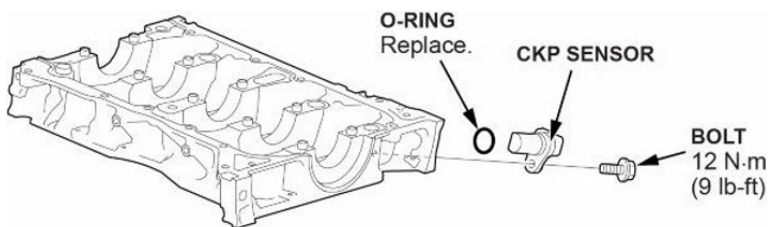

10. Insert the inspection tool and torque the inspection fixture bolt to **12 N·m (9 lb-ft)**.

NOTE: Measurement with the inspection tool can only be done with the crankshaft set to TDC.

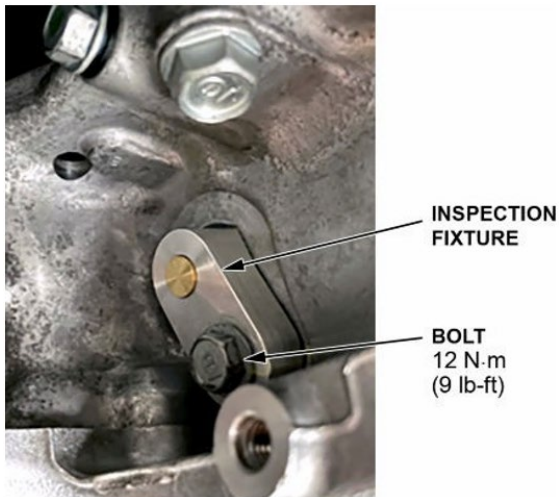

11. Using a straight edge, take a clear picture that shows if the brass piece of the tool is recessed or protruding.

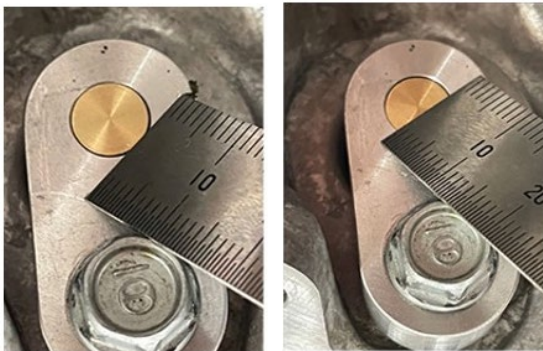

12. Upload the photo using the Tech Line Image Uploader on the iN.

NOTE: In the Tech Line reference no. field, use your dealer number + 0. Then select **Tech_Line** on the dropdown menu for agent name and complete the rest of the form

* = Required

Tech Line Image Upload

DPTS ID* -

Tech Line Reference No.

Tech Line Agent Name*

Vehicle Information

VIN*

Mileage

Model

Model Year

Comments

Image Upload

Images Uploaded 0 [Image Upload](#) [View Image](#)

For video or large photo files, email them to techline@ahm.honda.com. A Tech line reference number or VIN and dealer number MUST be included in the subject line when sending files to Tech Line

13. Create a Tech Line contact using iN and call Tech Line to review the photos and repair directions. Tech Line will advise to proceed to the REPAIR PROCEDURE or reassemble

REASSEMBLE PROCEDURE

1. Install the CKP sensor with new O-ring.

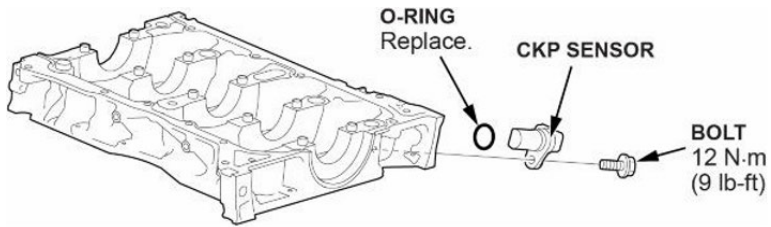

2. Install the CKP sensor cover.

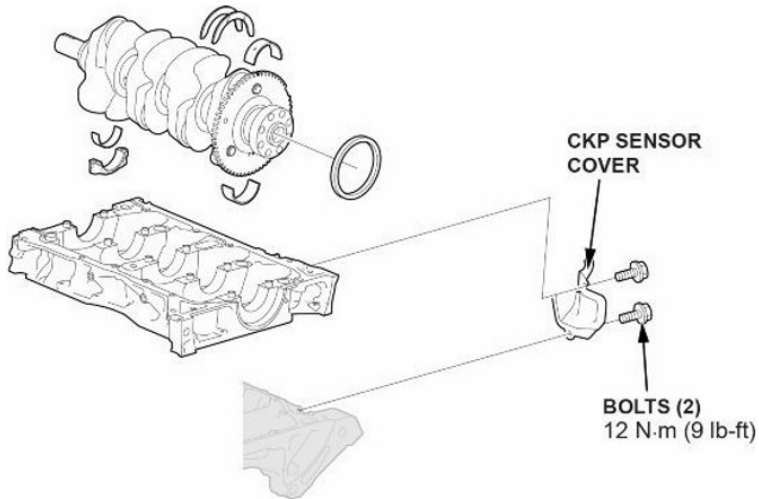

3. Install the engine undercover plate.

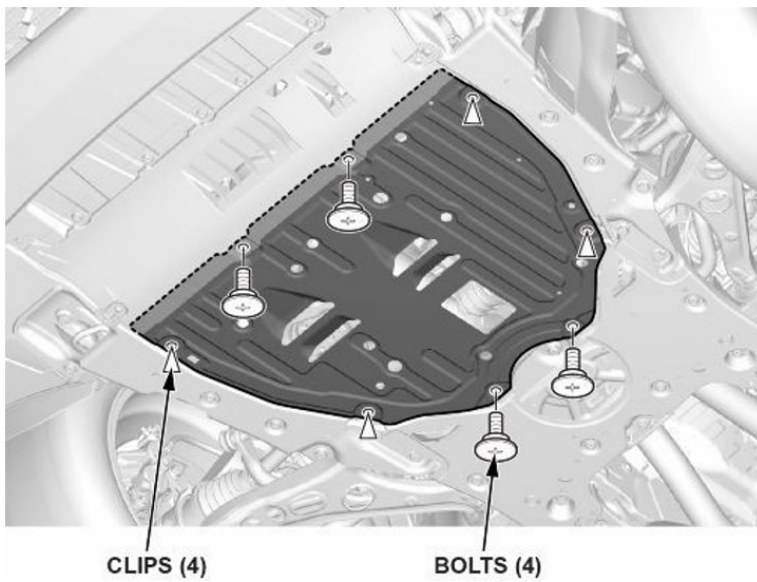

⚠ WARNING

- The power cables carry high voltage when the electric powertrain system is energized. To avoid serious injury from electrical shock, do not turn on the system with the power cables disconnected.
- Wear insulated gloves and use insulated tools to protect you from electrical shock. When removing or installing high voltage items, always use them. Wrap the high voltage items with insulating tape after removing. Please be careful when you see ⚠ on the illustration.

1. Open the hood and secure it with the hood support rod in the wide-open position.

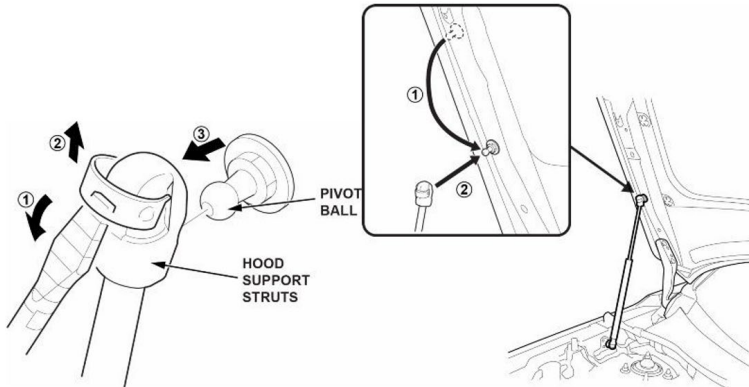

2. Turn the vehicle off.
3. Remove the vehicle emergency fuel funnel, and insert it into the fuel filler neck to relieve the pressure in the fuel tank.

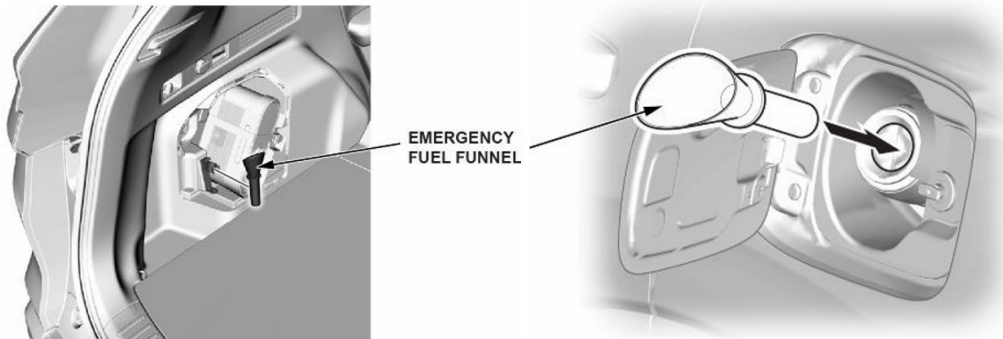

4. Remove PGM-FI main relay 2.

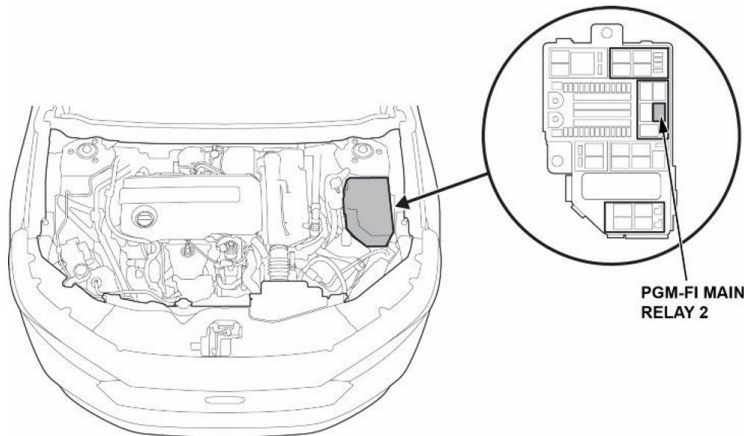

5. Enter maintenance mode, and start the engine, then idle until it stalls.
6. Install PGM-FI main relay 2.
7. Open the rear hatch.

8. Remove the 12 volt negative battery terminal. Then, remove the positive battery cable.
NOTE: Do not hold the 12 volt battery sensor connector when disconnecting the negative terminal.

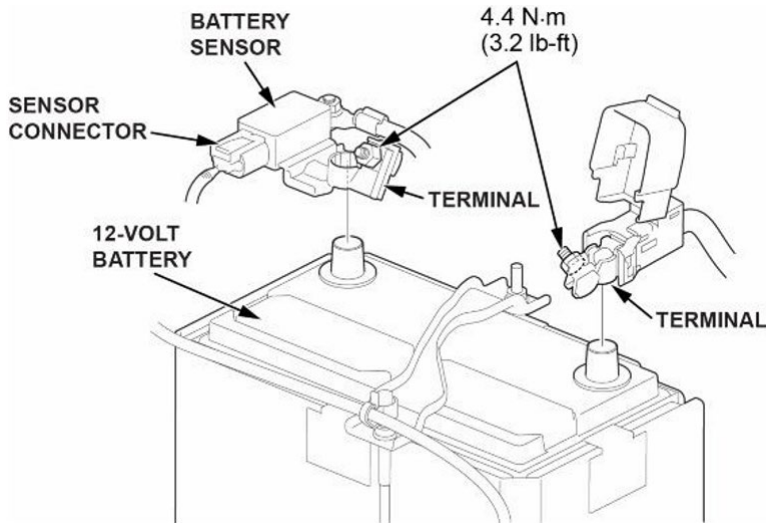

9. Remove the cargo lid floor.

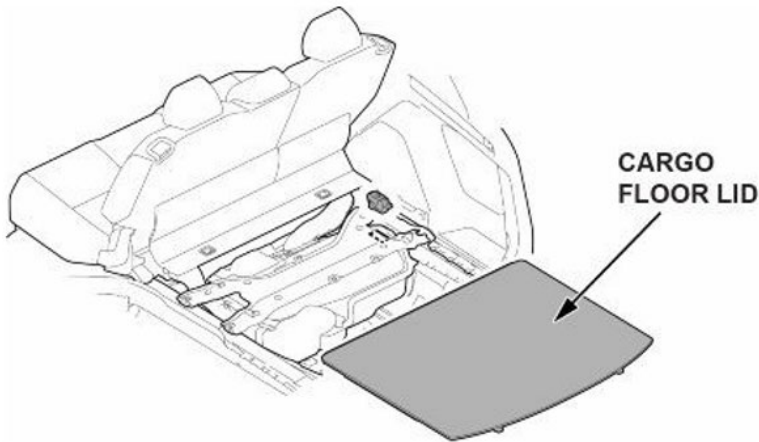

10. Remove the service plug lid.

⚠ WARNING

- The power cables carry high voltage when the electric powertrain system is energized. To avoid serious injury from electrical shock, do not turn on the system with the power cables disconnected.
- Wear insulated gloves and use insulated tools to protect you from electrical shock. When removing or installing high voltage items, always use them. Wrap the high voltage items with insulating tape after removing. Please be careful when you see ⚠ on the illustration.

NOTE:

- Read the electric powertrain service precautions before doing any repairs or service.
- The following procedure should be done before work on or near any energized high voltage components. Follow the procedure exactly. Otherwise, you may be injured or may damage equipment.
- The electric powertrain is a high-voltage system.
- You must be familiar with the electric powertrain system before working on or around it.

11. Remove the Service Plug lid.

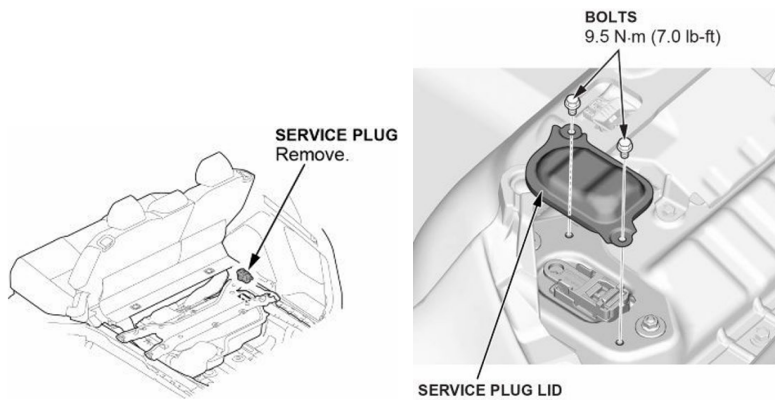

1. Push the tab and cancel the catch. Then, slide the tab to the unlocked position until a click is heard.

NOTE:

- Operate with the tab.
- Do not insert a finger in the gap to let the tab slide.

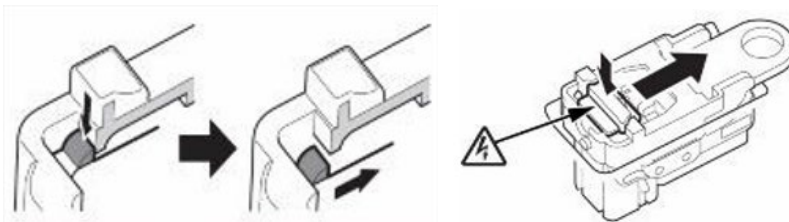

2. Raise the lever, and remove the service plug

NOTE:

- Secure the service plug in a safe location to prevent other personnel from installing the service plug while the vehicle is being repaired or serviced.
- If the service plug is damaged, replace it.

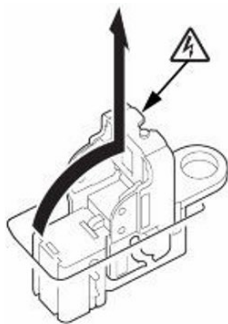

3. Wrap the service plug base with insulating tape.

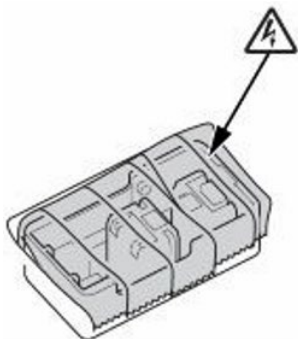

12. Remove both front wheels.

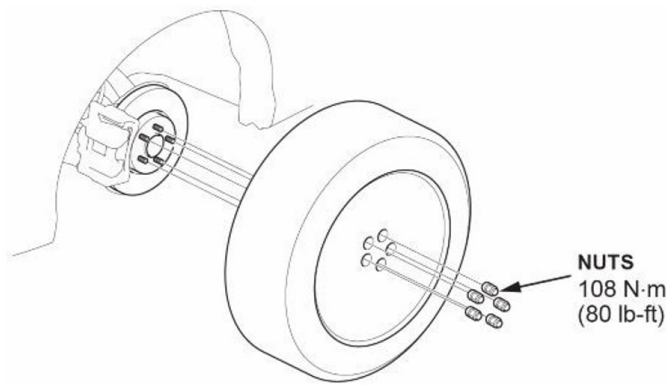

13. Remove the engine cover.

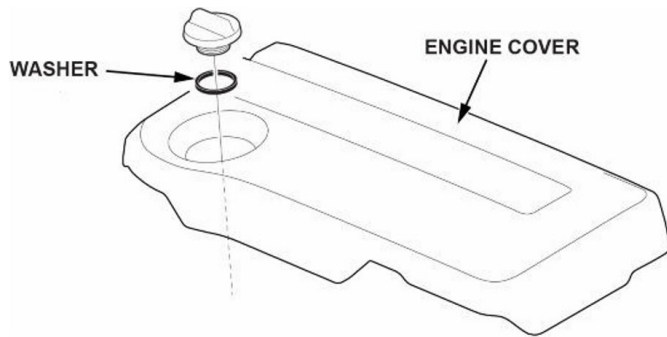

14. Remove air cleaner parts.

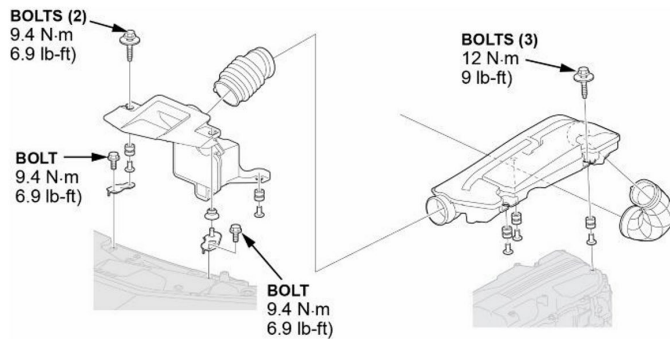

15. Remove 12 volt battery box.

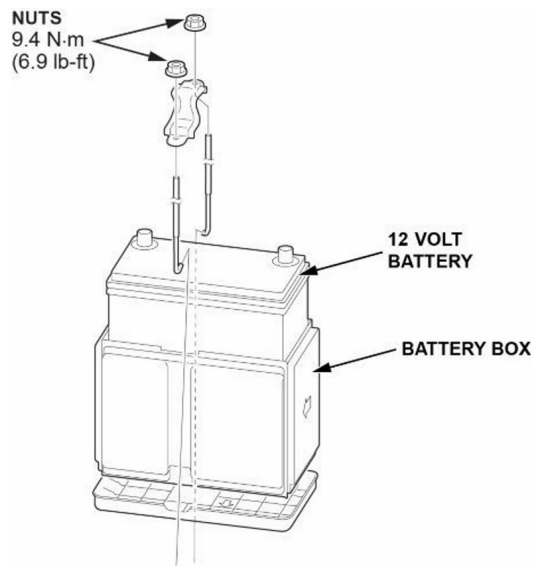

16. Remove the steering joint.

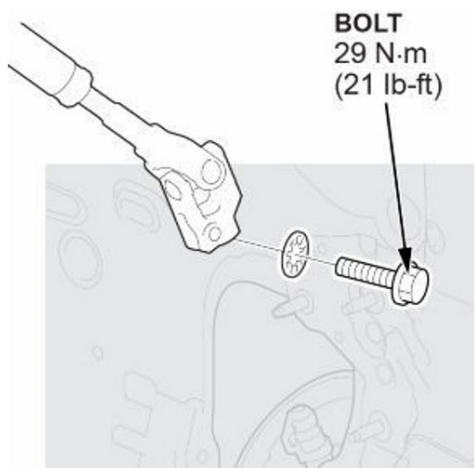

17. Wait until the engine is cool, then carefully, remove the radiator cap
18. Lift the vehicle, and remove the engine undercover.

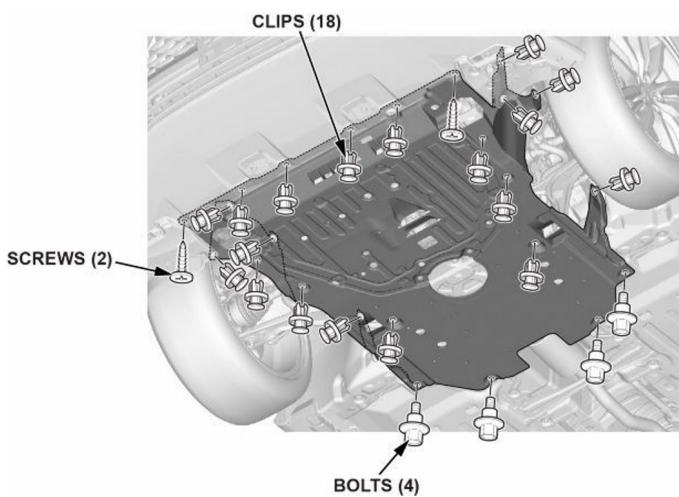

19. Remove the bolt, to drain the oil.

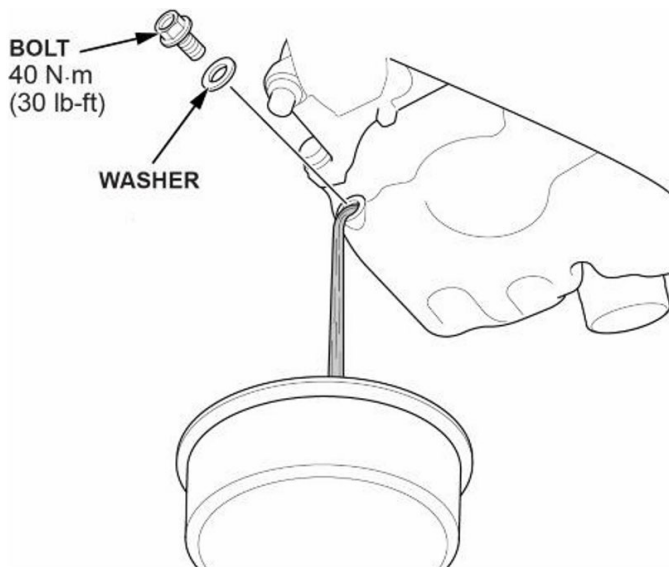

20. Remove radiator drain plug, to drain the engine coolant.



21. Attach a tube. Then, drain the PCU coolant.

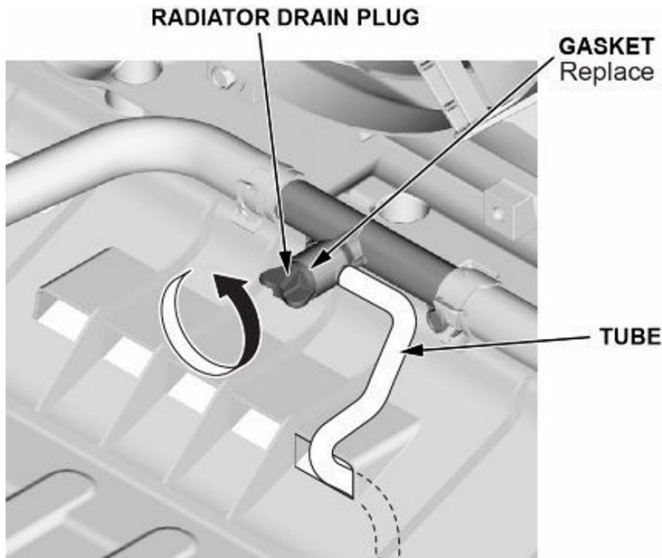

22. Disconnect exhaust pipe A.

NOTE: Tighten the radiator drain plug securely with a new O-ring.

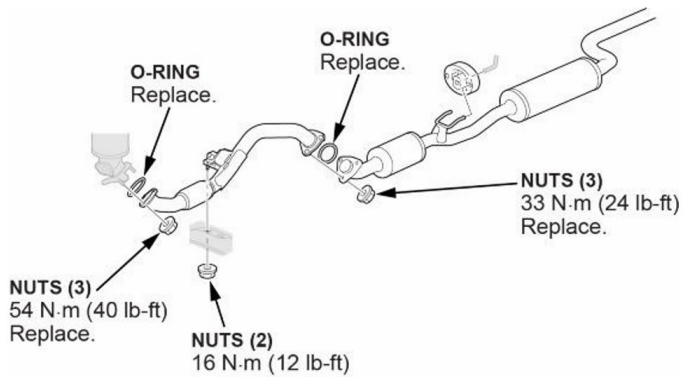

23. Disconnect the EPS Connector.

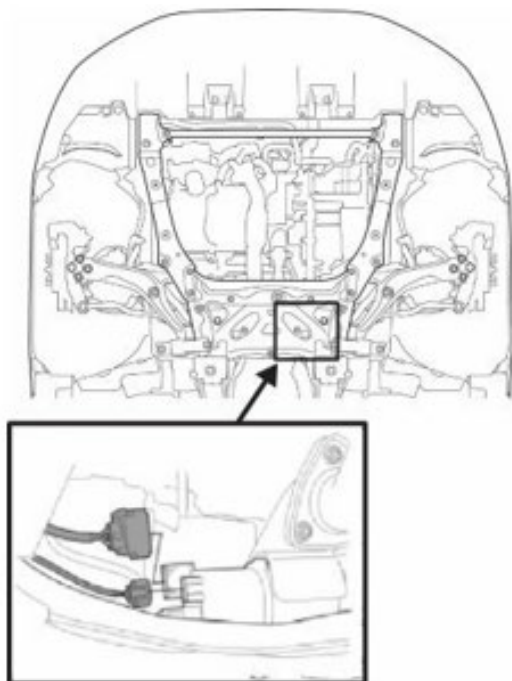

24. Disconnect the lower sway bar bolt, and repeat on the other side.

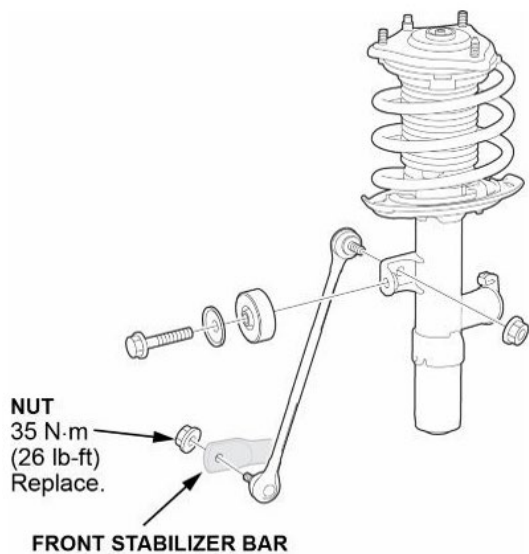

25. Disconnect the front lower arm nuts, and repeat on the other side.

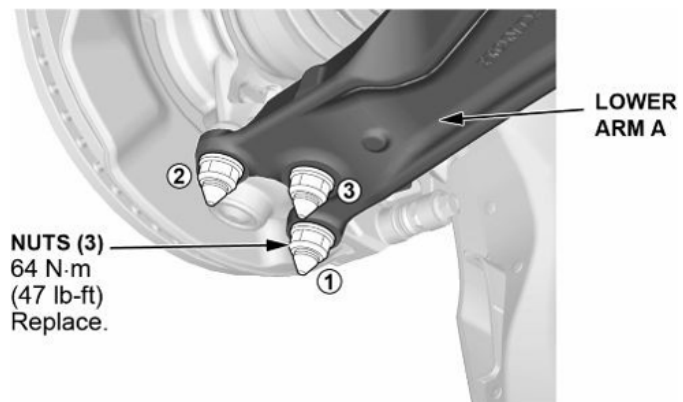

26. Disconnect the tie-rod end ball joint nut, and repeat on the other side.

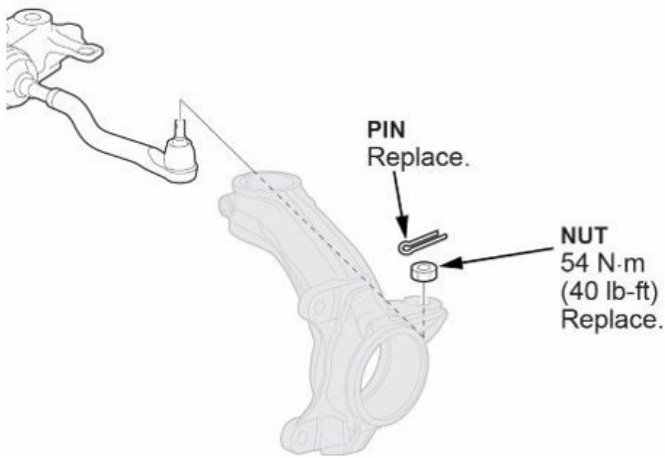

27. Remove the axle nuts, and repeat on the other side.

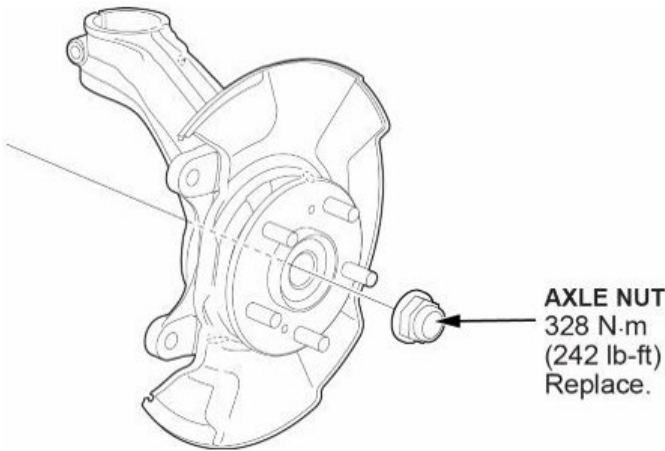

28. Remove the left front axle.

1. Remove the outer axle

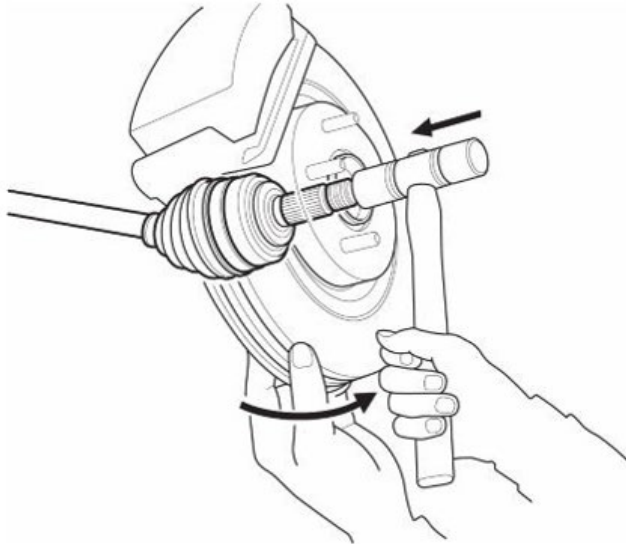

2. Pry the inboard joint using a pry bar

NOTE: Be careful not to damage the oil seal or the end of the inboard joint with the pry bar.

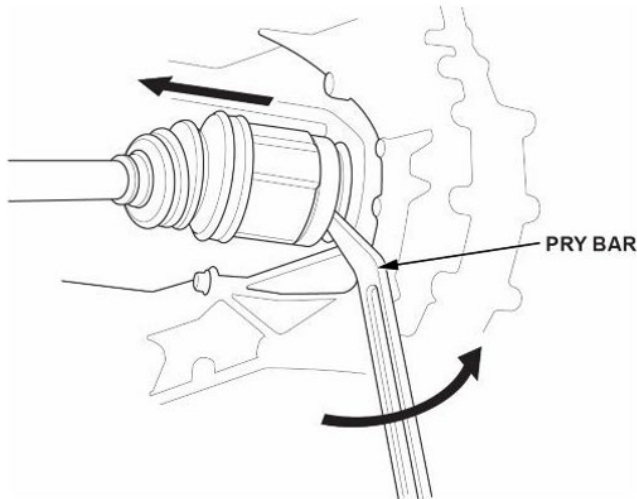

3. Remove the driveshaft as an assembly

NOTE: Do not pull on the driveshaft, or the inboard joint may come apart. Pull the inboard joint straight out to avoid damaging the oil seal.

29. Remove the right front axle.

1. Remove the outer axle.

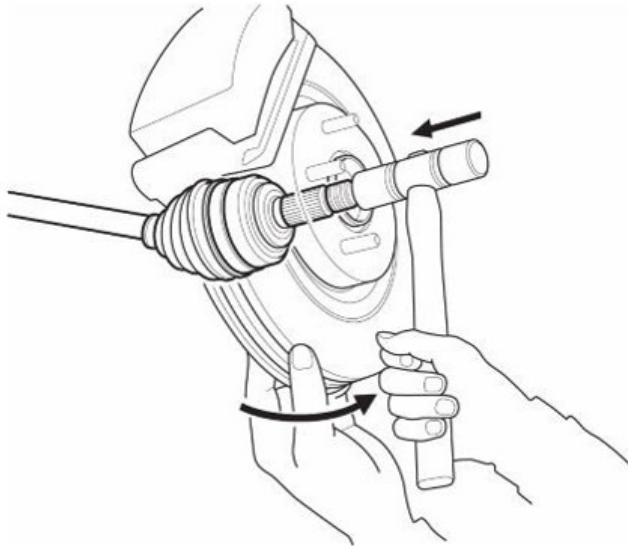

2. Drive the inboard joint off of the intermediate shaft using a drift punch and a hammer.

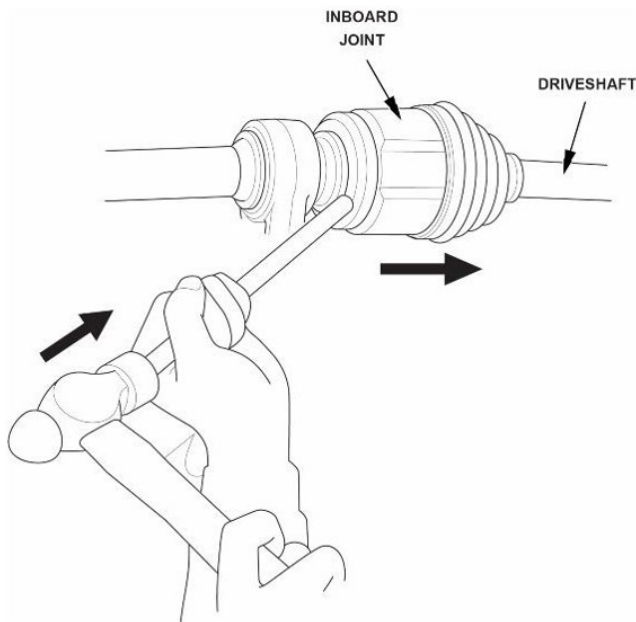

3. Remove the driveshaft as an assembly.
NOTE: Do not pull on the driveshaft, or the inboard joint may come apart. Pull the inboard joint straight out to avoid damaging the oil seal.

30. Remove the Intermediate Shaft.

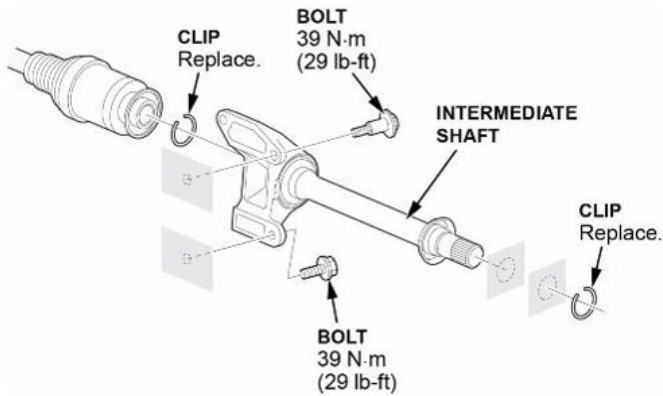

31. Remove engine PCM wire harness.

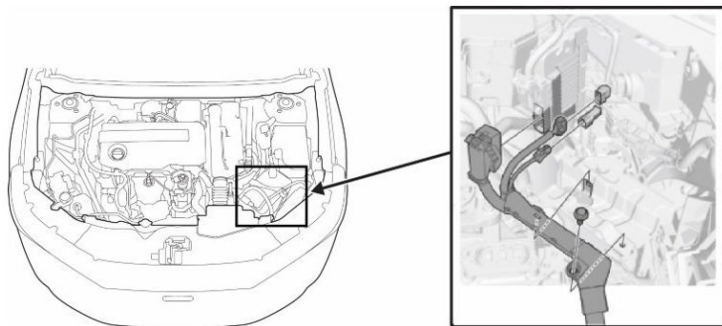

32. Remove the PCU assembly.

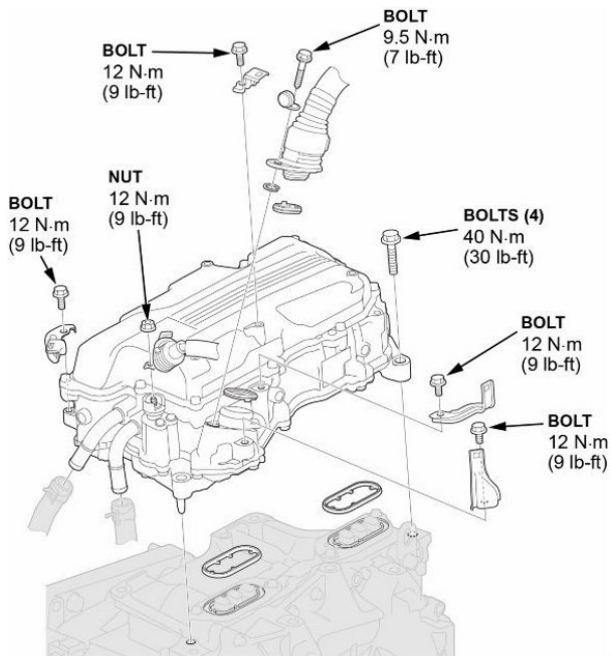

1. Disconnect the PCU connectors, and wrap with insulating tape.

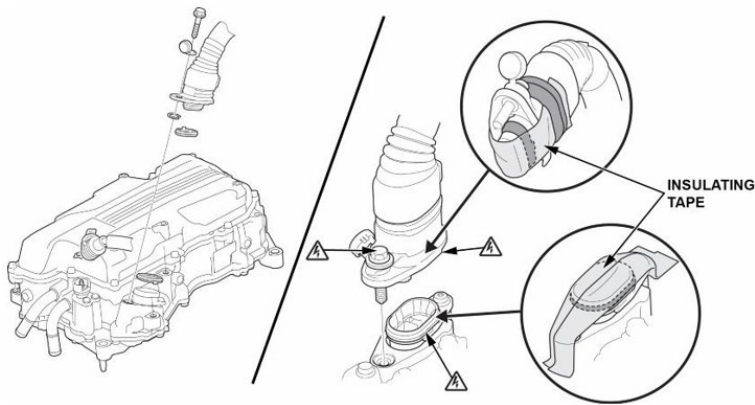

2. Cover the PCU connector using a rag or shop towel.
NOTE: Do not wrap around the insulating tape on the sealed part
3. Remove the PCU coolant hoses.
4. Remove the PCU.

33. Disconnect the rear heater hoses.

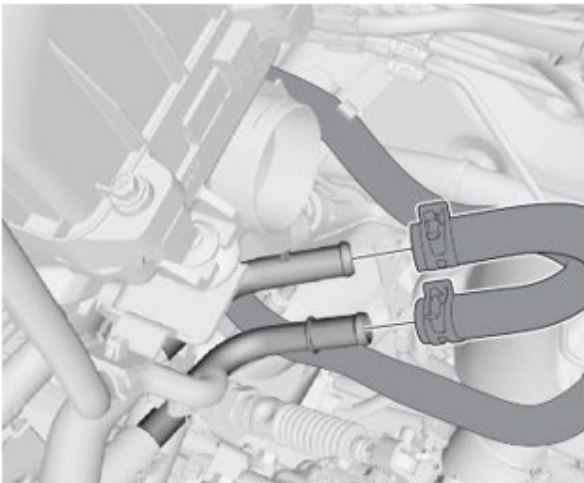

34. Disconnect the shift cable (transmission e-CVT side).

1. Remove the cable bolt.

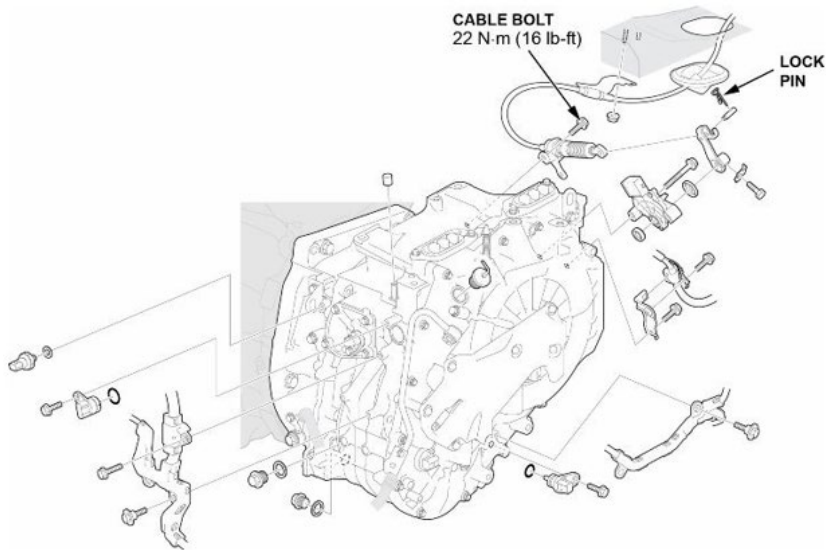

2. Remove the lock pin.

35. Remove the front grille cover.

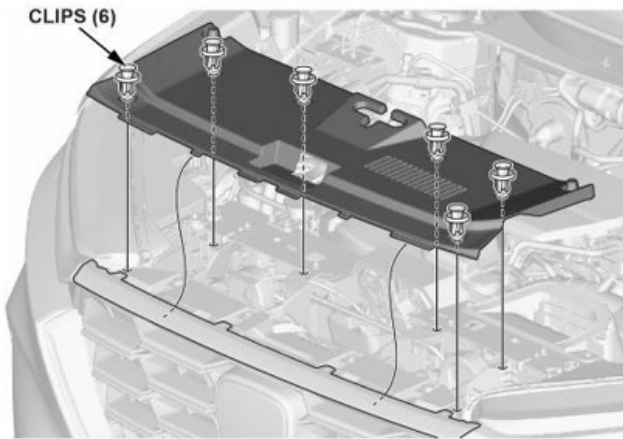

36. Disconnect the upper and lower radiator hoses from the engine.

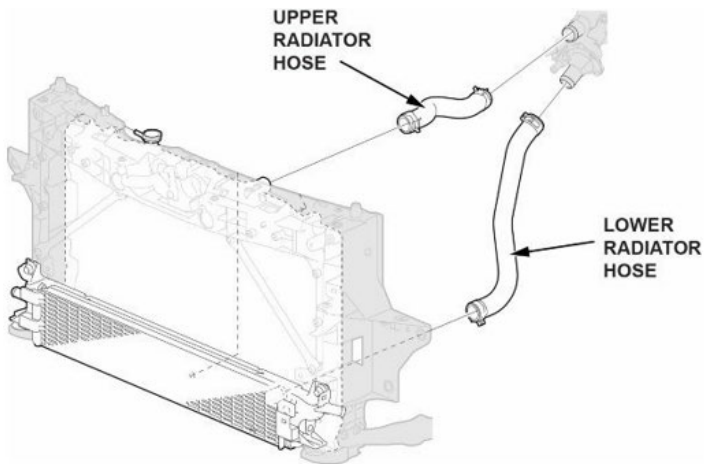

37. Remove the EGR pipe.

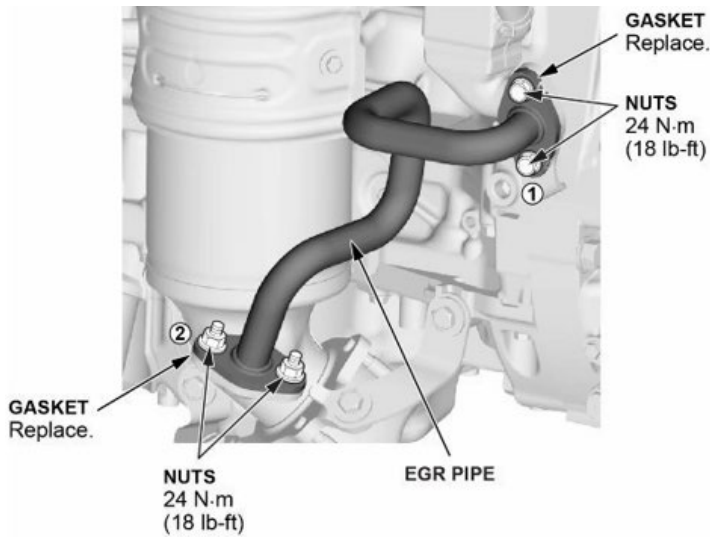

38. Remove catalytic converter.

NOTE: Due to the high temperatures of the exhaust system, the exhaust nuts, studs, and bolts may seize preventing easy removal. If you encounter a seized condition, do the following:

1. Apply rust penetrant to the nut/stud or bolt.
2. Allow the penetrant to sit; the amount of time may vary.
3. Lightly tap the nut/stud or bolt with a hammer.
4. Slowly loosen the nut or bolt.
5. If the nut or bolt still will not loosen, repeat steps 38.1 to 38.4.

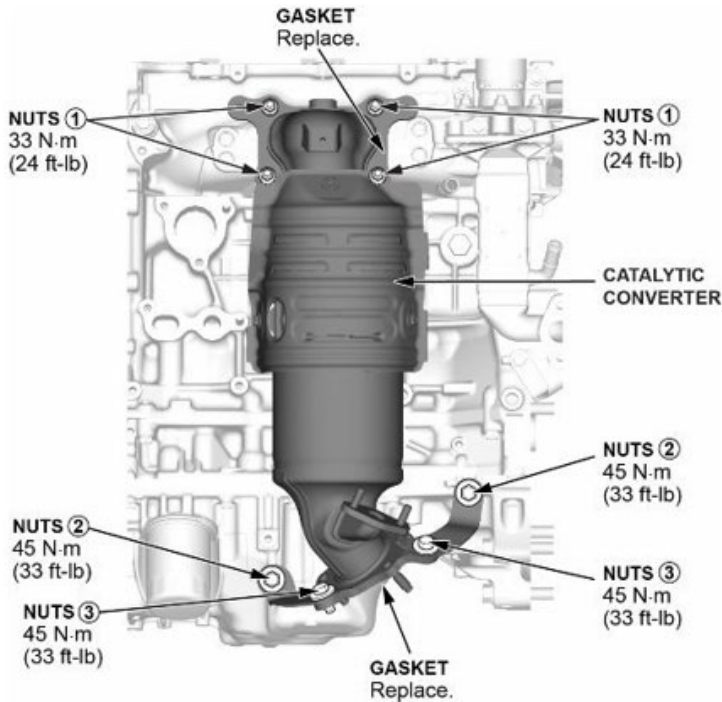

39. Remove the passenger's side radiator fan.

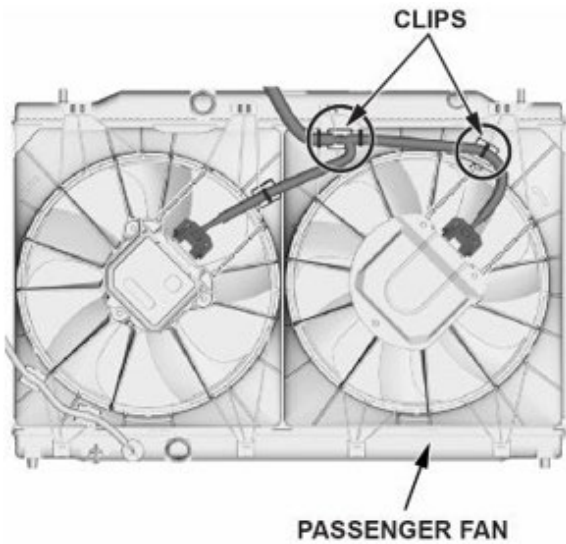

40. Disconnect the A/C connector.

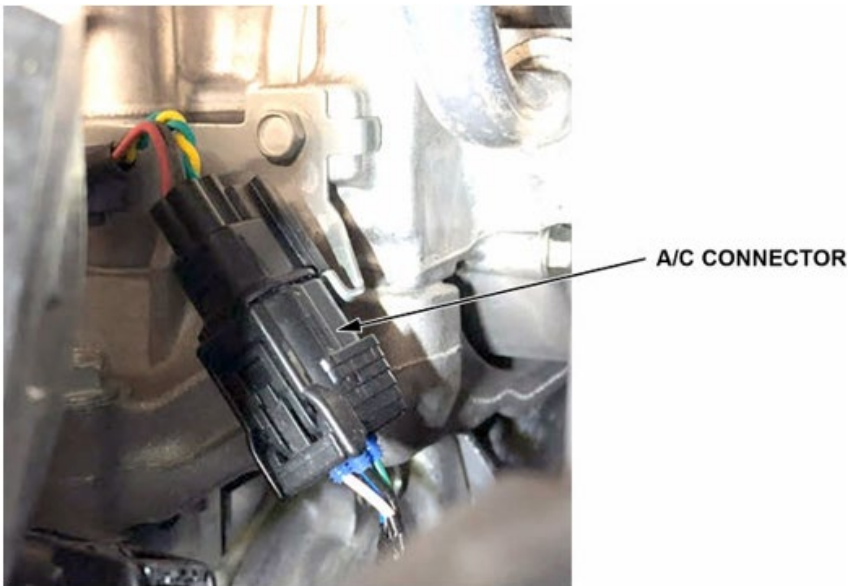

41. Remove the A/C compressor outer bracket, and move the compressor to the side.
NOTE: Hang the electric A/C compressor with a zip-tie. Do not remove the A/C hoses.

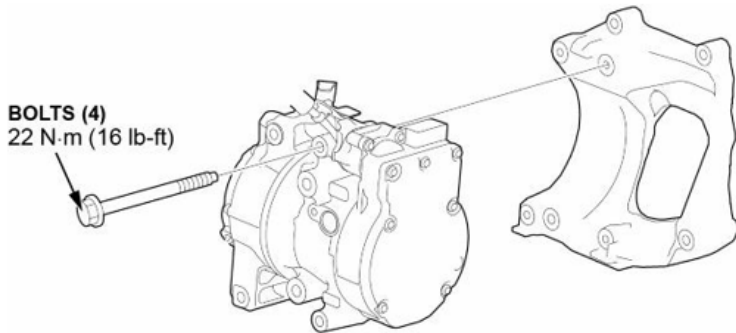

42. Remove the propeller shaft.
NOTE: Applies to AWD vehicle, only.

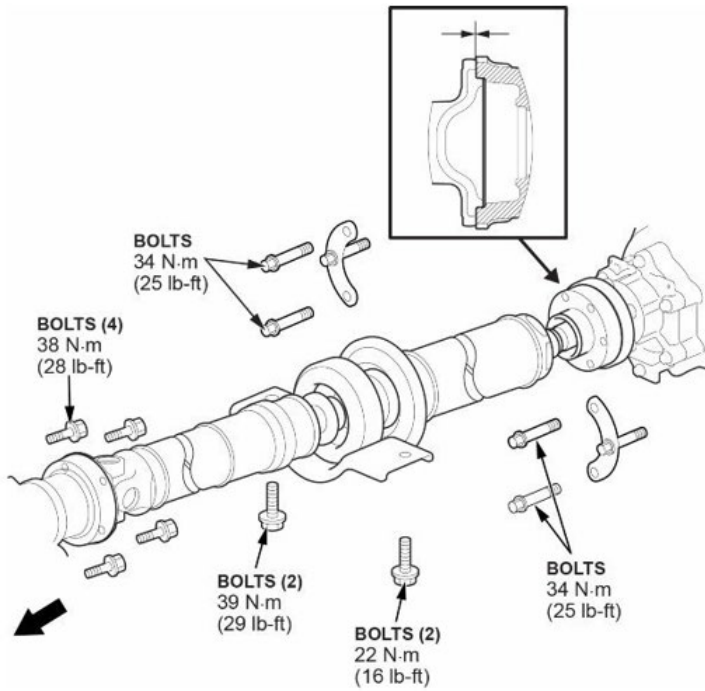

43. Disconnect the fuel line and fuel purge hose.



44. Lift the vehicle and remove the torque rod.
NOTE: Leave the engine mount attached to the engine, to support the engine when removing the torque rod.

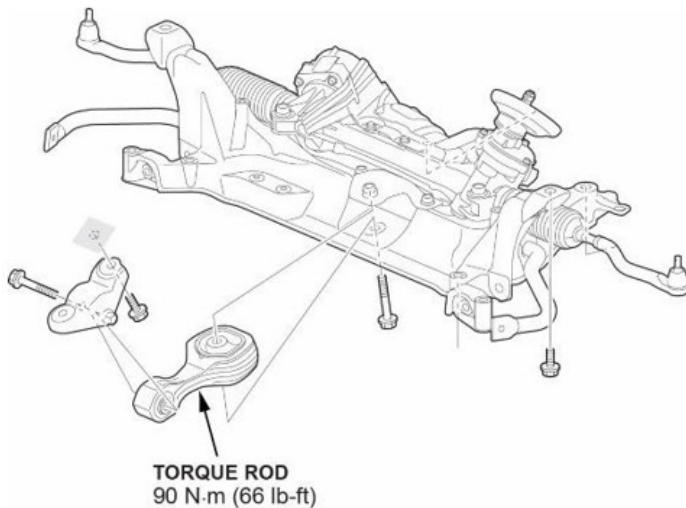

45. Remove the transmission ground.

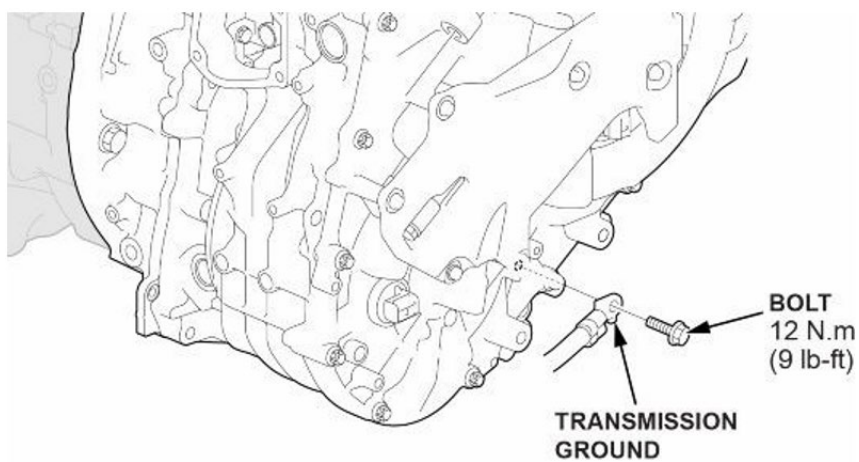

46. Disconnect the transmission connector and release the harness from the subframe.

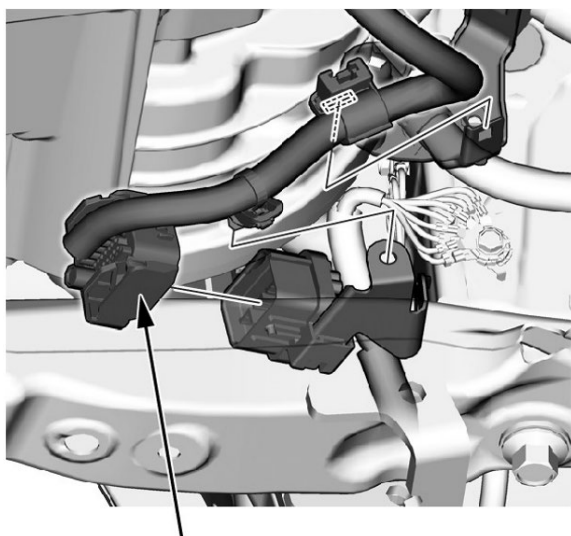

CONNECTOR

47. Disconnect the transmission hoses.

TRANSMISSION HOSES
Disconnect.

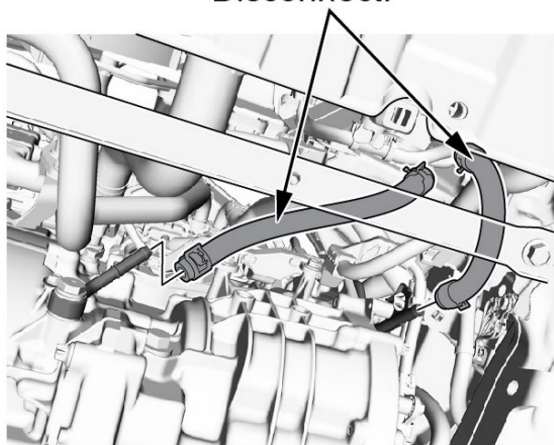

48. Disconnect the transmission hoses.
 NOTE: During installation follow the steps below:
1. Temporarily tighten all bolts.
 2. Align the subframe.
 3. Torque all bolts as shown below.

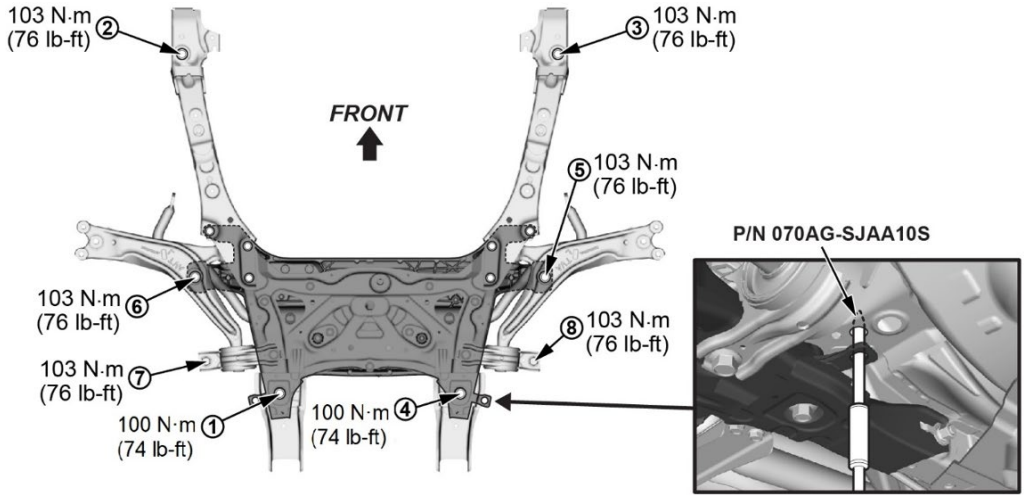

49. Disconnect the rear engine harness connector.

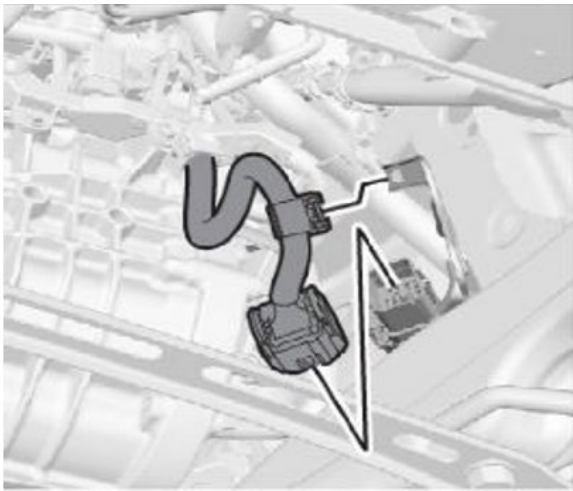

50. Raise the vehicle so the lift table can be positioned under the engine while having access to the engine mount nuts and bolts.



51. With the lift table supporting the engine, unbolt the side engine mount from the engine and the transmission mount.

A: Side Engine Mount

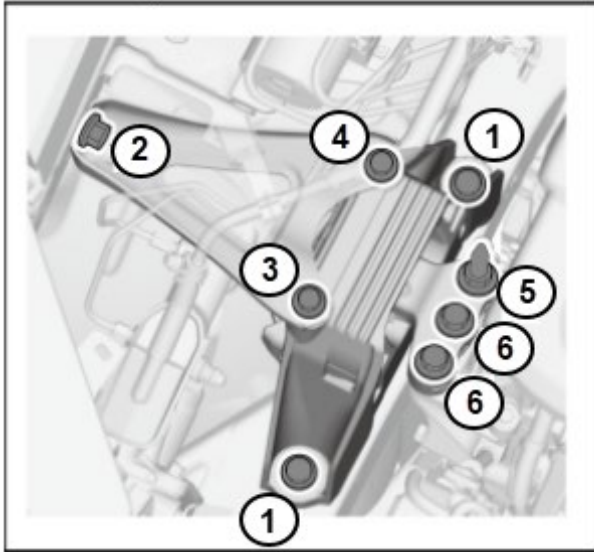

B: Transmission Mount

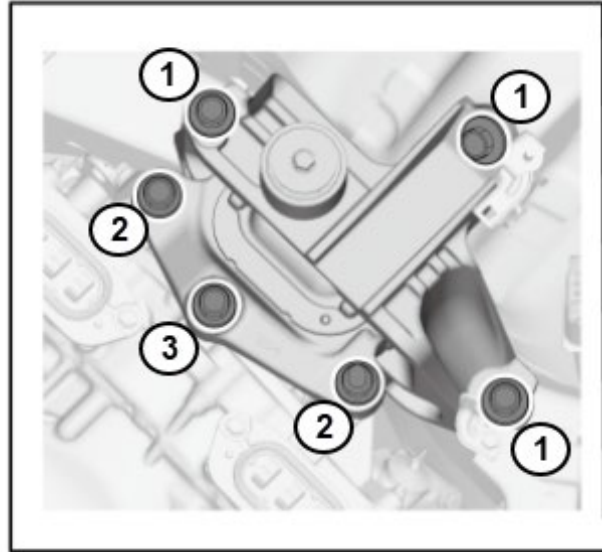

Tightening Torque

Mount No.	Mount Name	Mount Bolt/Nut Tightening Sequence					
		1	2	3	4	5	6
A	Side Engine Mount	55 N.m (41 lbf-ft)	55 N.m (41 lbf-ft)	55 N.m (41 lbf-ft)	55 N.m (41 lbf-ft)	100 N.m (74 lbf-ft)	100 N.m (74 lbf-ft)
B	Transmission Mount	75 N.m (55 lbf-ft)	55 N.m (41 lbf-ft)	55 N.m (41 lbf-ft)	—	—	—

52. Lift the vehicle high enough to move the lift table with the powertrain assembly.

53. Remove the engine wire harness.

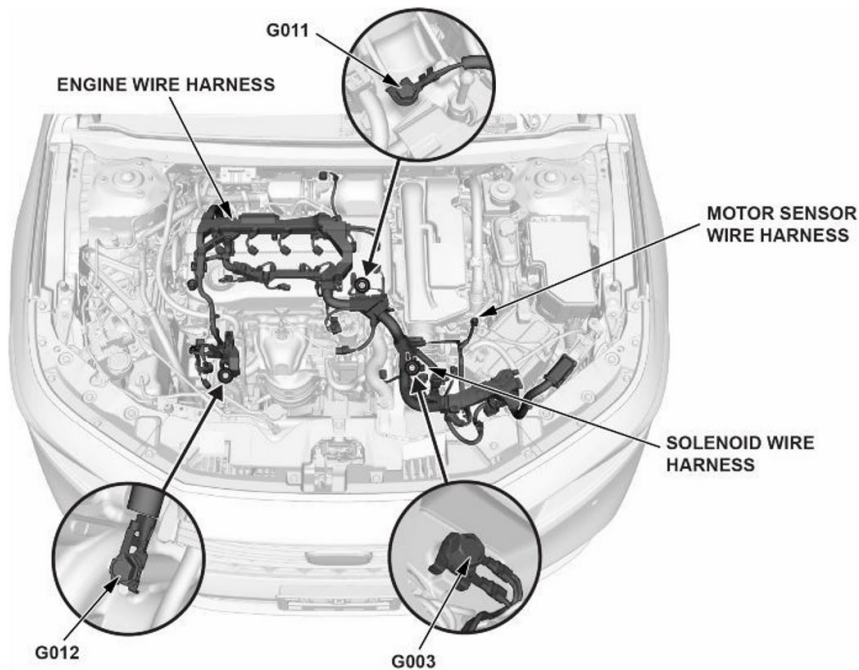

54. Disconnect the harness connections to the intake manifold and then remove the intake.

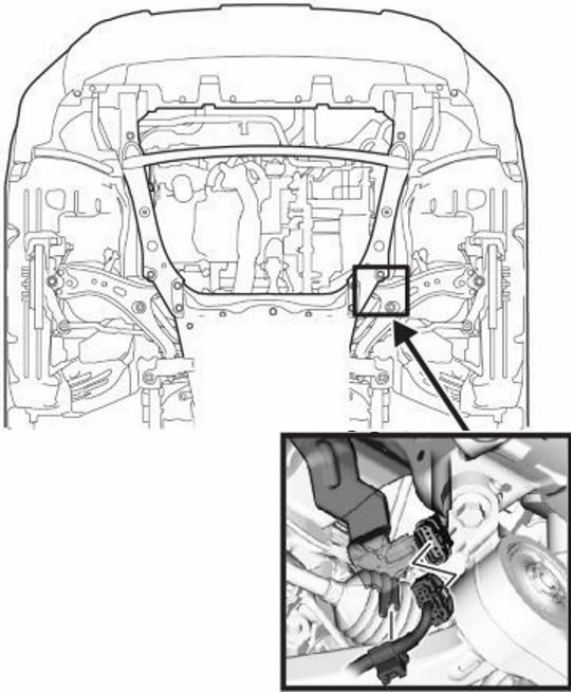

55. Remove EGR cooler and hoses.

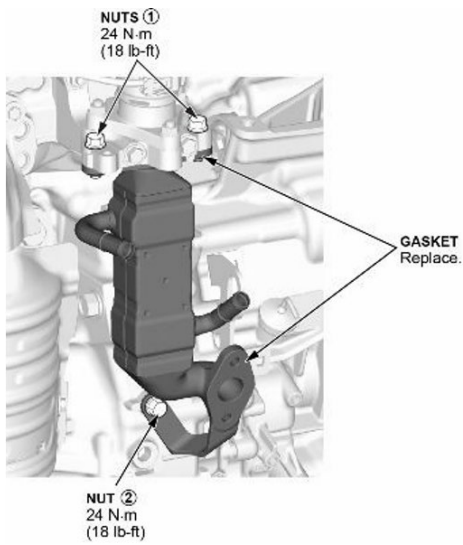

56. Remove the drain bolt, to drain the remaining coolant from the block.

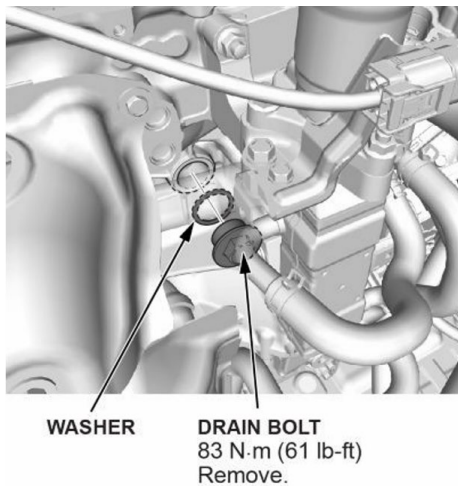

57. Remove the water passage housing.

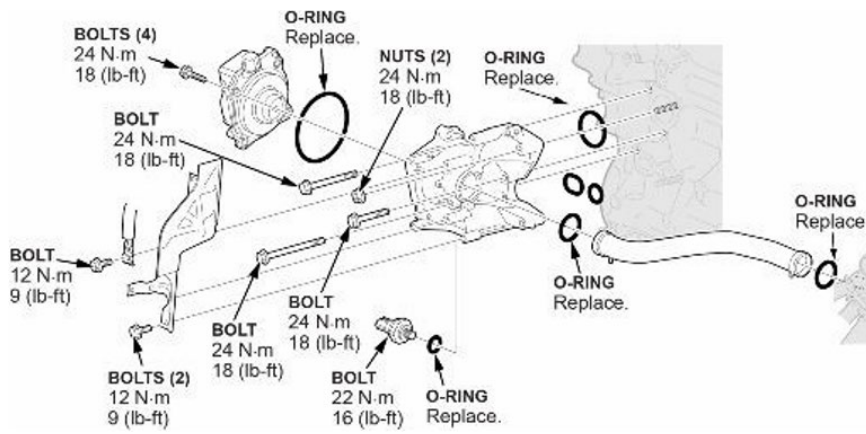

58. Remove the knock sensor.

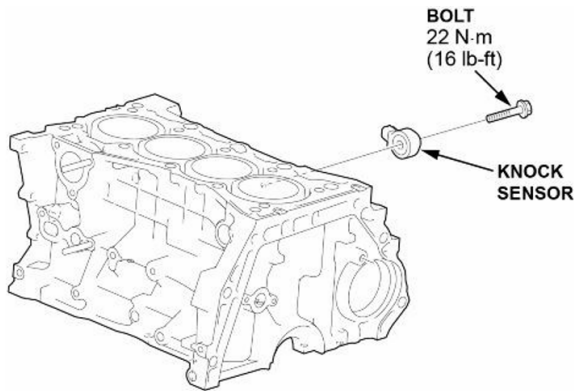

59. Remove the A/C compressor engine bracket.

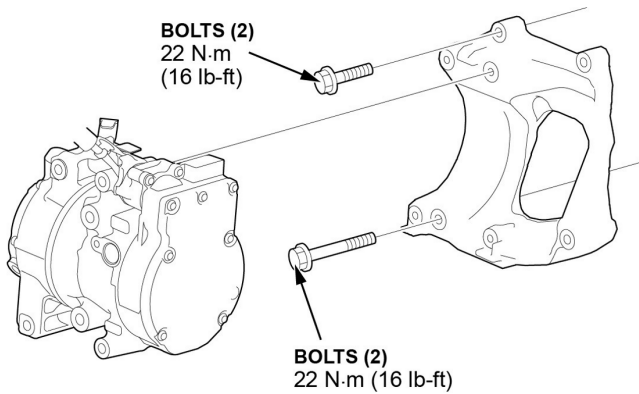

60. Remove the electric VTC motor.

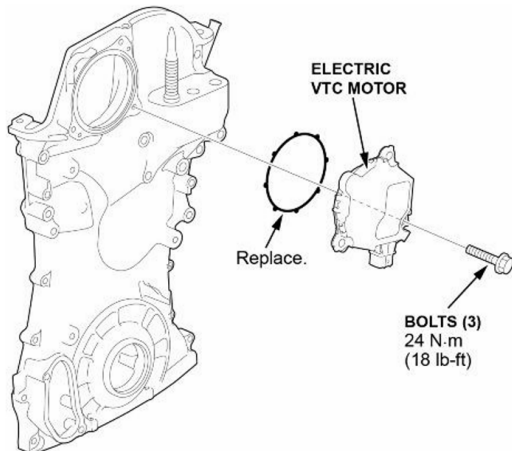

61. Remove the cylinder head cover.

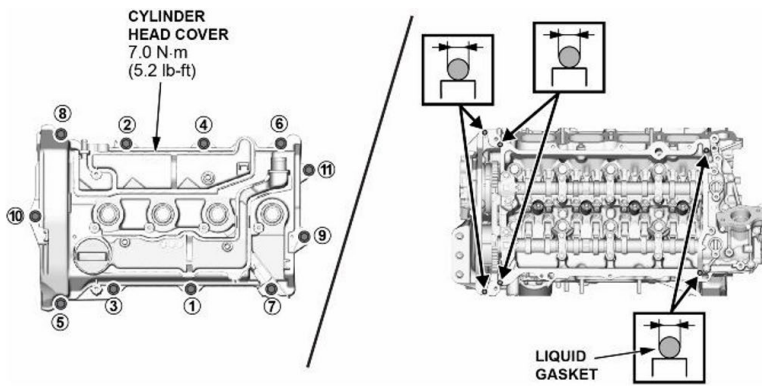

62. Remove the fuel Joint pipe.

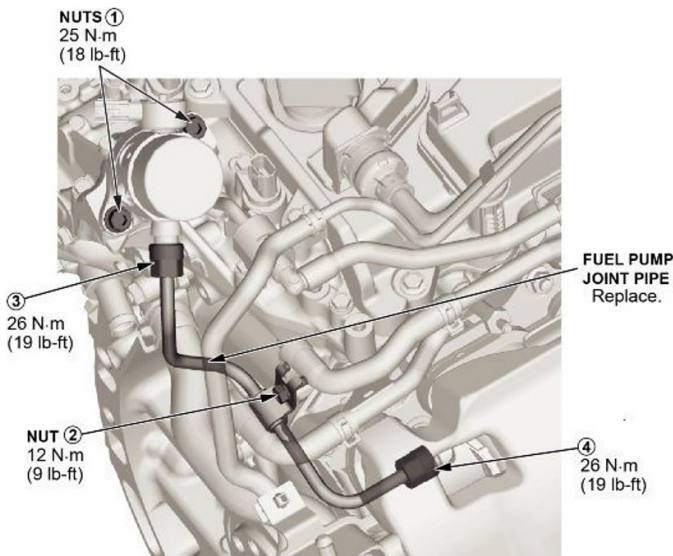

Step	Operation	Object	Detail
1	Hand Tighten	③, ④	The end of the joint pipe is seated on the fuel rail or high pressure fuel pump.
2	Loosely Install	②	Set the bracket to the cylinder head, and loosely install it.
3	Tighten	All bolts and nuts	① → ② → ③ → ④

63. Remove the high pressure fuel pump.

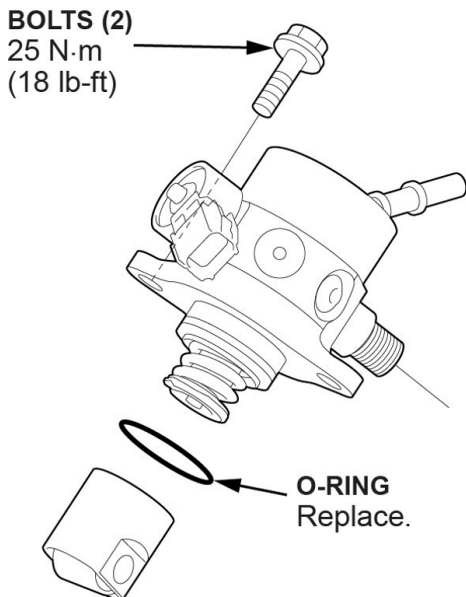

64. Remove the purge valve and bracket assembly bracket.

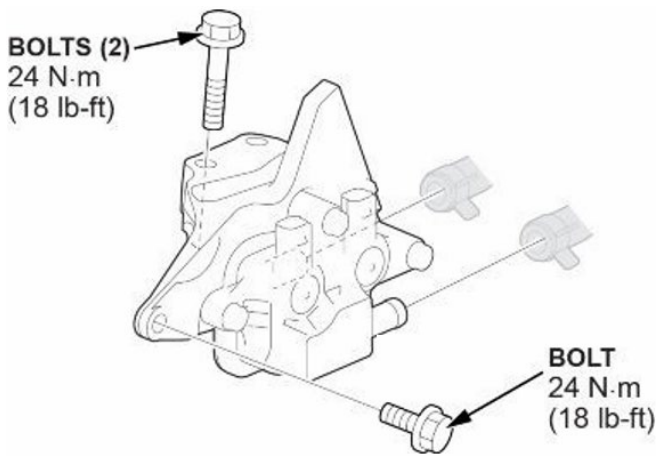

65. Remove the high pressure pump holder.

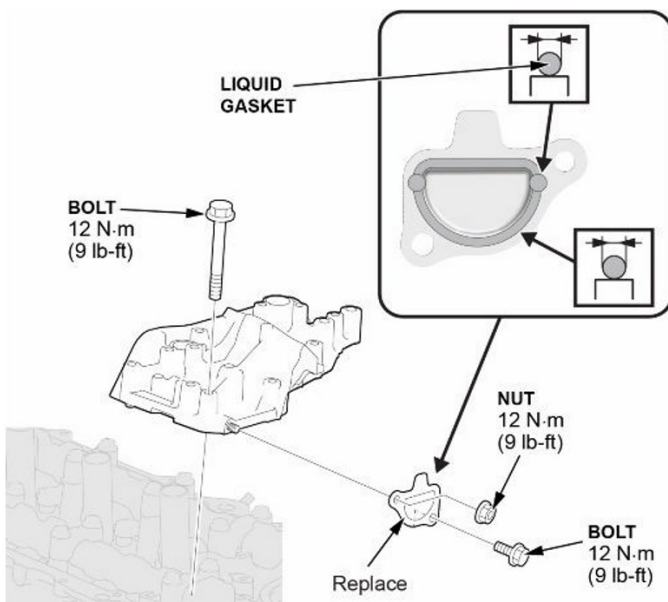

66. Remove the crankshaft pulley.

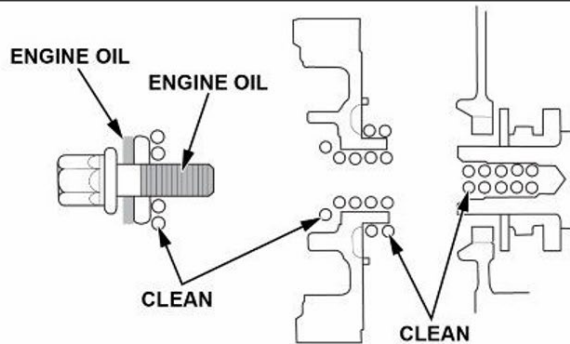
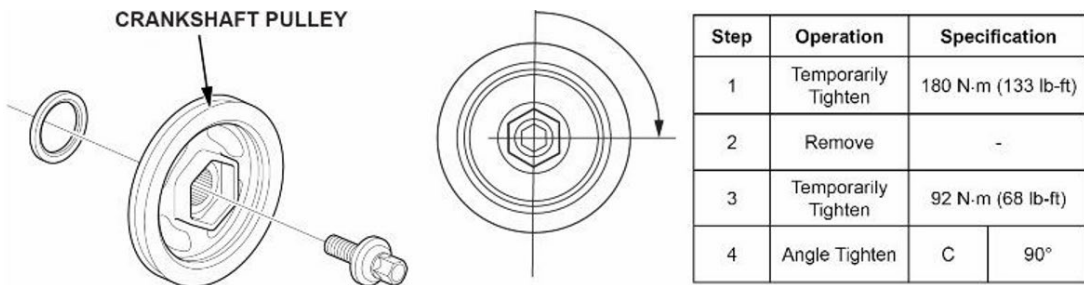

67. Remove the cam chain case cover.

NOTE: The oil seal must be replaced during re-installation; make sure the new oil seal is not distorted.

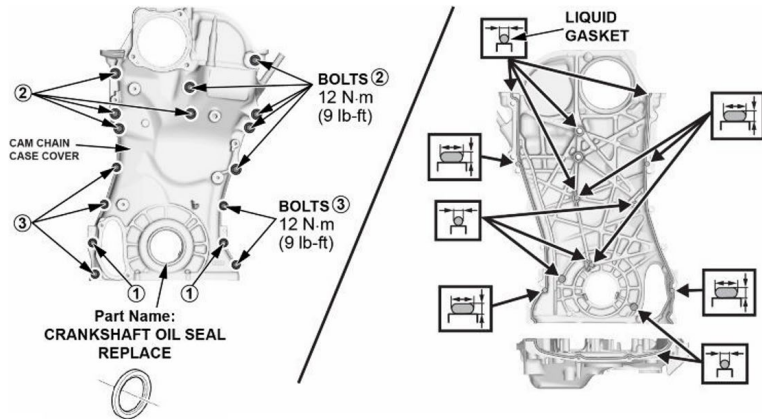

Lubricant Specifications (Figure 1)

Position	Type	Detail	
a	Liquid Gasket (P/N 08718-0003, 08718-0004, or 08718-0009)	b	2.5 mm (0.098 in.)
		c	3.5 mm (0.138 in.)
		d	11 mm (0.43 in.)

68. Remove the chain auto-tensioner.

1. Rotate the crankshaft counterclockwise to align the holes on the lock and the cam chain auto-tensioner.

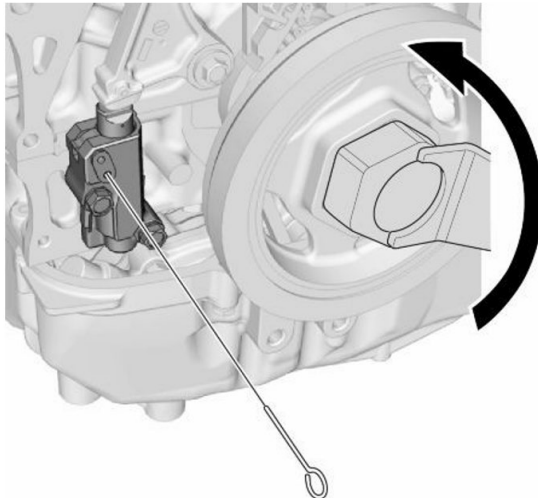

2. Insert a pin into the hole.

NOTE: If the holes in the lock and auto-tensioner do not align, continue to rotate the crankshaft counterclockwise until the holes align, then install the pin. Pin specifications **1.2 (3/32 in)**

3. Turn the crankshaft clockwise to secure the pin.

69. Remove the cam chain guides.

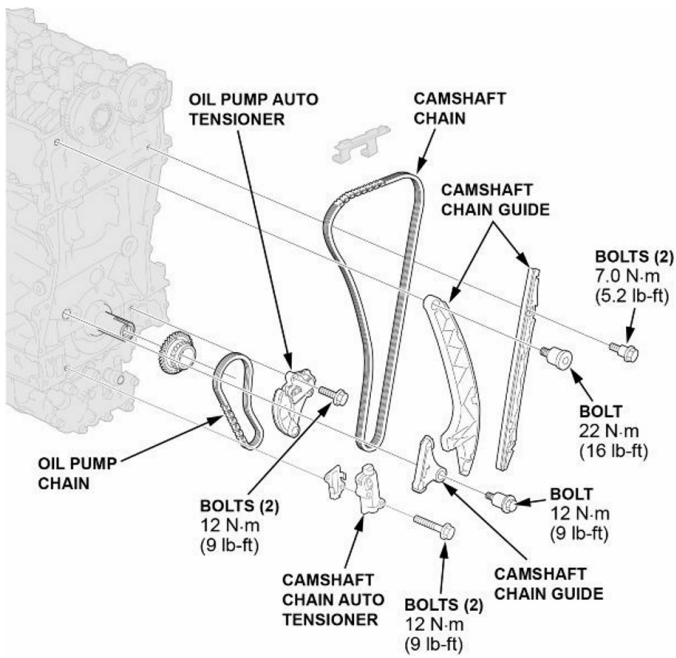

70. Remove the cam chain.

71. Remove the cylinder head bolts.

Tightening Procedure (when the new cylinder head bolt is installed)

Step	Operation	Object	Detail
1	Temporarily Tighten	All bolts	40 N-m (30 lb-ft)
2	Angle Tighten	All bolts	200°

Tightening Procedure (when the cylinder head bolt is reused)

Step	Operation	Object	Detail
1	Temporarily Tighten	All bolts	40 N-m (30 lb-ft)
2	Angle Tighten	All bolts	160°

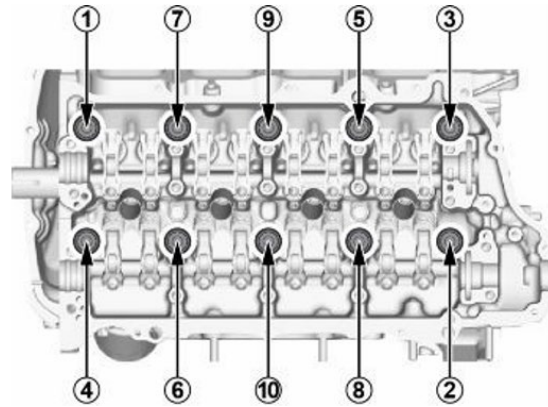

72. Measure the diameter of each cylinder head bolt.

NOTICE

If either diameter is below the specifications, replace the cylinder head bolt.

Position	
a	45 mm (1.77 in.)
b	50 mm (1.97 in.)

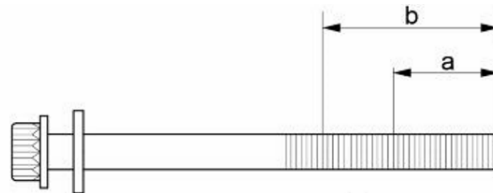

Service Limit	
Outer Diameter	10.6 mm (0.417 in.) min.

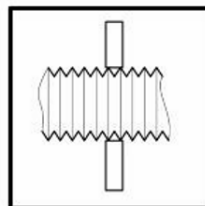

73. Remove cylinder head.

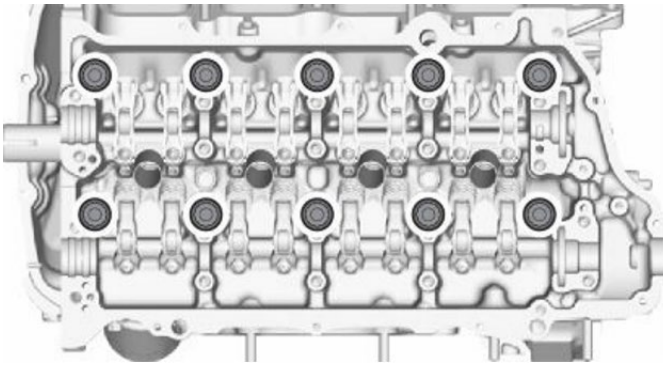

74. Remove transmission bolts and separate the transmission.

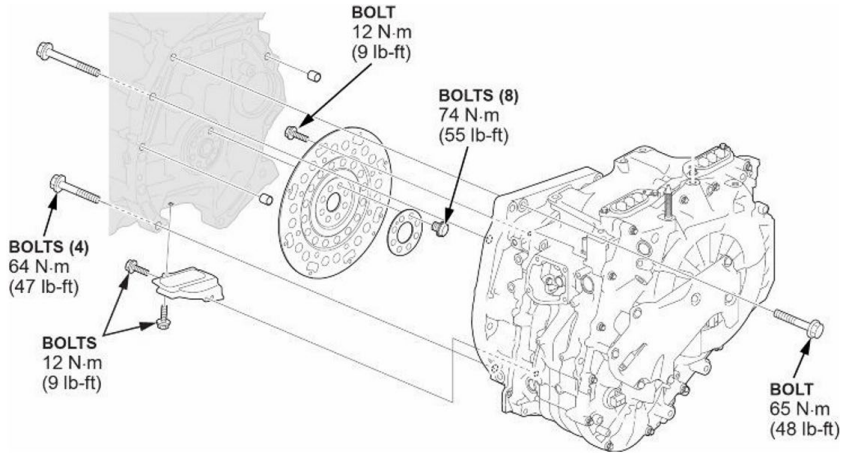

75. Remove the eight flex plate bolts. Rotate the crankshaft to access the flex plate bolts.

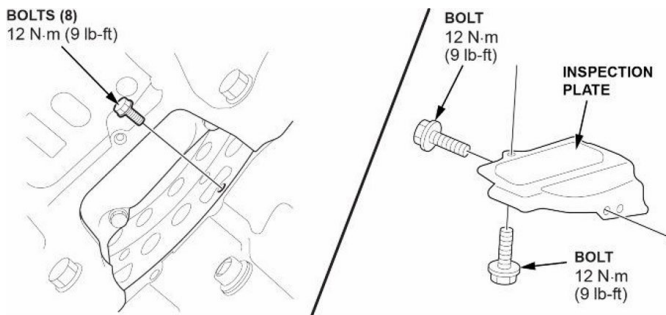

76. Remove the insulators.

NOTE: Replace all clips during installation. The insulator on the water pump will not be removed.

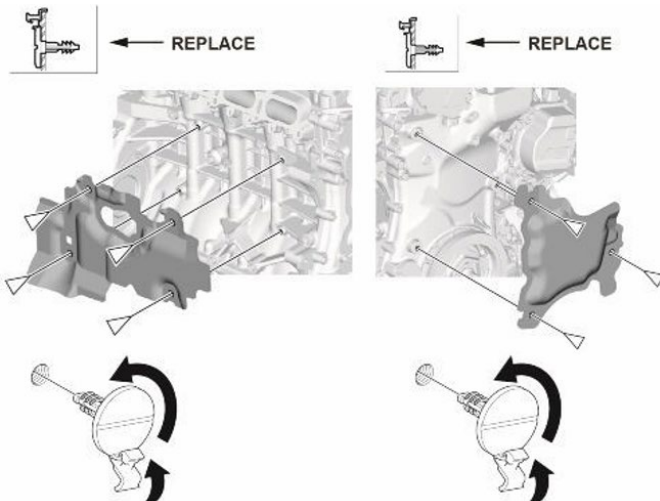

77. Install all parts in the reverse order of removal.
78. Do the PCM reset.
79. Do the CKP patten learn procedure.
80. Do the idle speed inspection.
81. Do the ignition timing inspection.
82. Check the wheel alignment.
83. VTC Position Learn Procedure.
 1. Connect the i-HDS.
 2. Select the following menu buttons on the HDS screen in sequence: Select PGM-FI, Adjust, E-VTC Learning.
 3. Turn the vehicle to the OFF (LOCK) mode.
 4. Jump the SCS line with the HDS.
 5. Wait 60 seconds, and exit the SCS mode with the HDS.
84. California residents only: Fill out a Vehicle Emissions Recall – Proof of Correction certificate, and use OEP as the recall number. Have the service advisor give the certificate to your customer, and advise him or her to keep it as proof that the recall was completed. Your customer will need to submit this certificate to the DMV only if the DMV requests it. If you need more certificates, use reorder number Y0657

Vehicle Emission Recall - Proof of Correction				
License Number	Make	Year Model	Body Type	Vehicle Identification Number <div style="border: 1px solid black; display: flex; justify-content: space-between; height: 20px; width: 100%;"></div>
Manufacturer _____			Recall Number OEP	
The above described vehicle has been repaired, modified and/or equipped with any emission control devices to meet applicable California Emission Control Laws.				
Dealer's Name _____		Address, City, State and Zip _____		
Date _____	Dealership's Authorized Signature _____			
<input checked="" type="checkbox"/> X				
Return this certificate to DMV only when required - otherwise retain for your records.				

Y0657
ACL 24832 (0212)