

## Quality Bulletin

TITLE:

**Complementary CP1074: Polestar 3 VCU2 Upgrade  
Model Year 2025 Polestar 3**

<b>GROUP:</b> 71	<b>NO:</b> CP1074	<b>ISSUING DEPARTMENT:</b> Product, Safety and Compliance	<b>CAR MARKET:</b> United States and Canada	
<b>REVISIONS:</b>			<b>ISSUE DATE:</b> 2026-02-13	<b>STATUS DATE:</b> 2026-02-13
<b>Page 1 of 17</b>				

### BULLETIN REFERENCE

- A. UPGRADE CP1074 DESCRIPTION
- B. VEHICLES INVOLVED
- C. PORT VEHICLES
- D. PARTS INFORMATION/PARTS RETURN
- E. OWNER NOTIFICATION
- F. VEHICLES IN INVENTORY
- G. SERVICE POINT RESPONSIBILITY
- H. TECHNICIAN COMPETENCY REQUIREMENT
- I. REIMBURSEMENT PROCEDURES & ALLOWANCE
- J. CORRECTIVE ACTIONS

#### A. UPGRADE CP1074 DESCRIPTION

In order to prepare for future functional growth Polestar 3 cars will be upgraded with an improved core computer.

Polestar has decided that all cars, concerned by this field service action shall be upgraded in accordance with this action at the next workshop visit or prior to customer delivery.

#### WHAT SHOULD YOUR CUSTOMERS DO NOW?

Install any available OTA software updates prior to the workshop visit as this can simplify the upgrade process.

Average consumption data will show incorrect after the upgrade, it will correct after the next charging cycle.

# Quality Bulletin CP1074

## B. VEHICLES INVOLVED

**NOTE: SERVICE POINT MUST CONFIRM VEHICLE ELIGIBILITY PRIOR TO BEGINNING THIS UPGRADE.**

Vehicle eligibility must be confirmed with VIDA, see SMB00-033P for instructions.

All vehicles must be checked for any incomplete Recalls, Service Campaigns, or Service Upgrades. All open Recall, Service Campaigns or Service Action repairs must be completed.

## C. PORT VEHICLES

NOT all eligible vehicles arriving from the ports will have this upgrade completed. Vehicle eligibility must be confirmed as outlined in Step B. above.

## D. PARTS / PARTS RETURN

Parts should be returned according to normal process for exchange parts. Please refer to parts bulletin for automatic delivery information of VCU2. The bracket is not restricted and can be ordered as needed.

Part	Part Description	Qty	Models
36013403	Control Unit, Exch (VCU)	1	Polestar 3
32375652	Bracket LHD (VCU)	1	Polestar 3
32471270	Read Data VCU APPL	1	Polestar 3
32301992	Total Upgrade	1-2 as needed	Polestar 3
32464024	VCU Retrofit	1	Polestar 3

## E. OWNER NOTIFICATION

An owner's notification will be sent out that will notify the owner of this complementary program at a later date.

## F. VEHICLES IN INVENTORY

In order to provide the best new car handover experience, vehicles should be upgraded with CP1074 before new car handover.

## G. SERVICE POINT RESPONSIBILITY

All vehicles qualifying for this complementary program should be upgraded at the next service opportunity.

## H. TECHNICIAN COMPETENCY REQUIREMENT

The technician's competency requirement for this upgrade is "Polestar Quality".

# Quality Bulletin CP1074

## I. REIMBURSEMENT PROCEDURES & ALLOWANCE

Upgrade CP1074 claims should be submitted using the LONG FORM application only.

**Claim Type:** CP1074  
**Cause Code:** 02  
**CSC Code:** XW  
**Main OP:** 97593-2  
**Failed Part No:** 36013403 Control Unit, Exch (VCU)

<u>Operation Number</u>	<u>Repair Description</u>	<u>Qty</u>	<u>Models</u>	<u>Labor Time</u>
97593-2	Vehicle computational unit VCU replace acc. to QB	1	Polestar 3	1.8
99943-3	Software downloading acc. to QB (first total if software older than 1.4.12)	1	Polestar 3	0.2
97594-3	Calibration with VIDA acc. to QB (For cars without air suspension)	1	Polestar 3	0.1

Part	Part Description	Qty	Models
36013403	Control Unit, Exch (VCU)	1	Polestar 3
32375652	Bracket LHD (VCU)	1	Polestar 3
32471270	Read Data VCU APPL	1	Polestar 3
32301992	Total Upgrade	1-2 as needed	Polestar 3
32464024	VCU Retrofit	1	Polestar 3

**\*Labor times provided are current at the time of release and are subject to change: Claims will be paid at the time in effect on the repair date.**

Second total upgrade and 99943-3 may be claimed only if the vehicle arrives at workshop below 1.4.12.

## J. CORRECTIVE ACTIONS

If the vehicle has any active QBs associated with it, complete those QB actions first to ensure a fully functional vehicle.

The vehicle needs to have SW baseline 1.4.12 or later prior to the upgrade. There may be a small update available if the vehicle is on 1.4.12. It is not necessary to perform that upgrade.

**NOTE! It's very important that the procedure in the instruction is followed properly. Do not perform additional total upgrades beyond those listed in the instructions.**



<b>Title</b>	Vehicle Computational Unit (VCU)	<b>Page</b>	1 ( 14 )
<b>Action</b>	Replacement	<b>Operation number:</b>	

<b>Issue</b>	<b>Date</b>	<b>Reason</b>
1	2025-12	First issue

**Affected vehicles**

<b>Model year</b>	<b>Model</b>
2025	Polestar 3

**Special tools**

<b>Description</b>	<b>Part No.</b>
Plug kit in bag	951 2578

If the vehicle has any active QB recalls associated with it, complete those QB actions first to ensure a fully functional vehicle.

The car needs to have SW baseline 1.4.12 or later prior to the upgrade. If that is not the case a total upgrade needs to be performed prior to step 1(can be done over-the-air), do not load any software before this.

**NOTE! It's very important that the procedure in the instruction is followed properly.**

### Color symbols

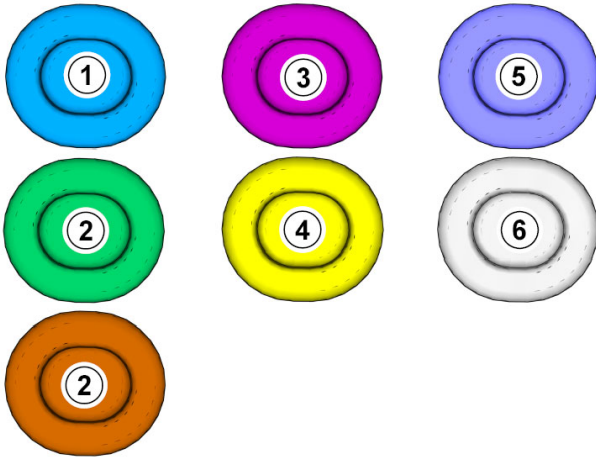

**Note! This colour chart displays (in colour print and electronic version) the importance of the different colours used in the images of the method steps.**

- 1 . Used for focused component, the component with which you will do something.
- 2 . Used as extra colors when you need to show or differentiate additional parts.
- 3 . Used for attachments that are to be removed/installed. May be screws, clips, connectors, etc.
- 4 . Used when the component is not fully removed from the vehicle but only hung to the side.
- 5 . Used for standard tools and special tools.
- 6 . Used as background color for vehicle components.

### Removal

**Note! The same PC must be used through the entire process.**

Check and note: Odometer, Service interval (time and distance).

Connect the car to VIDA, perform a readout and check network topology and make sure ECUs are responding.

SP: 32471270 Read data VCU

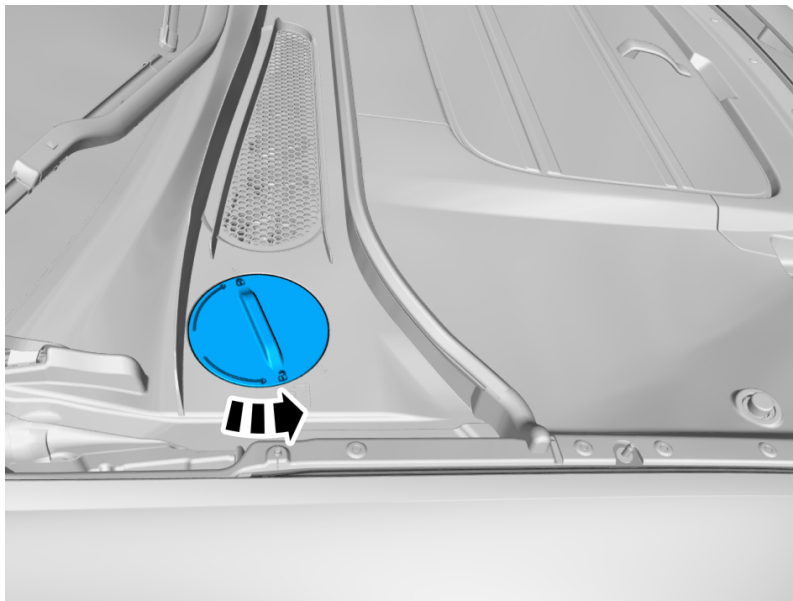

Remove the marked part.

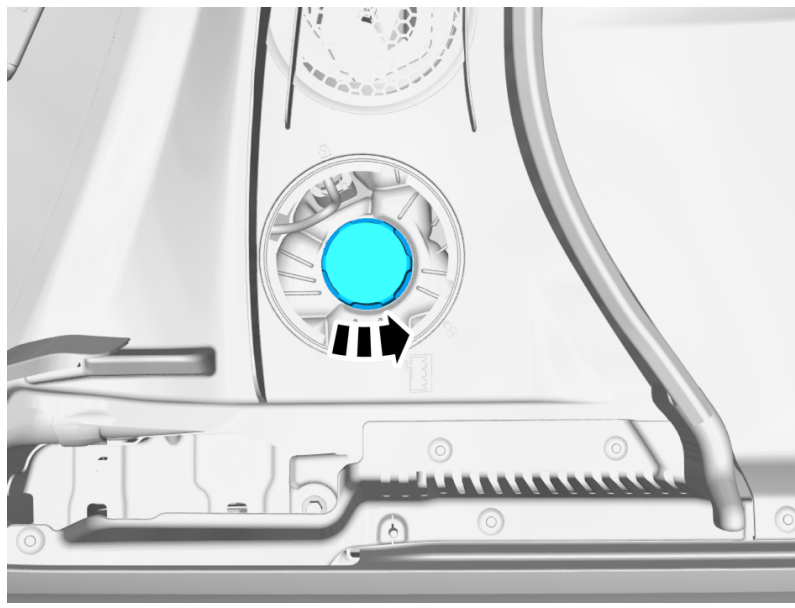

**Warning!** When releasing the cooling system pressure, cover the coolant expansion tank cap with a thick cloth.

Remove the marked part.

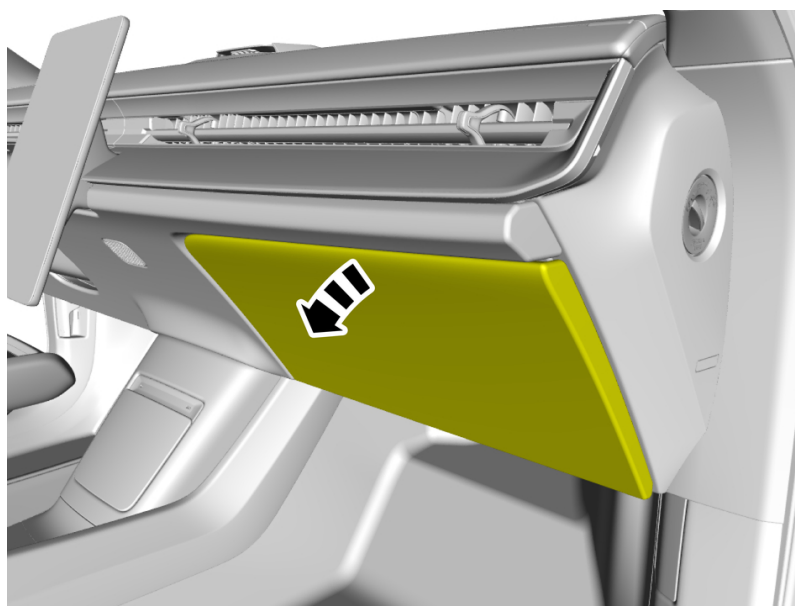

Follow the instructions regarding battery disconnecting and connecting , refer to:  
Cleaning, Inspection and Adjustment  
3 - Electrical system  
31 - Battery and mounting  
311 - battery

Disconnect the 12 volt battery.

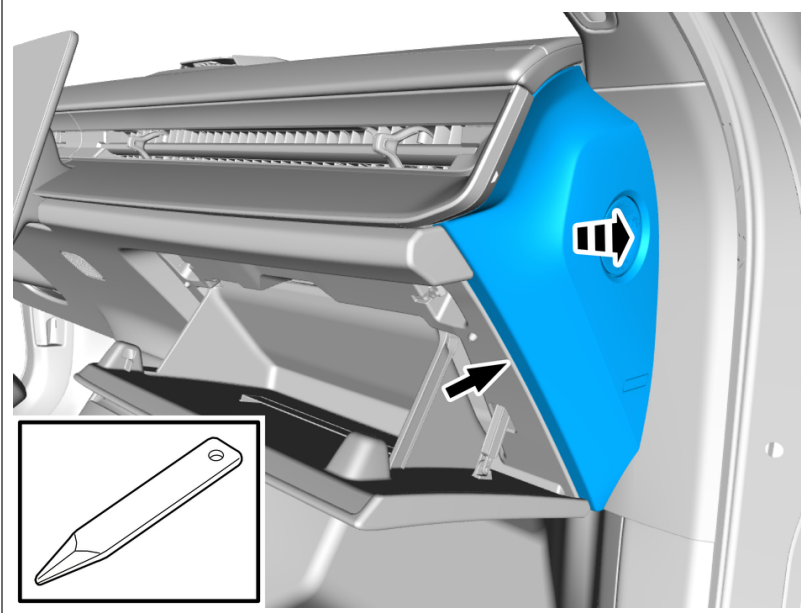

Remove the marked part.

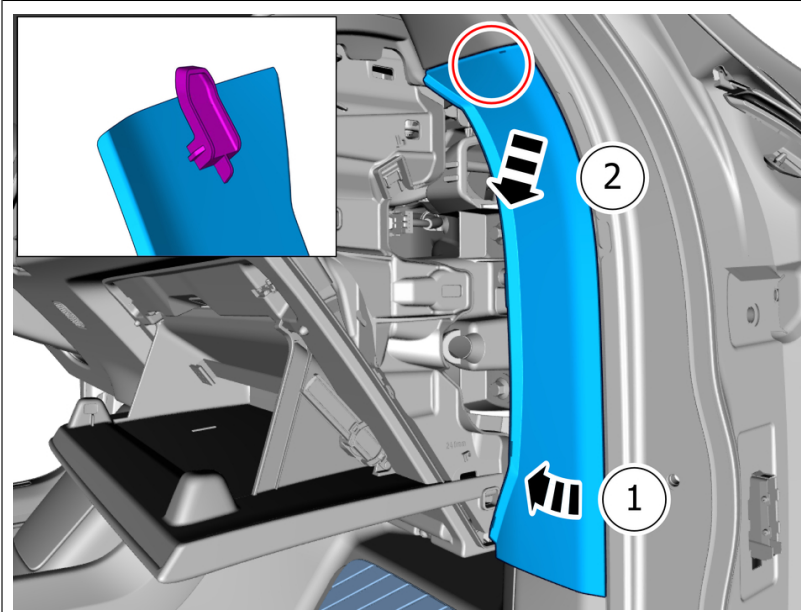

Remove the marked part.

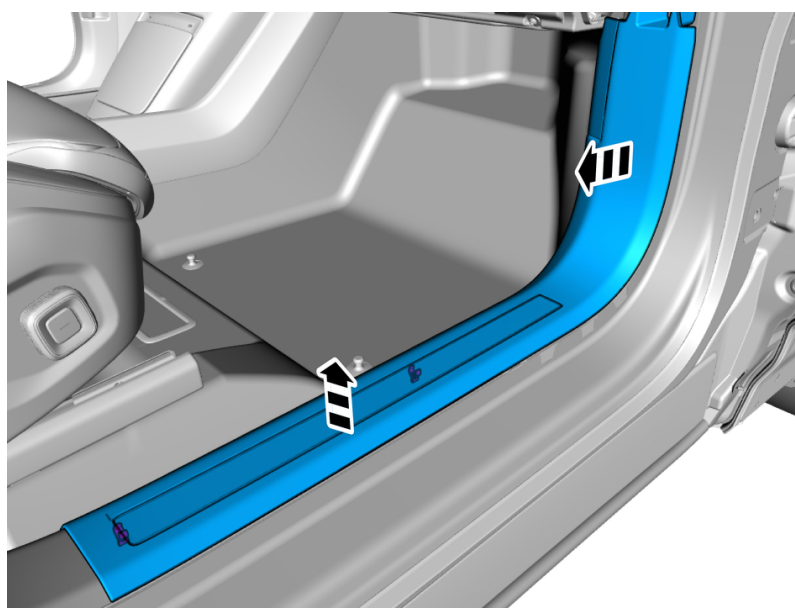

Remove the marked part.

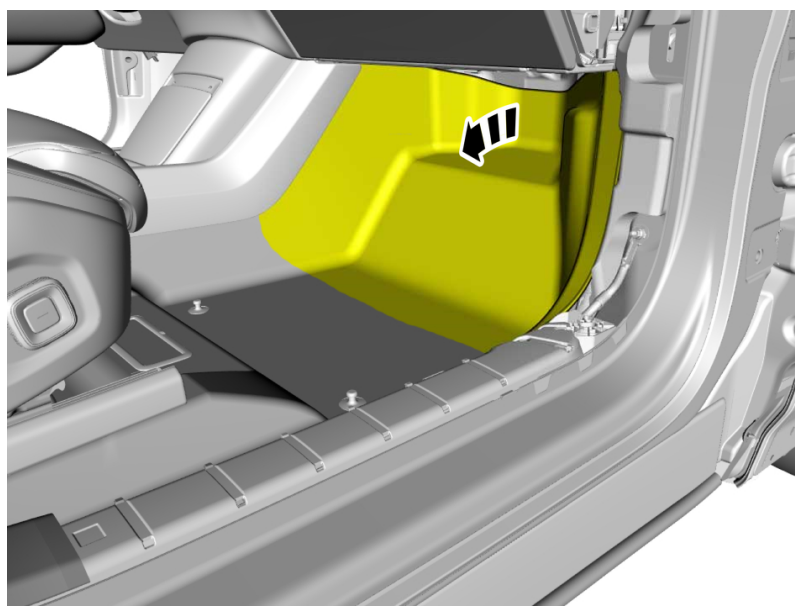

**Caution! Do not put the carpet back until the software is downloaded.**

Fold the carpet aside.

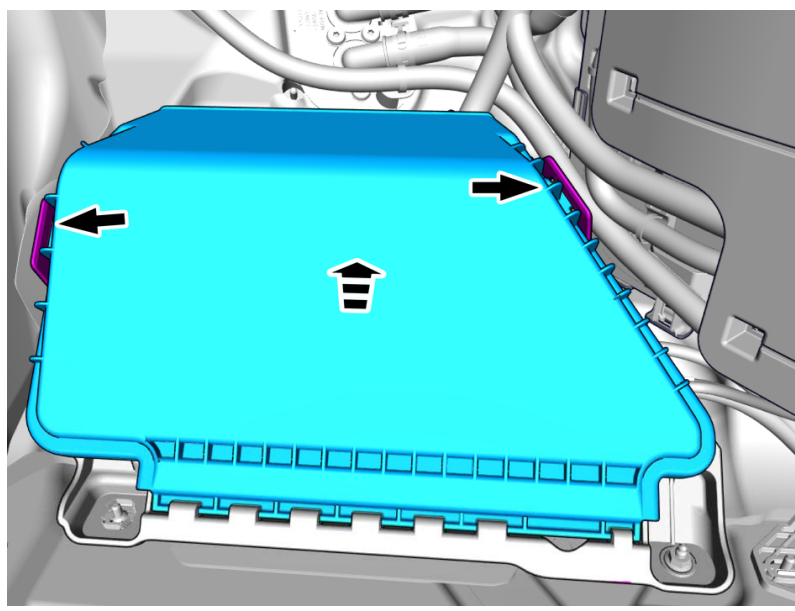

Release the locks.  
Remove the marked part.

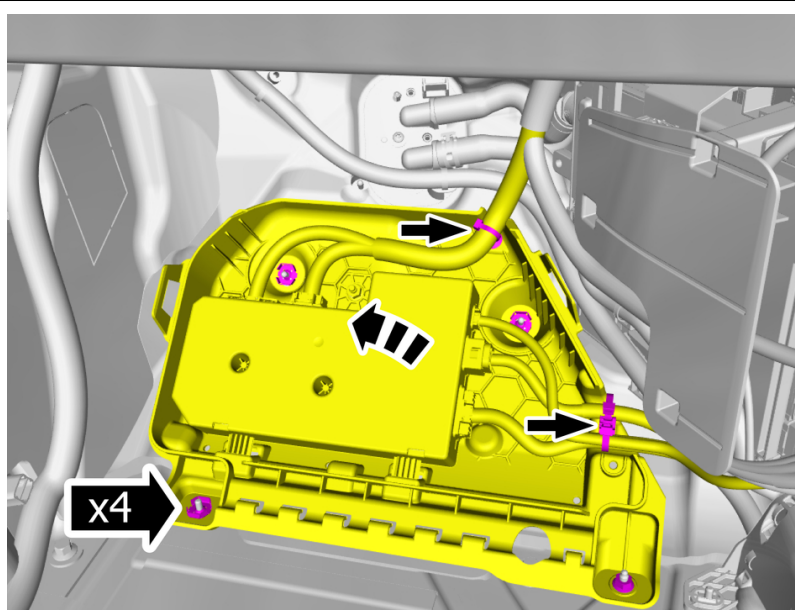

Remove the cable harness clips.  
Remove the nuts.  
Fold marked parts aside.

**Torque:**  
M6 , 10 Nm

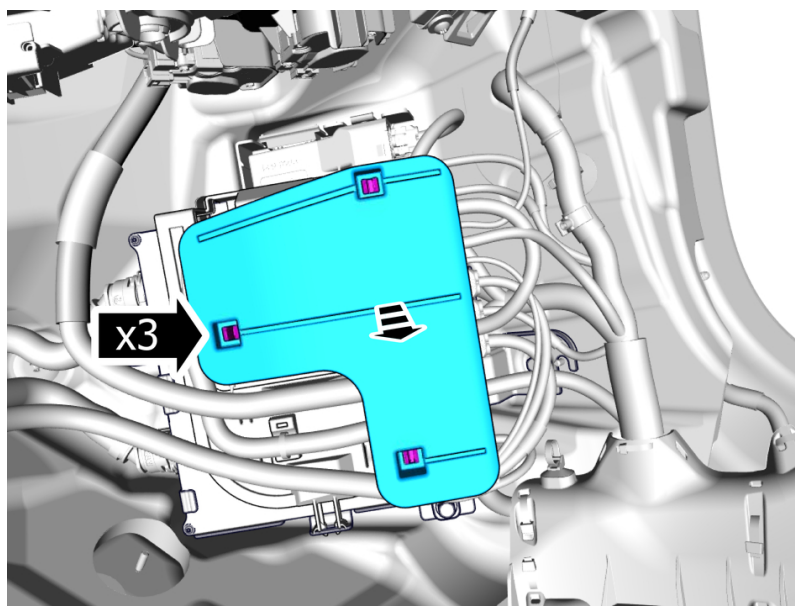

Depress the locking devices.  
Remove the marked part.

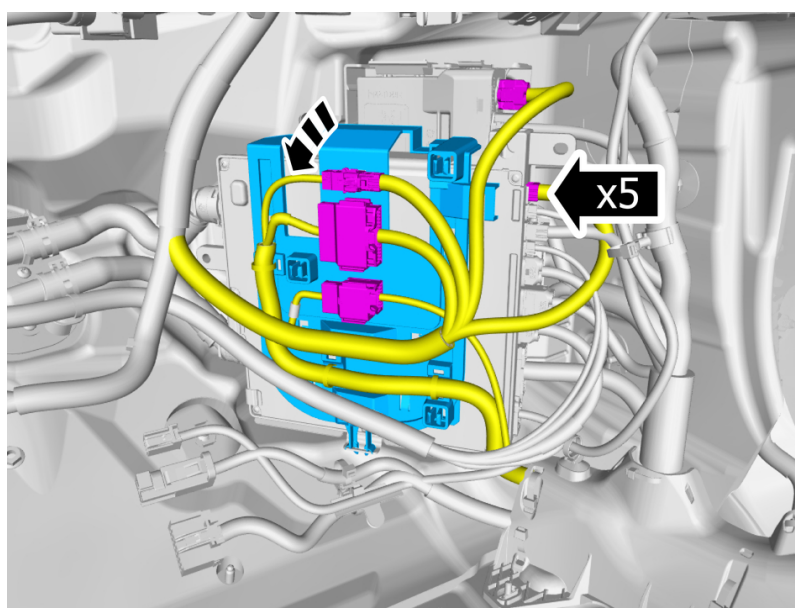

Disconnect the connectors.  
Fold the cable harness aside.

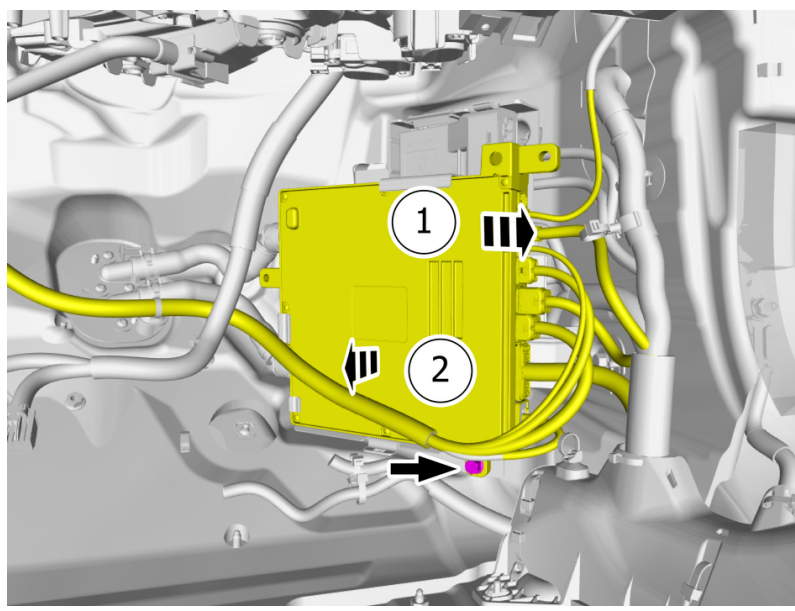

Remove the screw.  
Loosen the marked details.

**Torque:**  
M6 , 10 Nm

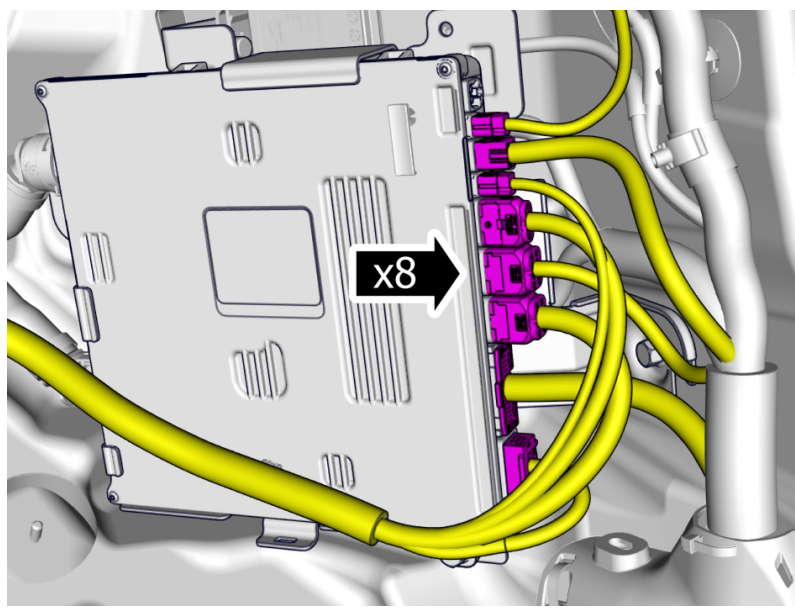

Disconnect the connectors.  
Fold marked parts aside.

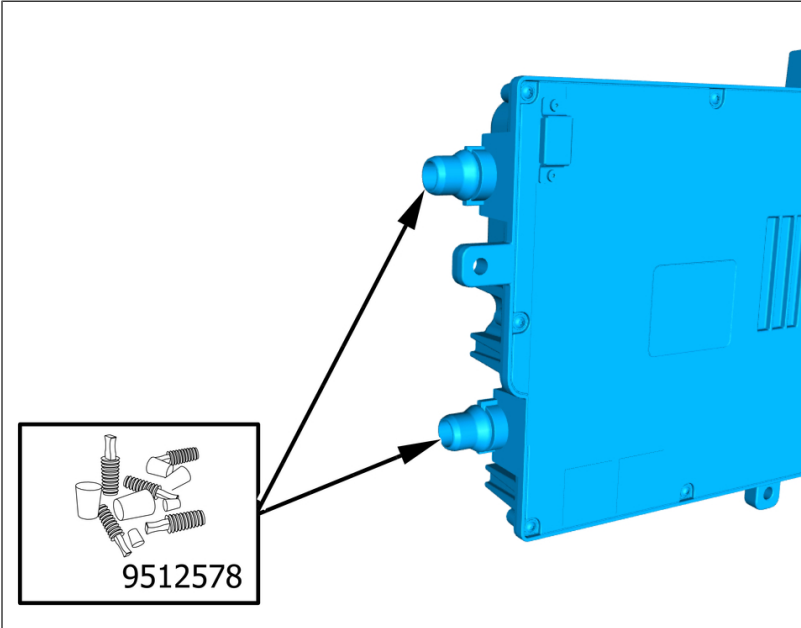

**Caution! Make sure to seal properly to avoid any leaks.**

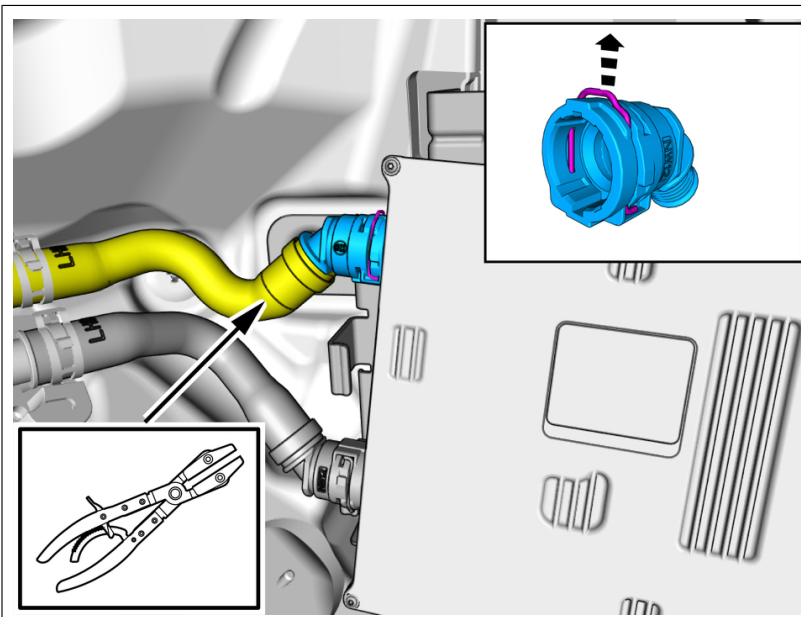

**Caution! Use suitable paper to absorb any escaping fluid.**

**Note! Tilt the unit to minimize leakage.**

Undo the hose from the connection.  
Allow the tool to remain.

Special Tool: T9512578, Plug kit in bag

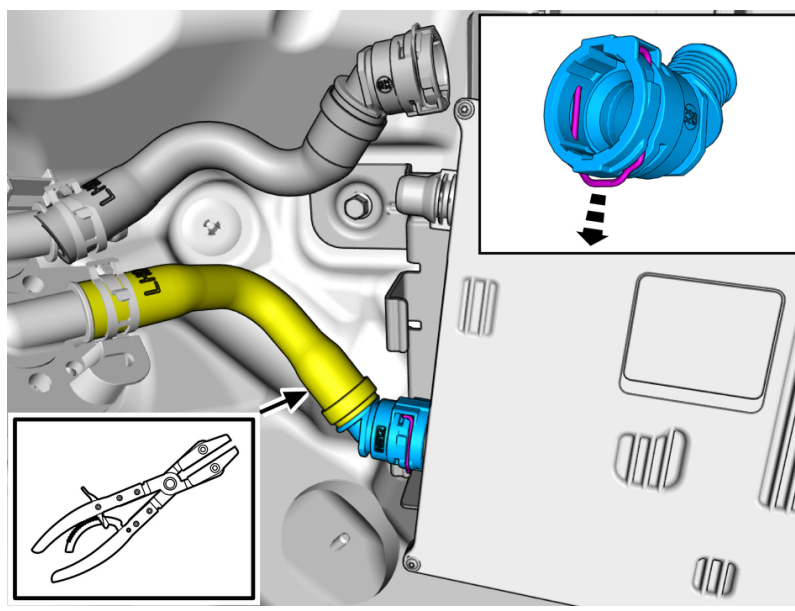

**Caution!** Use suitable paper to absorb any escaping fluid.

**Note!** Tilt the unit to minimize leakage.

Undo the hose from the connection.  
Allow the tool to remain.

Special Tool: T9512578, Plug kit in bag

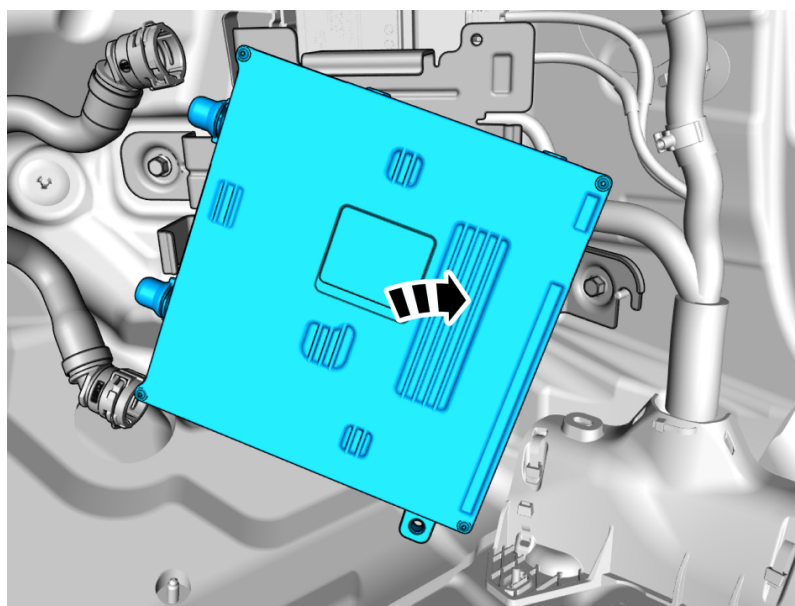

Remove the marked part.

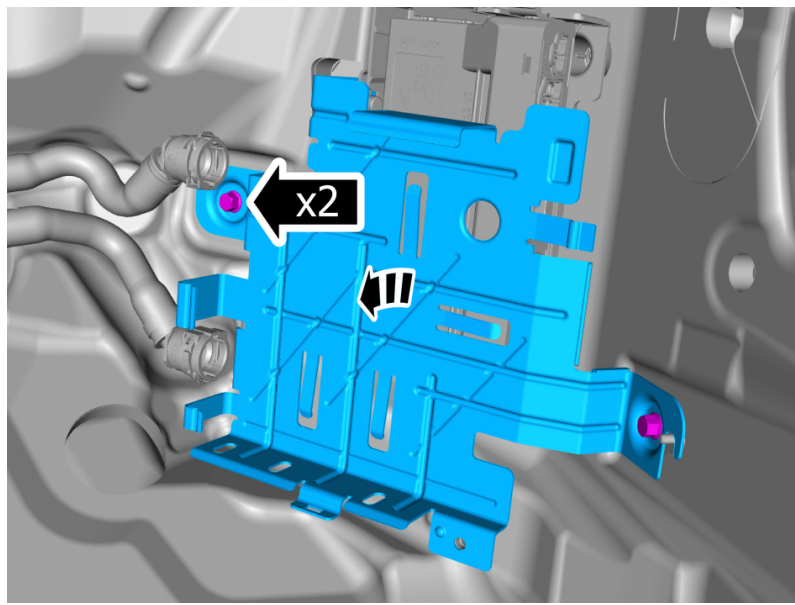

Remove the screws.  
Remove the marked part.

### Installation

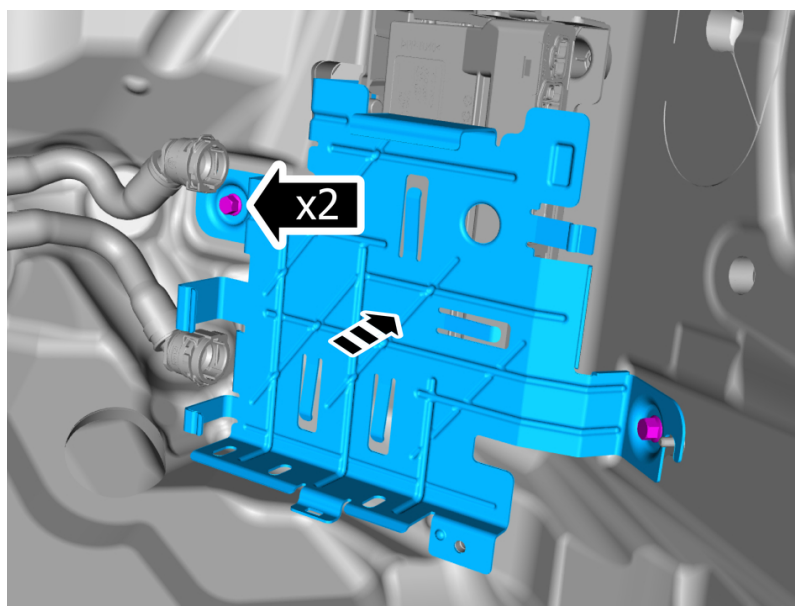

Install the marked component.  
Install the screws.

**Torque:**

M6 , 10 Nm

To install, reverse the removal procedure.

Follow the instructions regarding battery disconnecting and connecting , refer to:  
Cleaning, Inspection and Adjustment  
3 - Electrical system  
31 - Battery and mounting  
311 - battery

Connect the 12 V battery and connect the charger.

Connect the vehicle, enter the VIN manually, and do a readout.

If "Firewall cannot be unlocked" message is displayed, press "Continue".

SP: 32464024 VCU Retrofit

Check network topology and make sure ECUs are responding.

SP: 32301992 Total upgrade

Perform cooling system, electric powertrain, filling, and bleeding , refer to:  
Cleaning, Inspection and Adjustment  
2 - Engine with mountings and equipment  
26 - Cooling system  
261 - radiator and connections

Perform insulation test according to: Planning and Diagnostics / Diagnostics / Components / ECUs / High-Voltage Battery Module (HVBM) / Diagnostic Sequences / Insulation self-test for the high-voltage system

Vehicles without air suspension

Calibrate according to: Planning and Diagnostics / Diagnostics / Components / ECUs / High-Performance CPU A (HPA) / Diagnostic Sequences / Calibration of the position sensors, wheel suspension

Follow the instructions regarding headlamps, adjusting , refer to:  
Cleaning, Inspection and Adjustment  
3 - Electrical system  
35 - Lighting  
352 - lighting, front

All vehicles

Check and compare: Odometer, Service interval (time and distance).

If there are remaining camera calibration issues after the replacement is done, please contact technical helpdesk.