



# WORK INSTRUCTIONS MODEL Z FIFTH WHEEL (ALL EXCEPT Z3610) SIDEWALL REPLACEMENT

|                     |  |                    |              |
|---------------------|--|--------------------|--------------|
| <b>W.I. NUMBER:</b> | WI-029-2025 Model Z Sidewall Replacement |                    |              |
| <b>PRODUCT:</b>     | Model Z Fifth Wheel (All except Z3610)   | <b>REVISION:</b>   | REV-F        |
| <b>DATE:</b>        | February 17, 2026                        | <b>LABOR RATE:</b> | Per Contract |

**Applies to:**

This document refers to Brinkley Model Z Fifth Wheel Trailers with bedroom slide-outs except Z3610. Refer to Model G Sidewall Replacement Instructions for Z3610 repairs.

**Condition:**

Brinkley RV has determined that under certain conditions, minor cracks may form in the sidewalls, typically originating at the lower corners of a slideout opening.

**Correction:**

Brinkley RV has established a procedure to replace the sidewall, while providing additional support to minimize the possibility of future cracks.

**Table of Contents**

|  |    |
|--|----|
| Bedroom Slide-Out Removal Prep w/Wardrobe and Lav (Z2900 and Z3110)..... | 4  |
| Bedroom Slide-Out Removal Prep w/ Bed (All others except 3610).....      | 7  |
| Removing Bedroom Slide-out from RV.....                                  | 13 |
| Front Cap Removal.....   | 25 |
| Sidewall Fiberglass Skin Removal.....                                    | 26 |
| Sidewall Structure Modifications.....                                    | 34 |
| Fiberglass Wall Installation.....  | 42 |
| Reassembly and Prep for Paint.....                                       | 52 |
| Wall Structure Diagrams.....   | 58 |
| Additional Vendor Technical Information.....                             | 62 |

**⚠ WARNING**

**WARNING!** Because of the nature of this repair, use of ladders and other climbing and power equipment is required. Follow all ladder safety instructions posted on ladders and all equipment. It is required that professional technicians perform the repair, and a team of at least 4 - 5 people be used for certain parts of this procedure. Failure to do so could result in injury or death.

**⚠ WARNING**

**WARNING!** Turn off all electrical power to the RV PRIOR to beginning repairs. Be certain the RV is unplugged from shore power and the batteries are disconnected PRIOR to beginning welding. Failure to do so could result in property damage and injury or death.

**In addition to standard shop tools, the following specialized tools are required:**

1. Tape measure
2. Chalk line
3. Screw gun
4. #2 Square drive bit (various lengths)
5. Circular saw
6. Jig saw
7. Shop dolly



8. Pneumatic (air) saw
9. Flat bar
10. Pry bars
11. Razor knife
12. Pneumatic caulk gun
13. 3/8" bit
14. Oscillating multi-tool



15. 7/8" Hole saw
16. Pin router
17. Foam gun
18. Polystick



## PARTS INFORMATION

**NOTICE: To perform the following sidewall replacement, parts are pre-shipped to your dealership.** There are no kits specific to these repairs; instead, Brinkley has sent sufficient parts to repair a given number of units, regardless of model or floor plan.

The parts shipment will include the primary and secondary components for this repair including, but not limited to, sidewall skin, trim, baggage doors, graphics, fascia, etc. Other items will need to be supplied by your Service Shop, including, but not limited to, cleaners, clean rags, floor coverings, plywood (3/4" X 4' X 8'), lumber (2" X 4", 2" X 6", various lengths), eight (8) 1/4" X 2" X 2" angle, in 12' lengths (Figure 112, page 48) and miscellaneous shop supplies. Where applicable/possible, this document will call out the appropriate parts for each given step.

Your service team may also have procedures and equipment in place for some of the steps outlined in this document (removing a slide-out or front cap for example). Procedures and equipment outlined in this document are examples, and may deviate somewhat from your established processes and equipment.

Please review the parts received with the packing information to be sure you received everything on the list, in the appropriate quantities. **If there are discrepancies or shortages, please contact your Brinkley Parts Representative BEFORE commencing repairs.**

---

## WARRANTY INFORMATION

### ADVANCED CONTACT OR PRIOR AUTHORIZATION REQUIRED CLAIM REIMBURSEMENT PROCESSING:

All reimbursement requests with completed work orders, including any freight expenses and photographs, should be submitted via a claim in the Brinkley RV Dealer Portal.

### REQUIRED INFORMATION FOR IMMEDIATE REIMBURSEMENT PROCESSING INCLUDES:

1. The full 17 digit VIN;
2. The Retail Name if retail sold;
3. Dealer Name;
4. Dealer Address;
5. Dealer Phone Number;
6. Dealer Hourly Labor Rate;
7. Work Order detailing the work performed and labor time, and
8. Photographs of the repair; specifically:
  - Existing wall cracks **BEFORE** starting work
  - Aluminum wall sub-structure **BEFORE** repairs
  - Aluminum wall substructure **AFTER** repairs

**Reimbursement checks for claims submitted with all requested information are issued weekly.**



## SAFETY

This document provides general instructions. Many variables can change the circumstances of any procedure, i.e., the degree of difficulty involved in the service operation and the ability level of the individual performing the operation. This document cannot begin to plot out procedures for every possibility, but will provide the general instructions for effectively installing, removing or servicing the system. In the event the skill level required is too advanced or the procedure too difficult, a certified technician should be consulted before performing the necessary operation. Failure to correctly install, remove or service the system may result in voiding the warranty, inflicting injury or even causing death.

### **⚠ DANGER**

This indicates an imminent hazard that, if not avoided or handled correctly, will result in death or serious injury.

### **⚠ WARNING**

The “WARNING” symbol above is a sign that a procedure has a safety risk involved and may cause death, serious personal injury, severe product and/or property damage if not performed safely and within the parameters set forth in this document.

### **⚠ CAUTION**

The “CAUTION” symbol above is a sign that a procedure has a safety risk involved and may cause personal injury, product and/or property damage if not performed safely and within the parameters set forth in this document.

### **+ NOTICE**

This is used to address best practices that should be utilized and do not commonly result in injury but may lead to property damage if not careful.

### **⚠ DANGER**

**DANGER!** Removing the slide-out room must be performed in the following steps to make sure it is removed safely. Read this entire section carefully and familiarize yourself with the procedure before attempting to remove the slide-out room. If additional information is required, refer to the Lippert Slim-Rack manual (included with but separate from these instructions - QR code on the right). **Failure to follow these directions will result in death or serious injury.**



### **⚠ WARNING**

**WARNING!** Turn off all electrical power to the RV PRIOR to beginning repairs. Be certain the RV is unplugged from shore power and the batteries are disconnected PRIOR to beginning welding. Failure to do so could result in property damage and injury or death.

## BEDROOM SLIDE-OUT REMOVAL PREP (W/WARDROBE AND LAV - Z2900 - Z3110)

### + NOTICE

**NOTICE:** The FIRST slide-out section refers ONLY to Model Z2900 and Z3110 floor plans. These are the only Model Z floor plans with a wardrobe and lavatory sink in the slide-out. If NOT working with a Model Z2900 or Z3110 and the bedroom slide-out contains a bed, please proceed to page 7 to continue.

### WORK INSTRUCTIONS:

1. READ AND UNDERSTAND ALL INSTRUCTIONS PRIOR TO BEGINNING WORK.
2. Cover the bedroom floor in front of the slide-out with protective material to prevent floor covering damage.
3. Remove all personal items from the slide-out wardrobe and bath lav cabinet (Figure 1).

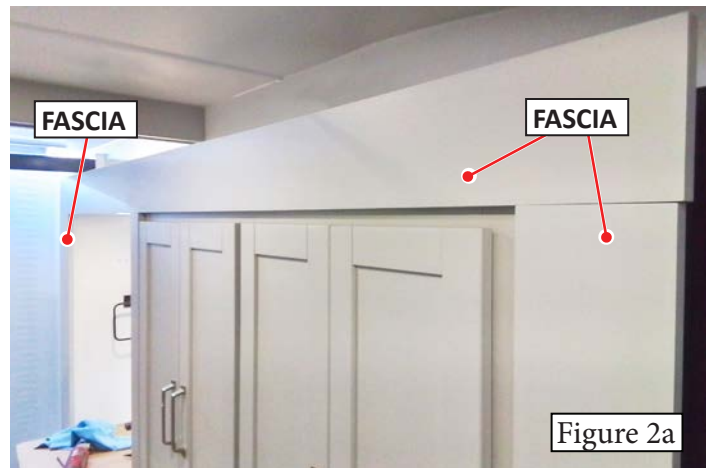
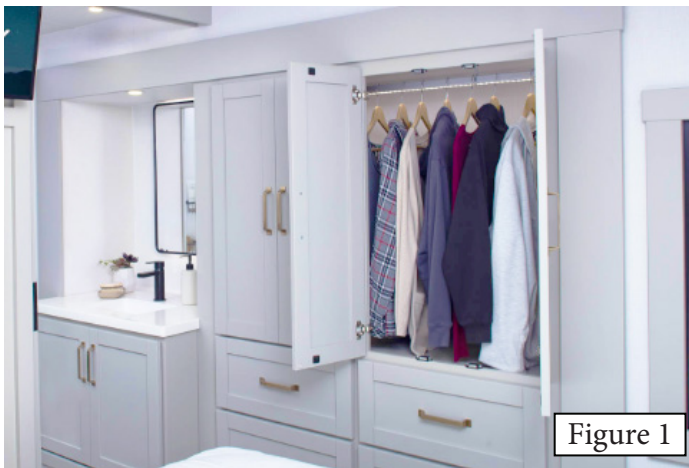

4. Extend the slide-out approximately half-way to allow access to the back side of the fascia (Figure 2a).
5. Use a screw gun with a #2 square drive bit to remove the screws on the back of the fascia boards (Figure 2b).
6. Use prying tools to remove the wood fascia boards from the metal fascia backer (Figure 2c). NOTE that there is adhesive in spots to help hold the fascia boards to the fascia backer.

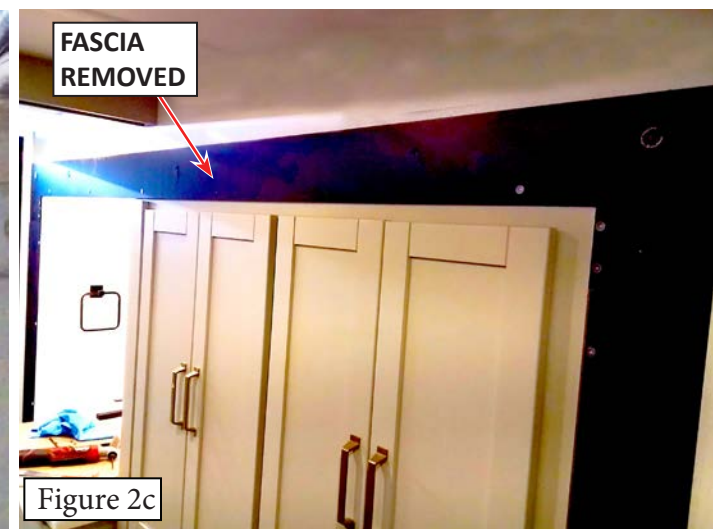
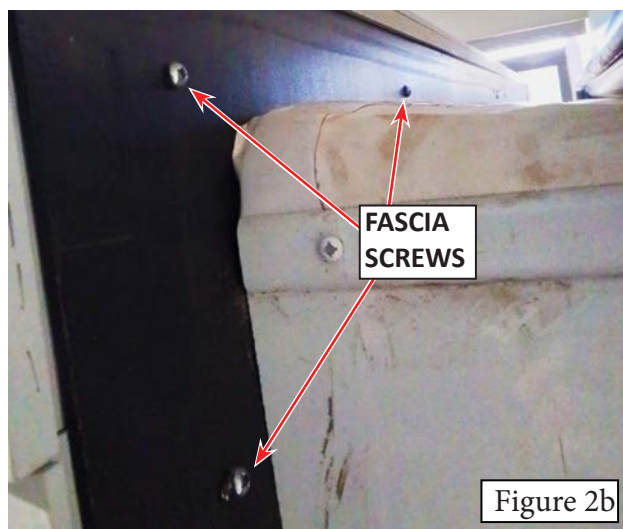

7. Use a screw gun and a #2 square drive bit to remove the fascia backer from the slide-out (Figure 3).
8. Access the plumbing, 12 VDC and 120 VAC electrical connections beneath the lav cabinet and wardrobe cabinets (Figure 4a, and 4b).

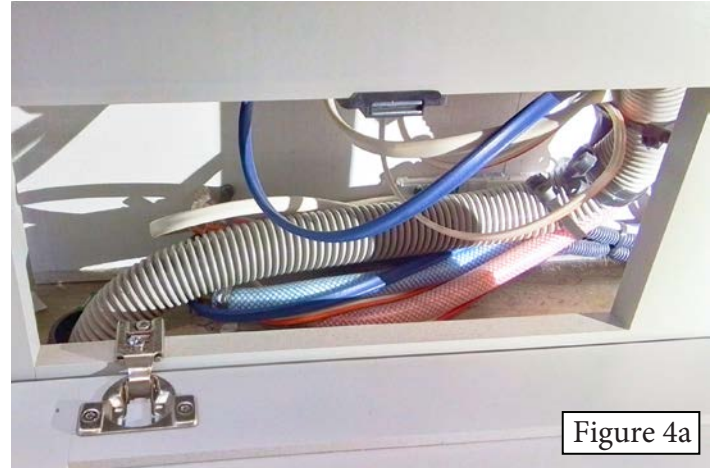

9. **NOTE** the colors of the wires and plumbing PRIOR to disconnecting them (Figure 4a and 4b).
10. Locate and identify plumbing and wiring components to be disconnected in preparation for slide-out removal (Figure 5).

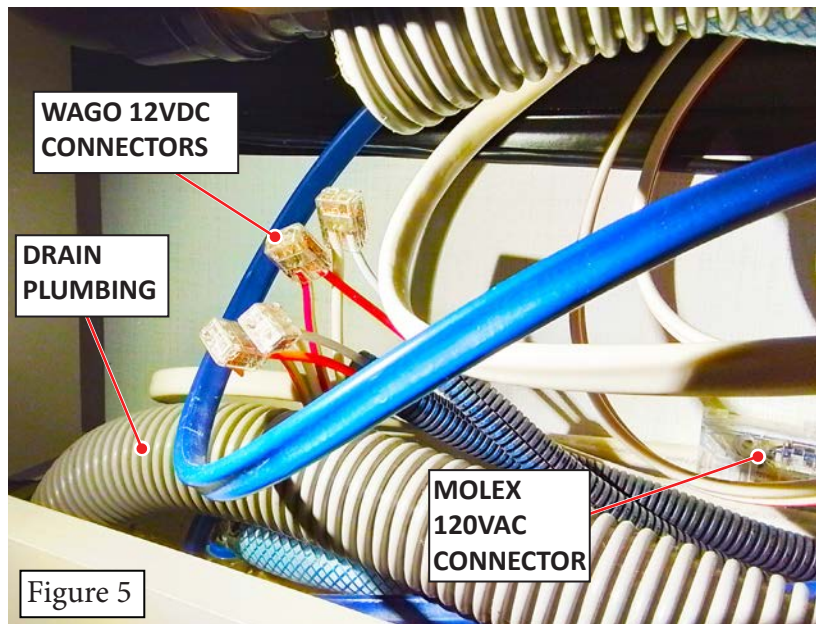
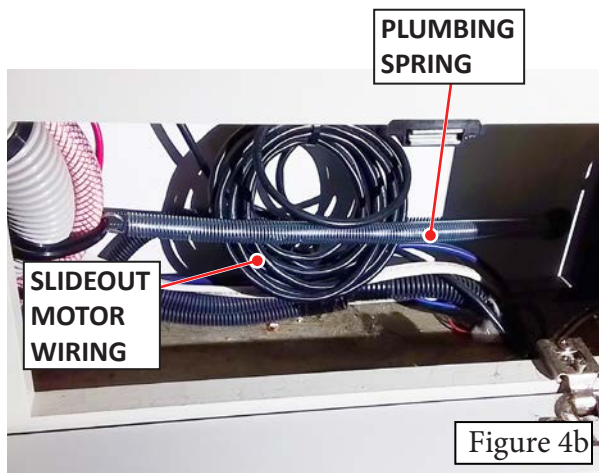

**+ NOTICE**

Place a bowl or towel under the plumbing to absorb any residual water that may come out when the drain line is disconnected. Failure to do so may lead to property damage.

11. Disconnect the drain plumbing at the barbed fitting, and the 12VDC wiring at the WAGO connectors (Figure 6a). Retain the WAGO connectors for future use.

12. Disconnect the fresh water lines at the fittings under the sink (Figure 6b).

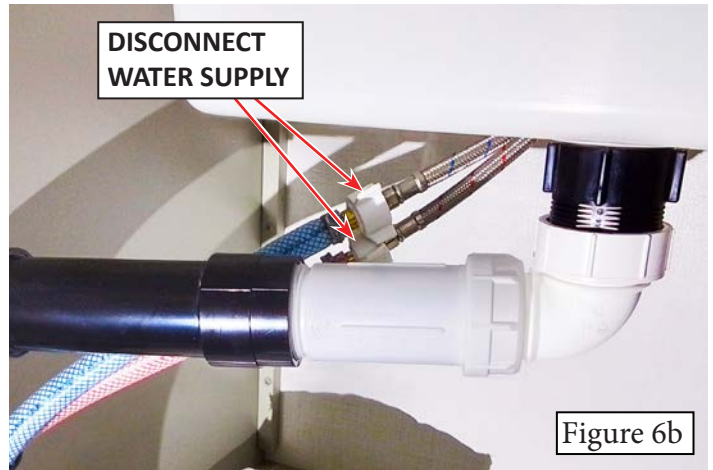
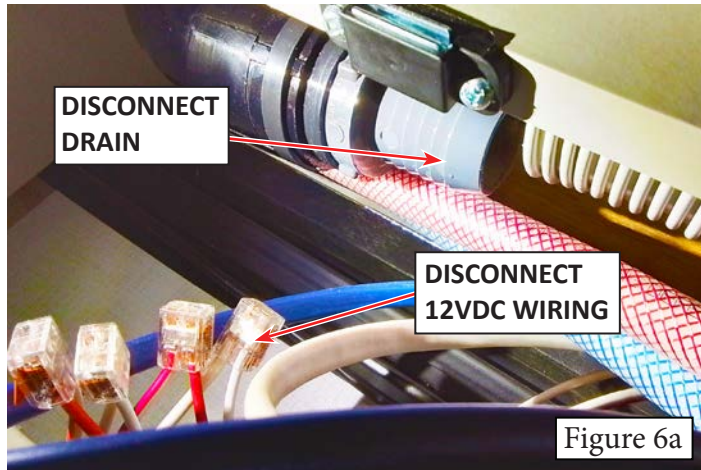

13. Disconnect the 120VAC wiring at the Molex connectors (Figure 6c).

14. Pull the loose plumbing and wiring out of the cabinet in preparation to remove the slide-out (Figure 6d).

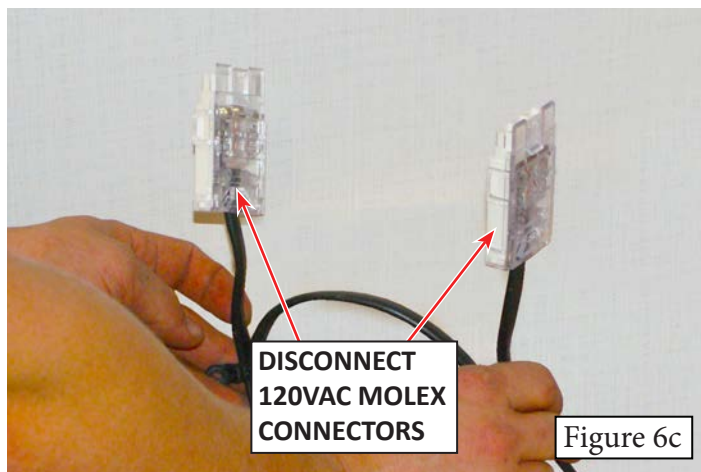

15. Proceed to slide-out removal, page 13.

## BEDROOM SLIDE-OUT REMOVAL PREP W/BED - ALL OTHER FLOOR PLANS EXCEPT Z3610)

### **⚠ WARNING**

**WARNING!** Turn off all electrical power to the RV PRIOR to beginning repairs. Be certain the RV is unplugged from shore power and the batteries are disconnected PRIOR to beginning welding. Failure to do so could result in property damage and injury or death.

### WORK INSTRUCTIONS:

1. READ AND UNDERSTAND ALL INSTRUCTIONS PRIOR TO BEGINNING WORK.
2. Remove all bedding and personal items from the bedroom slide-out area (Figure 1).
3. Remove the mattress from the bed platform and store elsewhere in the RV.(Figure 2).



4. Raise the bed platform to access the support struts below (Figure 3).
5. Disconnect the support struts from their brackets on the platform (Figure 4). Leave the struts attached to the bed base.



- Using a screw gun and a #2 square drive bit, remove the screws holding the bed platform to the hinge, and all of the screws holding the underlayment in place in the slide-out (Figure 5).
- Remove bed platform and underlayment, and set aside (Figure 6a and 6b).



- Remove the drawers from the bed base and set aside (Figure 7).
- Tape the bed struts in place and drawer openings to hold the drawer guides in place (Figure 8).



10. Access wiring in slide-out; label or photograph for re-installation, and carefully disconnect wiring (Figures 9a, 9b, 9c, and 9d). Retain Wago and Molex connectors for later installation reconnection.

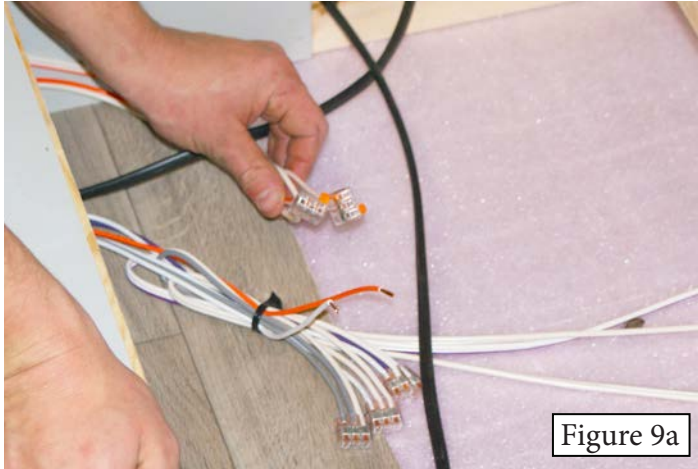

Figure 9a



Figure 9b



Figure 9c



Figure 9d

11. Using a screw gun and a #2 square drive bit, remove the end panels where the vent and receptacles were located (Figure 10).

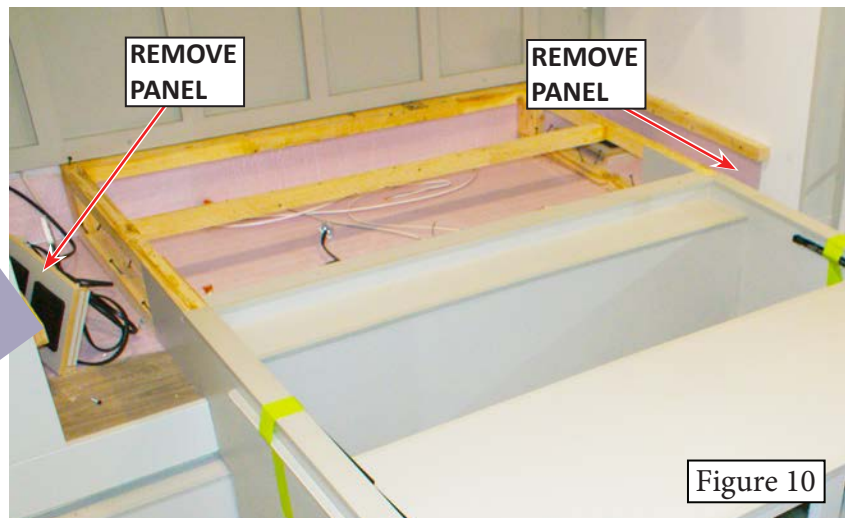
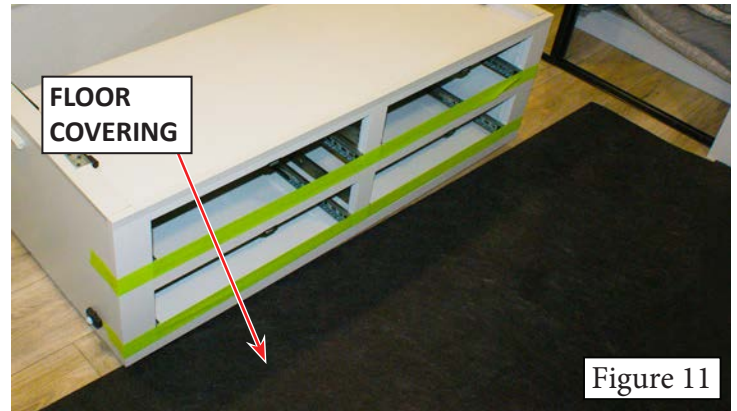

Figure 10

12. Cover the bedroom floor at the end of the bed base with carpet or cardboard to protect the linoleum during the next steps. (Figure 11) .



13. Remove all of the fasteners holding the bed frame to the slide-out (Figures 12a, 12b, and 12c).



14. Once all fasteners are loose or removed, rotate the bed frame slowly out of the slide-out and stand it on end in the bedroom (Figures 13a, 13b, 13c and 13d) on the floor covering previously installed. Use caution not to hit the ceiling or air conditioner during this process.

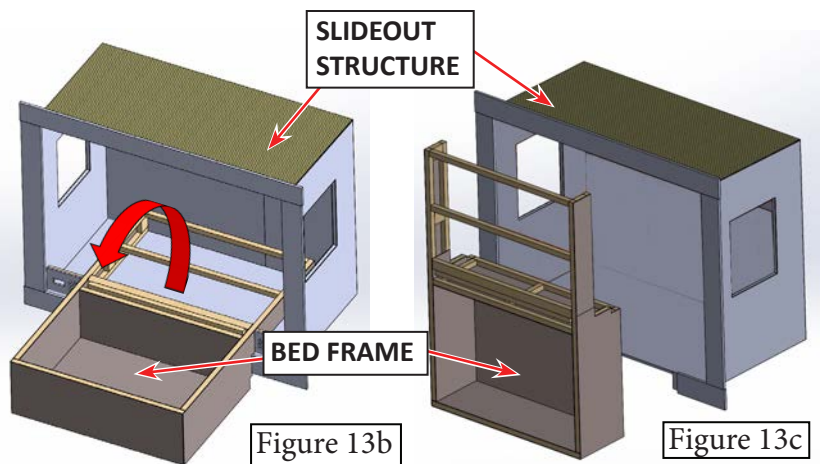



Figure 13d

15. Retract the bedroom slide to a position where it is approximately halfway in (Figure 14) to access the back side of the fascias.
16. Using a screw gun and #2 square drive bit, locate and remove the screws located on the back side of the fascia panels (Figure 15).

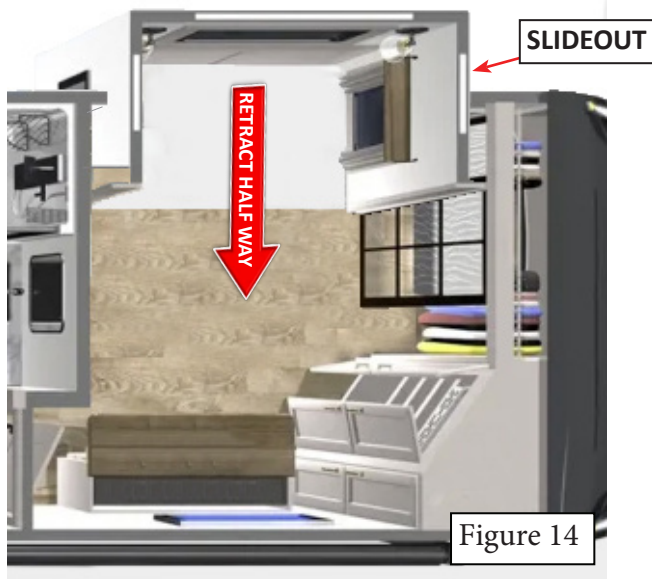

Figure 14

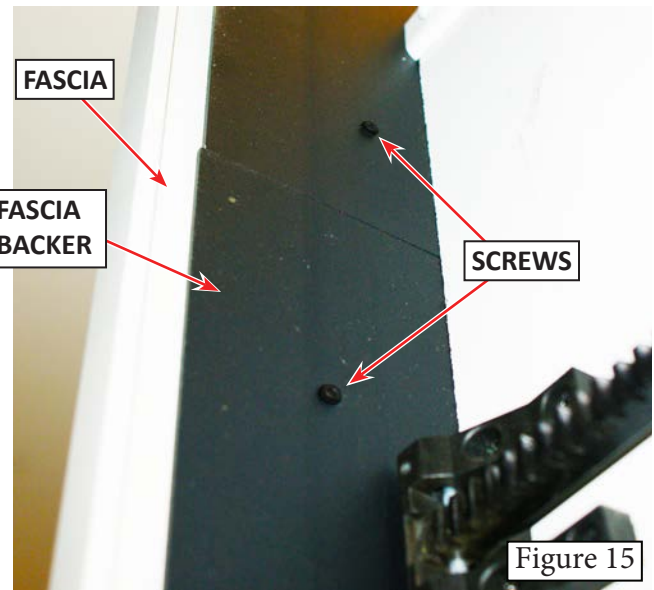
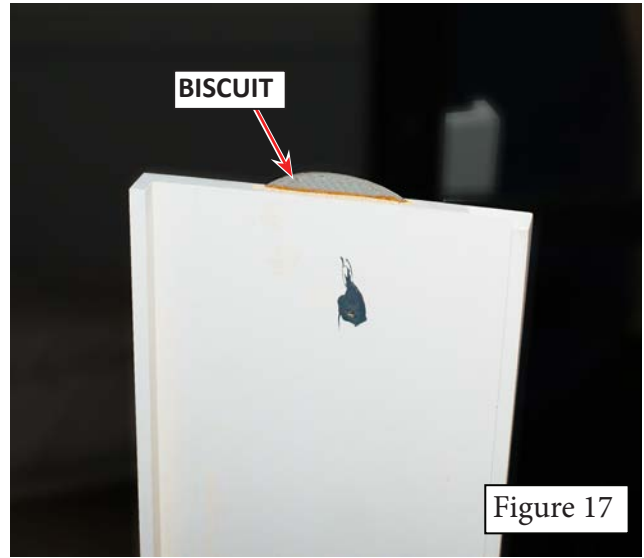
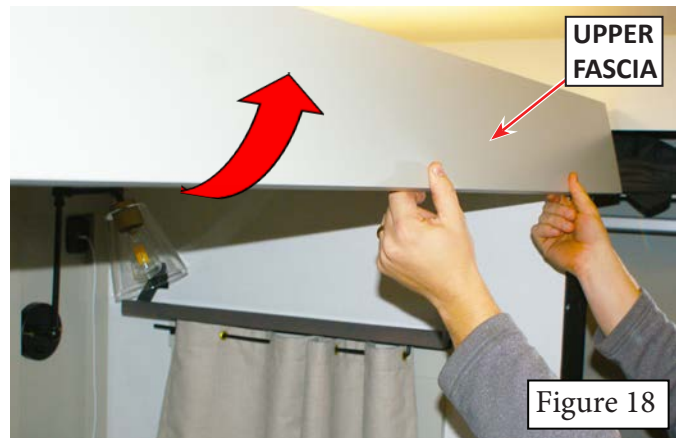

Figure 15

17. Pull the side fascias off by pulling out from the bottom of the fascia first (Figure 16), then pulling down to disengage the biscuit joint where the side fascia meets the top fascia (Figure 17). Note that there are spot applications of CHEM-X adhesive on the backs of the fascia boards, so it may require a prying tool to remove them from the backers. **Where possible, retain original fascia boards for later reuse.**



18. The top fascia has a channel on the backside of it that hooks over the top of the backplate. Pull out from the bottom first and then push up to pop the fascia off the backplate (Figure 18). If not damaged during removal, set fascia boards aside for later use. If damaged during removal, replace damaged fascia boards with provided parts (not shown).



19. Using a screw gun and a #2 square drive bit, remove the fasteners holding the backer plates on the slide-out (Figures 19a and 19b). Remove the 5 individual backer plates used. The bottom corner pieces have longer screws than the rest of the plates. Retain plates and fasteners for later use.

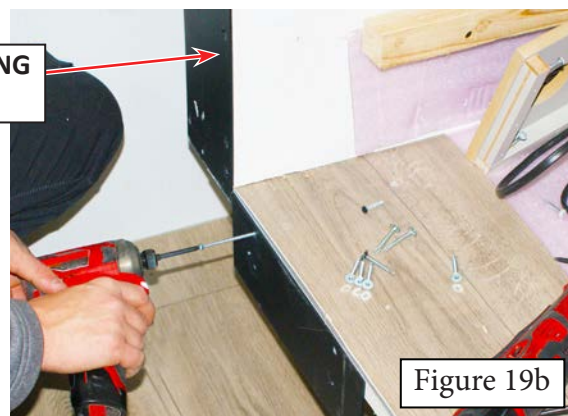
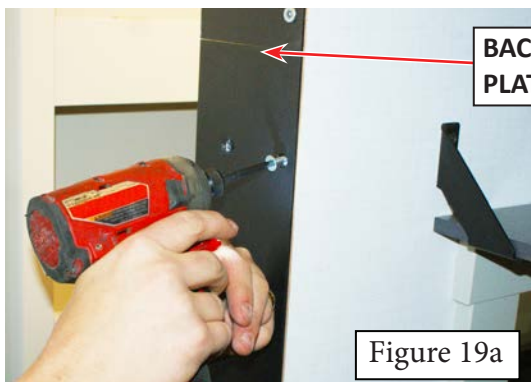

20. Proceed to slide-out removal, page 13.

## REMOVING BEDROOM SLIDE-OUT FROM RV

### ⚠ WARNING

**WARNING:** The next steps involve moving and removing the bedroom slide-out from the RV. **EXTREME CAUTION** should be observed during this process to make sure the slide-out is properly braced and supported to prevent it from falling. Have dollies or carts available to place the slide-out on once removed from the RV. Failure to do so may cause death, serious personal injury, severe product and/or property damage if not performed safely and within the parameters set forth in this document.

1. Remove the T-bracket on the outside bottom edge of the slide-out (Figure 1a and 1b).
2. Extend the slide-out room fully outward and support from below using a forklift (Figure 2).

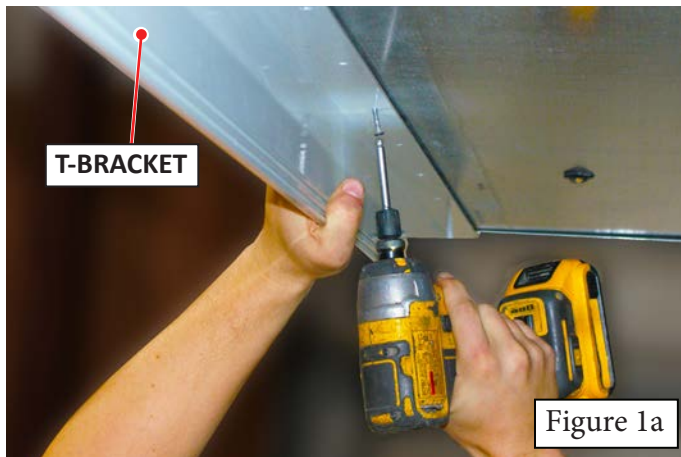

Figure 1a

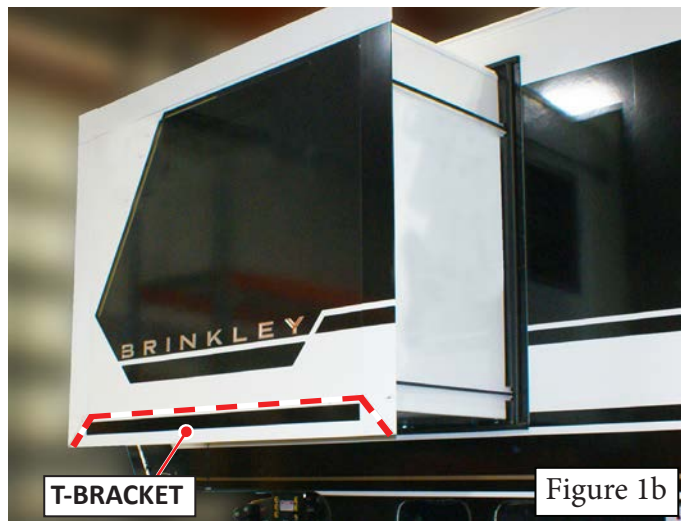
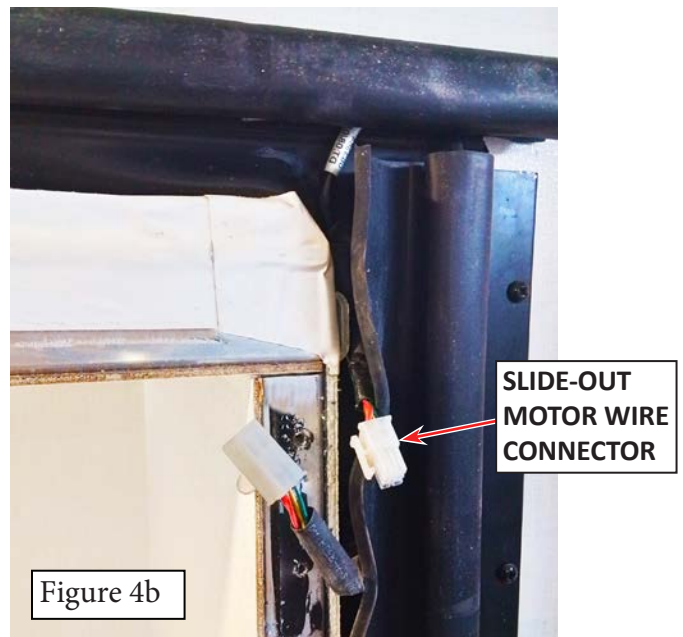
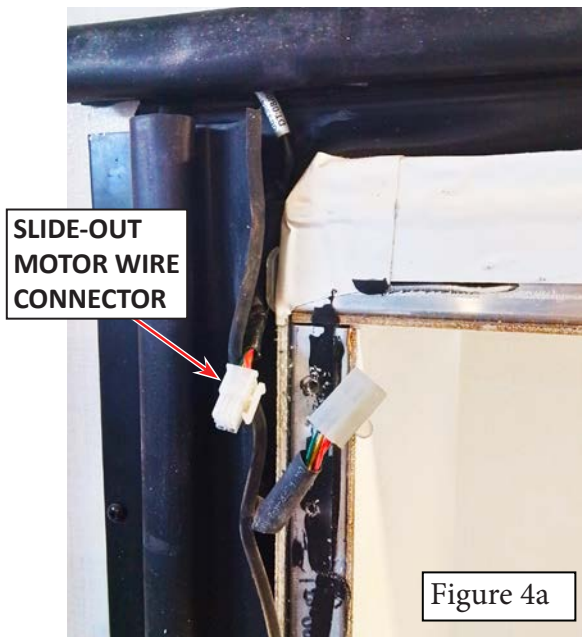
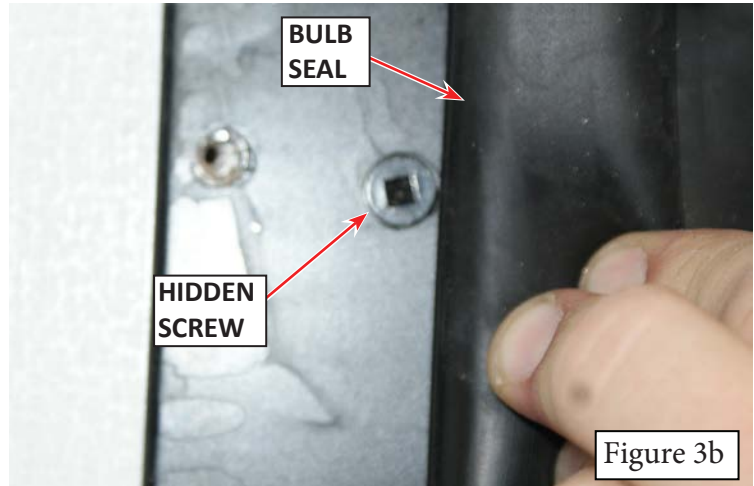
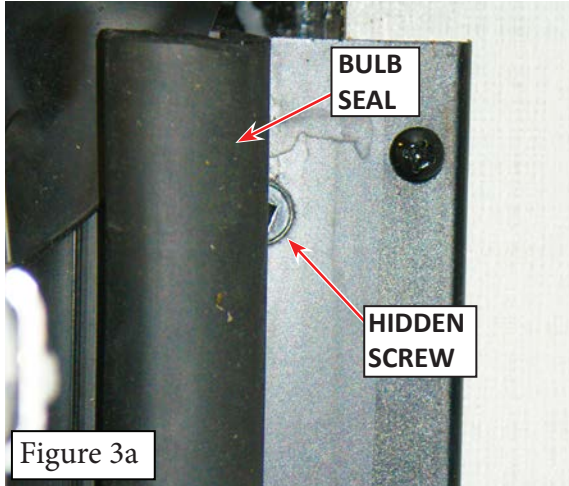

Figure 1b



Figure 2

3. Use a screw gun and a #2 square drive bit to remove all of the column screws including the four (4) fasteners hidden behind the bulb seal on each side of the slide-out (Figure 3a and 3b).
4. Pull the interior portion of the column and wipe seal away from the wall. Locate the wires to the slide-out drive motors. This wiring and connector will be located at the top of the slide-out sides. Pull apart the motor connection (Figure 4a) and feed the motor end of the connector through the hole in the wipe seal (Figure 4b).



5. Remove screws from the outside of the slide mechanism column (Figure 5).
6. Use a razor knife to cut the sealant away between the vertical columns and the sidewall (Figure 6a), while using a prying tool to pry the vertical columns away from the sidewalls (Figure 6b and 6c).



7. Prepare a cart, or a platform to set the slide-out on when it is removed from the RV (Figure 7 or similar).
8. Remove the slide-out from the RV. Gently lift the slide-out room in the opening. Tip it backwards (out at the top) and rotate the wardrobe end outward to allow clearance for the lav cabinet (Figure 8a and 8b). Once the top has cleared the opening in the wall, lift the slide-out enough to clear the lav cabinet over the lip in the slide-out opening in the sidewall (Figure 8b). **NOTE: Remove the room slowly, and be certain the wiring and plumbing under the lav cabinet and wardrobe do not catch on anything as the room is lifted and removed.**
9. Remove the slide-out and place it on the cart and floor (Figure 9). Remove and clean all residual adhesive from the slide-out columns.



Figure 7



Figure 8a



Figure 8b

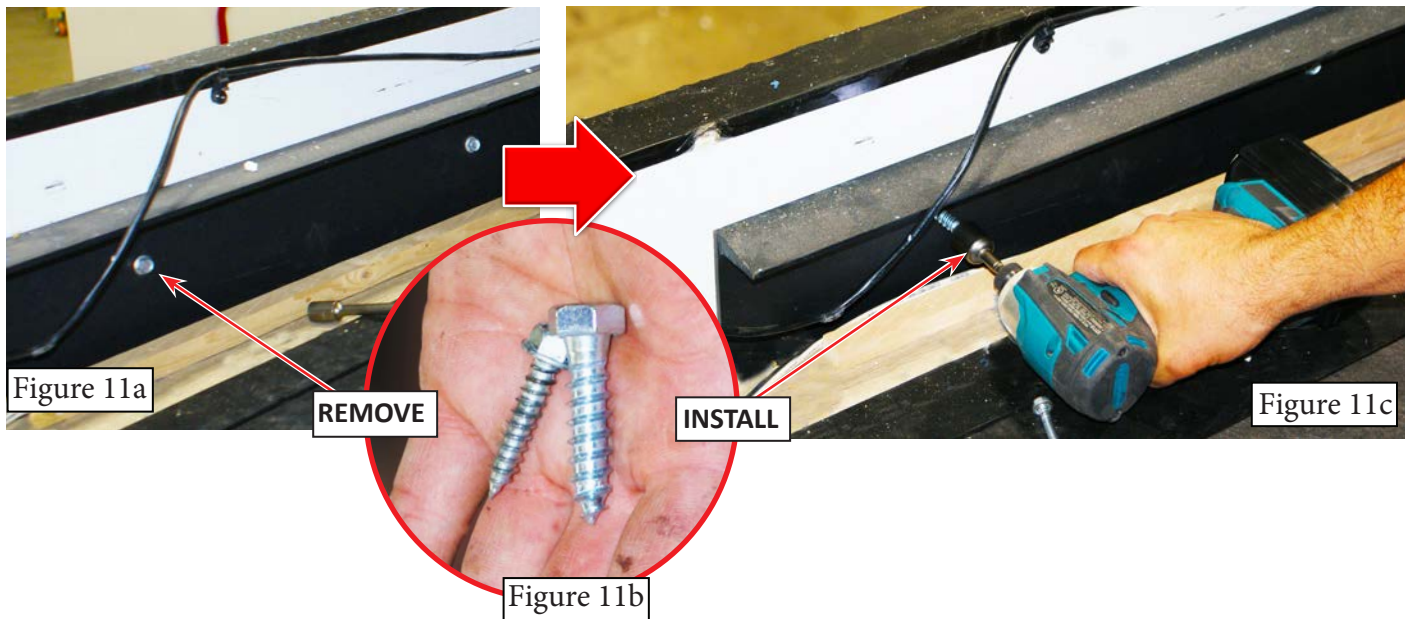

Figure 9

10. Use a screw gun and #2 square drive bit to remove the fasteners holding the slide-out rollers on the bulb seal at the bottom of the slide-out opening (Figure 10). Discard the old rollers.



11. Use a screw gun and a 1/4" socket to remove the 1/4" X 1.5" fasteners holding the lower wall brace in place (Figure 11a).
12. Use the screw gun and a 3/8" socket to install 3/8" X 1.5" hex head lag bolts (P/N T110390) in place of the original fasteners (Figure 11b and 11c). Tighten fasteners to tight - no torque spec.



**+ NOTICE**

If the bedroom slide-out has a composite floor, proceed to Step 1 on page 24 (Front Cap Removal). If the bedroom slideout has a plywood floor, continue with Step 13 below for the procedure to replace the plywood with a new composite floor. Do this **ONLY** if the bedroom slide-out has a plywood floor!

13. Prepare two wooden supports from 2”x 6” boards, approximately 4’ x 6” x 6” on the floor to rest the slide-out box on, and cover top surfaces with styrofoam (or other soft material) to prevent damage to the exterior face of the slide-out (Figure 12).
14. Remove the slide-out from the RV and place it on the floor, then rotate the slide-out room face down onto the supports (Figure 13).

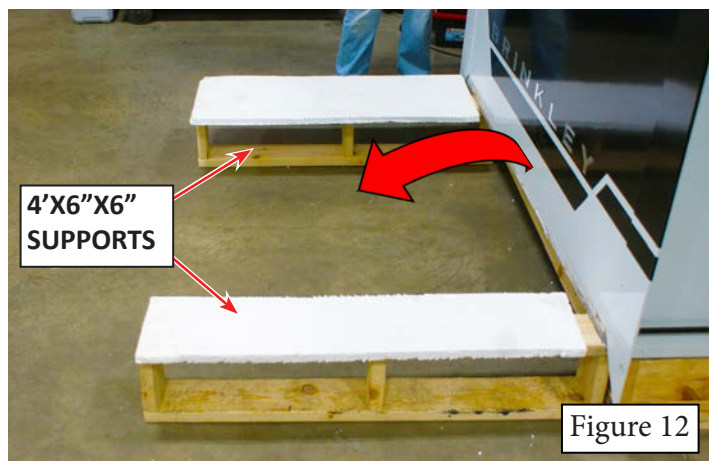

15. Remove the slide-out columns from the sides of the slide-out room (Figure 14) by sliding them out of their mounting brackets. NOTE that there is a small plastic rivet that will break while trying to remove the columns; this can be replaced during re-installation with another plastic rivet or a screw (not provided).
16. Using a screw gun and a #2 square drive bit, remove the fasteners holding the L-shaped bottom slide corners from the slide-out box (Figure 15).

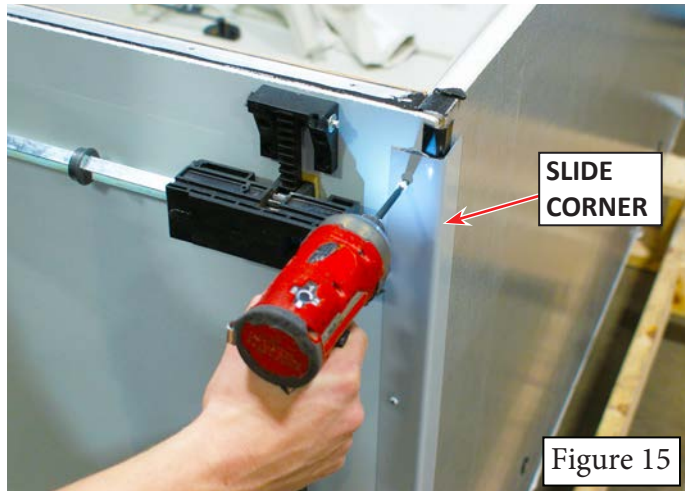
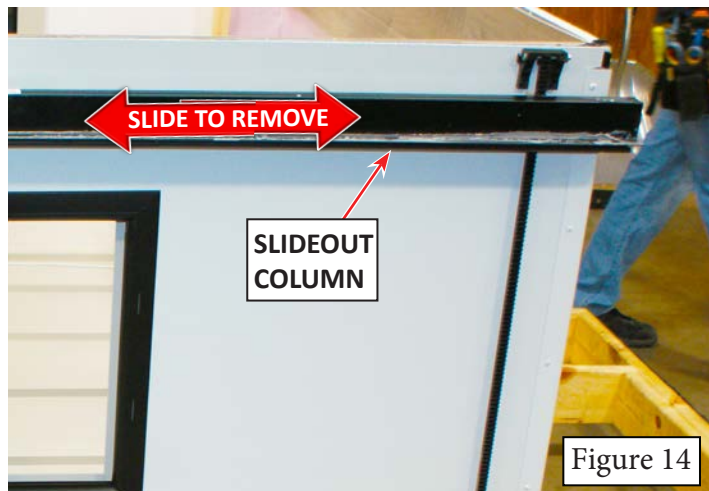

17. Once the fasteners are removed, remove the slide corners. You may have to pry the corners off the slide box (Figure 16). Note - if they are damaged during removal, replace them (replacements provided in initial parts shipment - P/N 105066).
18. Once the slide corners are removed, use a razor knife to cut the seam between the floor seal and the wall (Figure 17).

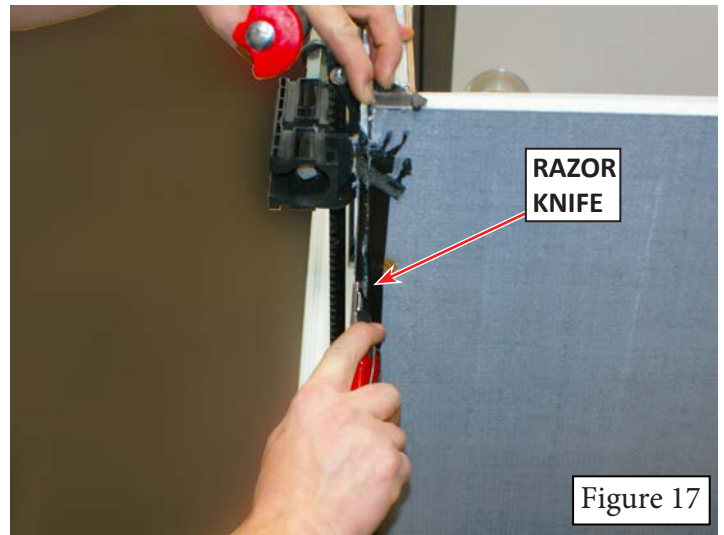
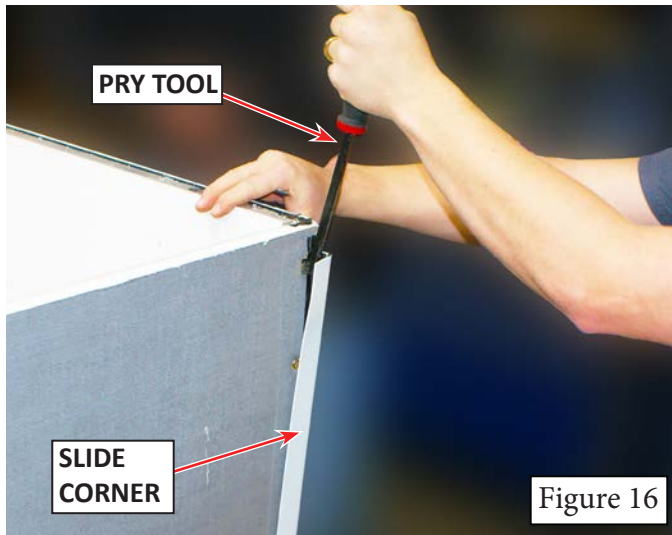

19. Using a screw gun and a #2 square drive bit, remove the fasteners that hold the slide-out floor to the slide-out sidewalls (Figure 18).
20. Remove the screws holding the slide-out floor to the outside slide-out wall (Figure 19). **NOTE that these screws may be hidden under seam tape** (Eterna-Bond tape - P/N 102405 - replacement tape supplied).

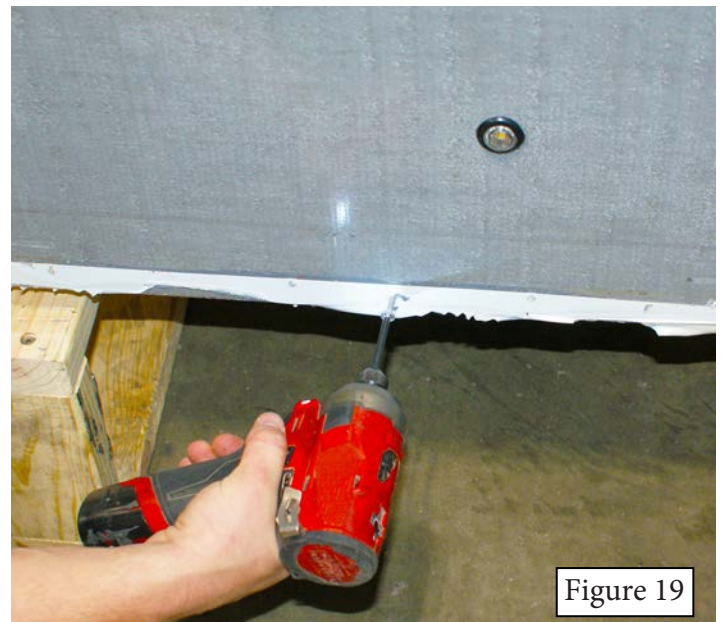

21. Use wire cutters to cut the securing zip tie and remove the wire clamps for the under slide lights (Figure 20a) and disconnect the wires (Figure 20b).

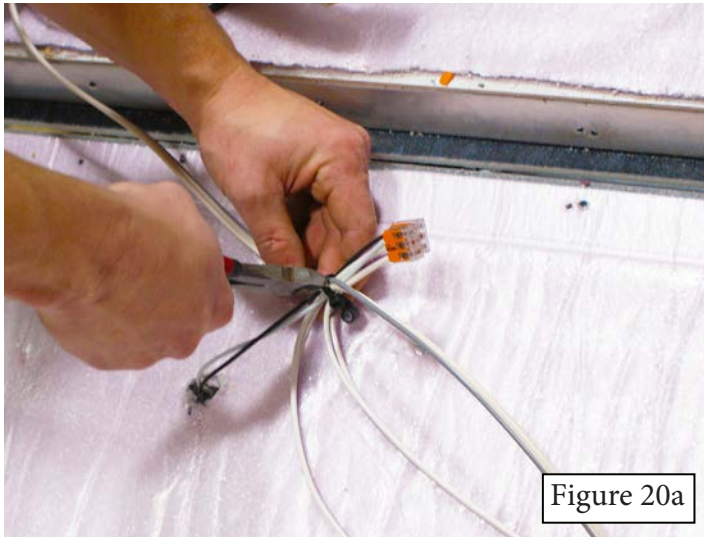

Figure 20a

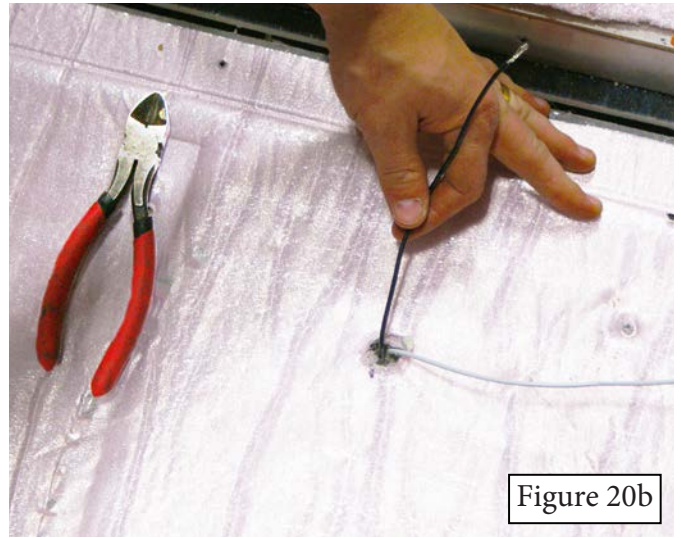

Figure 20b

22. Push the lights out of the floor and remove the grommets through the holes they are mounted in (Figure 21a). Retain lights and grommets for re-installation in new floor (Figure 22b). Remove and discard the original floor.



Figure 21a



Figure 22b

23. Lay new slide-out floor on supports with the interior side facing up. Lay pink insulation (P/N 101851) over the floor and cut about an inch longer than the room. Peel the backing off of the adhesive on the pink insulation and flip the insulation so the adhesive side is down (Figure 23).
24. Apply insulation to the floor and trim to fit (Figure 24).



Figure 23

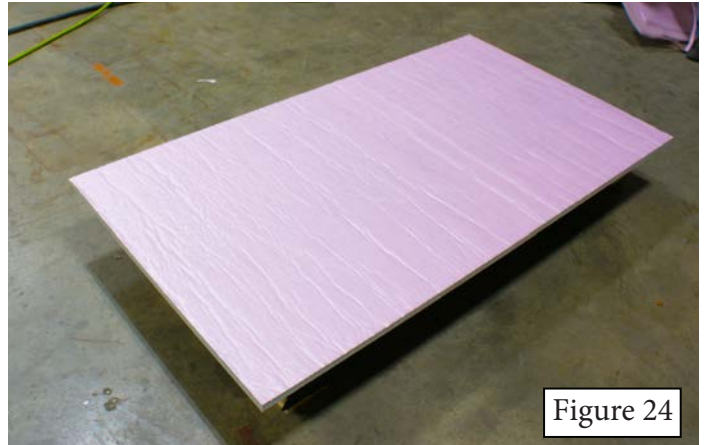

Figure 24

25. Flip the floor over. Measure out the hole centers for the under slide lights (6" in from the outside face edge of the floor and 18 1/4" in from the side edge of the floor) (Figure 25).
26. Use a power drill and a 3/8" spade drill bit to drill the holes for the LED lights (Figure 26).

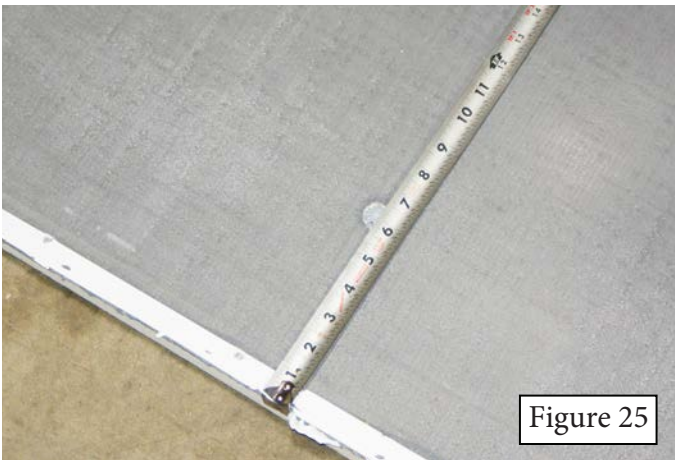
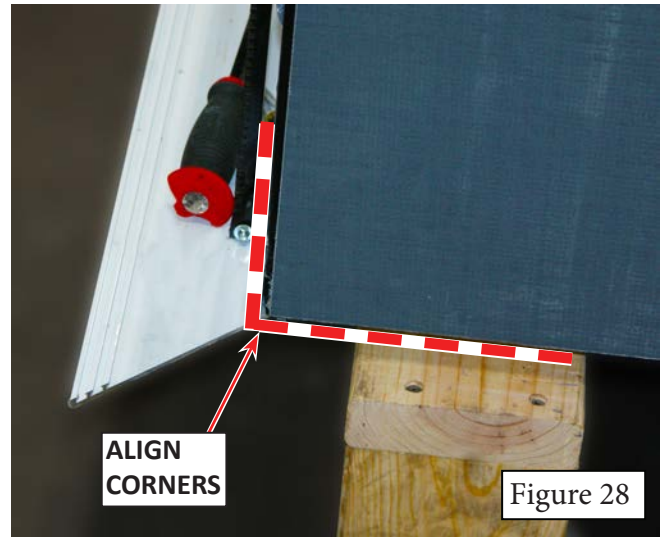
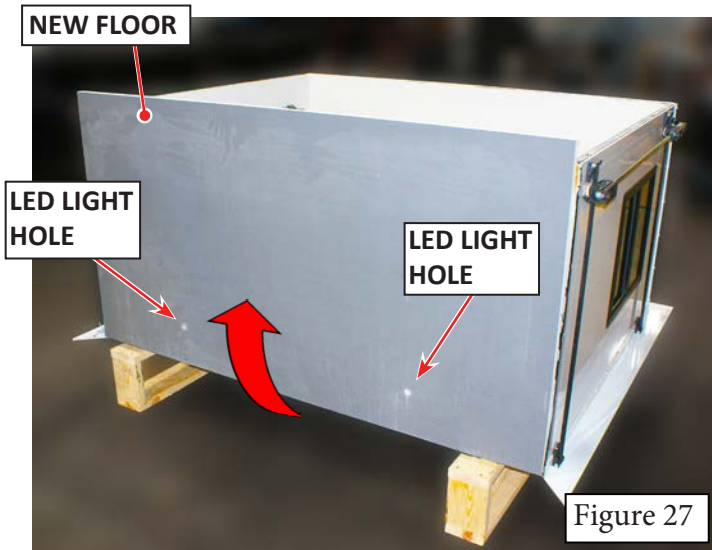

Figure 25

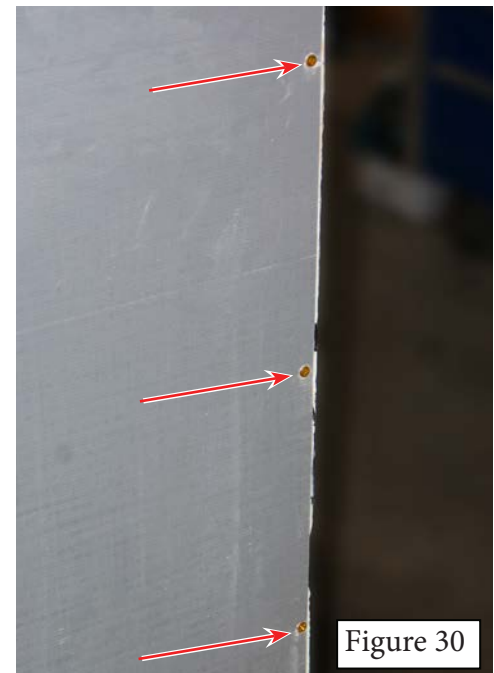

Figure 26

27. Lift the new floor and set into place against the bottom of the slide room walls. The holes for the lights should be near the outside face of the slide room and the pink insulation should be facing the ceiling of the slide room (Figure 27).
28. Line up the bottom corners of the floor with the slide room walls first (Figure 28).



29. Using a screw gun with a #2 bit, secure the bottom corners of the room to the floor with one (1) 14 X 1.5 ZINC (P/N 100883) screw in each outside corner (Figure 29).
30. Align the walls with the floor and ensure the slide room remains in square. Secure the other two corners of the room with one (1) 14 X 1.5 ZINC (P/N 100883 - NOT provided) screw in each corner, **then secure the rest of the wall using at least four (4) of the same 14 X 1.5 ZINC screws per wall** (Figure 30).



31. Once the side walls are secure, align the outside wall and hold the removed T-Molding in place and mark the screw locations in the T-Molding. This will prevent from screwing the T-molding into an already existing screw from the floor (NOT shown).
32. Using a screw gun with a #2 square drive bit, attach the floor to the outside wall with eight (8) 10 X 3 screws (P/N 100880) (Figure 31). **There should be a minimum of 8 screws through the floor into the outside wall.**
33. Using an oscillating multi tool with a chisel blade (or equivalent), remove any old sealant along the floor line of the slide-out (Figure 32).

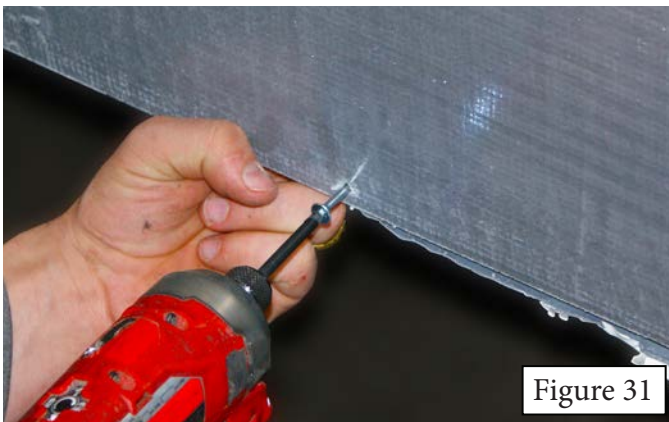

Figure 31

Figure 32

34. Place Eternabond seal strips (P/N 102489 ) over the side wall to floor corners of the slide room. Trim them around the T-molding. Make sure the strips completely cover the screw heads for the floor (Figures 33a and 33b).



Figure 33a

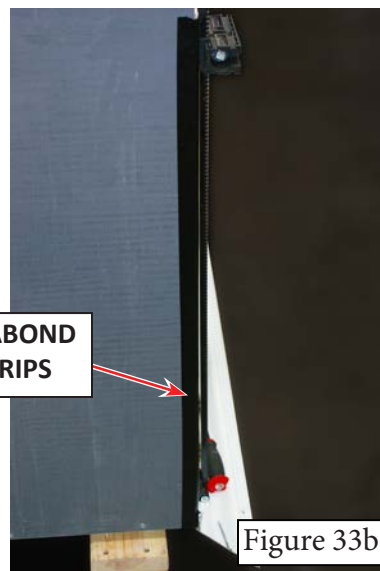
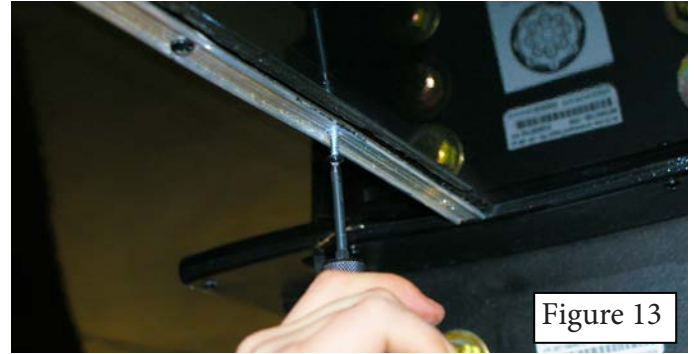

Figure 33b

## FRONT CAP REMOVAL

1. Using a razor knife, score along both sides of the snap-on trim all the way around the cap (Figure 12).
2. Using a screw gun with a #2 square drive bit, remove the screws from the ends and corners of the snap-on trim, then peel the trim away from the retainer (Figure 13).



3. Using a screw gun and a #2 square drive bit, remove the screws from the pinbox shroud (Figure 14a and 14b). Note that some screws may require a 90° adapter to access (Figure 14b).

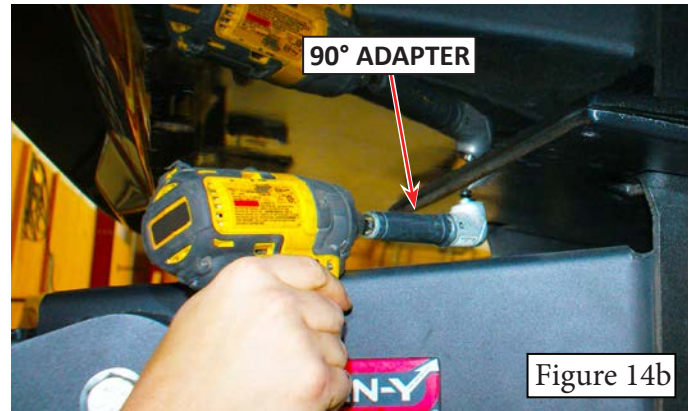

4. Remove both pieces of the pinbox shroud and set aside safely (Figure 15).
5. Support the cap with a forklift that is padded to protect the cap (Figure 16).

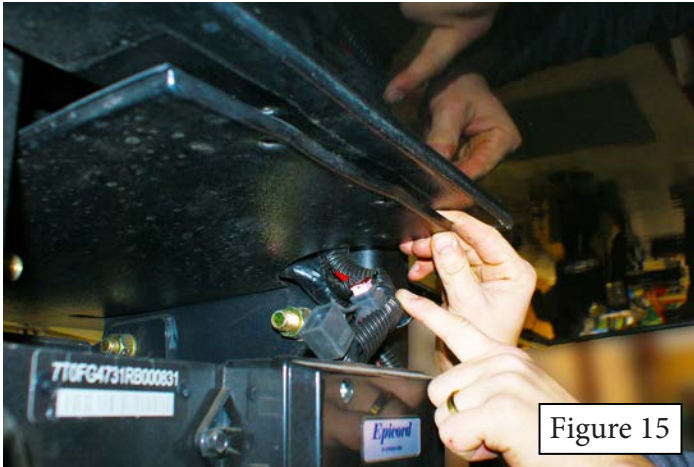

Figure 15



Figure 16

6. Pry around the edges of the cap to loosen the sealant and separate the cap from the side walls and roof (Figures 17a, 17b, 17c and 17d). Check for hidden screws under the sealant.



Figure 17a



Figure 17b

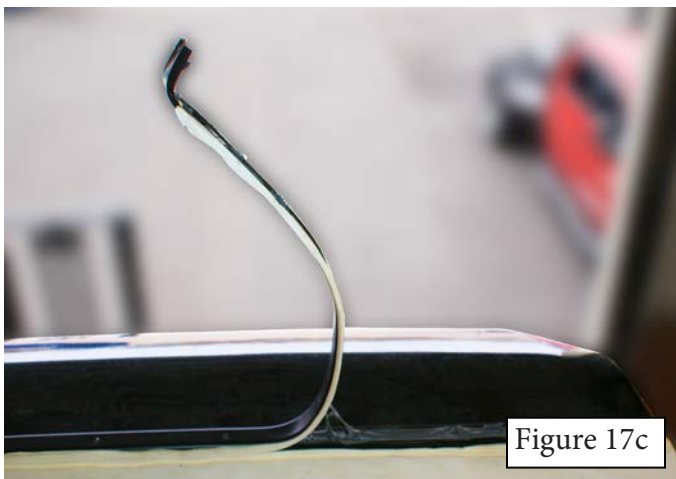

Figure 17c



Figure 17d

7. Pull cap back and disconnect the lighting wiring from the cap (Figure 18a and 18b).
8. Set cap safely aside and protect it for re-installation (not shown).

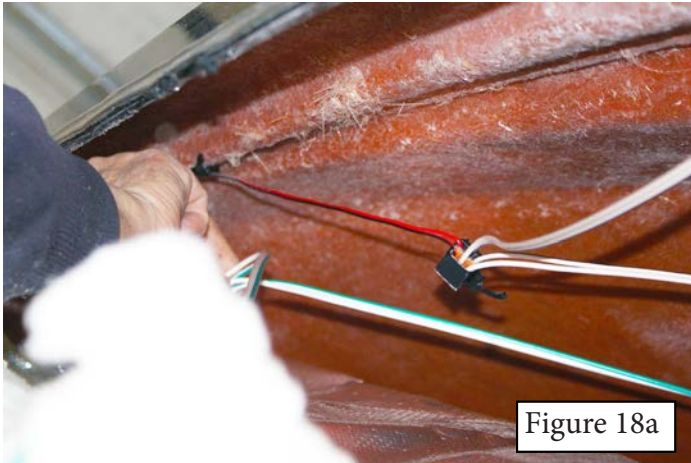

Figure 18a

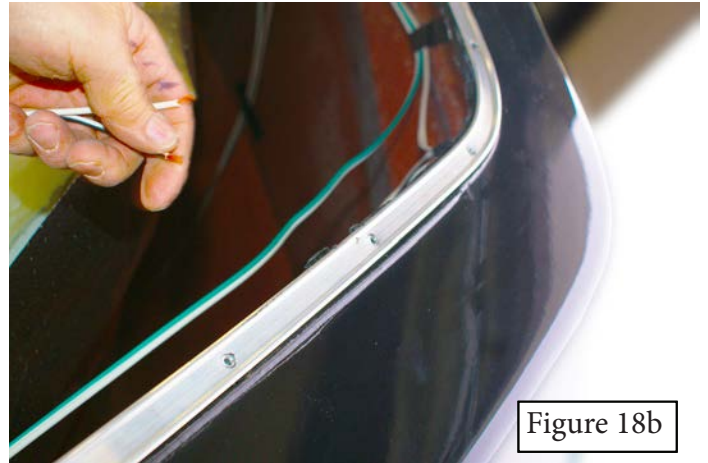

Figure 18b

### SIDEWALL REMOVAL

1. Use a screw gun with a #2 square drive bit and prying tools to remove the fasteners and peel off the rubber drip rail trim along the roof line to the back of the kitchen slide-out (Figure 19).
2. Using prying tools, remove the drip rail j-channel from the roof line (Figure 20 and 21).

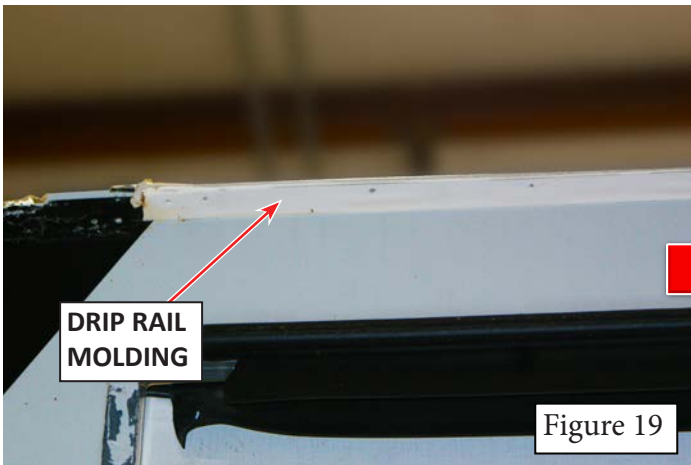

Figure 19

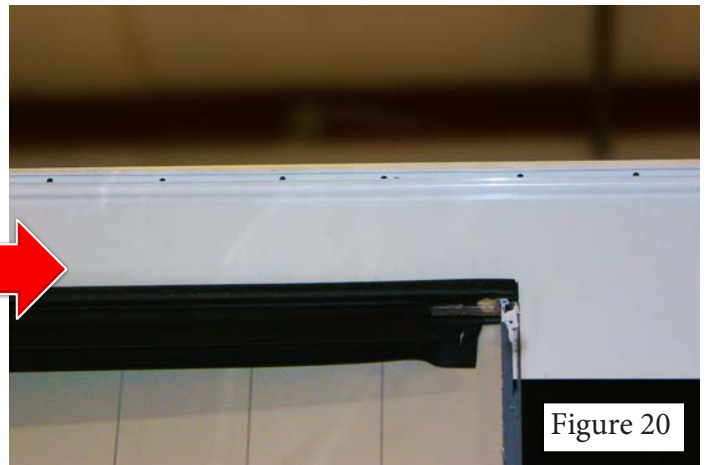

Figure 20

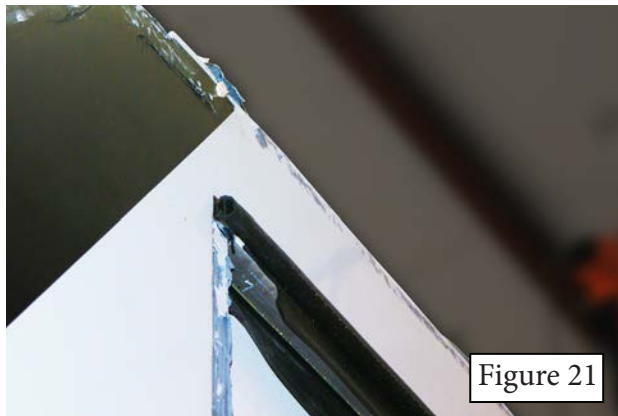
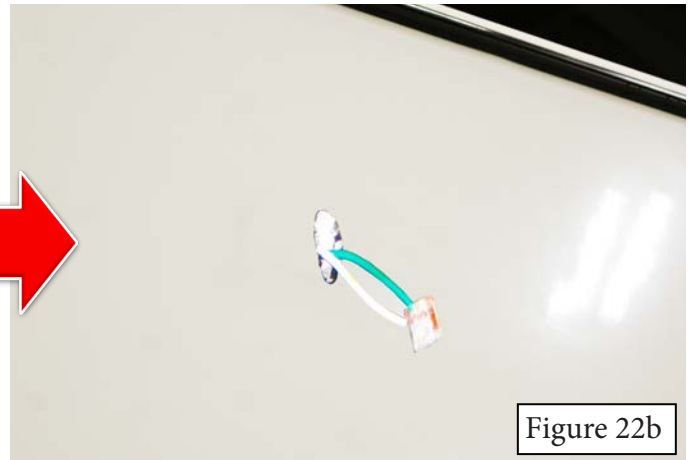
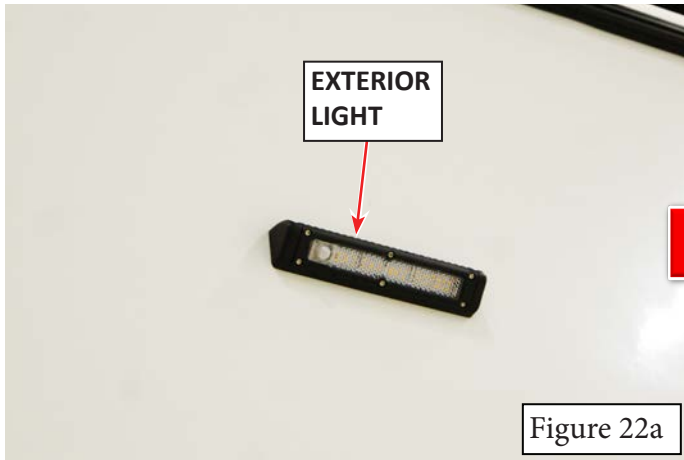
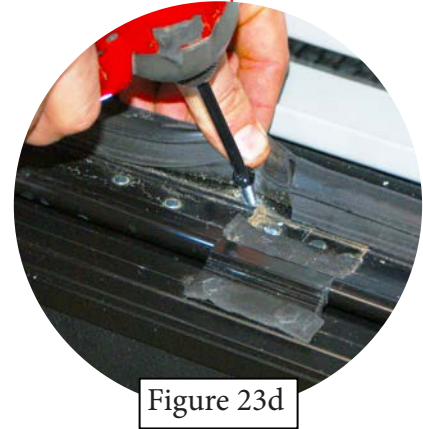
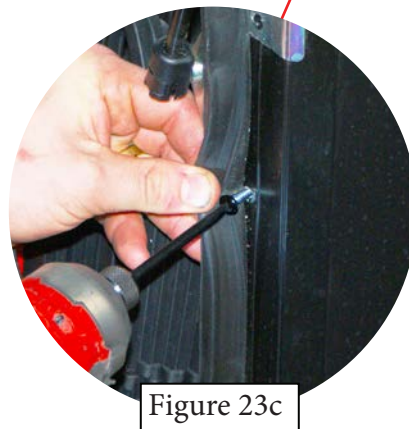
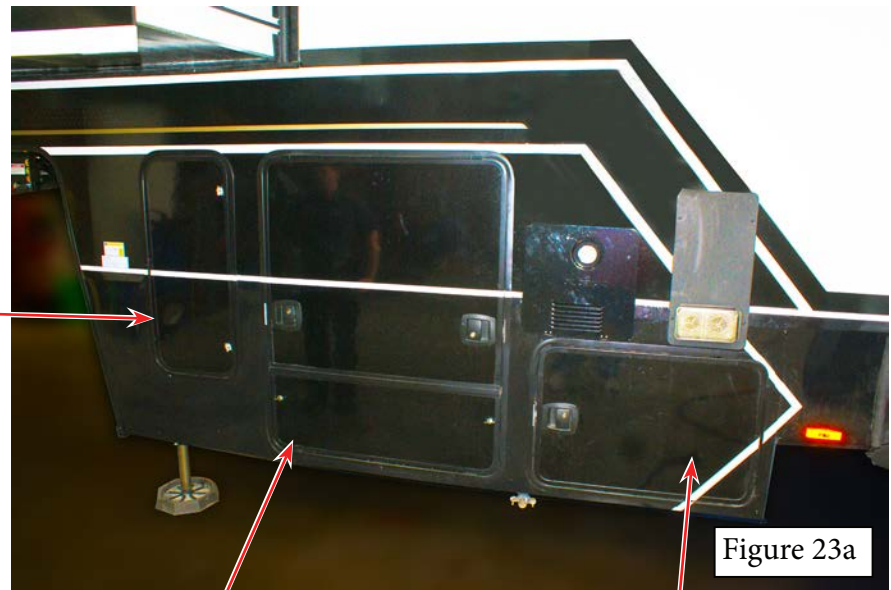
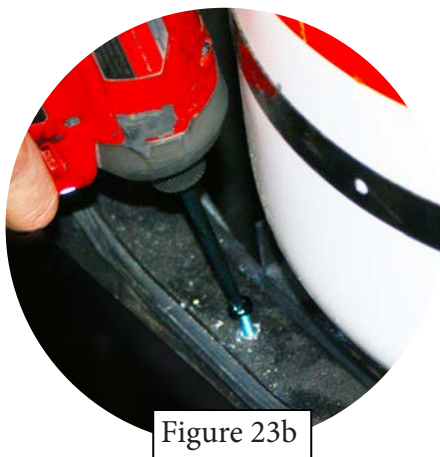

Figure 21

3. Use a screwgun and #2 square drive bit to remove the exterior light from the side wall (Figure 22a and 22b).



4. Remove all of the baggage doors and water heater covers from the side wall. The doors are held in place with #2 square drive fasteners: **NOTE that some of the fasteners are hidden under weatherstrips and trim** (Figure 23a, 23b, 23c and 23d).



**⚠ WARNING**

**WARNING** - Make sure the RV is unplugged from ALL power sources (including shore power) and all disconnects are turned "OFF". Failure to do so can result in death, serious personal injury, severe product and/or property damage.

5. Use a screw gun with a #2 square drive bit to remove the four (4) screws holding the shore power cord connector to the sidewall (Figure 23e).
6. Pull the shore power cord connector out of the sidewall: gently pull the cord attached to it out with the connector (Figure 23f). Loosen the plastic nut (or compression cap) on the back of the receptical to release tension on the cord (Page 29, Figure 23h).

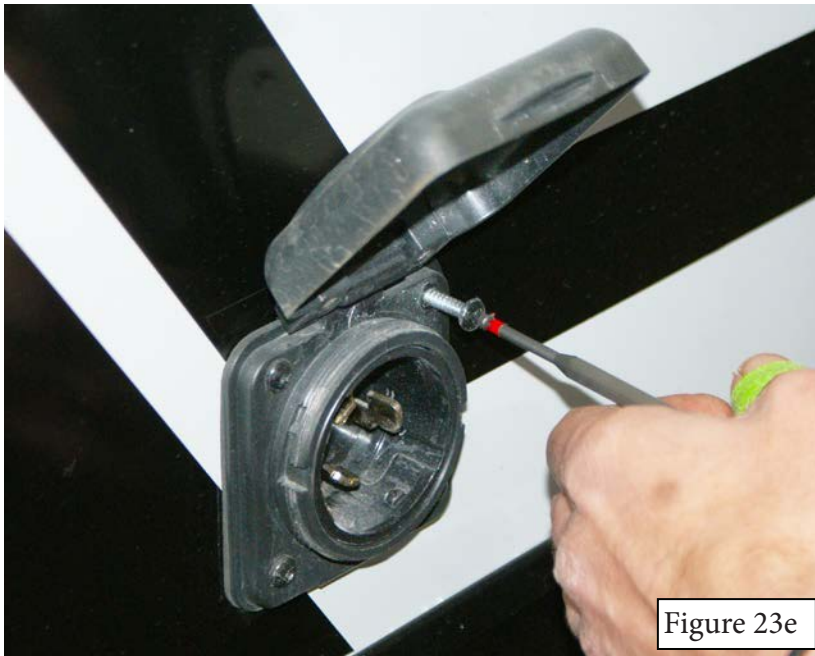

Figure 23e



Figure 23f

**+ NOTICE**

**NOTICE** - The power cord attached to the back of the shore power cord connector is anchored to RV structure with a P-clamp. When pulling the cord out of the RV, you may need to access that clamp to release the cord to remove and reinstall the shore power cord connector.

Access can be gained by loosening the furnace and sliding it to the side in the opening far enough to allow your arm to reach behind the wall to reach the P-clamp (Figure 23g).

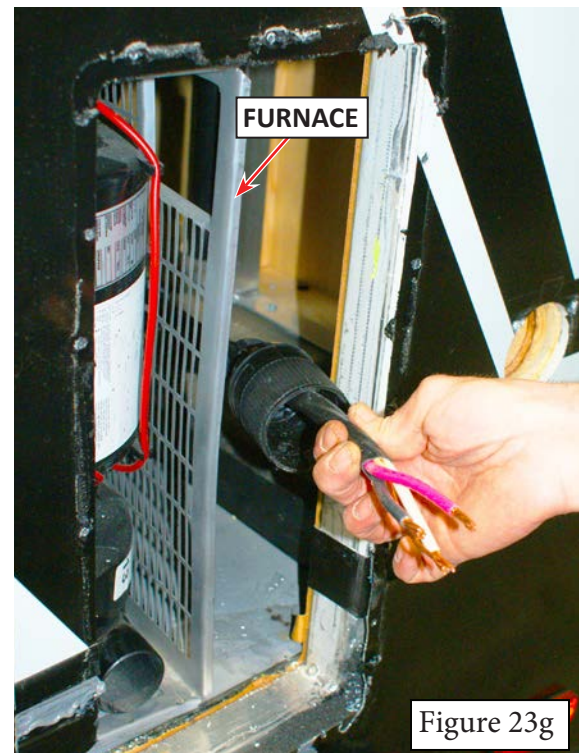

Figure 23g

**+ NOTICE**

**NOTICE:** The following steps involve removing the shore power cord connector wiring cover. Brinkley uses two (2) different types of these: installation and removal are virtually identical, but there are slight differences in the way the back covers are removed that will affect how you access the wire connections.

- The Furrion connector uses two screws that pass through the front connection opening to hold the rear wiring cover in place (Figure 23h). Remove the two (2) screws with a **HAND SCREWDRIVER with a #1 Phillips bit**, then remove the plastic nut at the end of the back cover to release tension on the wires. Remove the back cover to access the wire connections.
- The Epicord connector uses a “twist-lock” action to lock the rear wiring cover to the back of the connector base (Figure 23k). Twist the compression cap at the end of the rear cover loose to relieve the tension on the wires. Twist the rear cover counter-clockwise until it releases from the back of the power inlet and slide it back to access the wiring connections.

Once the rear cover is removed, the wiring process is the same on both connectors.

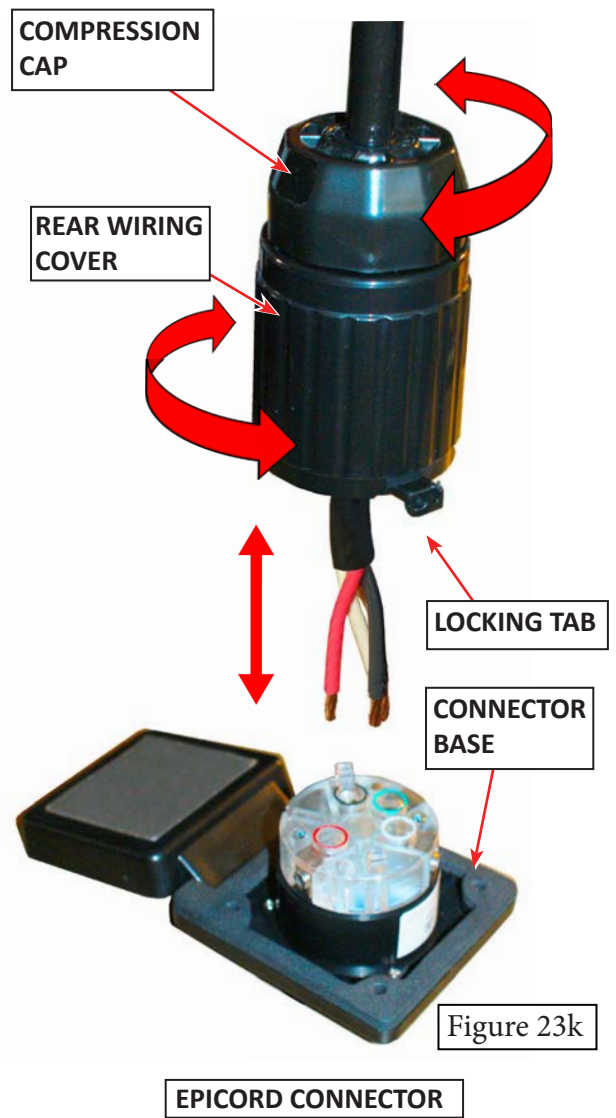
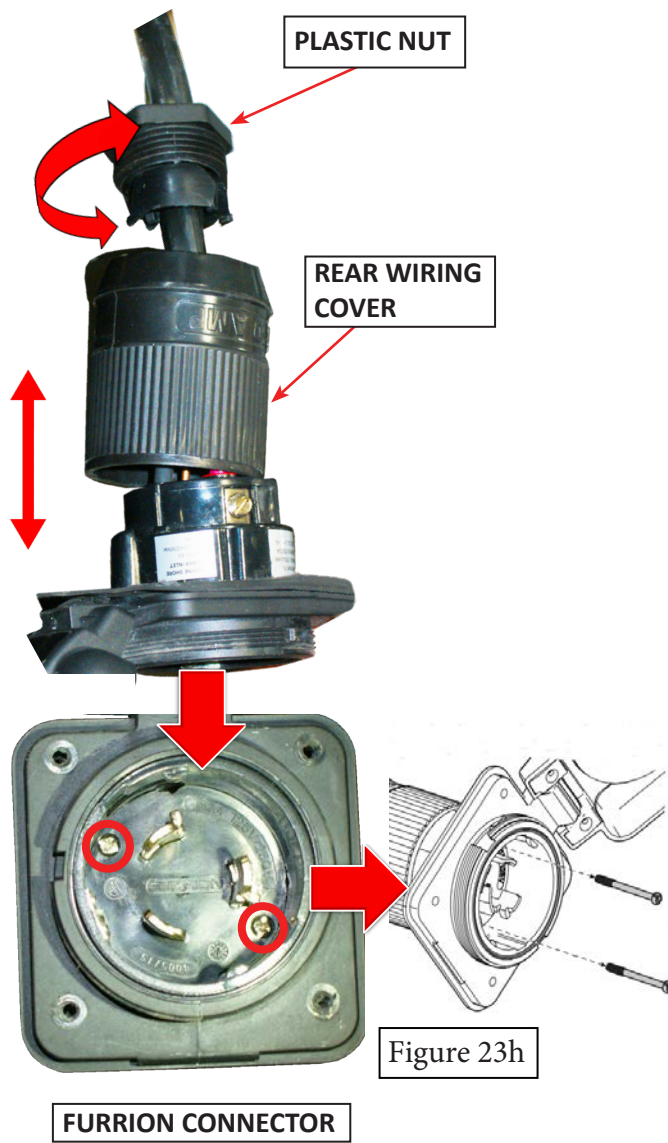

7. Slide the rear housing off the back of the receptical (Figure 23m) to expose the wire connections.
8. Use a hand held screw driver with the appropriate bit (flat head, Phillips head or #2 square drive) to loosen the four (4) screws holding the wires in position on the back of the receptical (Figure 23n).

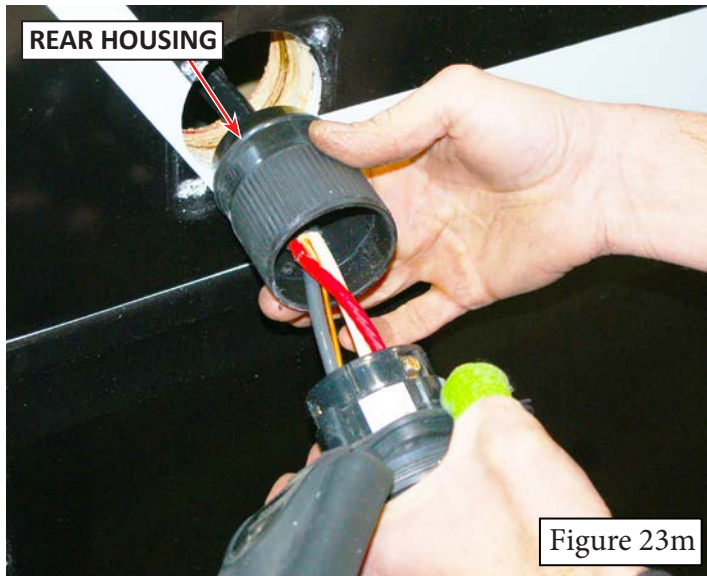

Figure 23m



Figure 23n

9. Pull the wiring out of the back of the receptical (Figure 23p). Cap the wires and insert them back through the hole in the sidewall. Set receptical and all associated parts aside for later reinstallation (Figure 23s).

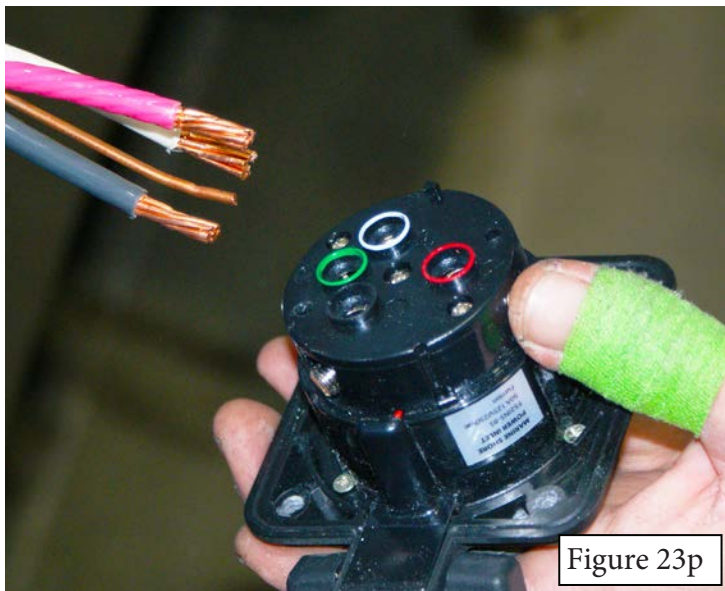

Figure 23p

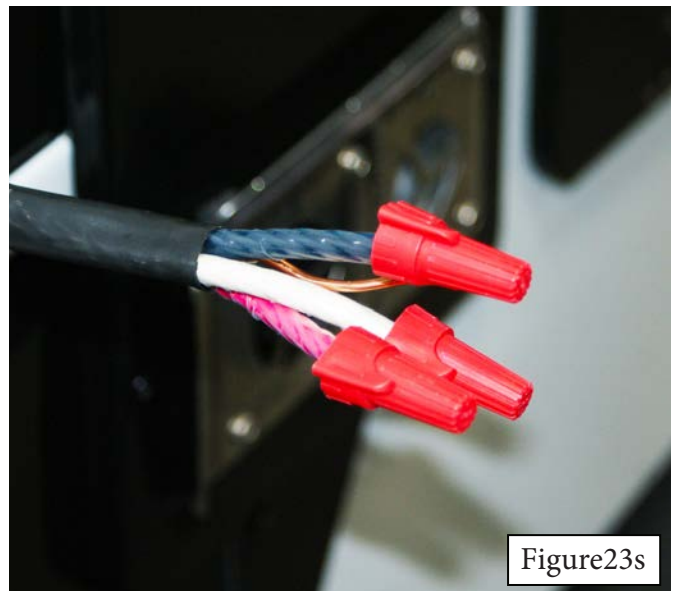
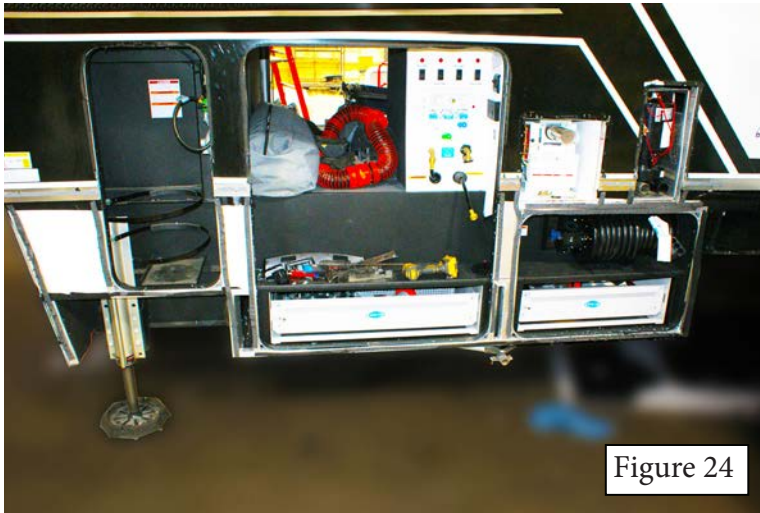
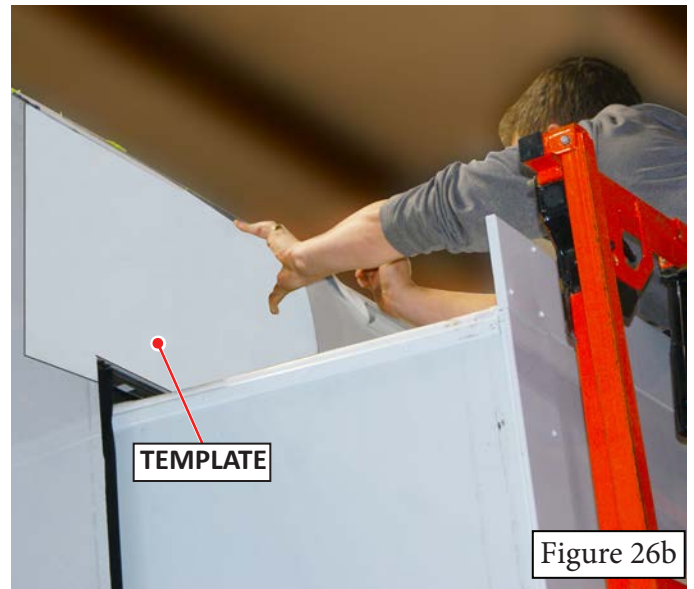
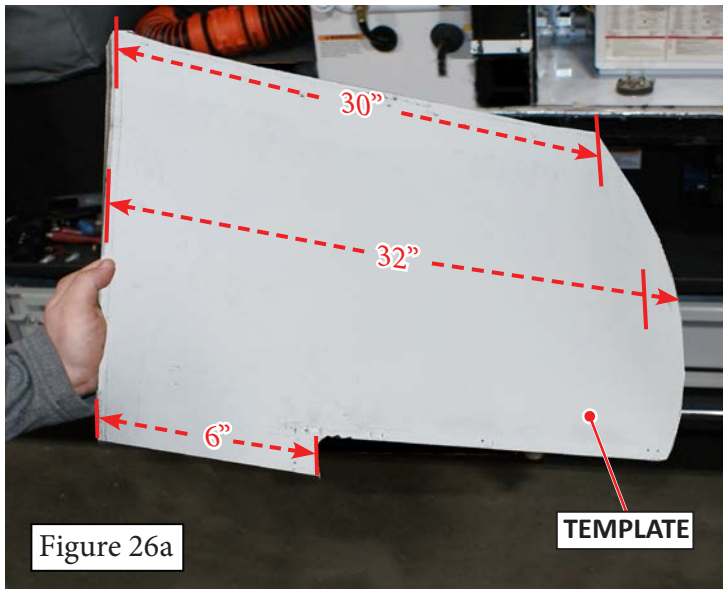

Figure 23s

- Using a screw gun and a #2 square drive bit, remove the skirting along the lower side wall of the unit up to the kitchen slide-out (Figure 24). Some prying may be required to remove the skirting.
- Peel back the edge of the rubber roofing that hangs over the edge of the side wall (Figure 25). Use a plastic prying device (like a Polystick) that will not puncture or otherwise damage the roofing material.



- Use a template and grease pencil to mark the cut line for the fiberglass above the kitchen slide-out (Figure 26a and 26b).



NOTE: Sample measurements are approximate, but work with most floor plans.

**+ NOTICE**

In the following steps, cut **ONLY** the fiberglass sidewall. **DO NOT** cut structure or supports as this may lead to structural damage. There are metal structural components, and sometimes wiring in this area. Cutting deeper than the fiberglass risks damaging anything behind it.

13. Once the fiberglass is marked, use a pneumatic saw to cut the fiberglass along the curved mark (Figure 27a and 27b). **NOTE:** Cut **ONLY** the fiberglass - **DO NOT** cut any structure or support.



Figure 27a

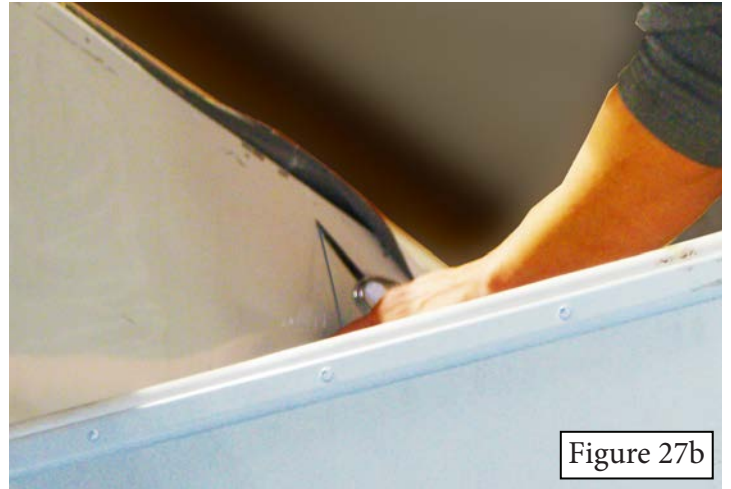

Figure 27b

14. Using prying tools, separate the fiberglass exterior from the aluminum structure (Figure 28a, 28b, 28c, and 28d). Safely pry and pull the exterior fiberglass off of the aluminum frame structure as necessary.



Figure 28a



Figure 28b



Figure 28c



Figure 28d

15. The fiberglass is backed with an azdel material which may separate from the fiberglass and stick to the structure. Once all of the fiberglass has been removed, use a putty knife, oscillating multi-tool or a grinder, remove ALL of the azdel and any residual adhesive from the aluminum wall structure (Figure 29a and 29b).

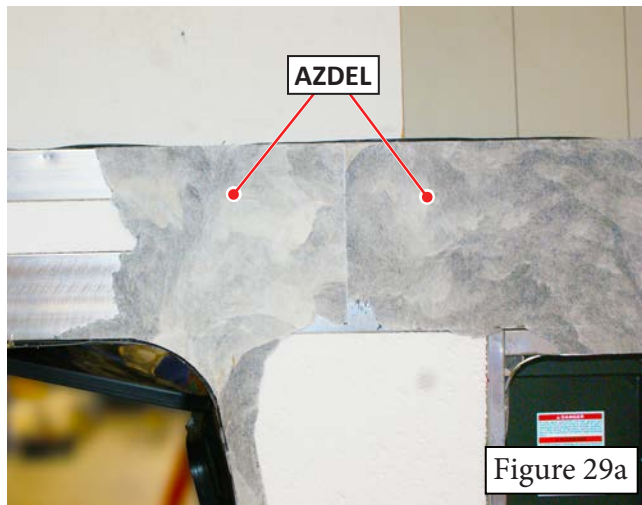

Figure 29a

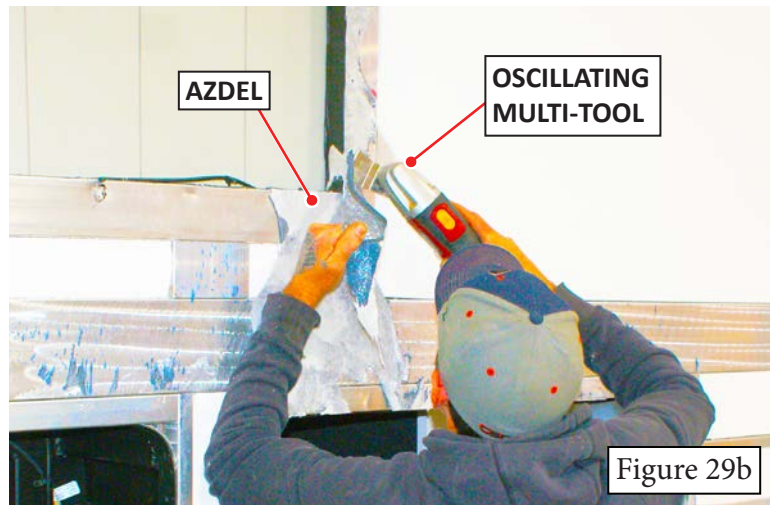

Figure 29b

## SIDEWALL STRUCTURE MODIFICATIONS

### ⚠ CAUTION

**CAUTION: WEAR PROTECTIVE EQUIPMENT** while welding. Burn injury from weld spatter, and blindness can occur from looking at the weld in progress without proper protective equipment. **NEVER** stare into or look directly at the sparks and weld without a welding mask that protects eyes and skin. Wear a protective sleeve to cover clothing and skin. Failure to head these guidelines can result in serious injury, blindness, or death!

### ⚠ CAUTION

**CAUTION:** Install a cover on the slide-out opening into the bedroom, as well as the openings for the storage doors. Remove anything flammable or explosive from the storage compartments, and cover those as well during the welding process. This protects these areas from damage weld spatter while the sidewall structure is being modified. Failure to do so may cause potential damage or fire to these areas, resulting in property damage and possible personal injury.

### + NOTICE

**NOTICE:** All structural modifications performed in this document use aluminum 3" x 1.5" tubes (see below - BRV P/N 100617 for reference). These are cut to size and shape according to the structural prints at the back of the document, and welded into the sidewall structure (Figure 30).

In corners where there are existing braces, add an additional stacked brace (3" x 1.5") on top of the existing brace (Figure 31).

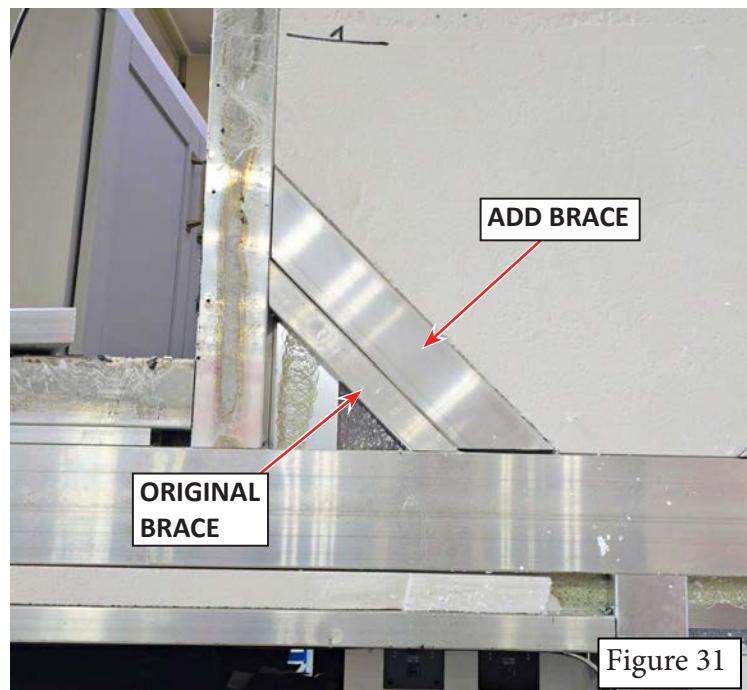
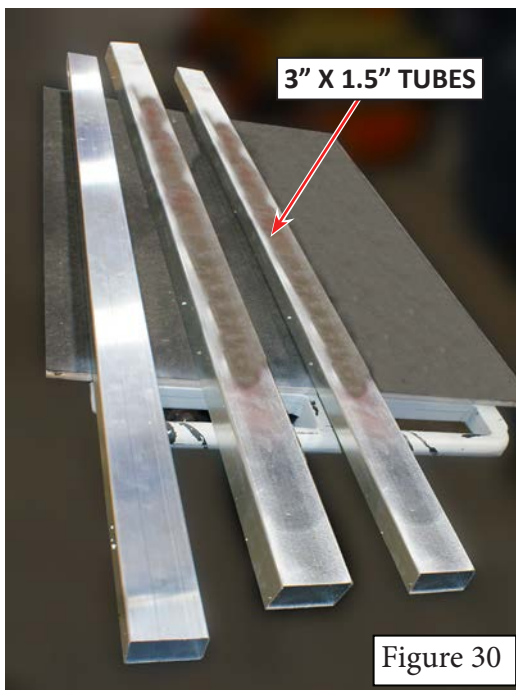

**+ NOTICE**

**NOTICE:** It is **IMPORTANT** to place the pinbox of the RV in a tripod or stand before beginning structural modifications (Figure 32). This simulates towing to align and stress the structure as it would see when traveling. The tripod (or stand) is only required during sidewall structure modifications.



Figure 32

1. Mark the sidewall structure for additional bracing. Starting at the edge of the kitchen slide-out, measure as indicated on the attached prints and mark the foam insulation for installation of braces. Vertical braces (when added) are typically installed on 48" centers. **NOTE:** On the prints **RED** means **ADD** this reinforcement, **YELLOW** means **ADD IF NOT ALREADY THERE** (Figure 33 - this photo is an example of the structural modifications - actual prints are attached to the end of this document).

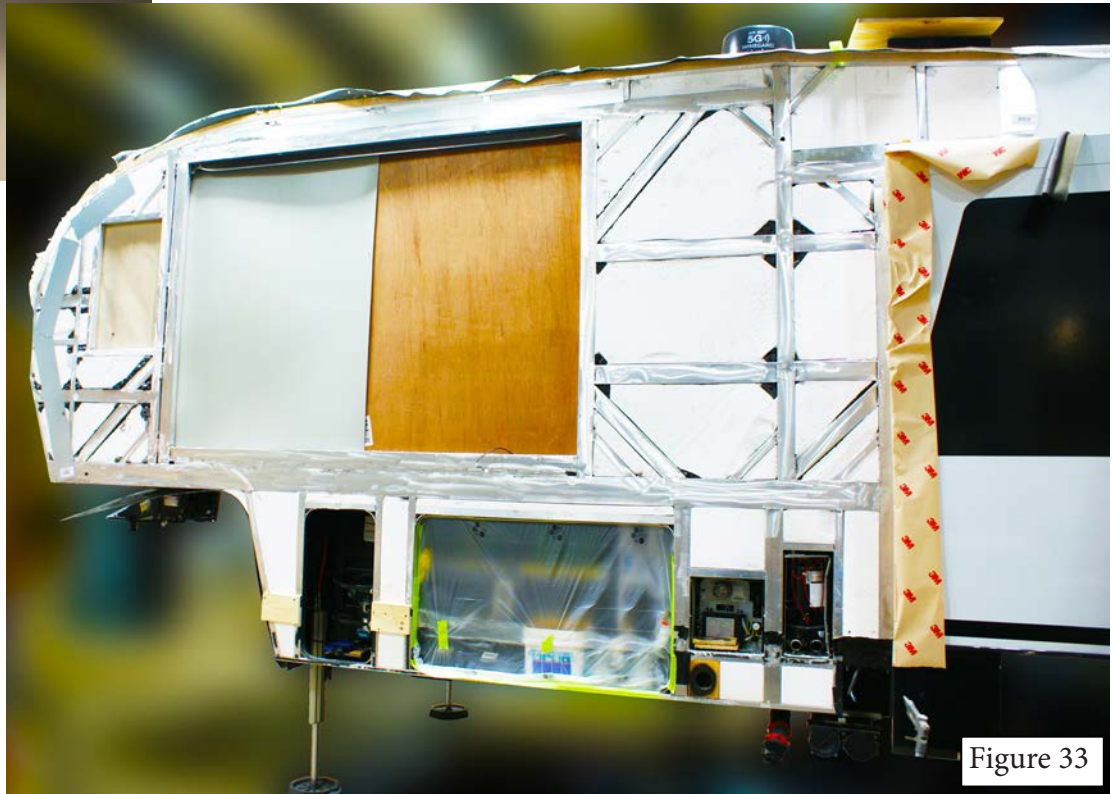

Figure 33

- Using a magic marker pen (or equivalent) and a 2" x 6" aluminum brace tubes to lay out the modifications to the sidewall (Figure 34).
- Once the vertical, horizontal and diagonal structure bracing marks are laid out on the sidewall structure, use a razor knife to cut along the lines, then use a 6" putty knife to chisel the styrofoam out for installation of the braces (Figure 35a and 33b).



Figure 34



Figure 35a

- Cut the Styrofoam out of each corner and joint where the original structure was built. Inspect for broken welds (Figure 36a and 36b). Inspect ALL original welds on the exposed sidewall and mark for repair as needed.

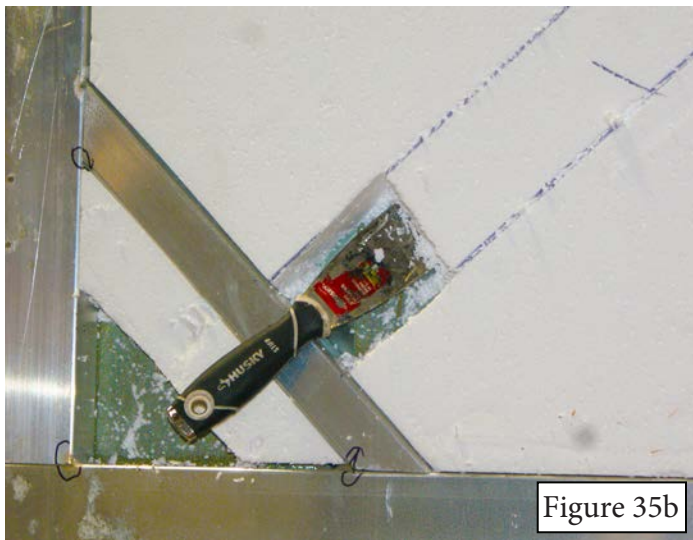

Figure 35b

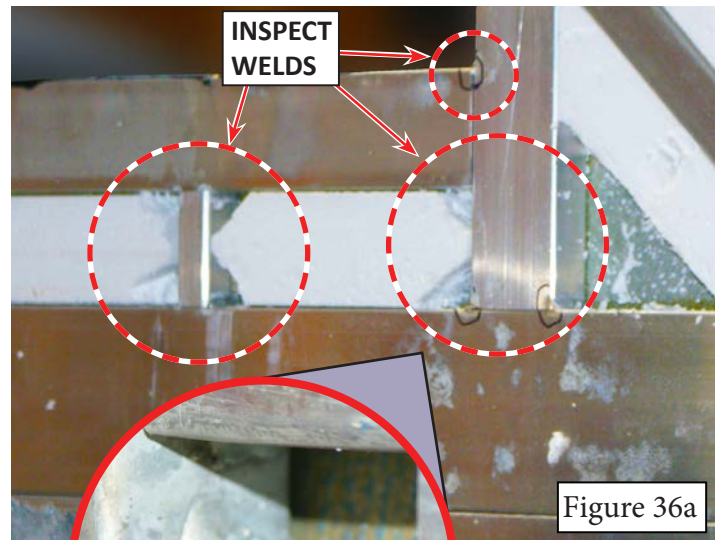

Figure 36a

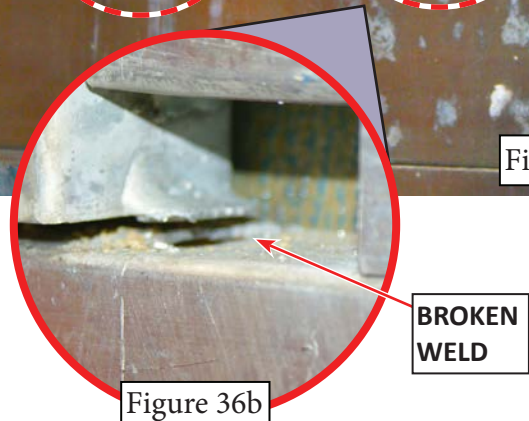
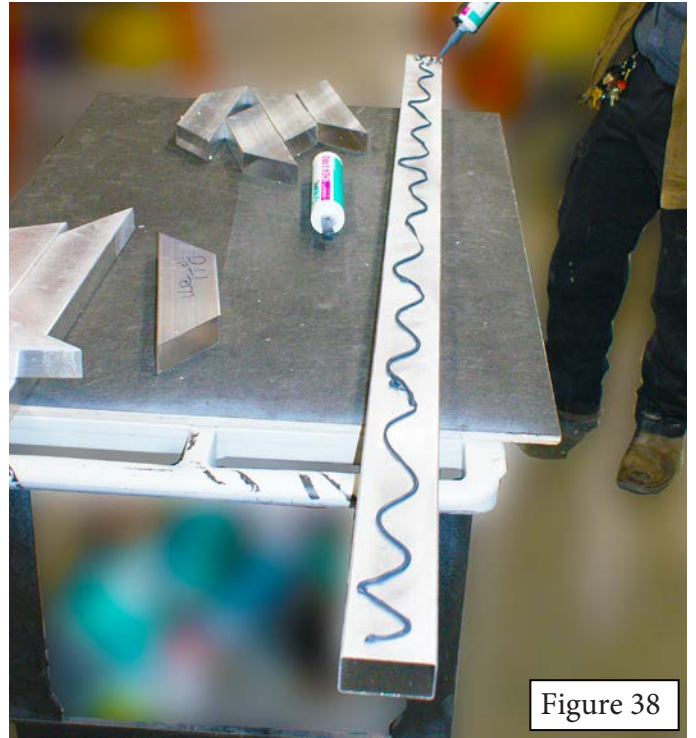
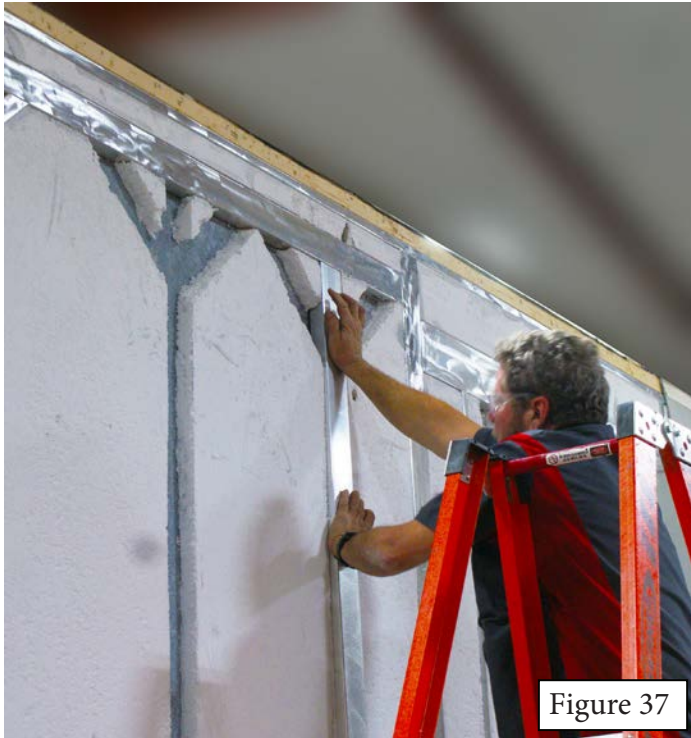
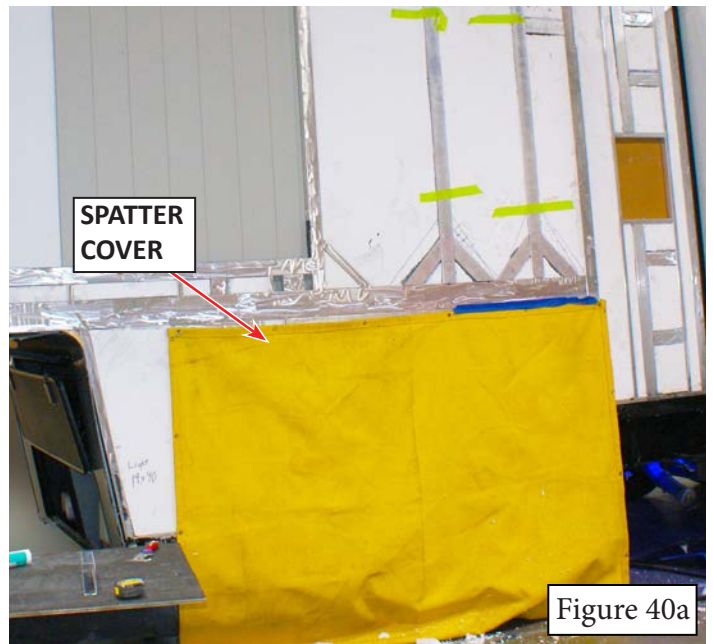
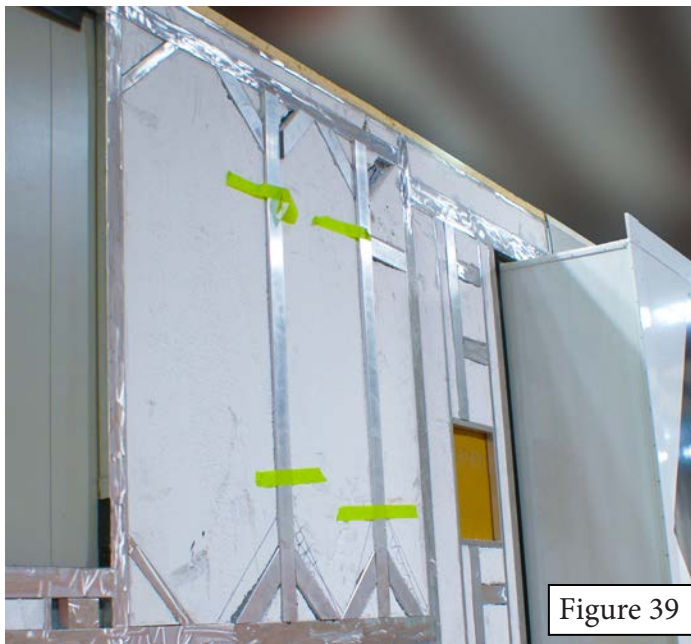

Figure 36b

5. Cut the braces to size for each opening and test fit (Figure 37).
6. Install the bracing in the sidewall using Chem X adhesive (P/N 100650) (Figure 38).



7. Tape the braces in place if necessary to hold them while the Chem X sets - typically overnight (Figure 39).
8. Cover any openings and finished surfaces to prevent weld spatter from causing damage (Figures 40a and 40b).



9. Prepare the structure for welding by installing a bolt on the sidewall structure for the welder (Figure 41). Attach the lead from the welder to this point.



10. When the braces are all in position, begin welding them to the sidewall structure (Figure 42a, 42b, 42c, and 42d). Repair any original welds that were broken at this time as well.





Figure 42c

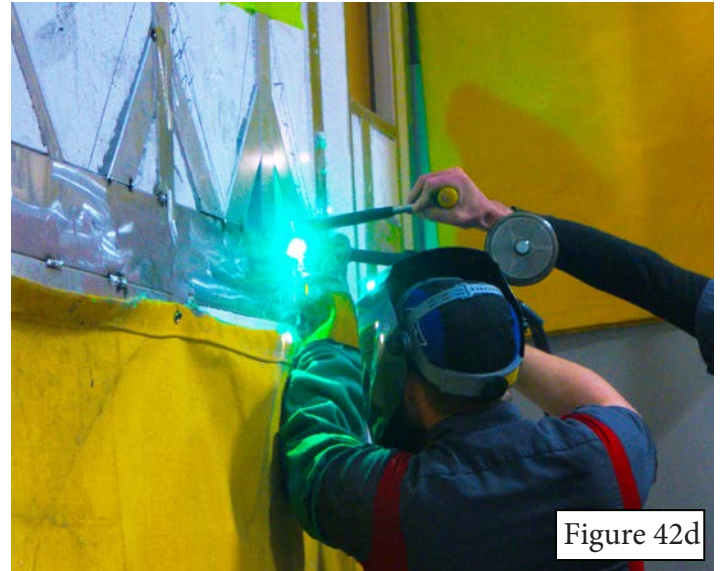

Figure 42d

11. When all the welds are complete, inspect them thoroughly for gaps and holes that may have occurred during the process (Figure 43).
12. When satisfied of the quality of the welds, use a power grinder and a T-29 aluminum disc (BRV P/N 111955 for reference) to grind the welds flush (Figure 44a and 44b).

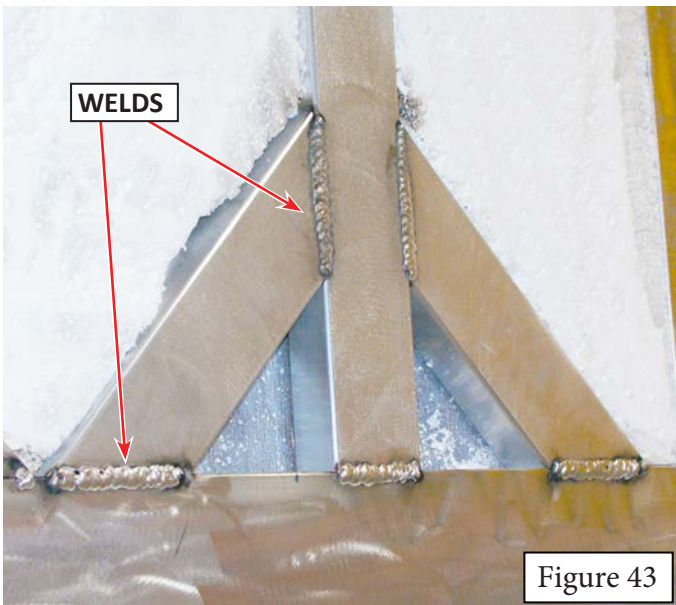

Figure 43



Figure 44a



Figure 44b

13. Once all of the welds have been ground flush, give each weld a final inspection for gaps, holes or breaks (Figure 45- sample - all welds should be flush like this example).
14. Use expanding foam to fill the gaps and voids in the styrofoam insulation that were created to inspect the original welds (Figure 46).

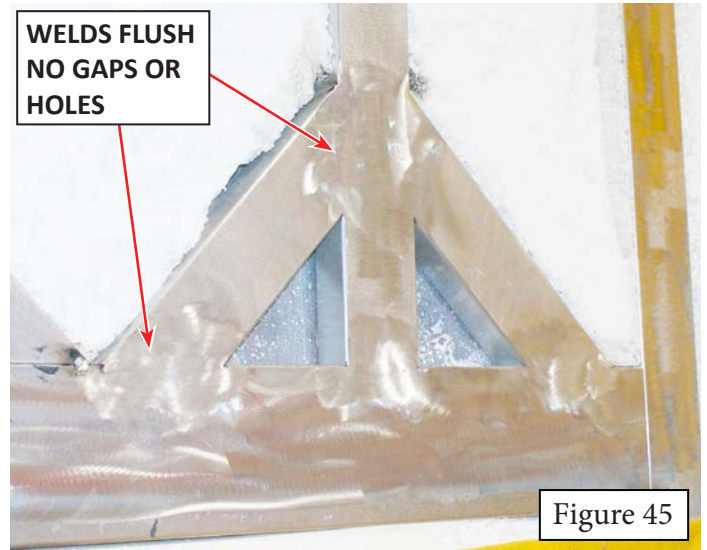
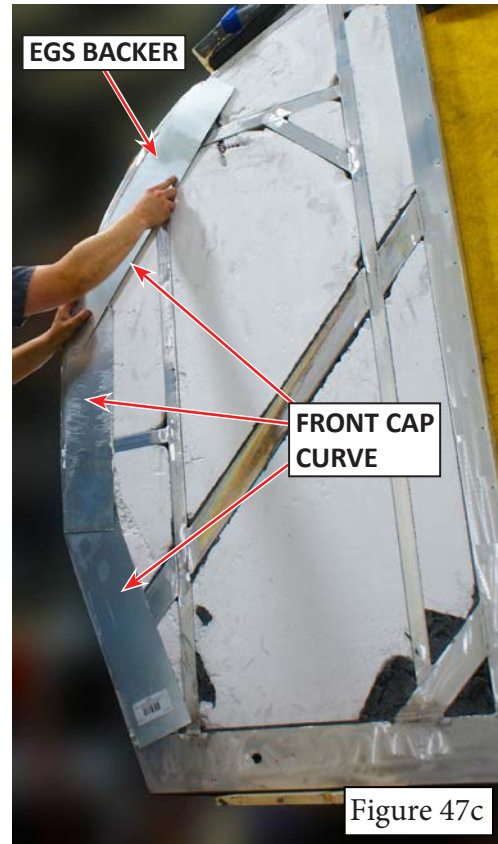
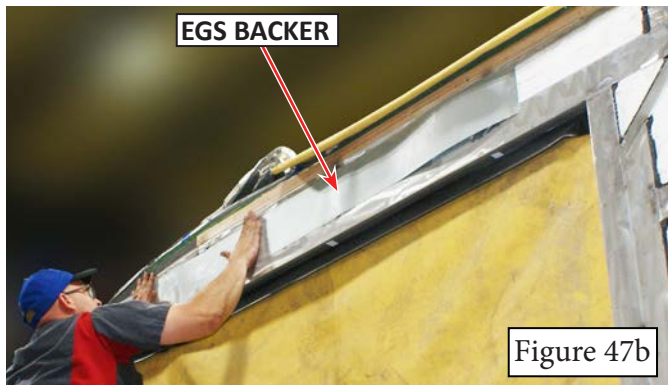

Figure 45



Figure 46

15. Use CHEM X (P/N 100650) or similar adhesive to install EGS (Electro Galvanized Steel) backer panel covering the styrofoam above the slide-out (Figure 47a and 47b). Tuck the right end behind the existing fiberglass at the curved cut above the slide-out, and press it flat into the opening. Also install EGS along the curved edge of the front structure where the front cap will attach (Figure 47c).



16. Once all holes are filled, use a power grinder and a T-29 aluminum disc (BRV P/N 111955 for reference) to scuff all of the aluminum surfaces where they will contact adhesives to improve adhesion (Figure 48a and 48b).



## FIBERGLASS WALL INSTALLATION

1. With the new sidewall layed flat, use the original template used to mark the cuts for the slide-out opening, and the curved end at the top that mates to the existing sidewall over the kitchen slide-out. Use a circular saw with a fine tooth blade to cut the straight opening for the slide-out (Figure 49).

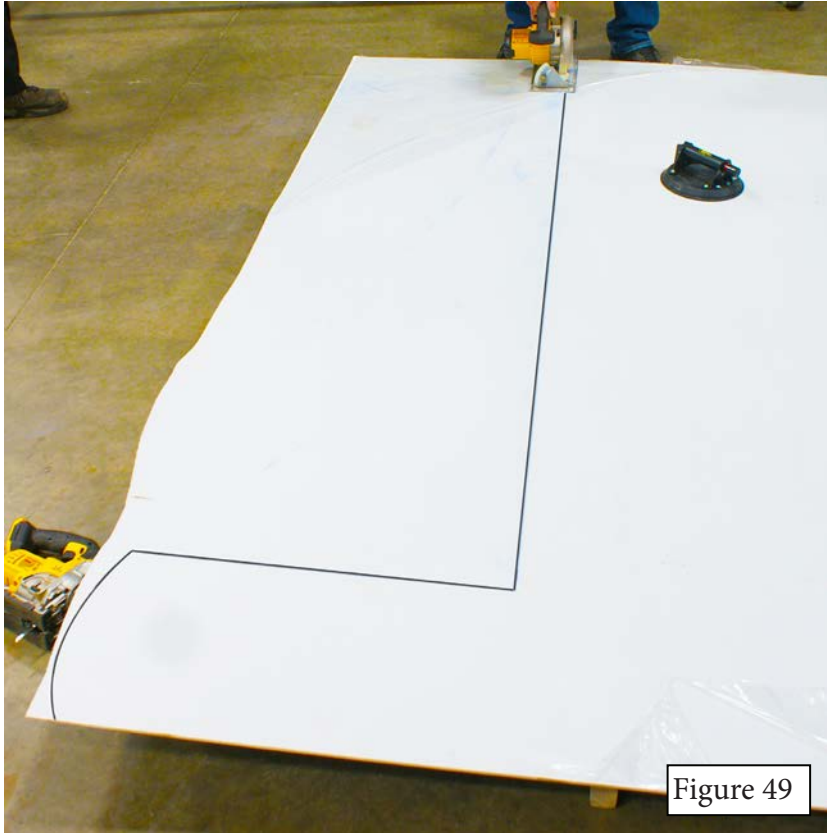

2. Use a saber saw with a fine tooth blade to cut the curved section that goes over the kitchen slide-out (Figure 50).

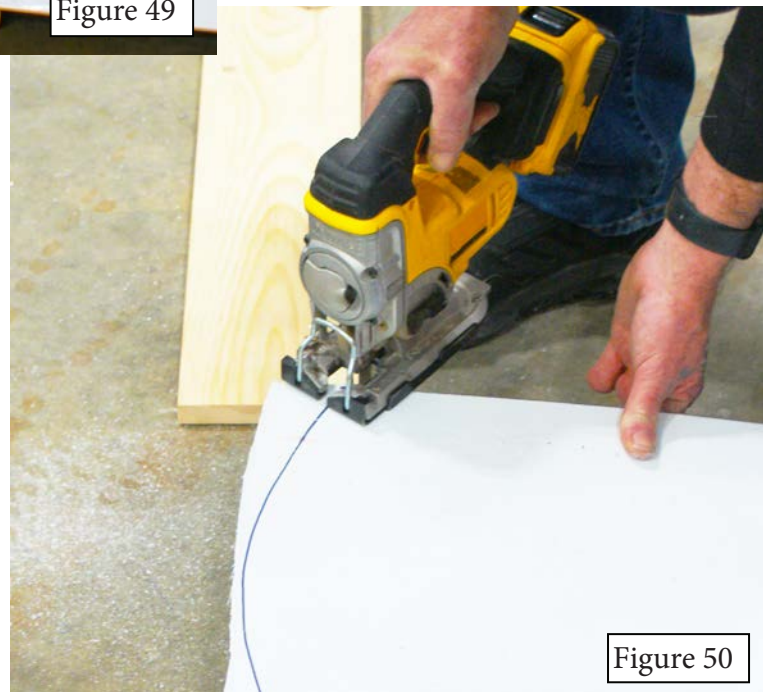

3. Thoroughly clean the mating surfaces of the aluminum sidewall structure using Alodine (P/N 101444) and clean shop rags or microfiber towels (process not shown). Allow to thoroughly dry before applying adhesives. Rotate or replace wiping clothes regularly during the cleaning process.
4. Screw two (2) 2”X4” boards to the sidewall area 104” (measured from the top of the roof edge) to rest the sidewall on when installing it (Figure 51). These are TEMPORARY supports for the sidewall during installation.

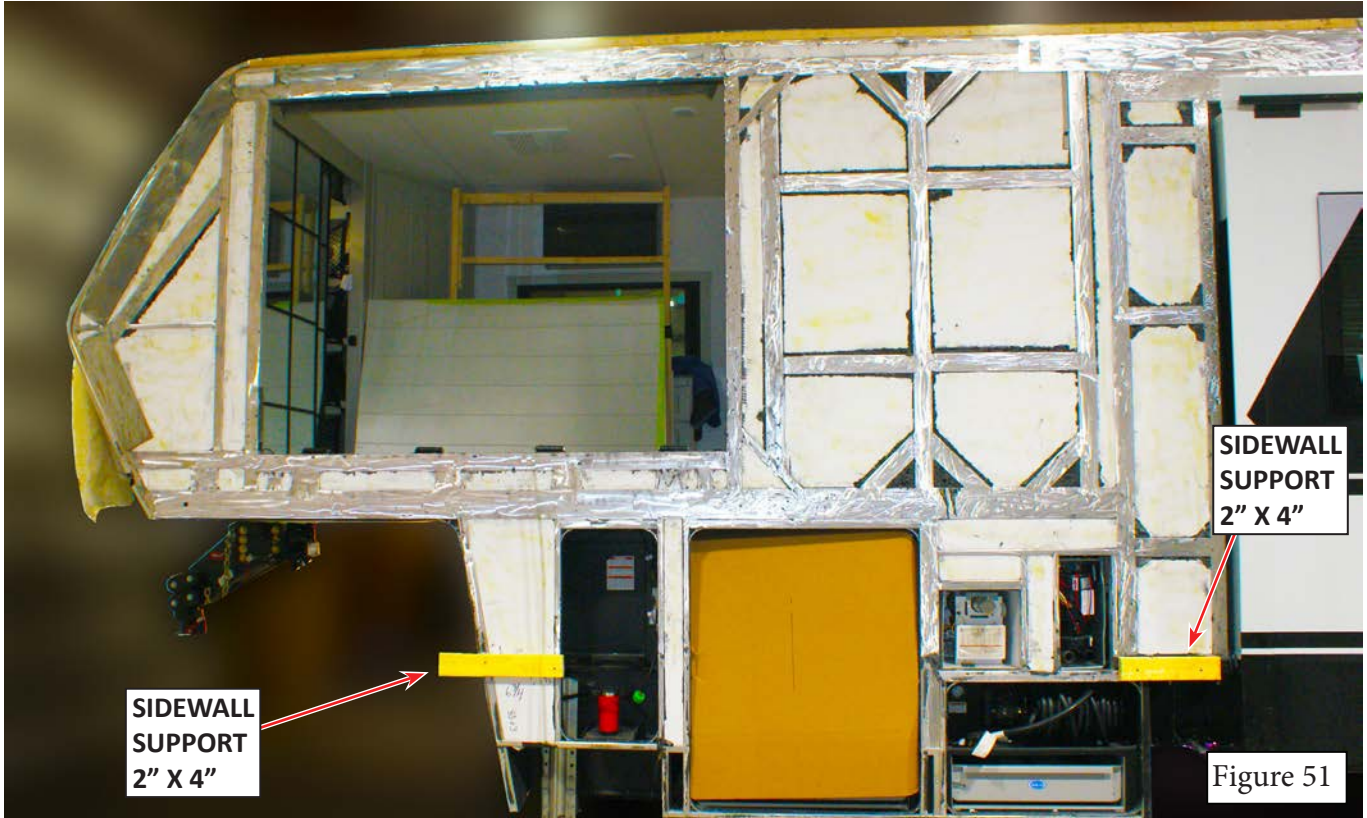

5. Lift the sidewall into position to test fit (Figure 52a). If the shop does not have a hoist, at least 4 technicians are required. Place it on the 2”X4” support rests, and make sure it covers everything, and the cut curved joint above the kitchen slide-out mates properly to the curved cut in the existing wall (Figure 52b).



**+ NOTICE**

The adhesive being used - ECO-TITE hybrid adhesive (P/N 117553) - has a “Skin Over” flexible set up time of 30 minutes on initial application, and a curing time of 24 hours. Refer to the manufacturer’s instructions for safety and clean-up procedures. The sidewall needs to be in position and being secured within 30 minutes of application of adhesive.

Adhesive should be applied liberally, but not excessively. Eleven (11) tubes of ECO-TITE typically provides sufficient coverage for twenty (20) linear feet of wall section. Windows, slide-outs, storage doors and appliance openings may be different from one floorplan to another, but in most applications 11 tubes per 20 linear feet of wall provides strong adhesion.

**BE CERTAIN THE ADHESIVE IS APPLIED TO ALL METAL AND STYROFOAM SURFACES AS SHOWN.**

6. Once the test fit is confirmed, pull the sidewall fiberglass down and set carefully aside (not shown).
7. Using a pneumatic gun, apply ECO-TITE hybrid adhesive sealant (P/N 117553) on ALL aluminum structure AND Styrofoam surfaces that will contact the new exterior wall (Figure 53a, 53b, 53c, and 53d, and 53e on page 44 and 45).



Figure 53a



Figure 53b



Figure 53c



8. Be certain adhesive is applied to all mating surfaces for maximum contact and adhesion (Figure 54).



**+ NOTICE**

**NOTICE:** The adhesive used to hold the fiberglass to the sidewall structure is **PRESSURE ACTIVATED**, and must have the proper pressure applied to adhere to and cure on both surfaces. The following instructions outline the procedure to apply sufficient pressure to activate the adhesive.

Prepare six (6) 4'X8' Sheets of 3/4" finished plywood by covering one side in felt (Figure 55). These will be used to secure the wall at the top and bottom for curing. For easier installation at the front of the unit, trim one of the panels to the contour of the front cap opening (as seen in Figure 61b, page 50),

To press the wall firmly for the extended curing period (24 hours), have eight (8) 1/4"X2"X2" angle, in 12' lengths ready (Figure 62a, page 50). Additional pressure is applied to the sidewall while the adhesive is curing by inserting shims between the angle pieces and the plywood panels (Figure 64a and 64b, page 51).

To expedite the final steps of the fiberglass installation, prepare these items in advance, and have them ready before applying the adhesive to the sidewall structure.



**FELT COVERED  
PLYWOOD**

**Figure 55**

## FIBERGLASS WALL INSTALLATION

1. Lift the sidewall into position and rest on top of the 2"X4" supports. slide the wall into position on these supports **BEFORE** pressing the fiberglass back onto the adhesive (Figure 56).

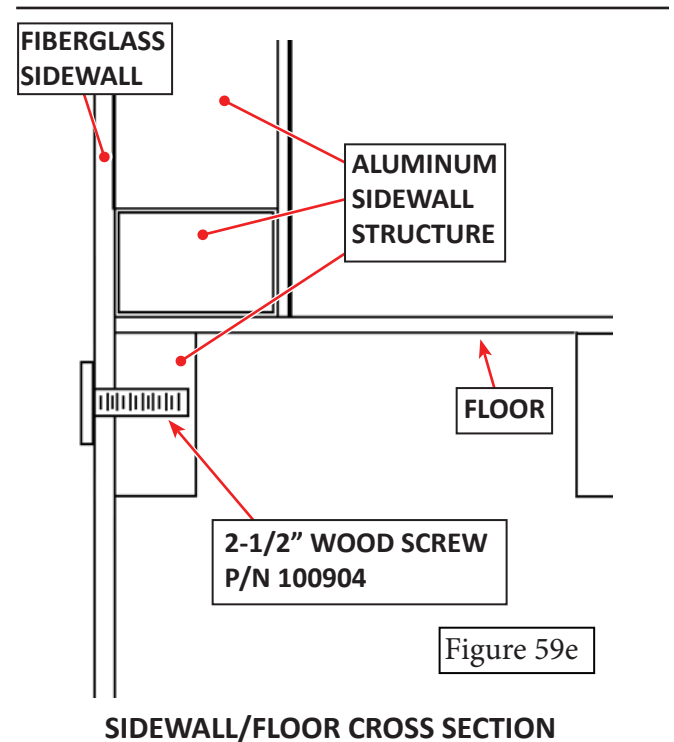
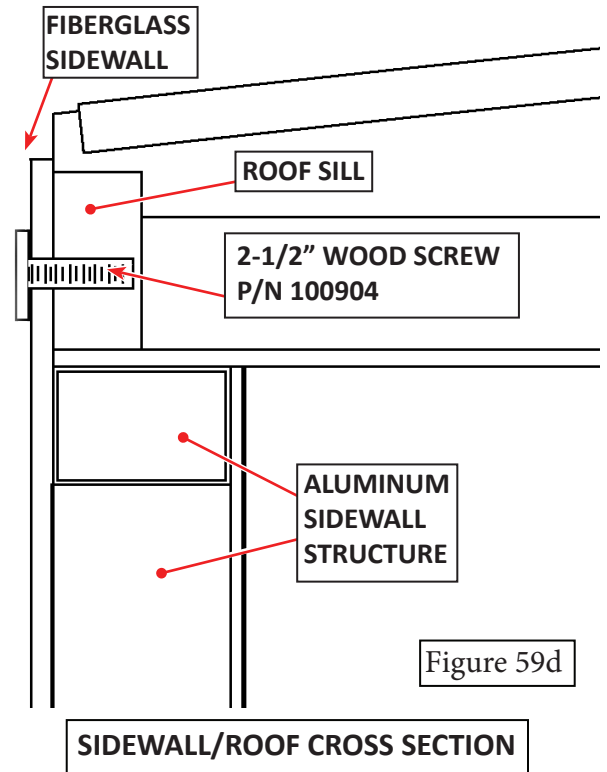

**Figure 56**

2. Once the sidewall is positioned properly, press the sidewall firmly against the adhesive on the sidewall structure (Figure 57 and Figure 58).



- Using a screw gun with a #2 square drive bit, begin attaching the fiberglass sidewall to the roof structure using 2-1/2" wood screws (P/N 100904) - fasten the top of the fiberglass to the wooden roof sill (Figure 59a, 59b and 59d), and the bottom of the fiberglass to the wall structure (Figure 59c and 59e). Continue to apply pressure to the fiberglass as it is being attached to the body structure (not shown).



4. Once the new fiberglass is secure around the perimeter of the wall structure, use a hand held power saw or router to begin routing or cutting off the overlap areas (front cap area, baggage doors, etc.) (Figures 60a, and 60b), Route out the slide-out opening and any window openings in the fiberglass (Figure 60c).

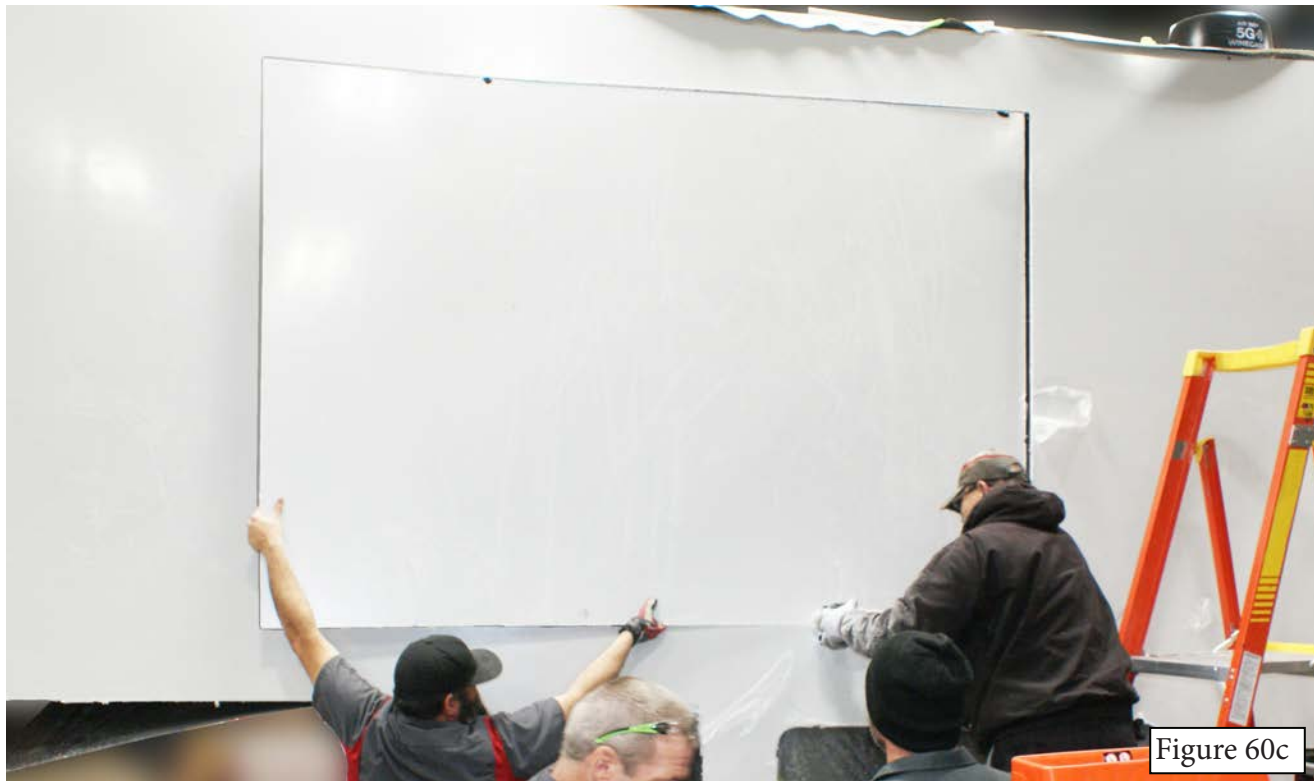

**+ NOTICE**

**NOTICE:** It is often easier to hang the plywood covers if they are cut for the front angled section of the sidewall where the front cap attaches, as well as where the storage compartment doors are located.

- Using a screw gun and #2 square drive bit, install the felt covered plywood panels over the fiberglass using 2-1/2" wood screws (P/N 100904) (Figures 61a and 61b). Secure them at the top into the roof sill, and at the bottom into the exposed structure BELOW the sidewall.



- Use a screw gun with a #2 square drive bit to secure the L-brackets over the plywood panels using 3" #10 wood screws (P/N 104187) (Figure 62a). Use two (2) L-brackets to secure the panels as shown (Figure 62a). Secure at the top and bottom.
- Use clamps to secure the openings for the slide-out, basement doors, and the front cap area (Figures 62b and Page 49, Figure 65). Where possible, place clamps at a minimum of 12" apart, closer where applicable.

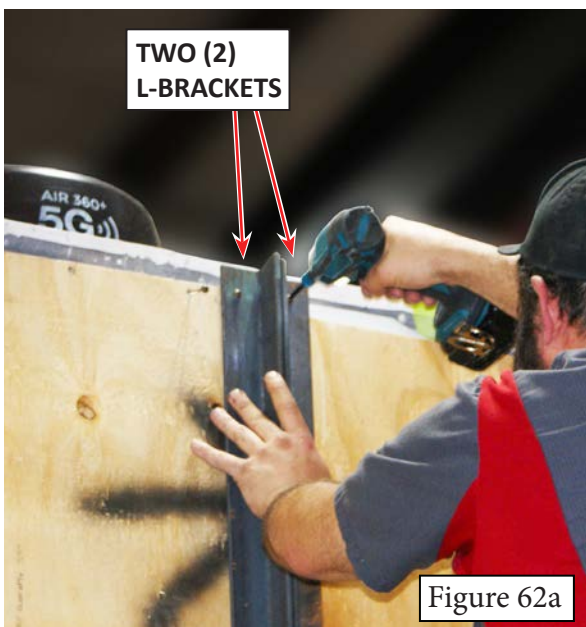

8. Once the front alcove is clear of excess fiberglass, attach the bottom of the front L-bracket to the pin box with a ratchet strap and pull it tight to compress the sidewall in that area (Figure 63).

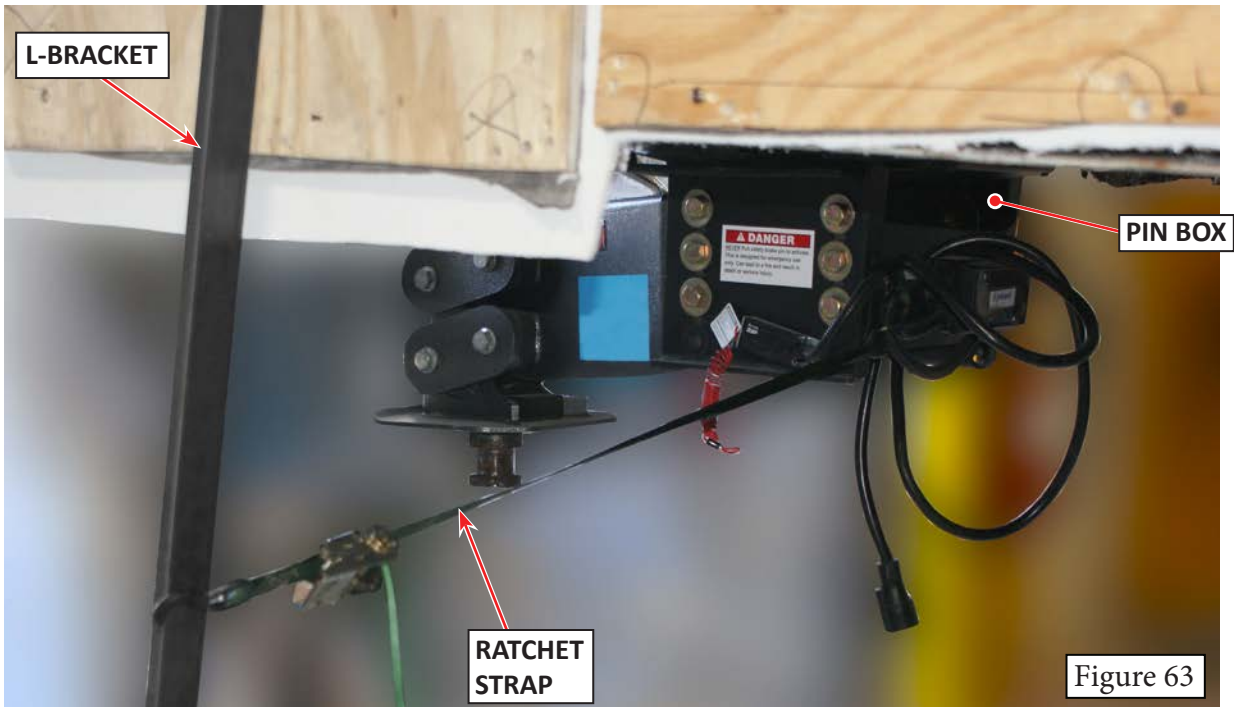

9. Insert shims between the L-brackets and plywood panels to provide additional pressure on the sidewall to further activate the adhesive (Figure 64a and 64b).

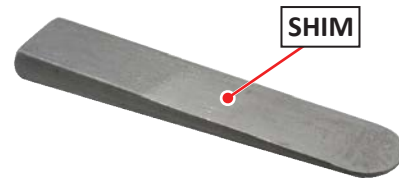

**+ NOTICE**

The cure time for the supplied adhesive is 24 hours. **DO NOT** remove bracing until cure time has passed.

**FIBERGLASS INSTALLED,  
CLAMPED, BRACED AND  
SHIMMED FOR CURING  
(FIGURE 65)**

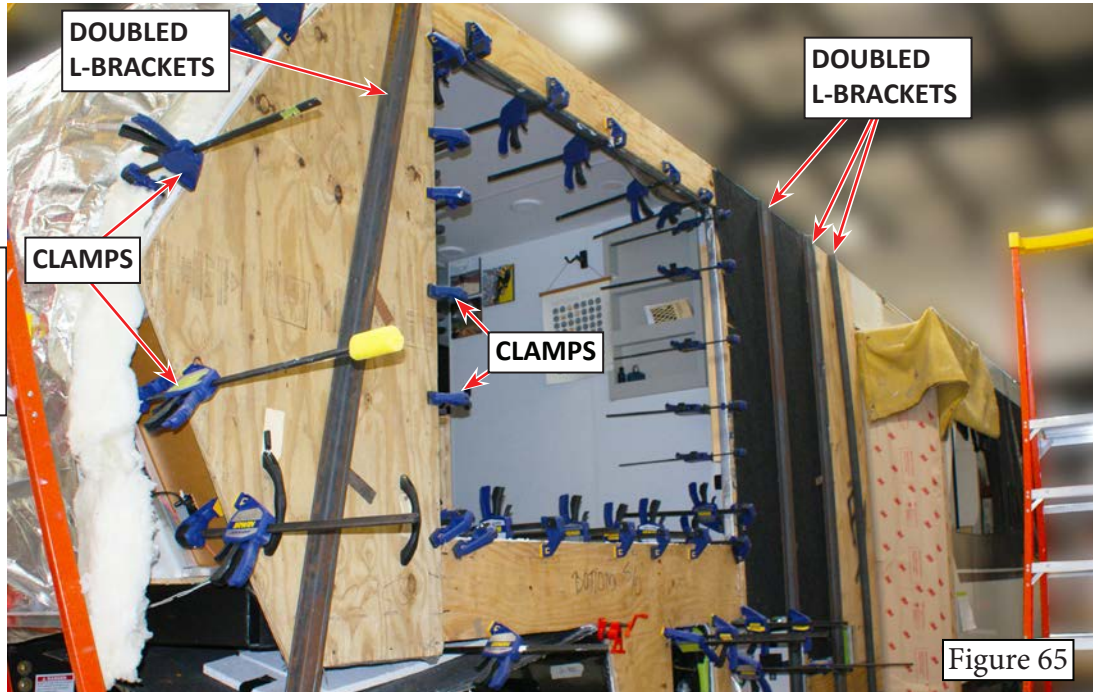

**REASSEMBLY AND PREP FOR PAINT**

1. Once the adhesive has had sufficient time to cure, remove all of the L-brackets and plywood bracing from the side of the RV (not shown).

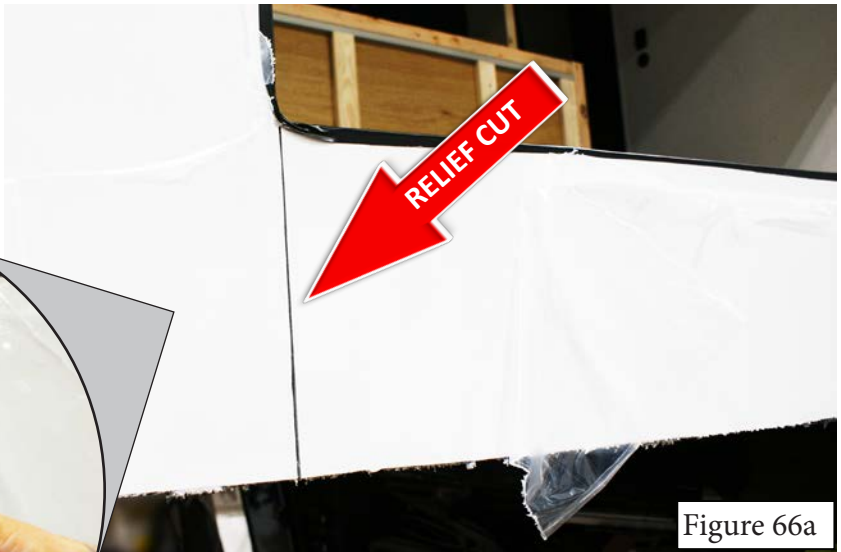

2. Using a hand held mini-saw, make a vertical relief cut at the front lower corner of the slide-out opening. Cut 3/16" deep to ensure ONLY the skin and backer are cut (full material depth is approximately 0.250" or 6.35mm) DO NOT cut into the metal sidewall structure under the skin. (Figure 66a and 66b).

## REASSEMBLY AND PREP FOR PAINT (CONT'D)

3. In preparation for fiberglass work and final application of paint and graphics, the following steps need to be performed. Refer to the prior removal instructions if there are questions about fit, measurements or fasteners.
  - Installation of the front cap - connect all wiring, then tuck the roof membrane along the back edge and sides of the cap prior to securing the cap in place. Install trim and seals prior to paint.
  - The roof membrane can be rolled over onto the sidewall, but should not be secured. DO NOT install the roof rail at this time. The roof rail must be loose for paint and fiberglass work, and is to be installed after the unit is painted.
  - Installation of the bedroom slide-out - all interior and exterior components of the bedroom slide-out should be installed, adjusted, and working properly when the unit goes to paint. The room should operate as normal, traveling completely in and out when sent to paint.
  - Installation of cargo and appliance doors - these should be secure, adjusted for proper operation and locking, sealed, and ready for paint prior to sending to the paint shop.

### **⚠ WARNING**

**WARNING** - Before installing the shore power cord input connector, make sure the RV is unplugged from ALL power sources (including shore power) and all disconnects are turned "OFF". Failure to do so can result in death, serious personal injury, severe product and/or property damage.

1. Install the shore power cord receptacle:
  - Access the original mounting hole in the structure behind the new skin (Figure 67a). Use a screw gun with 3/16" drill bit to drill a hole in the new sidewall skin where the original hole is in the structure (Figure 67b).
  - On the OUTSIDE of the new skin, use a hand held router inserted in the previously drilled 3/16" hole to route out the opening for the shore power cord connector (Figure 68).

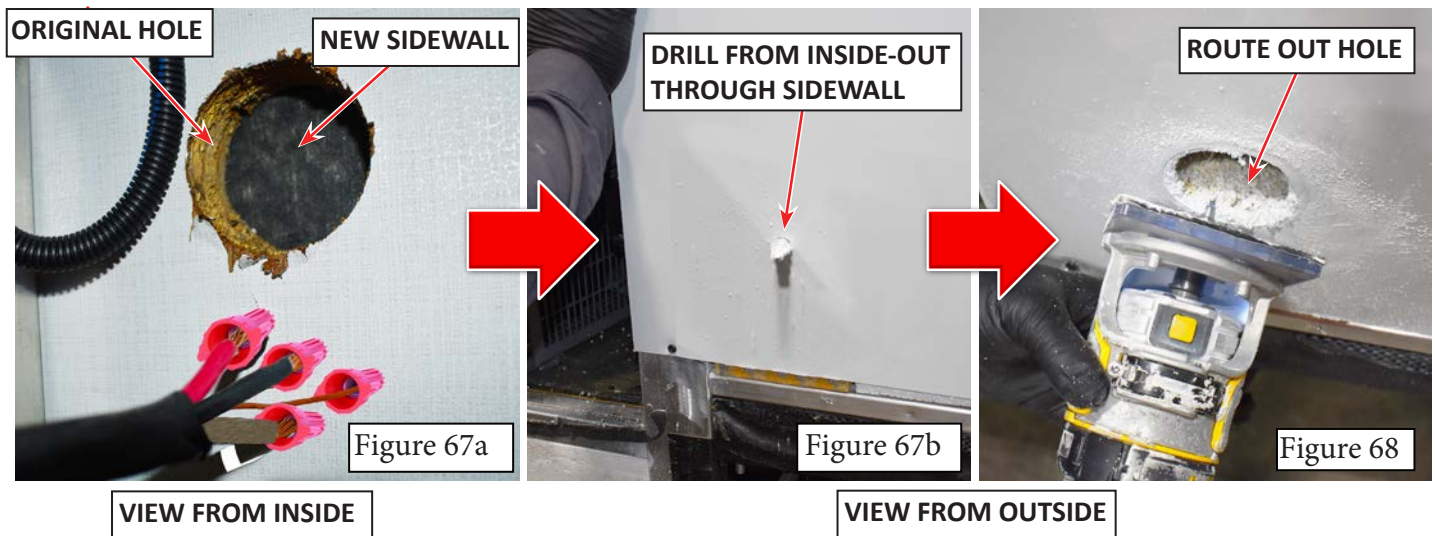

- Access the electrical cord and pass it through the new opening (Figure 69).
- Remove the caps covering the ends of the wires. Insert the wires into the appropriate color coded holes in the shore power cord input connector (Figure 70a). BE CERTAIN the wires are properly seated and positioned as illustrated (Figure 70b).

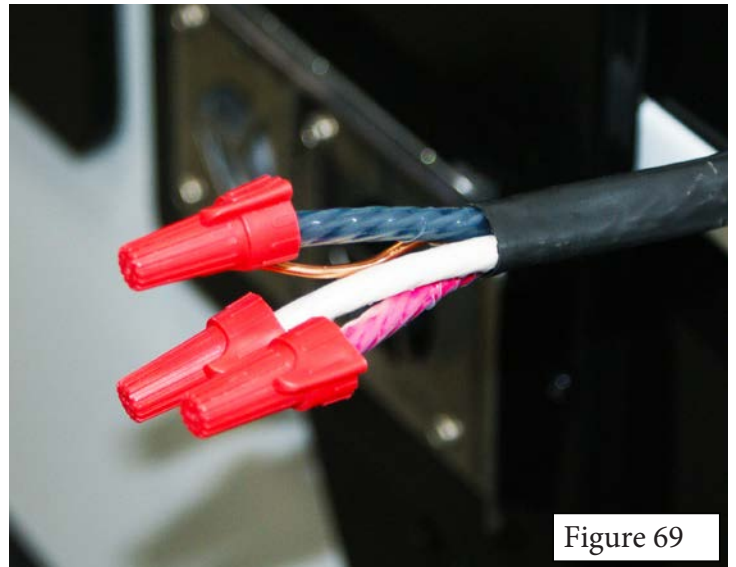

Figure 69

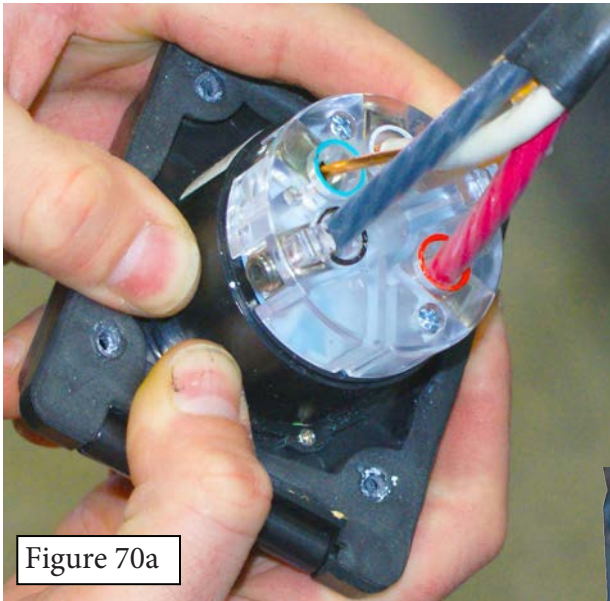
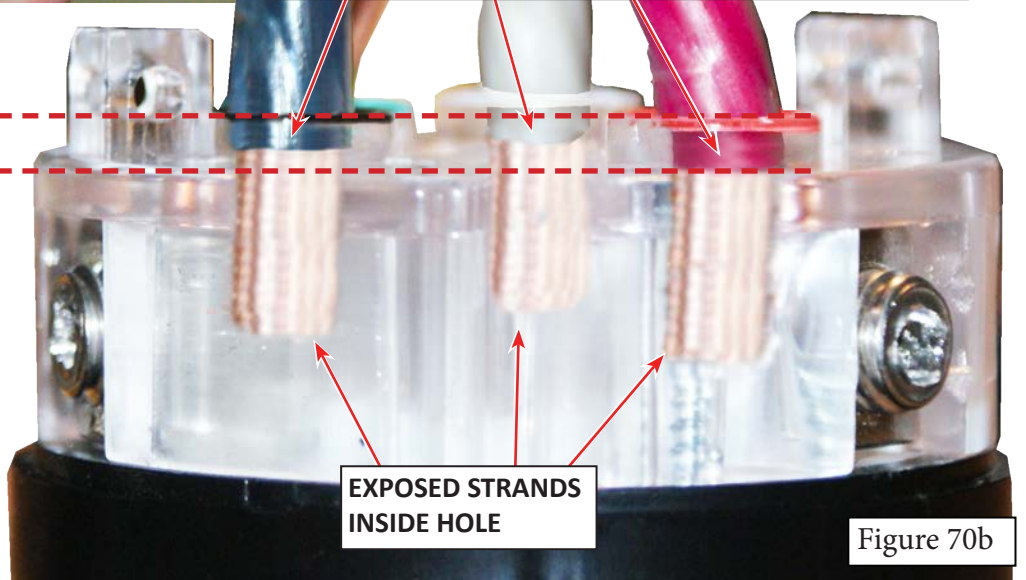

Figure 70a

**INSULATION ON WIRING SHOULD BE STRIPPED BACK 3/4" FROM THE END OF THE WIRE, AND COPPER SHOULD BE BOTTOMED OUT IN THE LUG. THE INSULATION SHOULD EXTEND BELOW THE TOP EDGE OF THE LUG HOLE, BUT MUST NOT EXTEND INTO THE TERMINAL.**

**NO EXPOSED STRANDS ABOVE THIS LINE**

**NO INSULATION BELOW THIS LINE**



**EXPOSED STRANDS INSIDE HOLE**

Figure 70b

- Once satisfied all connections are correct and input connection housing is undamaged, use a torquing tool (that measures in in-lbs.) and a #2 square drive bit to torque **ALL CONNECTIONS** to the appropriate torque for the style of inlet used (Figure 71a and 71b):
  - Furrion: 25 in-lbs. - Flat Head bit
  - Epicord: 35 in-lbs. - Flat Heat, Phillips Head or Square Drive bit
  - Epicord: 75 in-lbs. (units produced **AFTER 1/1/2026**). Square Drive bit
  - See Figures 72a and 72b for differences.

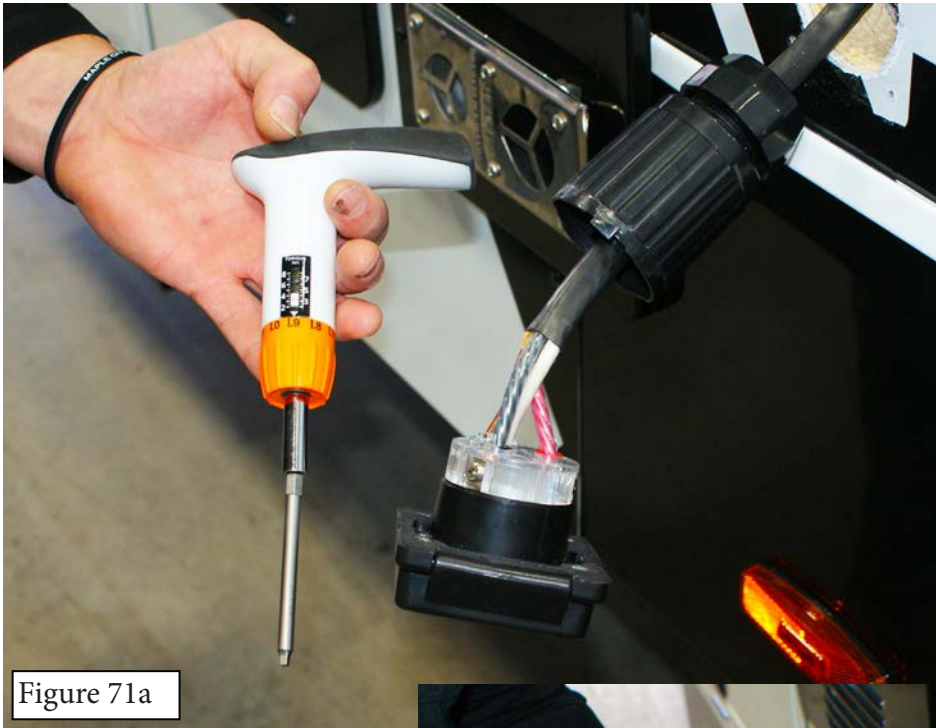

Figure 71a

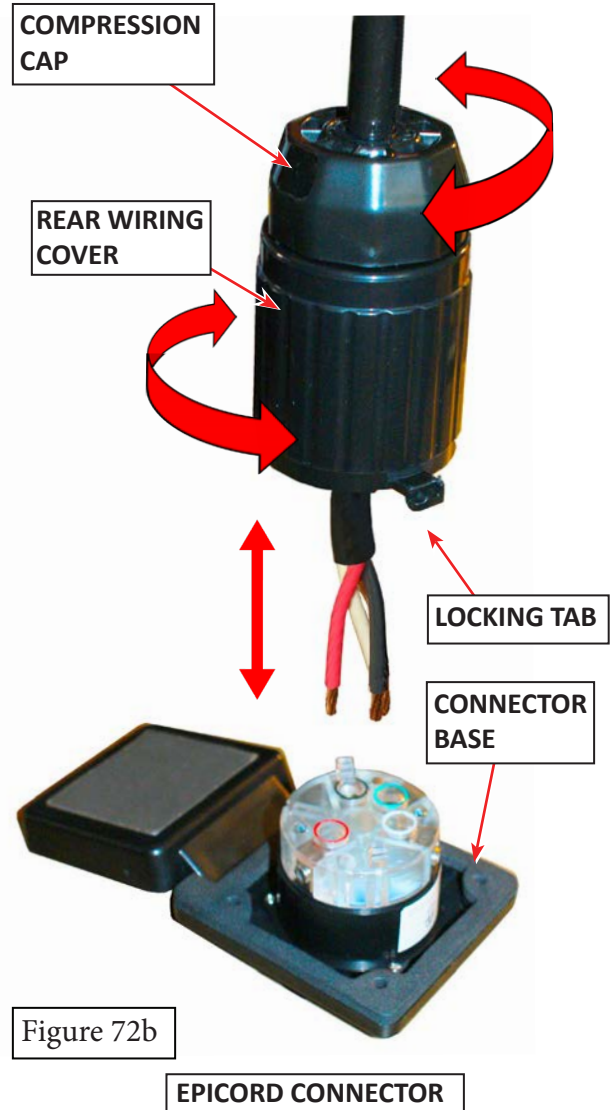
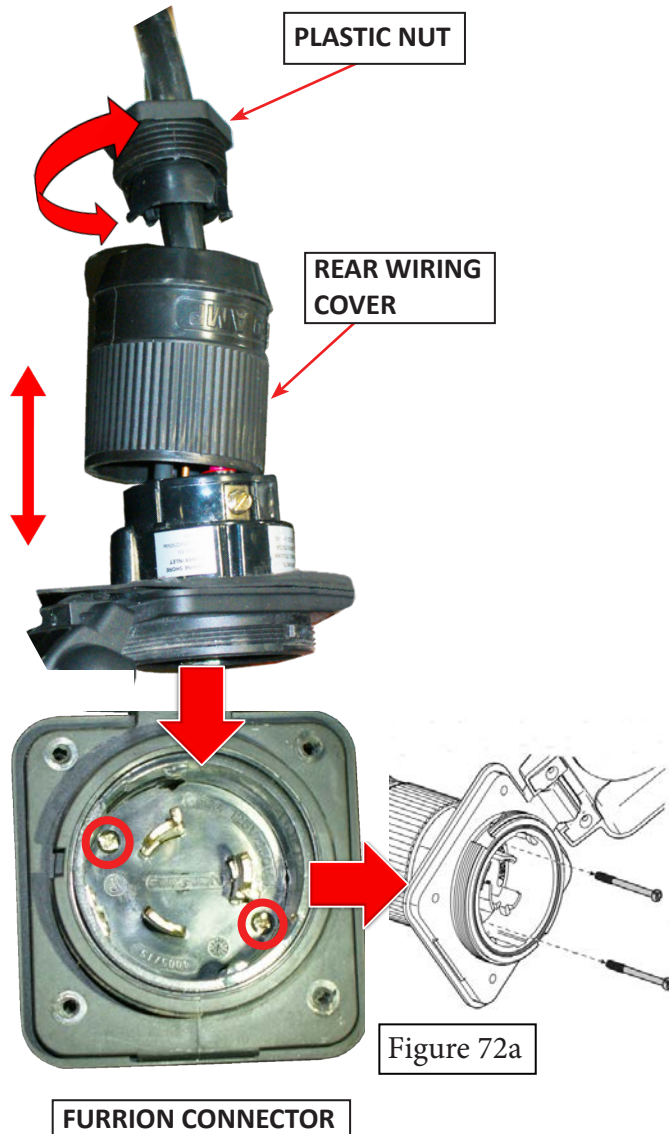

Figure 71b

**+ NOTICE**

**NOTICE:** The following steps involve installing the two (2) different shore power cord connector wiring covers Brinkley uses: installation and removal are virutally identical, but there are slight differences in the way the back covers are attached that affect how you reinstall them over the wire connections.

- The Furrion connector uses two screws that pass thugh the front connection opening to hold the rear wiring cover in place (Figure 72a). Install the rear cover over the wires and seat it again to the back of the connector base. Use a **HAND SCREWDRIVER with a #1 Phillips bit** to install the two screws through the front of the connector base to secure the wiring cover. Install and hand tighten the plastic nut to snug into the wiring cover.
- The Epicord connector uses a “twist-lock” action to lock the rear wiring cover to the back of the connector base (Figure 72b). Slide the rear wiring cover down over the wires and against the back of the connector base. Twist the rear wiring cover clockwise to lock into the base. Install the compression cap onto the rear wiring cover and twist it clockwise until snug to seal off the wiring inside the rear wiring cover. NOTE that Epicord connectors **BEFORE 1/1/2026** also use two small screws passing through the connector base to further lock the rear wire cover in place (just as with the Furrion connector).



- Install the wire cover onto the shore power cord input receptical. Where applicable, use a hand held flat head scew driver to secure the wire cover to the shore power cord connector base with the original screws (Furrion Figure 72a and 72b / Epicord Figure 72b - page 56).
- Install the shore power input connector into the new hole in the sidewall (Figure 73a) using a screw gun with a #2 square drive bit and the four (4) original fasteners (Figure 73b).



Figure 73a

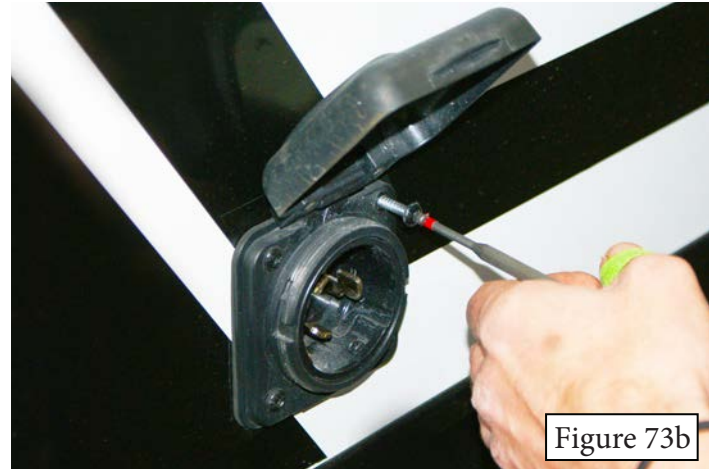
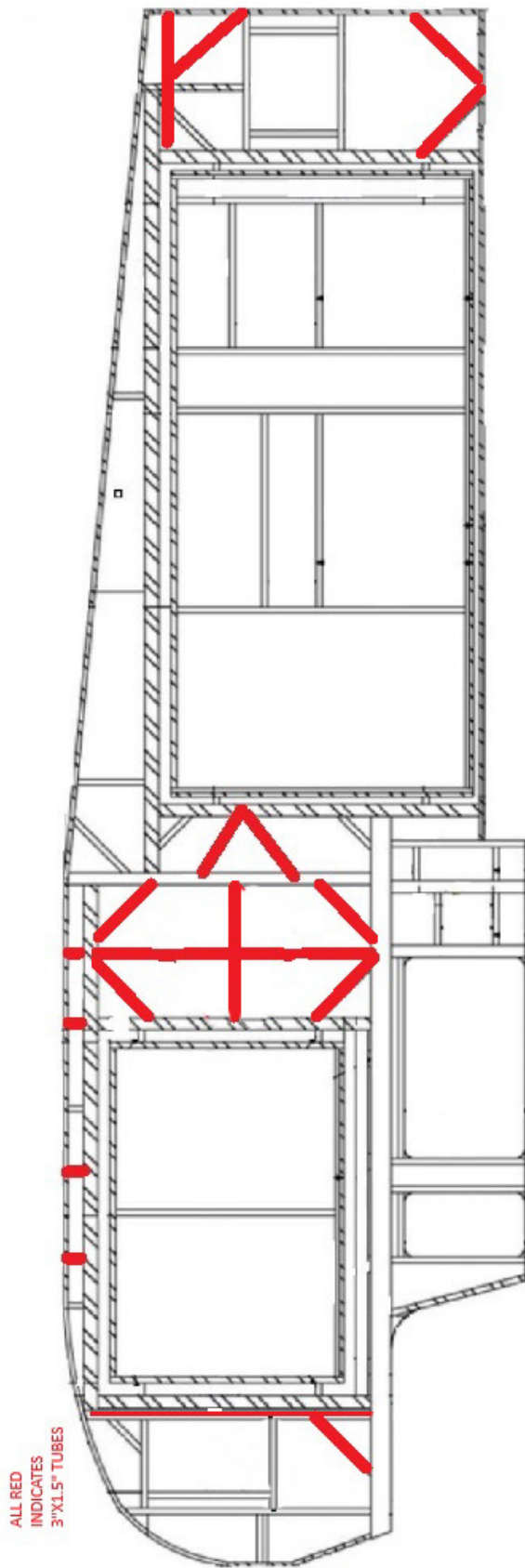

Figure 73b

4. Perform final body and paint work. Repair any defects in fiberglass, screw holes, and sealant prior to painting.
5. Install graphics as necessary.
6. Final inspection, leak test and detailed review of body work, paint and exterior sealants.
7. Installation complete. File claim through Brinkley Dealer Portal or through Brinkley Customer Care Department at [CustomerCare@Brinkleyrv.com](mailto:CustomerCare@Brinkleyrv.com).

**Z2900 WALL  
STRUCTURE**



**Z3100 WALL  
STRUCTURE**

ALL RED  
DENOTES A  
3"x1.25" TUBE

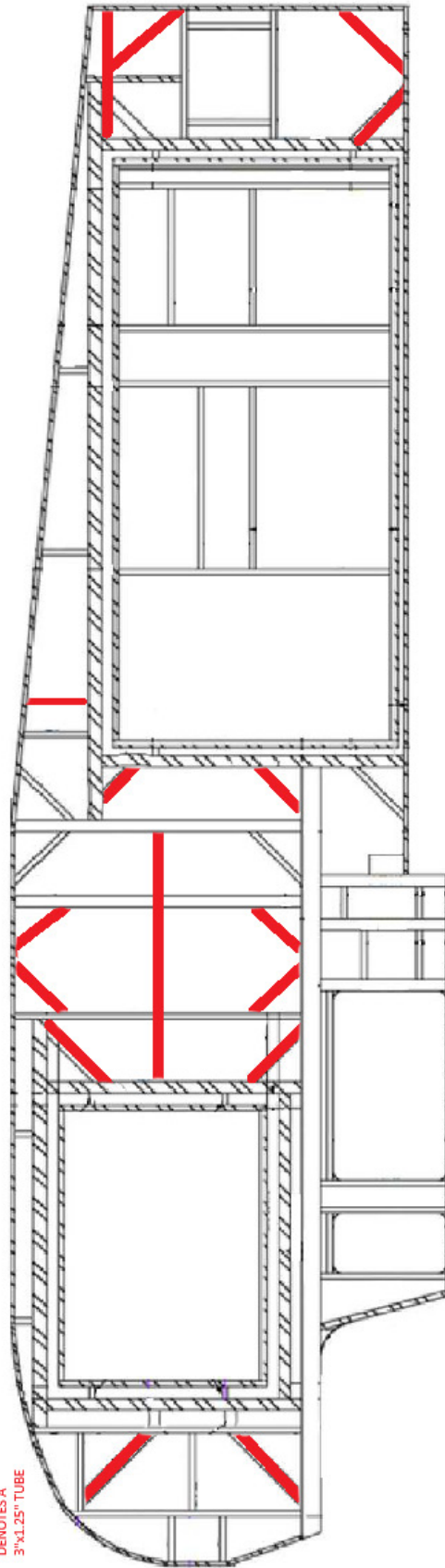

| Z3100 STRUCTURE COLOR KEY |                    |                  |
|---------------------------|--------------------|------------------|
| COLOR                     | EXISTING STRUCTURE | ADD IF NOT THERE |
| WHITE                     | X                  |                  |
| YELLOW                    |                    | X                |
| RED                       |                    | X                |

**Z3110 WALL  
STRUCTURE**

RED DENOTES  
3"x1.5" TUBES

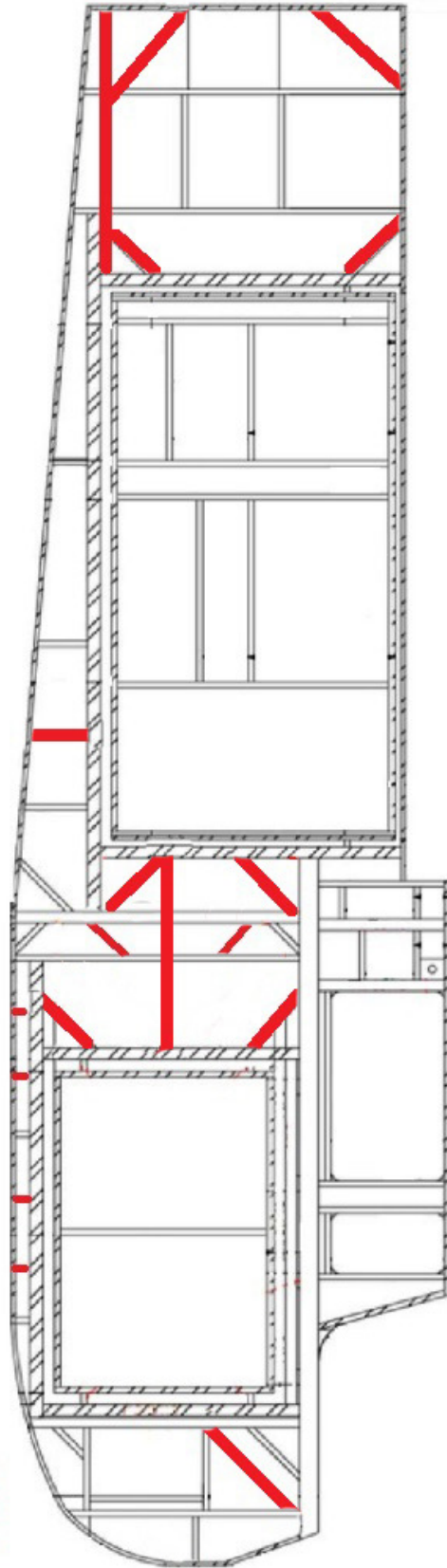

| Z3100 STRUCTURE COLOR KEY |                    |                  |               |
|---------------------------|--------------------|------------------|---------------|
| COLOR                     | EXISTING STRUCTURE | ADD IF NOT THERE | ADD STRUCTURE |
| WHITE                     | X                  |                  |               |
| YELLOW                    |                    | X                |               |
| RED                       |                    |                  | X             |

Z3400 WALL  
STRUCTURE

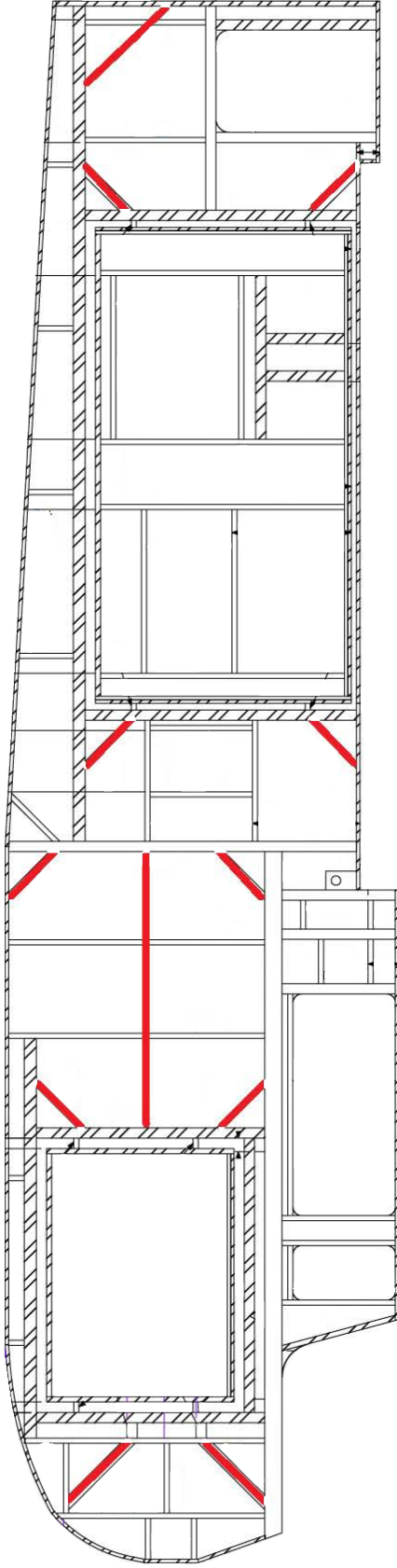

| Z3100 STRUCTURE COLOR KEY |                    |                  |               |
|---------------------------|--------------------|------------------|---------------|
| COLOR                     | EXISTING STRUCTURE | ADD IF NOT THERE | ADD STRUCTURE |
| WHITE                     | X                  |                  |               |
| YELLOW                    |                    | X                |               |
| RED                       |                    |                  | X             |

## ADDITIONAL VENDOR INFORMATION ACCESS

Additional information is available on various systems and components you may encounter while performing the repairs in this document. The QR codes listed below provide links to the various manufacturer's service and/or installation information. **If there is a discrepancy between the instructions provided by Brinkley in this document and the component manufacturers information, default to the component manufacturers instructions.**

If you have additional questions, please contact Brinkley Customer Care at 888-502-3460, or 574-501-4280, Mon-Fri, 8AM to 5 PM EST, or email: "[CustomerCare@BrinkleyRV.com](mailto:CustomerCare@BrinkleyRV.com)".

---

**Lippert Slim-Rack Slide-Out  
Programming, Installation and  
Service Manual**



**Installation and  
Service Instructions**

---

**KORAPUR urethane adhesive  
sealant (Brinkley P/N 112154)  
Adhesive Information**

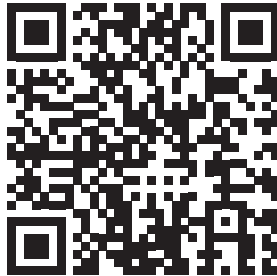

**General  
Information**



**Safety Data Sheet**

---

**EternaBond MicroSealant  
Tape (Brinkley P/N 102489)  
Information**



**Installation  
Instructions**



**Safety Data Sheet**