

**Technical Service Bulletin (TSB)**  
**Power Top Switch Collapsed Into The Overhead Console**

<b>REFERENCE:</b>	<b>TSB:</b> 23-002-26 <b>GROUP:</b> 23 - Body	<b>Date:</b>	February 7, 2026	<b>REVISION:</b>	—
<b>VEHICLES AFFECTED:</b>	<b>2025 (JL) Jeep Wrangler</b> This bulletin applies to vehicles built on or after June 01, 2025 (MDH 0601XX) equipped with Sky One-Touch Power Top (Sales Code STJ).	<b>MARKET APPLICABILITY:</b>		<input checked="" type="checkbox"/> NA <input type="checkbox"/> MEA <input type="checkbox"/> SA <input type="checkbox"/> IAP <input type="checkbox"/> EE <input type="checkbox"/> CH <b>NOTE:</b> This bulletin applies to the North American market.	
<b>CUSTOMER SYMPTOM:</b>	<b>Customers may experience the following:</b> <ul style="list-style-type: none"> <li>The power top switch collapsed and has been pushed inside the overhead console <a href="#">Fig. 1</a>.</li> </ul> <b>NOTE:</b> The switch will still operate the top after being pushed in.				
<b>CAUSE:</b>	Manufacturing issue				

This Technical Service Bulletin (TSB) has also been released as a Rapid Service Update (RSU) 26-029, date of issue February 07, 2026. All applicable RSU VINs have been loaded. To verify this RSU service action is applicable to the vehicle, use VIP or perform a VIN search in DealerCONNECT/Service Library. All repairs are reimbursable within the provisions of warranty.



**Fig. 1**  
Collapsed Switch Power Top Switch

**REPAIR SUMMARY:**

This bulletin involves inspecting the power top switch and possibly replacing the overhead console bezel.

**CLAIMS DATA:**

Labor Operation No:	Labor Description	Skill Category	Labor Time
23-14-02-9C	Console, Overhead - Inspect Power Top Switch Trim Bezel (0 - Introduction)	6 - Electrical and Body Systems	0.2 Hrs.
23-14-02-9D	Console, Overhead - Inspect and Replace Power Top Switch Trim Bezel (0 - Introduction)	6 - Electrical and Body Systems	0.7 Hrs.
Failure Code	ZY	Service Action	

**RELATED LOP:**

Labor Operation No:	Labor Description	Skill Category	Labor Time
08-00-01-51	12-Volt Battery Disconnect / Connect – PHEV (0 - Introduction)	6 - Electrical and Body Systems	0.4 Hrs.

**SPARE PARTS:**

Qty	Part No.	Description	Notes
1 (AR)	7FX93TX7AC	Bezel, Overhead Console	(reuse the power top switch)

**DIAGNOSIS:**

If a customer's VIN is listed in VIP or your RSU VIN list, perform the repair. If any vehicle not on the VIN list exhibits any of the symptom listed above in the customer symptom section, perform the Repair Procedure.

**REPAIR PROCEDURE:**

1. Inspect the switch by cycling the power top switch three times.
2. Did the power top switch collapse or press into, the overhead console [Fig. 1](#)?
  - YES >>> Proceed to [Step 3](#).
  - NO >>> Use Inspect LOP (23-14-02-9C) to close the active RSU.
3. **For PHEV vehicles:** Disconnect the 12 volt battery. Refer to the detailed service procedures available in DealerCONNECT > Service Library under: Service Info>08 - Electrical / 8F - Engine Systems / Battery System / Standard Procedure>12-volt Battery Disconnect - PHEV.
4. Remove the front header panel. Refer to the detailed service procedures available in DealerCONNECT/ Service Library under: 23 - Body / Interior / Panels / Removal.
5. Disconnect all wire harness connectors.
6. Remove the four fasteners [Fig. 2](#) and the overhead console from the front header panel.

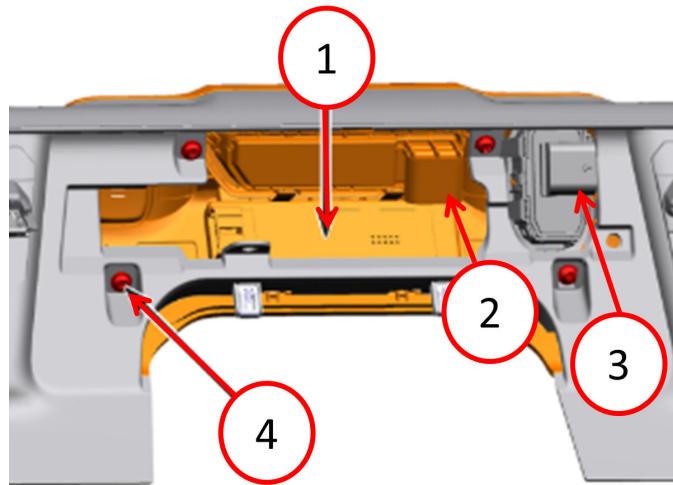

**Fig. 2**  
Overhead Console Assembly

- 1 - Microphone Array
- 2 - Air Bag Control Switch
- 3 - Power Top Switch
- 4 - Fastener

7. Disengage the tabs and remove the microphone array [Fig. 2](#) from the overhead console.
8. Disengage the tabs and remove the air bag control switch [Fig. 2](#) from the overhead console.
9. Disengage the tabs and remove the power top switch [Fig. 2](#) from the overhead console.
10. Install the power top switch [Fig. 2](#) to the overhead console.
11. Install the air bag control switch [Fig. 2](#) to the overhead console.
12. Install the microphone array [Fig. 2](#) to the overhead console.
13. Using the four fasteners [Fig. 2](#), install the **NEW** overhead console to the front header panel.
14. Connect all wire harness connectors.
15. Install the front header panel. Refer to the detailed service procedures available in DealerCONNECT/ Service Library under: 23 - Body / Interior / Panels / Installation.
16. **For PHEV vehicles:** Connect the 12 volt battery. Refer to the detailed service procedures available in DealerCONNECT > Service Library under: Service Info>08 - Electrical / 8F - Engine Systems / Battery System / Standard Procedure>12-volt Battery Connect - PHEV.

**POLICY:**

Reimbursable within the provisions of the warranty.

*This bulletin is supplied as technical information only and is not an authorization for repair. No part of this publication may be reproduced, stored in a retrieval system, or transmitted, in any form or by any means, electronic, mechanical, photocopying, or otherwise, without written permission of FCA US LLC.*