

January 26, 2026

Version 4

## Pop or Clunk From The Rear In Cold Weather Over Bumps

Supersedes version 3 to revise the information at:

Under REQUIRED MATERIALS, information was updated.

### APPLIES TO

Year	Model	Trim	VIN Range
2006-14	Ridgeline	ALL	ALL

### SYMPTOM

A pop or clunk is heard from the rear suspension in cold weather going over bumps.

### POSSIBLE CAUSES

The rear bump stops have loosened and are moving in the top mounting cap for the rear dampers.

### CORRECTIVE ACTION

Apply a small amount of adhesive to the upper surface of the bump stop.

### PART INFORMATION

Part Name	Tool Number	Quantity
Nut, Flange (10MM)	90002-S10-000	2
Bolt, Flange (18x76)	90119-SJC-A10	2
Bolt, Flange (10x42)	90172-SJC-A01	6
Bolt, Rear Knuckle (16x90)	90174-SJC-A00	2
Nut, Self-Lock (12MM) (NYLON)	90362-SJP-A00	2
Nut, Self-Lock (10MM) (NYLON)	90364-S5D-A01	2

### SPECIAL TOOLS

Tool Name	Part Number	Quantity
Application Gun	08713-0010	1
Mixer Tips	08713-0011	1 (package of 12)

### REQUIRED MATERIALS

Materials	Part Number	Quantity
Fusor® 147 Plastic Bonding Adhesive (Medium)	Fusor 147 (commercially available)	1 (repairs 5 vehicles/10 damper assemblies per tube)

**CUSTOMER INFORMATION:** The information in this bulletin is intended for use only by skilled technicians who have the proper tools, equipment, and training to correctly and safely maintain your vehicle. These procedures should not be attempted by "do-it-yourselfers," and you should not assume this bulletin applies to your vehicle, or that your vehicle has the condition described. To determine whether this information applies, contact an authorized Honda automobile dealer.

## WARRANTY CLAIM INFORMATION

The normal warranty applies.

Operation Number	Description	Flat Rate Time	Defect Code	Symptom Code	Template ID	Failed Part Number
4171C3	Apply Adhesive to Bump Stops. Includes disassemble both rear damper assemblies, apply adhesive to the bump stops and reassemble (includes check wheel alignment and adjust if necessary.)	2.3 hrs	00504	04201	14-077A	56210-SJC-A01

## REPAIR PROCEDURE

1. Raise and support the vehicle.
2. Remove the rear wheels.
3. Position a floor jack at the connecting point of lower arm B and the knuckle. Raise the floor jack until the suspension begins to compress.

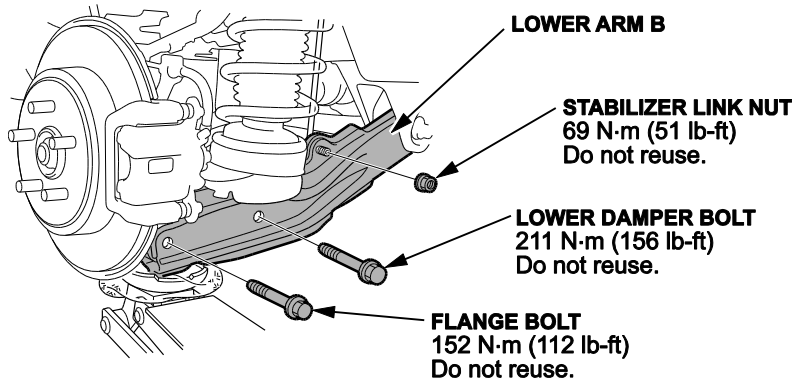

4. Remove the stabilizer link nut, then remove the flange bolt that attaches lower arm B to the rear knuckle, then lower the floor jack gradually.
5. Remove the flange bolt for the rear damper.
6. Mark the cam positions of the adjusting bolt and the adjusting cam plate, then remove the self-locking nut, the adjusting cam plate, and the adjusting bolt.

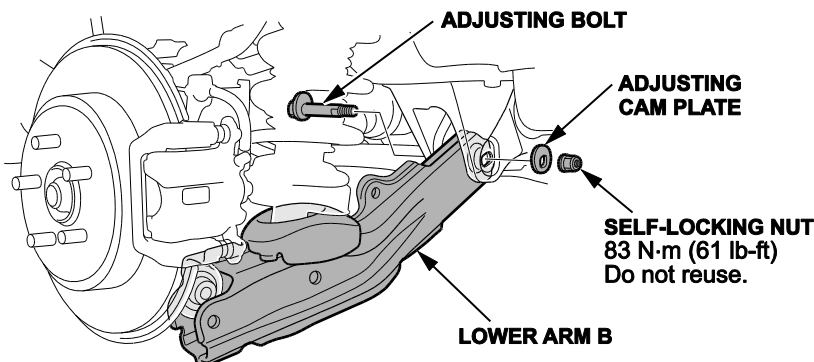

7. Remove the lower arm B
8. Remove the three flange bolts from the top of the damper, and then remove the damper assembly.

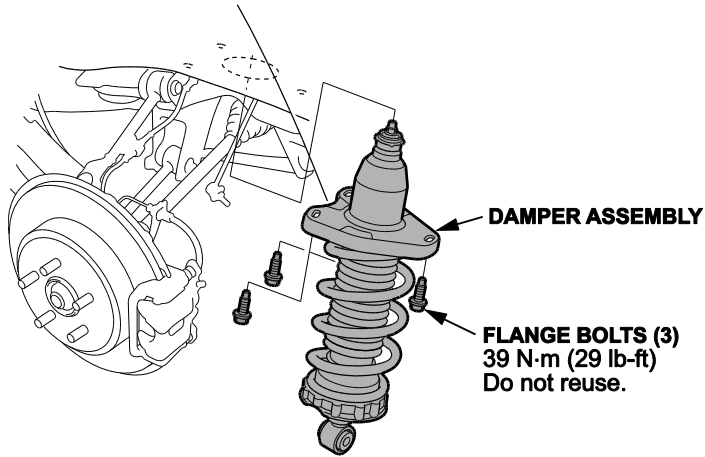

9. Compress the damper spring, then remove the self-locking nut while holding the damper shaft with a hex wrench. Do not compress the spring more than necessary to remove the self-locking nut.

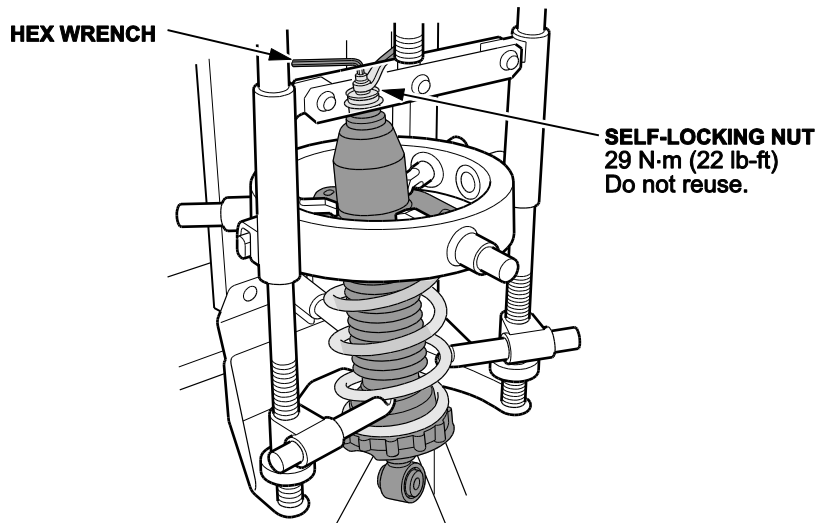

10. Release the pressure from the spring compressor, and then disassemble the damper.
11. Thoroughly clean the upper surface of the bump stop.

12. Apply a small amount of adhesive to the upper surface of the bump stop.

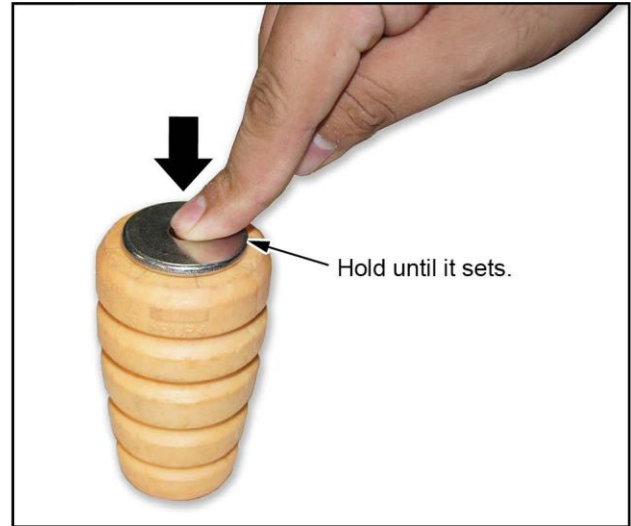
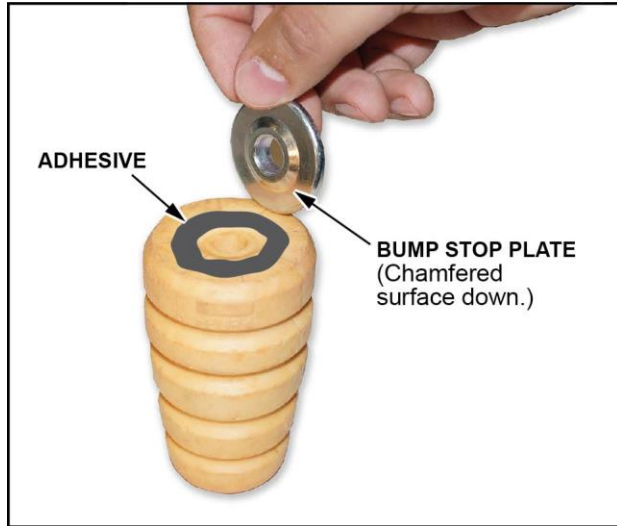

13. Hold the bump stop plate against the bump stop until the adhesive cures (approximately 2 minutes).

14. Reassemble the damper spring using a new self-locking nut. Torque the nut to **29 N·m (22 lb-ft)**.

15. Reinstall the damper assembly into the vehicle then loosely install new flange bolts.

16. Install lower arm B in the reverse order of removal and note these items

- Install all of the components and lightly tighten the bolts and nuts, then raise the suspension to load it with the vehicle's weight before fully tightening to the specified torque.
- Align the cam positions of the adjusting bolt and adjusting cam with the marked positions then tighten the nut to **83 N·m (61 lb-ft)**.
- Torque the flange bolt that attaches lower arm B to the rear knuckle to **152 N·m (112 lb-ft)**.
- Torque the lower damper bolt to **211 N·m (156 lb-ft)**.
- Torque the stabilizer link nut to **69 N·m (51 lb-ft)**.
- Torque the three upper damper bolts to **39 N·m (29 lb-ft)**.

17. Repeat steps 3-16 for the other side.

18. Install the rear wheels.

19. Lower the vehicle.

20. Check the wheel alignment and adjust if necessary.