



GROUP	MODEL
Voluntary Service Campaign	2024-2025MY EV9(MV) and 2025-2026MY EV9(MVa)
NUMBER	DATE
SC360	February 2026

## VOLUNTARY SERVICE CAMPAIGN

SUBJECT:

### EF31 CONNECTOR BRACKET REPLACEMENT (SC360)

This bulletin provides information on repositioning the EF31 electrical connector by replacing the bracket with an improved one for certain EV9 (MV, MVa) vehicles within the production ranges listed in the table below. The EF31 electrical connector, located near the top of the driver's footrest, may become disconnected due to interference from the driver's foot. If this electrical connector becomes disconnected, the 12V battery may discharge, which can cause the service warning light and/or "check electric vehicle system" message to illuminate. If the vehicle continues to be driven in this condition, the Power Limited (Turtle) warning light may illuminate, and the vehicle may enter Limp Home Mode with speed temporarily limited. Follow the procedure outlined in this bulletin to reposition the EF31 electrical connector by replacing the bracket with an improved bracket to prevent accidental disconnection by the driver's foot. Before performing the procedure, confirm that the vehicle is included in the affected VIN list.

Model	Production Date Range
EV9 (MV)	September 25, 2023 to October 15, 2024
EV9 (MVa)	May 17, 2024 to April 29, 2025

#### NOTICE

**There is no charge to the vehicle owner for this repair.** Repair status for a VIN is provided on KDealer+ (Service → Warranty Coverage → Warranty Coverage Inquiry → Campaign Information). Not completed Recall / Service Action reports are available on KDealer+ (Consumer Affairs → Not Completed Recall → Recall VIN → Select Report), which includes a list of affected vehicles.

A printed copy is for reference only; publication information can be updated at any time. Always refer to KGIS for the latest information. After logging in kdealer.com, the newest technical publications are listed in 'Service Releases' and has the latest service information that has been released.

**Repair Procedure:**

1. Disconnect the auxiliary 12 V battery negative (-) terminal (A) by referring to 'Body (Interior / Exterior / Electrical) → High Voltage Shut-off Procedures' (Steps 1 - 3) in the applicable Shop Manual in KGIS.



2. Press lock tab (B) and then disconnect connector EF31 (C).

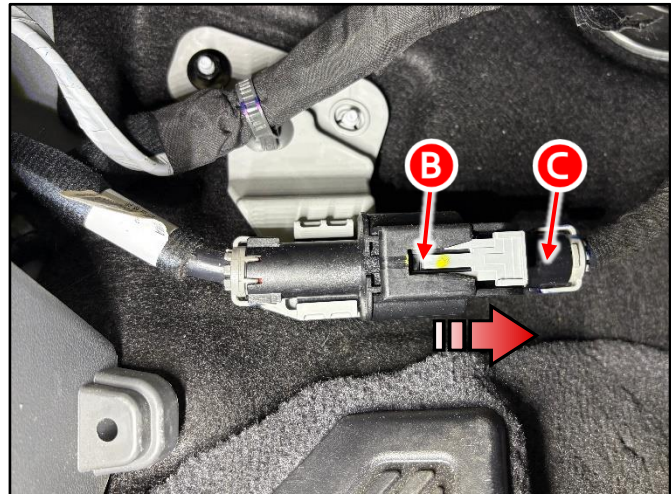

3. Remove wiring harness bracket nut (D).

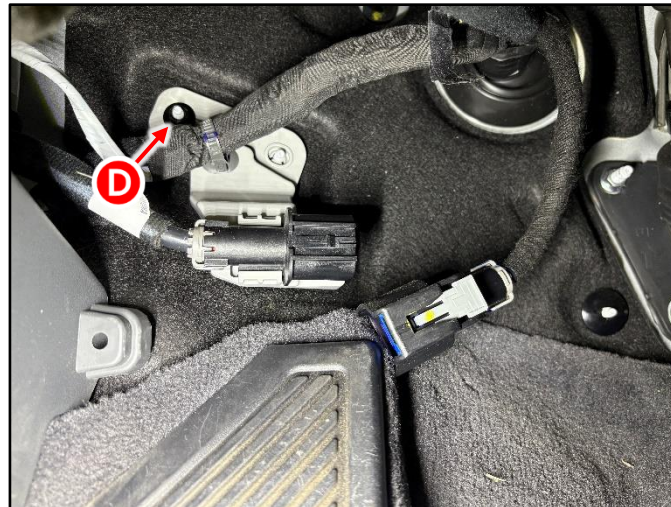

SUBJECT:

## EF31 CONNECTOR BRACKET REPLACEMENT (SC360)

4. Release wiring harness clip (E) from wiring harness bracket (F) using needle nose pliers to gently release the clip from the backside of the harness bracket to prevent damage.

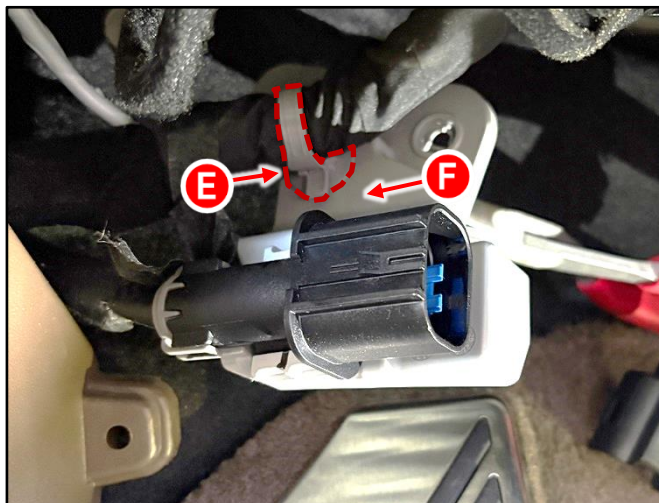

5. Using a flat-blade screwdriver or panel removal tool, gently pry connector EF31 (C) free from the old wiring harness bracket (F).

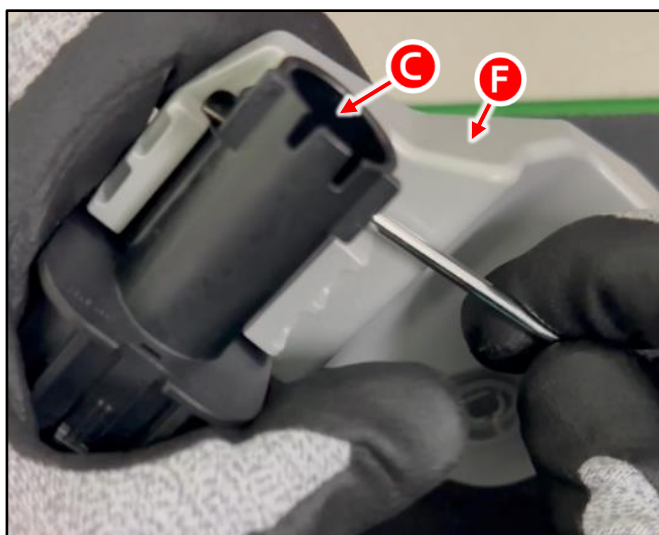

6. Install new connector clip (G) onto connector EF31 (C) until it clicks securely into place.

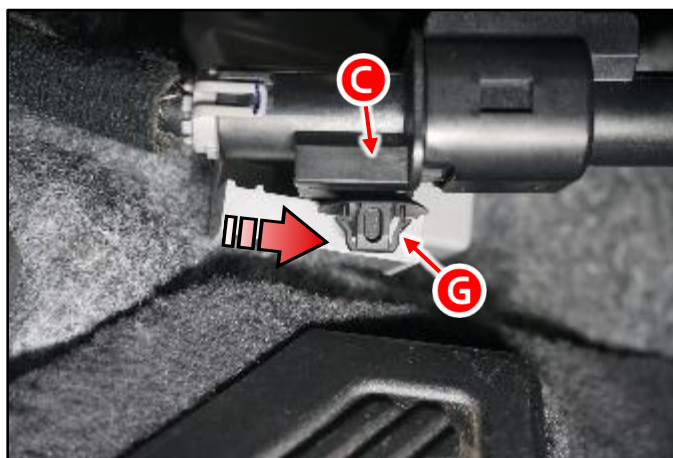

SUBJECT:

## EF31 CONNECTOR BRACKET REPLACEMENT (SC360)

- 7a. Install the new wiring harness bracket (F).
- 7b. Reinstall the wiring harness bracket nut (D).
- 7c. Secure the connector clip (G) to wiring harness bracket (F).
- 7d. Reinstall wiring harness clip (E) into the wiring harness bracket (F).

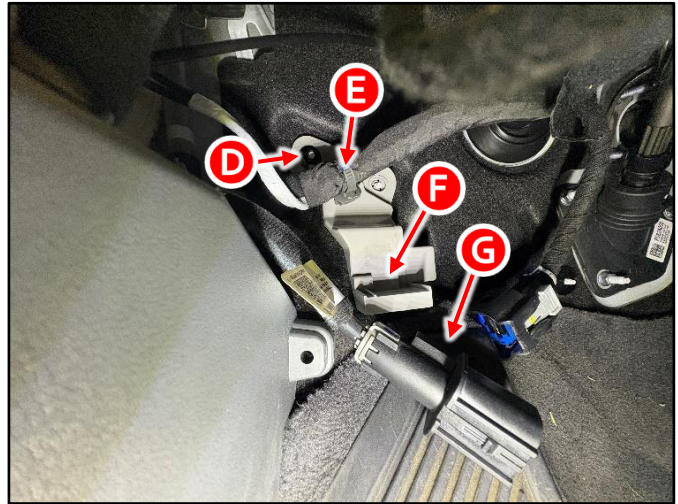

- 8. Reconnect connector EF31 (C).

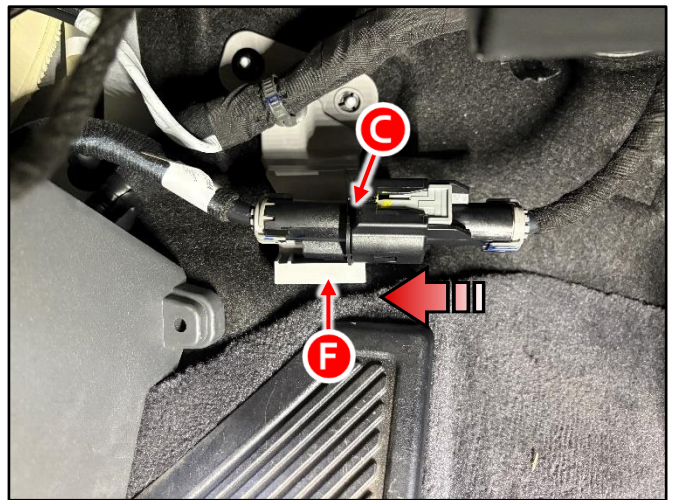

- 9. Reconnect the auxiliary 12 V battery negative (-) terminal (A).

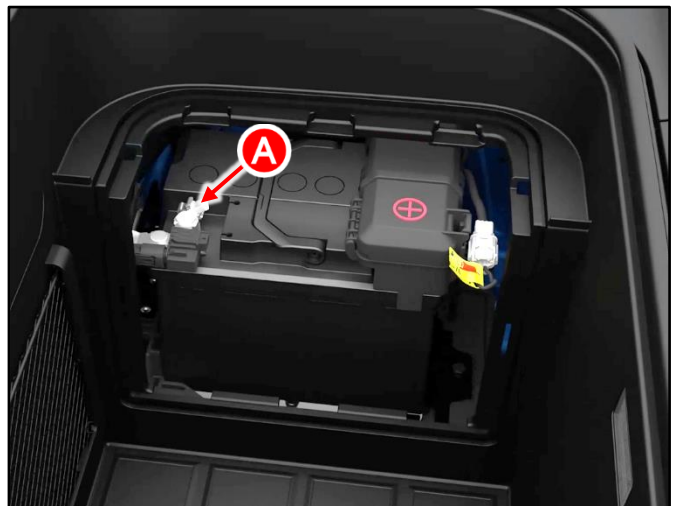



- 10. Confirm normal operation.

SUBJECT:

**EF31 CONNECTOR BRACKET REPLACEMENT (SC360)****AFFECTED VEHICLE RANGE:**

Model	Production Date Range
EV9 (MV)	September 25, 2023 to October 15, 2024
EV9 (MVa)	May 17, 2024 to April 29, 2025

**REQUIRED PART:**

Part Name	Part Number	Figure	Qty.	Comments
Wiring Harness Bracket	91961 DO560QQK		1	N/A
Connector Clip	919FA DO110QQK			

**WARRANTY INFORMATION:****N Code: N99 C Code: C99**

Model	Claim Type	Causal P/N	Qty.	Repair Description	Labor Op Code	Op Time	Replacement P/N	Qty.
MV	R	91961 DO560	0	(SC360) EF31 Connector Bracket Replacement	250230R0	0.3 M/H	91961 DO560QQK <u>and</u> 919FA DO110QQK	1
MVa					250A64R0		91961 DO560QQK <u>and</u> 919FA DO110QQK	1

**Note:** Refer to [Warranty Bulletin 2026-08](#) for claim submission procedures. **When substitute transportation is provided, manually enter sublet code 'X2' for rental expense reimbursement or one roundtrip rideshare expense.** Make sure to submit any substitute transportation claim at the time of the warranty expense.

**NOTICE**

VIN inquiry data for this repair is provided for tracking purposes only. Kia retailers should reference **SC360** when accessing the KDealer+ system.

