

Technical Service Bulletin

Topic	Bentayga V8 Kovomo - DTC P310B00 with Symptom Code 2638 - Check Engine Lamp - Fuel Pressure Regulation
Market area	Bentley: worldwide (2WBE)
Brand	Bentley
Transaction No.	2058484/14
Level	EH
Status	Released for publishing
Release date	Dec 10, 2025

Diagnostic trouble codes

Diagnostic address	Diagnostic trouble code	Fault symptom	Storage state
0001 - Engine electronics	P310B00: Low fuel pressure regulation Fuel pressure outside specification		static
0001 - Engine electronics	P310B00: Low fuel pressure regulation Fuel pressure outside specification		Intermittent

New customer code

Object of complaint	Complaint type	Position
engine -> engine operation -> engine output characteristic	functionality -> misfire	
engine -> engine operation	functionality	

New workshop code

Object of complaint	Complaint type	Position
engine -> operation, engine control -> engine control module	control modules, services -> measured value too high	
engine -> operation, engine control -> engine control module	functionality -> misfire	
engine -> operation, engine control -> engine control module	control modules, services -> with fault stored in the DTC memory	
engine -> fuel supply -> low pressure fuel pump, tank side	functionality -> irregular	
engine -> operation, engine control -> engine control module	electrical -> ground connection damaged	

engine -> operation, engine control -> engine control module

control modules, services -> error message

Vehicle data

Bentayga Series - V8 Kovomo

Sales types

Type	MY	Brand	Designation	Engine code	Gearbox code	Final drive code
4V14D9	2018	E		*	*	*
4V14D9	2019	E		*	*	*
4V14D9	2020	E		*	*	*
4V14D9	2021	E		*	*	*
4V14D9	2022	E		*	*	*
4V14D9	2023	E		*	*	*
4V14D9	2024	E		*	*	*
4V14D9	2025	E		*	*	*
4V14D9	2026	E		*	*	*
4V15D9	2024	E		*	*	*
4V15D9	2025	E		*	*	*
ZV14D9	2023	E		*	*	*
ZV14D9	2024	E		*	*	*
ZV14D9	2025	E		*	*	*

Documents

Document name

[master.xml](#)

Condition

Engine warning lamp is illuminated within the Driver Instrument Panel (DIP) in conjunction with the DTC as detailed below:

- ***“P310B00 with symptom code 2638 - Low Fuel Pressure Regulation”***

There may also be multiple DTC's and symptoms present due to fuel pressure regulation or fuel supply issues in conjunction with the afore mentioned symptom/DTC

Technical Background



NOTE: Where possible the retailer must attempt to request as much information as possible regarding when the issue occurred - For example

- Driving at low speed in traffic
- Warning lights within the DIP
- Driveability at the time the issue occurred - During idle or driving?
- If during idle, how long had the car been idling?
- Details when the vehicle was last refuelled and the grade of fuel used
- When the issue occurred, How was the car unlocked and started? Keyless entry or entry by using the remote key fob?



IMPORTANT: All received information must be added to a new or existing Technical DISS query

In the event the symptoms are as described within the Customer statement/workshop findings section of this TPI the operative should refer to the instructions within the Measure section noting the following before proceeding

NOTICE

There are (x2) different fuel pressure actual values depending on the Model Year

- 18 to 22 Model Year
- 23 Model Year

The operative must ensure the correct procedure is followed

Production Solution

All vehicles post SJAHL14V0PC021480 are to specification, however in the event the issue is evident post the suggested VIN the operative should raise a Technical DISS query and await feedback before conducting any further work

Service



WARNING

Before continuing with the onward instructions the operative must refer to and understand the following information within Rep.Gr 20:

– Basic safety instructions for working with the fuel system

- Fuel system - Safety precautions
- Fuel system - Rules for cleanliness
- Always drain fuel tank before performing any work on the fuel system - Drain fuel tank - Refer to Rep. Gr 20



CAUTION

Ensure all safety instructions are strictly followed including the deactivation of the 48 volt system (when applicable) and 12 volt system as per all instructions within Rep.Gr 27

18 to 22 Model Year vehicles only

1) Referring to the example shown in Figure 1 - Check the actual pressure value

- In the event the fuel pressure actual value is above 450kPa the Fuel Delivery Module within the fuel tank (Figure 2) should be replaced



The fuel tank flange seal and securing ring should also be replaced

- Refer to Repair Group 20 Fuel supply, gas operation / 4.0L V8 TSI / Fuel pump, fuel level sensors, and jet pump (RH) - To remove and fit

23 Model Year vehicles only

1) Referring to the example shown in Figure 1 - Check the actual pressure value

- In the event the fuel pressure actual value is above 475kPa (2023MY) the Fuel Delivery Module within the fuel tank (Figure 2) should be replaced



The fuel tank flange seal and securing ring should also be replaced

- Refer to Repair Group 20 Fuel supply, gas operation / 4.0L V8 TSI / Fuel pump, fuel level sensors, and jet pump (RH) - To remove and fit.

All Model Years continued

- Extended ambient conditions:

Engine rpm	639.5	1/min
Normed load value	13.725490449999999	%
Vehicle speed	0	km/h
Coolant temperature	82	°C
Intake air temperature	42	°C
Ambient air pressure	1000	mbar
Voltage terminal 30	12.4	V
Dynamic environmental data	20 96 28 11 CE 11 94 11 C8 12 80 11 C9	
	F8 41 11 A4 26 66 12 8AAA 15 9F 66 60	
	15 A0 66 64	
Unlearning counter according OBD	40	
Low fuel pressure, specified value	450.0	kPa
Fuel low pressure, actual value	501.3	kPa
Fuel pump adaptation	-198.3	kPa
Fuel pump, specified value	14.99939	%
Fuel temperature	79.5	°C
Fuel high-pressure, actual value	13.104	MPa
Fuel pressure rail 2	13.106	MPa



Figure 1

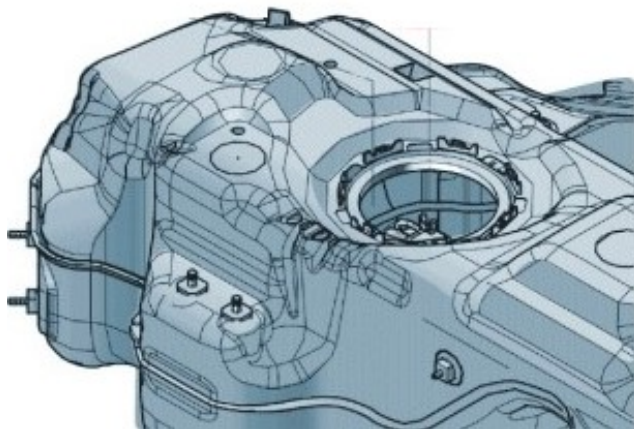
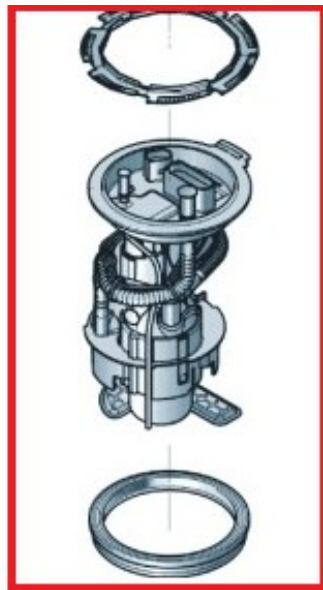

Figure 2

! NOTICE

IMPORTANT: Once the fuel delivery module has been replaced, the operative should attach a clear photograph of the manufacture information label as shown in Figure 3

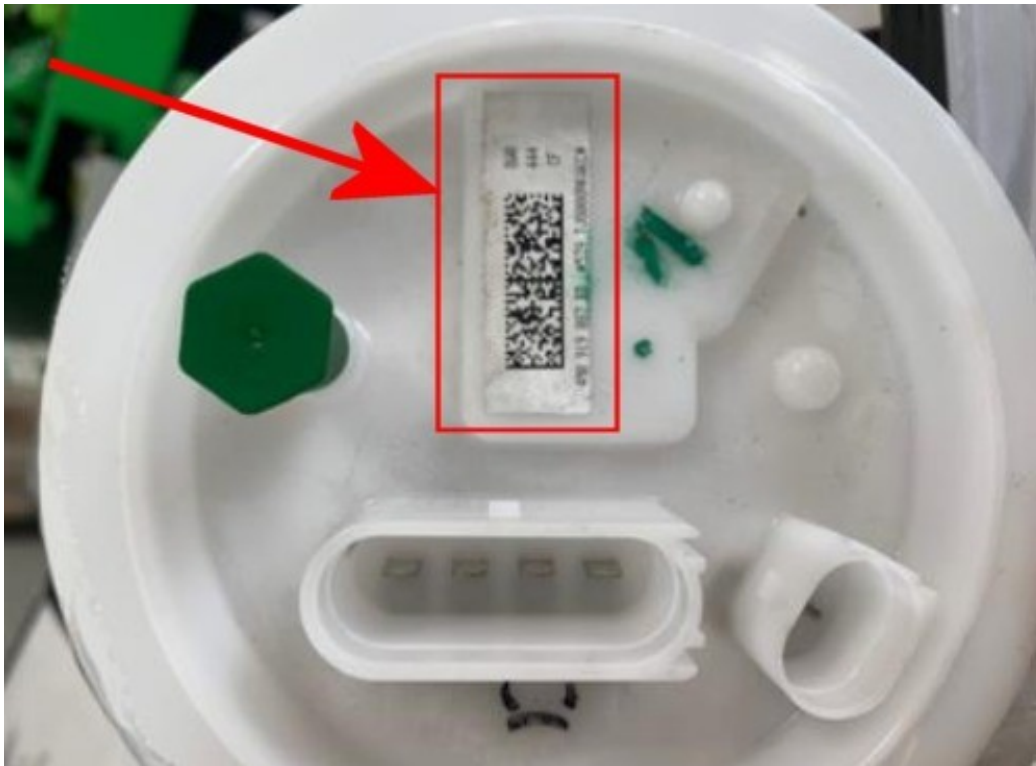

Figure 3

Warranty

Warranty type - 110 or 910

Damage Service Number 20 66

Damage Code 01 00

Diagnosis time

Labour Operation Code 01 50 00 00

Time As per ODIS log (must not exceed 20 TU)

Time to replace the fuel delivery module

Labour Operation Code 20 66 19 50

Time 50 TU

Time to remove and refit the rear seats (4 seat)

Labour Operation Code 68 16 19 01

Time 190 TU

Time to remove and refit the rear seats (5 seat)

Labour Operation Code 72 48 20 05

Time 100 TU

Time to remove and refit the seat sill panel

Labour Operation Code 68 05 19 00

Time 20 TU

Time to remove and refit the boot side trim panel

Labour Operation Code 70 03 19 00

Time 40 TU

Required Parts and Tools

For the latest part information always refer to the Electronic Parts Catalogue (ETKA)