



**HYUNDAI**  
**Technical Service Bulletin**

GROUP <b>BODY</b>	NUMBER <b>25-BD-011H-1</b>
DATE <b>DECEMBER 2025</b>	MODEL(S) <b>SANTA CRUZ (NXT)</b>

**SUBJECT:** TONNEAU COVER INSPECTION & REPAIR GUIDE

This TSB supersedes 24-BD-003H & 25-BD-011H to combine service procedures for tonneau cover related repairs.

**Description:** Some Santa Cruz (NXT) vehicles may have a tonneau cover that does not latch or unlatch, retract properly, and/or have a v-gap is present when closed. This may be due to a broken or missing clip on the underside of the tonneau cover. This bulletin provides instructions to inspect and, if necessary, repair the tonneau cover function using the Tonneau Cover Repair Kit or replacing the tonneau handle & latch assembly.









**Applicable Vehicles:**

Model Year	Model	Equipped with
ALL	Santa Cruz (NXT)	Tonneau Cover

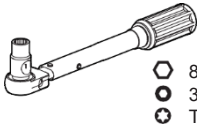
**Parts Information:**

Model	Part Name	Part Number	Figure	Remarks
Santa Cruz (NXT)	Tonneau Handle & Latch Assembly	828C7-K5000QQH		Qty: 1  (order only if latch replacement is necessary)
	Tonneau Cover Repair Kit	828A0-K5000ASFFF		Qty: 1 kit per vehicle  (order only if repair kit is necessary)
<b>Tonneau Cover Repair Kit contents listed below:</b>				
Rubber Strap				Qty: 3
Axle Clip				Qty: 3
Right Lamella Clip				Qty: 20 Marked with "R"
Left Lamella Clip				Qty: 20 Marked with "L"
End Cap Screw				Qty: 6
Lid Screw				Qty: 2
Tension Lock				Qty: 1

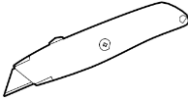
**Required Equipment/Supplies:**

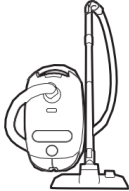
Name	Figure	Remarks
T10 Socket Wrench	 <ul style="list-style-type: none"> <li> 8 mm</li> <li> 3 mm</li> <li> T10</li> </ul>	<ul style="list-style-type: none"> <li>• 8 mm Socket</li> <li>• 3 mm Hex Bit</li> <li>• T10 Torx Bit</li> </ul>
Box Knife		Standard shop supply
Silicone Oil		
Shop Vacuum		

**Warranty Information:**

Model	Op. Code	Operation	Op. Time	Causal Part	Nature Code	Cause Code
Santa Cruz (NXT)	828C7FF0	Tonneau Handle & Latch Replacement	0.3 M/H	828C7-K5000	I11	ZZ3
	828A0FF0	Repair of Tonneau Cover (Repair Kit)	0.6 M/H	828A0-K5000	I21	ZZ1

**NOTE 1:** Normal warranty applies.

**NOTE 2:** This TSB includes repair justification photos. Op times include VIN, Mileage, and repair justification photos as outlined in the Digital Documentation Policy.

**NOTE 3:** The incident parts are subject to callback through the normal Warranty Technical Center (WTC) parts return process. **Claim is subject to debit if the part is not returned.**

**NOTE 4:** If any part(s) not subject to this TSB are found in need of replacement while performing the repair procedure, and the affected part(s) are still under warranty, the dealer may submit a separate claim using the same repair order. If the part(s) not subject to this TSB are out of warranty coverage, the dealer has the option to submit a PA Request for goodwill consideration on a case-by-case basis.

**NOTE 5:** Submit claim on Claim Entry Screen as "Warranty" type.

**Service Procedure:**

**DIGITAL DOCUMENTATION**



This TSB includes repair justification photos. Refer to the latest Warranty Digital Documentation Policy for requirements.

**NOTICE**

Applying the recommended torque to all fasteners is essential to reduce potential issues from occurring after the service procedure.





**NOTICE**

If tonneau cover repair is needed, place the tonneau cover on a clean table during disassembly.

**Table of Contents**

- **Latch & Tonneau Cover Conditions.....5**
- **Tonneau Cover Latch Replacement.....6**
- **Tonneau Cover Repair .....9**
- **Proper Tonneau Cover Operation .....17**

**Latch & Tonneau Cover Conditions**

Condition	QR Code/Link/Figure		Remedy
Handle does <b>NOT</b> open the tonneau cover	<a href="#">Link</a>		<a href="#">Tonneau Cover Latch Replacement</a>
Handle does <b>NOT</b> latch when the cover is closed	<a href="#">Link</a>		
Tonneau cover does <b>NOT</b> retract	<a href="#">Link</a>		<a href="#">Tonneau Cover Repair</a>
Tonneau cover binds and hard to close	<a href="#">Link</a>		
V-Gap between the cover and tailgate when closed and latched			

**Tonneau Cover Latch Replacement**

1. Remove 2 screws (A) then remove 2 end caps from the rear of the vehicle.

Lift the rubber cover (B) to access the 3<sup>rd</sup> end cap then remove the 3<sup>rd</sup> screw (C) and end cap.

***i* Information**

Do **NOT** remove rubber cover (B) from the tonneau cover assembly.

Repeat this step for the other side of the tonneau cover.

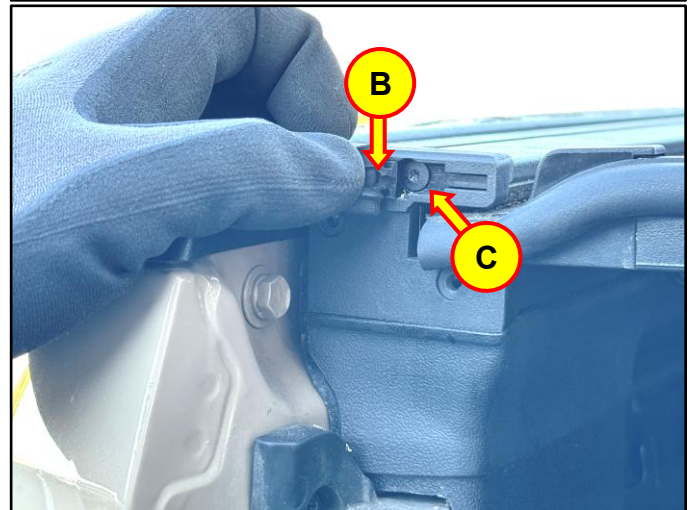
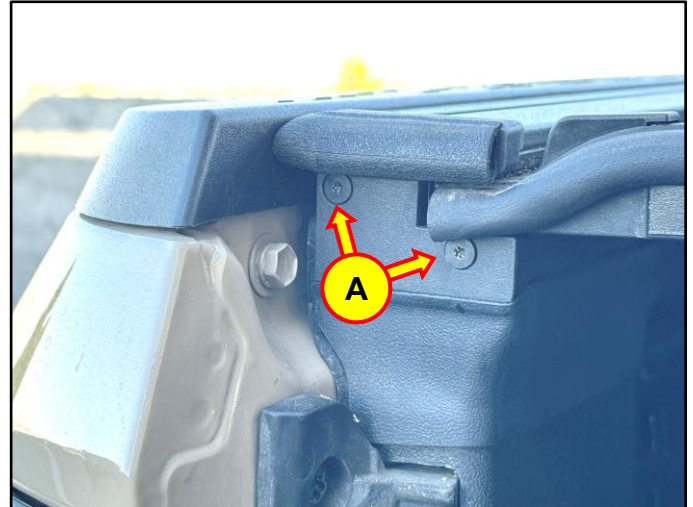

2. Pull out the tonneau cover until the latch assembly (D) passes the rear combination lamp.

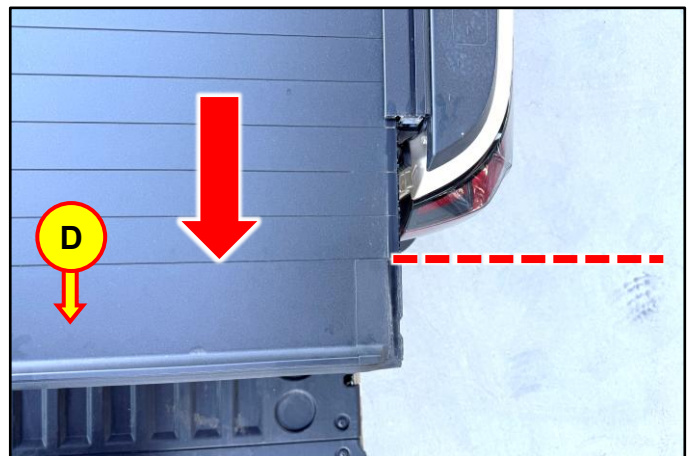

3. Clamp one side of the tonneau cover to prevent it from retracting.

**NOTICE**

Use a rubber or plastic clamp. Do **NOT** use a metal clamp on the tonneau cover to prevent damage.



4. Visually inspect the plastic guide rails (E) under the tonneau cover for displacement.

Reinsert the plastic guide rail(s) into the track(s) if needed.

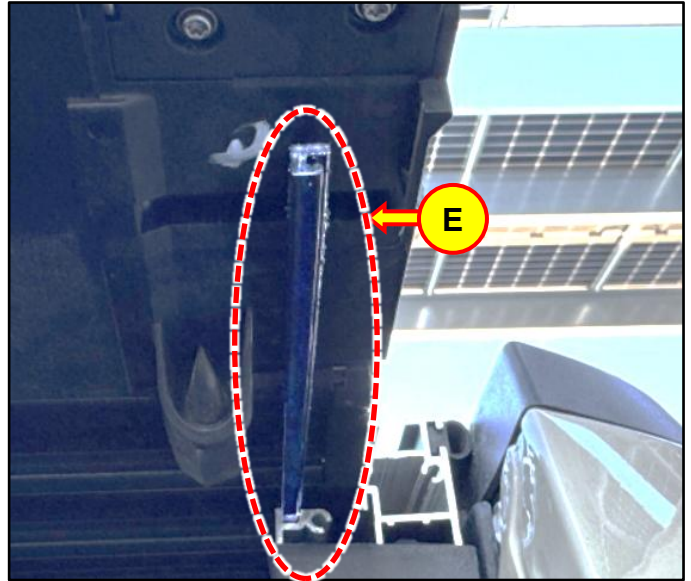

5. Tilt the latch assembly downward then slide it out of the tonneau cover.



6.

**DIGITAL DOCUMENTATION**



Using the STUI camera function, take a photo of the original latch assembly next to the replacement latch assembly.

Upload the photo to STUI.

**NOTE:** If the STUI camera function is **NOT** used, write the last 6 digits of the VIN and date of repair on a piece of paper to include in the photo.



7. Slide the new latch assembly into the tonneau cover.

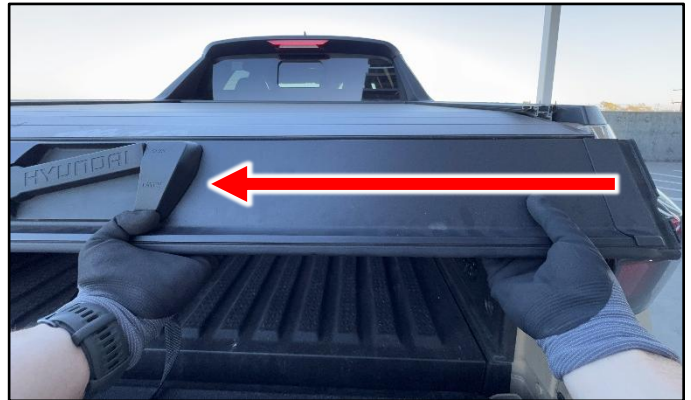

8. Reinstall all parts in the reverse order of removal.

9. Confirm the end caps seals are properly reassembled.

**i Information**

The lower seal **MUST** overlap the end cap, not be underneath.

The upper seal **MUST** be completely flush with the end caps.



10. Confirm the latch properly operates.

**Tonneau Cover Repair**

1. Remove the two **3 mm bolts** (A) then open the tonneau cover lid (B).

**i Information**

Refer to the QR code or link below for a summarized demonstration of the tonneau cover repair procedure:

[Santa Cruz Tonneau Cover Repair Demonstration](#)

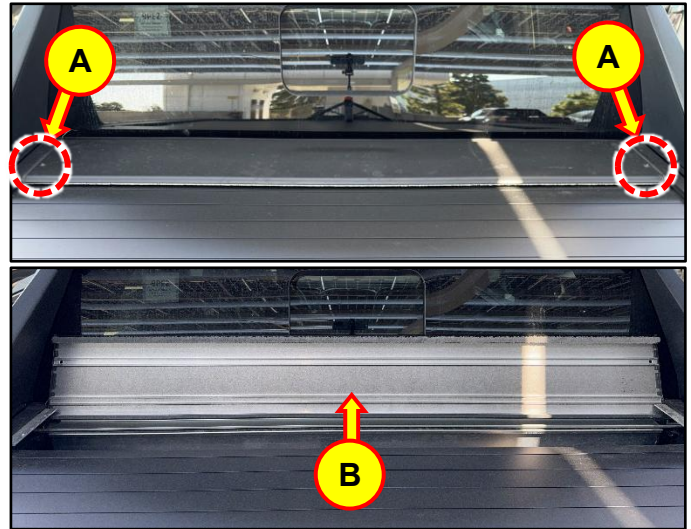

2. Remove **2 screws** (C) then remove **2 end caps** from the rear of the vehicle.

Lift the rubber cover (D) to access the **3<sup>rd</sup>** end cap then remove the **3<sup>rd</sup>** screw (E) and end cap.

**i Information**

Do **NOT** remove rubber cover (B) from the tonneau cover assembly.

Repeat this step for the other side of the tonneau cover.

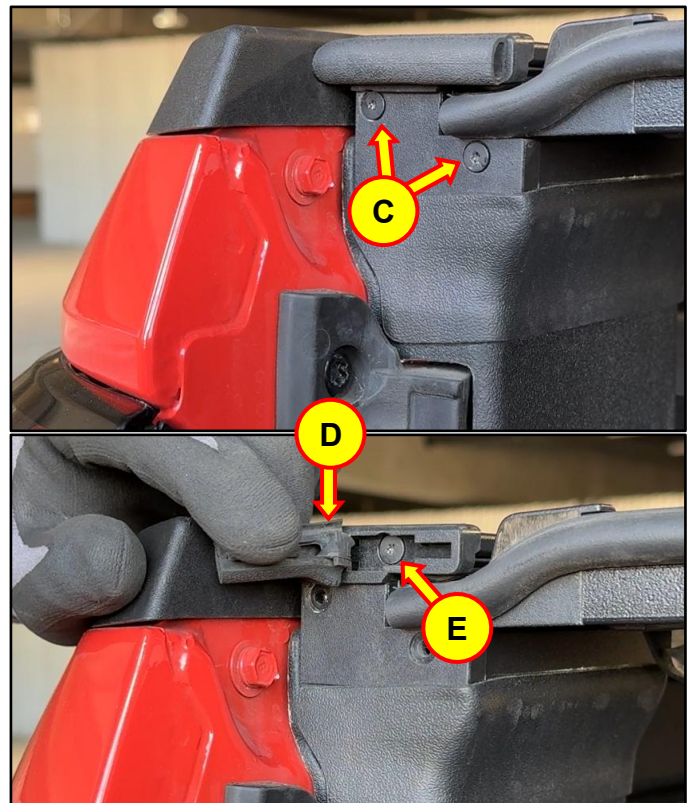

3. Pull out the tonneau cover until the 1<sup>st</sup> two lamellas are hanging off from tracks.



4. Rotate the axle (F) toward the rear of the vehicle then engage the metal tension lock (G) between the axle and the canister to lock the axle in place.

**i Information**

Ensure the side of the axle where the rubber straps are installed is facing up and accessible.

**i Information**

Locking the axle in place will maintain spring tension for the rest of the disassembly procedure.



5. While the spring is under tension, cut the rubber straps (H) flush with the axle.

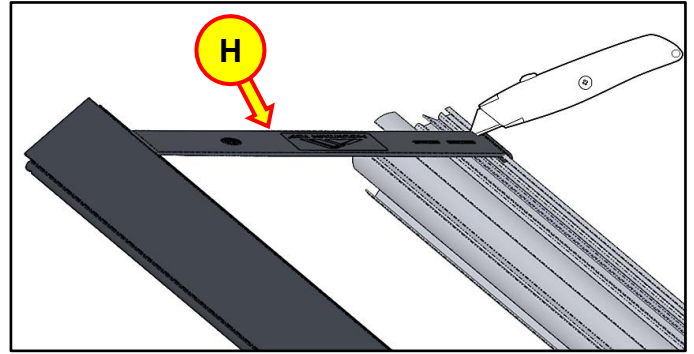

6. Remove the tonneau cover (I) then place it on a clean flat surface, such as a table.

***i* Information**

Ensure the sides of the tonneau cover should hang over the edge of the table to provide access to the lamella clips for steps 9 & 14.

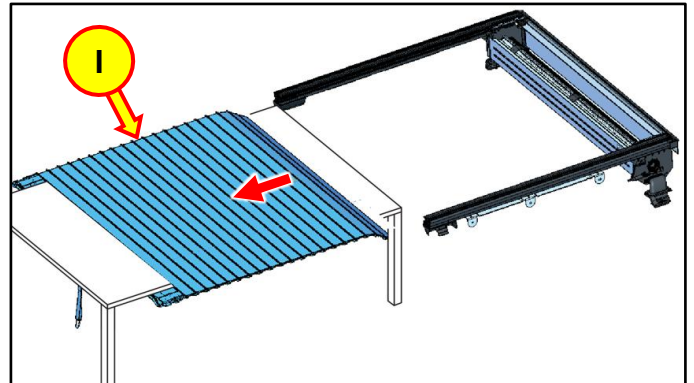

7. Remove any debris from the canister with a shop vacuum.

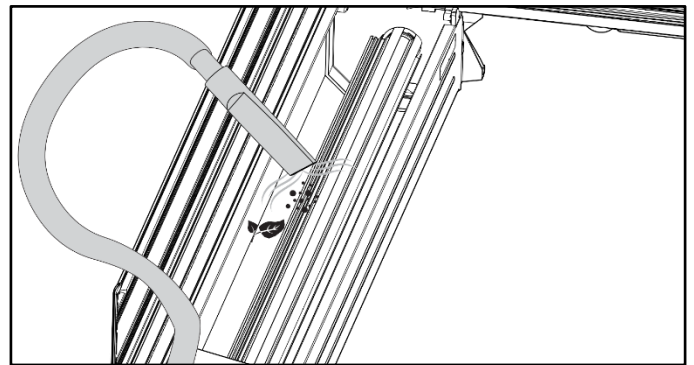

8. Lubricate the side profile flocking strip (J) with silicone oil.

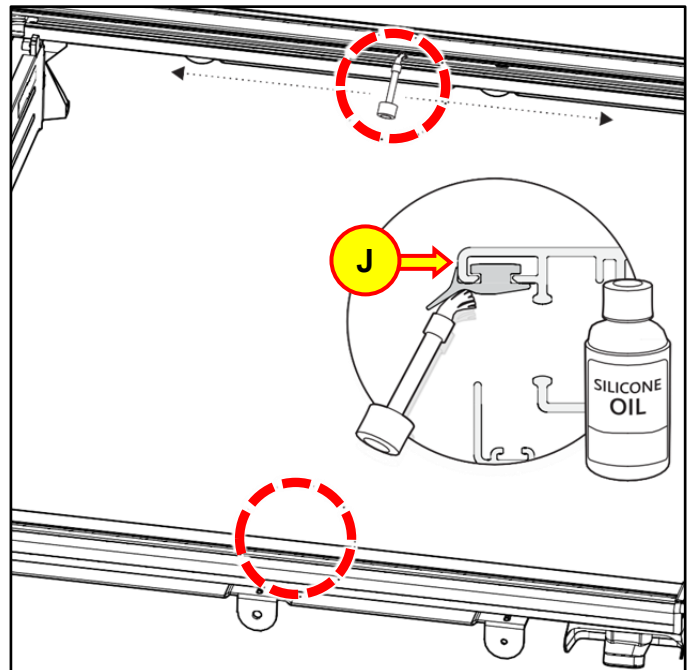

9. Remove the **2 clips (K)** from the front lamella.

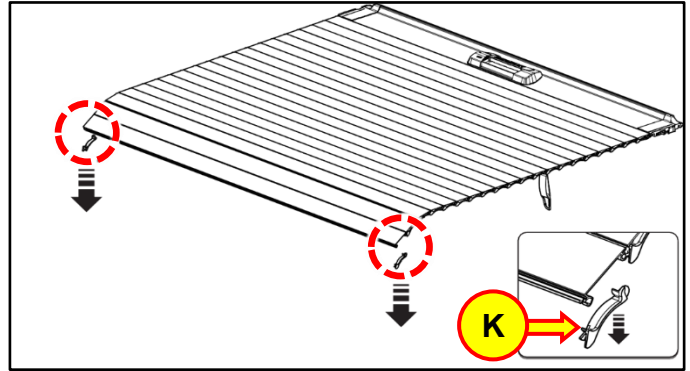

10. Remove and discard the old rubber straps from the tonneau cover.



11. Slide the **3 axle connector clips (L)** onto the **3 new rubber straps (M)**.

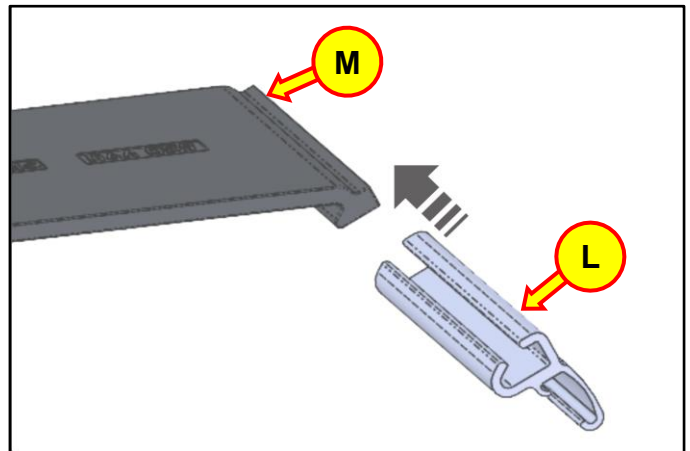

12. Slide the new rubber straps (N) into the front lamella.

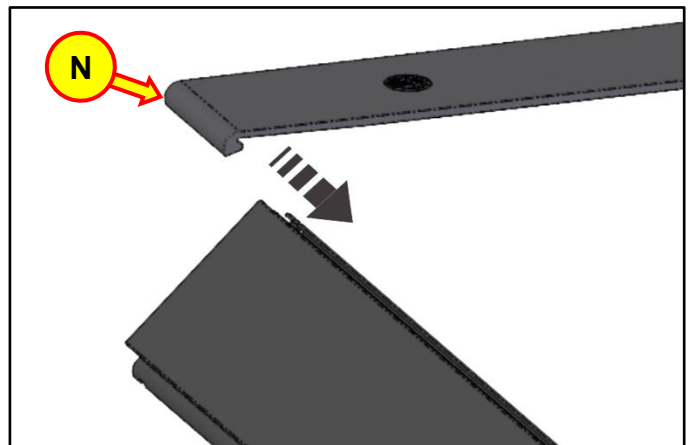

13. Evenly space the rubber straps (O) on the lamella.

**i Information**

The center rubber strap should be within **~2 inches** from the center.

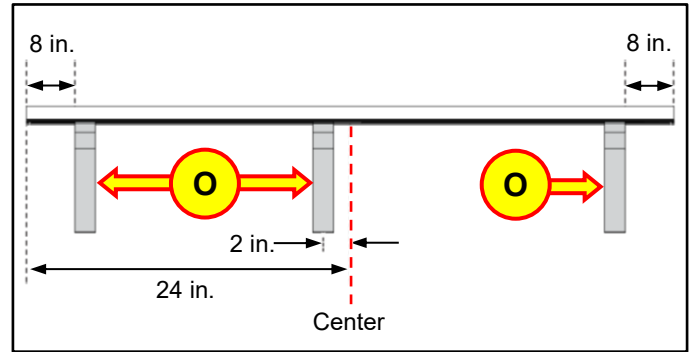

14. Remove the remaining old clips and replace **ALL** removed clips with new clips (P).

**i Information**

Install **20** clips (**40** total) on each side. The right clips are marked with “**R**”, and the left clips are marked with “**L**”.

**i Information**

The circular end of the clip should be oriented towards the rear of the vehicle.

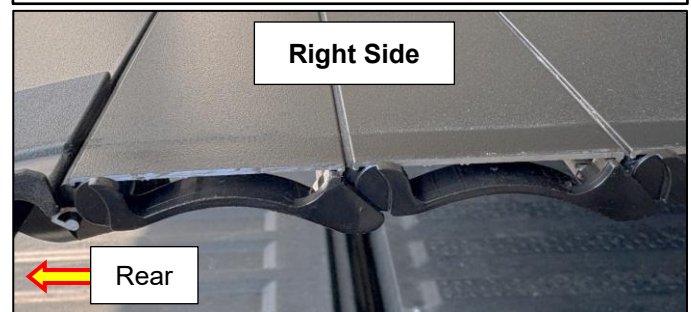
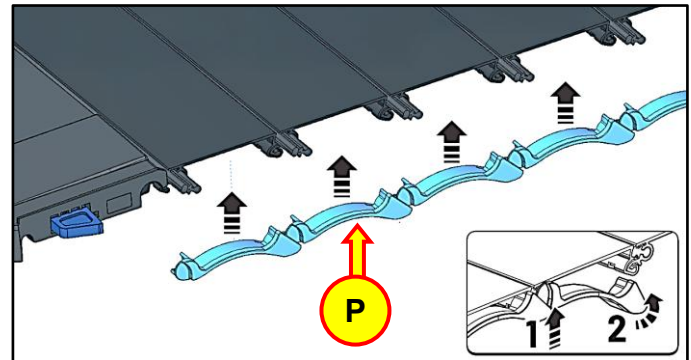

15. Reinstall the tonneau cover but leave the first two lamellas outside of the track.

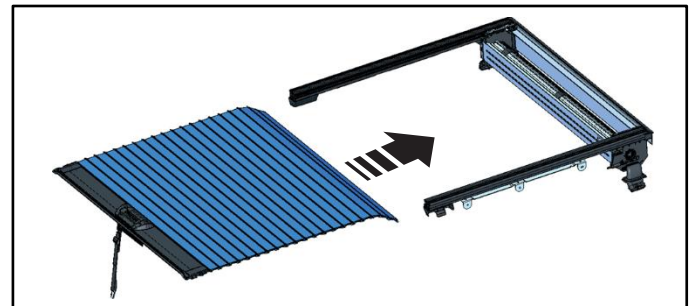

16. Evenly space the new rubber straps (Q) on the axle adjacent to the removed rubber straps.

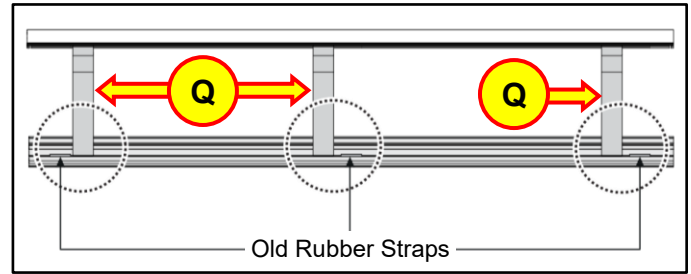

17. Press the connector down onto the axle until it snaps into place.

**i Information**

An audible “click” should be heard when the connector snaps onto the axle.

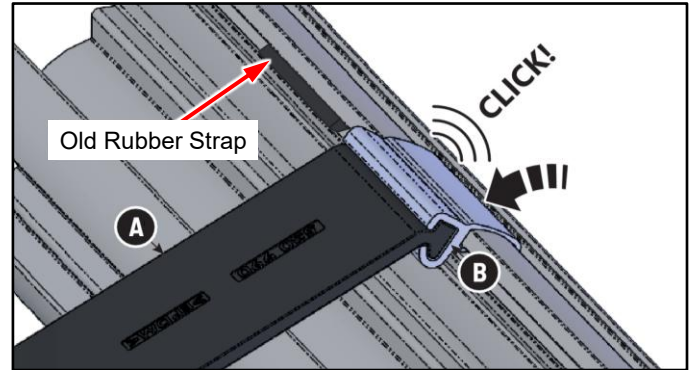

- 18.

**DIGITAL DOCUMENTATION**



Using the STUI camera function, take a photo showing the 3 straps with metal connectors installed on the axle.

Upload the photo to STUI.

**NOTE:** If the STUI camera function is **NOT** used, write the last 6 digits of the VIN and date of repair on a piece of paper to include in the photo.

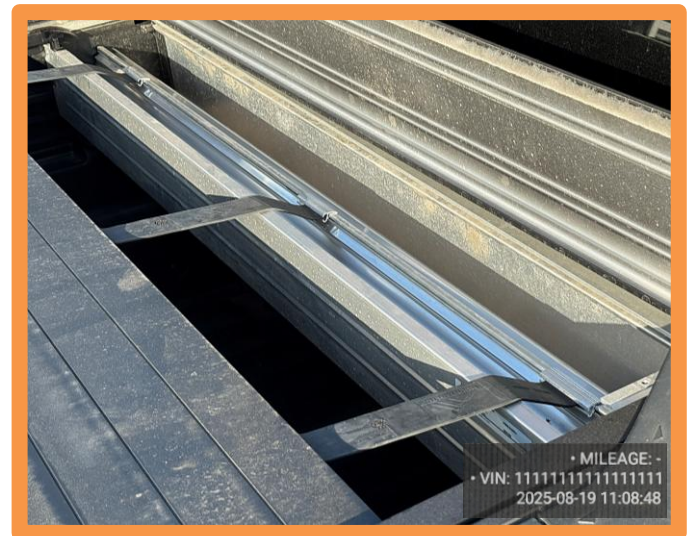

19. Carefully release the metal tension lock (R) between the axle and canister, allowing the cover to return to its tensioned position.

**i Information**

The rear profile should **NOT** roll all the way into the canister.

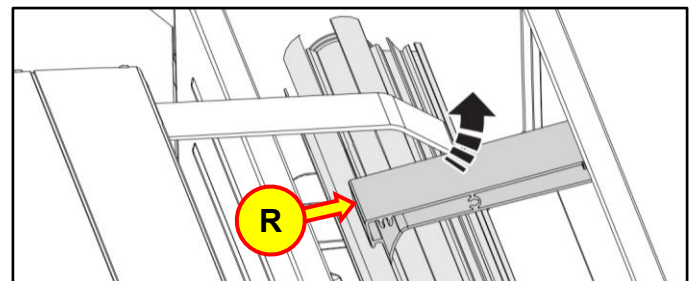

20. Slide the remaining section of the tonneau cover back into the tracks.



21. Reassemble the end caps on both sides of the vehicle.

**Tightening Torque:**

lb-ft	1.1
lb-in	13
N.m	1.5

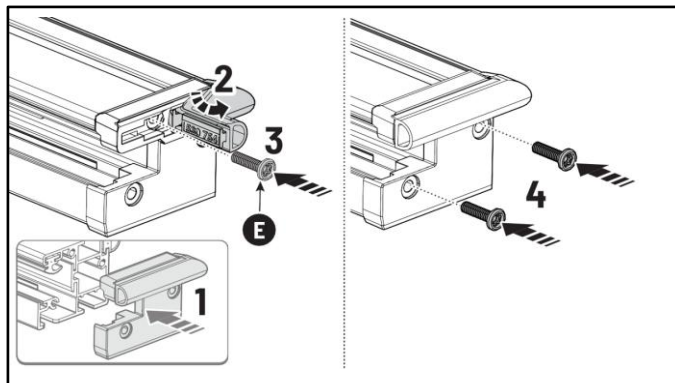

**i Information**

Slide the rubber cover into the slot to cover the 3<sup>rd</sup> screw.

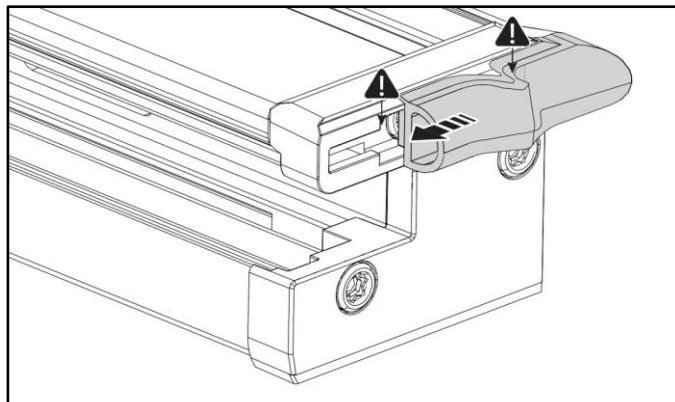

**i Information**

The lower seal **MUST** overlap the end cap, not be underneath.

The upper seal **MUST** be completely flush with the end caps.

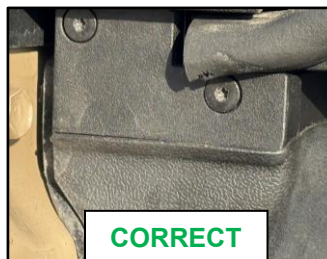

22. Close the tonneau cover lid (S) then tighten the two 3 mm bolts (T).

**Tightening Torque:**

lb-ft	1.3
lb-in	16
N.m	1.8

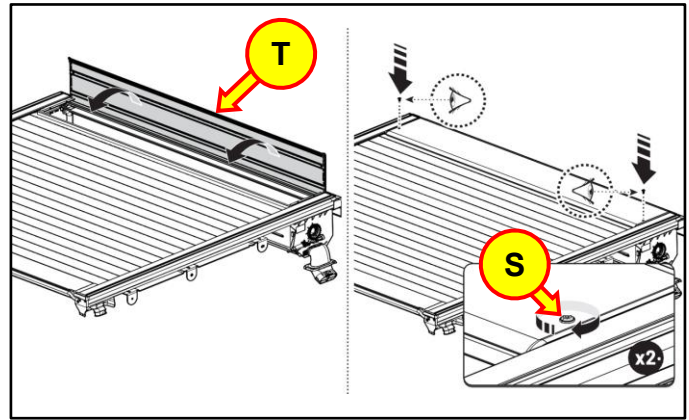

23. Confirm the tonneau cover properly operate.

**NOTICE**

Ensure the cover does **NOT** retract too fast and slam into the canister.

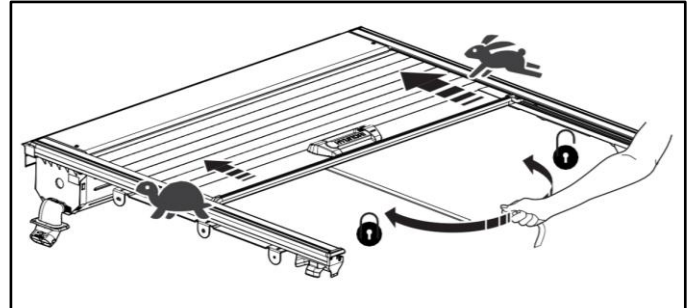

24. If necessary, adjust the tension of the spring by pressing and turning the knob, **right** to tighten (increase speed), and **left** to loosen (decrease speed).

**NOTICE**

Ensure the cover does **NOT** retract too fast and slam into the canister.

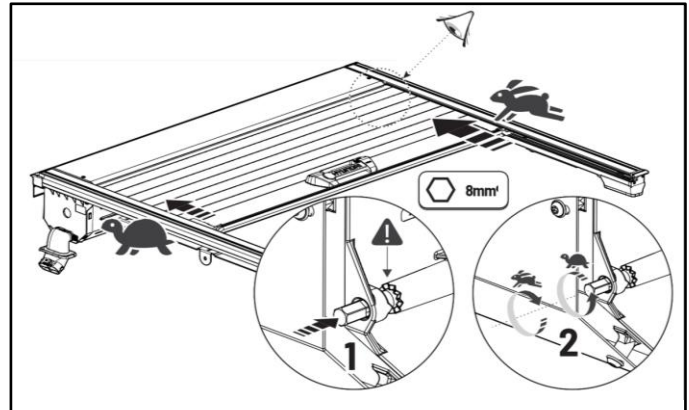

**NOTICE**

Do **NOT** use a power tool for this adjustment.

**NOTICE**

Make sure the tension knob (U) is pushed all the way in to prevent damaging the plastic teeth when turning.

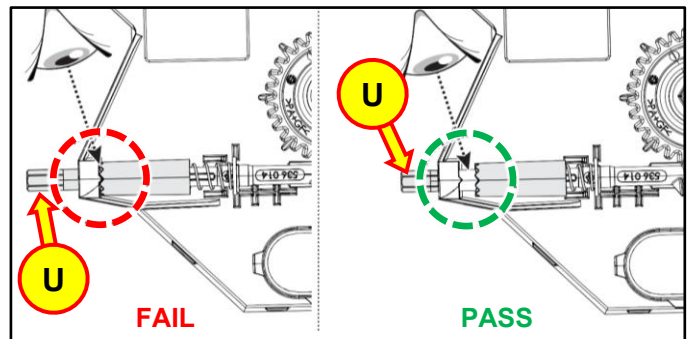

25. Verify proper tonneau cover operation and that **NO** V-gap exists (if applicable).

## Proper Tonneau Cover Operation

### **i** Information

Inform the customer how to properly operate the tonneau cover using the tips below.

- **ONLY** use the pull strap or center handle to close the tonneau cover.
- The tonneau cover should **ONLY** be closed by pulling from the center.
- Do **NOT** pull from the sides.
- Alignment / retraction problems may occur if the tonneau cover is repeatedly improperly closed.

### NOTICE

Do **NOT** slam the tonneau cover closed with excessive force. This may cause damage to the cover.

- Secure the pull strap (A) to either side of the bed when **NOT** in use.
- Pulling the strap to the left will reset the latch center handle position.

