

TECHNICAL SERVICE BULLETIN



DEPARTMENT OF COMPLIANCE
VEHICLE SAFETY AND RECALL MANAGEMENT
PO Box 30
MIDDLEBURY, INDIANA 46540-9218

Technical Service Bulletin: 300-2011
Service Campaign: 001263

- o Integrity
- o Safety
- o Quality
- o Customer Service

<<VIN>>
<<OWNER NAME/DEALERNAME>>
<<ADDRESS>>
<<CITY>>, <<ST>> <<ZIP-XXX>>

December 2025

Dear Forest River Customer:

Forest River is alerting you to an issue involving certain 2026 Aurora & Catalina Travel Trailer Recreational Vehicles. Please see the information below, which describes the issue and provides you with details on the steps you should take to have your vehicle repaired.

WHAT IS THE ISSUE?

The water heater may not have been properly winterized. If the water heater is not properly winterized, it may leak water due to cracked internal parts.

DEALERS: WHAT SHOULD YOU DO?

Remedy Instructions can be found on Dealer Connect.

HELPFUL CONTACT INFORMATION:

CONTACT	PHONE
CUSTOMER SERVICE	(574) 825-4995

Repair Codes:

Pictures are required for the remedy and/or inspection after installation.

Pictures of the remedy are a condition of payment in which must be provided with a claim against the repair code(s).

DEALER REPAIR CODES: Dealer Connect

TSB NUMBER	REPAIR CODE	DESCRIPTION	ALLOWABLE HOUR(S)
300-2011	SB-657-05-00-004775	INSPECTION ONLY	.10 HRS.
300-2011	SB-657-09-00-004776	INSPECTION AND REMEDY	.20 HRS

Sincerely,

Forest River, Inc.
Office of Corporate Compliance

TECHNICAL SERVICE BULLETIN 300-2011 REMEDY INSTRUCTIONS

 FOREST RIVER	Make(s): AURORA & CATALINA Model(s): MANY, SEE BELOW Model Year(s): 2026	Repair Code: SB-657-09-00-004776 Allotted Time: .20 HRS. Inspection Code: SB-657-05-00-004775 Allotted Time: .10 HRS.
	Concern: The water heater may not have been properly winterized.	Photo(s) Required: NO Prior Authorization Required: YES Part(s) Number: N/A Part(s) Return: N/A

Turn off LP Gas at LPG Tank(s). Disconnect the vehicles' battery Positive and Negative, disconnect any House battery(s) Positive and Negative, if equipped with a generator ensure it is off and lastly, ensure the vehicle is disconnected from shore power. Block any tires/wheels to prevent the vehicle from rolling. Failure to do so may result in electrocution, fire or other personal injury, property damage and/or death.

CERTAIN 2026 – AURORA & CATALINA TRAVEL TRAILERS

PLEASE FIND THE ATTACHED WINTERIZATION INSTRUCTIONS FOR THE GE TANKLESS WATER HEATER INSTALLED ON THE VEHICLE.

- THIS PROCEDURE WAS TAKEN DIRECTLY FROM PAGE 7 OF THE GE TANKLESS WATER HEATER MANUAL AVAILABLE ONLINE UNDER APPLIANCES FOR THE VEHICLE.
- IF THE VEHICLE REQUIRES WATER HEATER WINTERIZATION, PLEASE FILE THE REMEDY CLAIM;

Care and Cleaning

Routine Inspection

Routine inspection is critical for maintaining proper operation of your appliance. Unless specified, review the following items yearly or before each season:

1. Have the gas system and installation inspected by a qualified individual every 2 years, or as otherwise specified by your RV coach manufacturer.
2. Inspect for cracks, separation, and peeling of seals to the RV wall. Remove caulking or tape and re-seal as necessary between the side wall and the water heater to ensure that the unit is solidly mounted to the vehicle.
3. Verify that the air inlet openings (louvers) are completely open and clear of any debris including mud, leaves, twigs, insects, etc. Remove all obstructions to allow full air flow.
4. Insects, including wasps and spiders, can build nests in the exhaust tube outlet which will affect the performance of the unit. Inspect the flue outlet tube to make sure that it is unobstructed and that the screen is clean. If debris or insects are present, clean and vacuum to remove any remaining debris. The use of any type of after-market screen to cover the vent is not permitted and will void the warranty.
5. Open the door and verify that no debris or extraneous combustible materials are present anywhere (especially in the area of the burner and gas controls). Remove any item present and wipe clean the bottom of the housing.
6. Inspect the interior surface of the housing for any cracks or corroded areas that could allow penetration of gases into or out of the interior of the vehicle. Check especially around the hot water, cold water, gas and electrical connections.
NOTE: If damages found, please contact a technician to repair or contact GE Appliances service team.
7. Check that all wire connections are firmly in place and there are no signs of chafing or cracks on the insulation. Verify that the spark ignition cable between the Control Board and the igniter is securely in place and not shorted to any metal component.
8. Inspect the pressure safety valve to ensure it has not been leaking (no water residue). See Pressure Safety Valve Maintenance section for further inspection.
9. Inspect/Clean/replace water inlet filter as necessary, see Filter Cleaning section.
10. Turn on the power to the water heater and open a hot water faucet to inspect the flame of the burner. The flame should be of the normal bluish appearance that indicates proper combustion. This

can be accomplished by removing the water heater door and baffle to observe the flames by looking at the burner under the edge of the heat exchanger.

Hard Water and Decalcification

For prolong usage, when exposed to higher water hardness concentrations, it is advised to provide a proper water treatment device for the incoming water to the coach. Hard water may lead to performance reduction of your appliance overtime.

Winterizing the Water Heater

⚠ CAUTION FROST DAMAGE

In frost conditions, ambient temperatures below 39°F (4°C), there is a risk that water in pipes, faucets, and appliances could freeze. This can cause considerable damage.

Follow the instructions provided by the RV coach manufacturer for winterizing your water system. Supplement the following important water heater instructions when completing any winterizing steps:

Compressed Air

- DO NOT exceed 30 PSI into the water heater.
- While completing the blowout process for the entire water system, take time to isolate the water heater by closing all drain plugs and faucets and only open the water heater drain valve. This ensures maximum pressure and flow is isolated through the water heater of complete evacuation.

Anti-Freeze

- Make sure to exhaust all of the water.

Next Season

- Thoroughly flush the water heater and system with clean drinking water through the hot and cold side before using. Drain water several times out of the water heater drain valve. Sanitize the water system per the recommendations of your coach manufacturer.

Filter Cleaning

There is a filter screen on the water heater inlet water line connection.

The filter screen needs to be cleaned periodically to prevent blockages from forming.

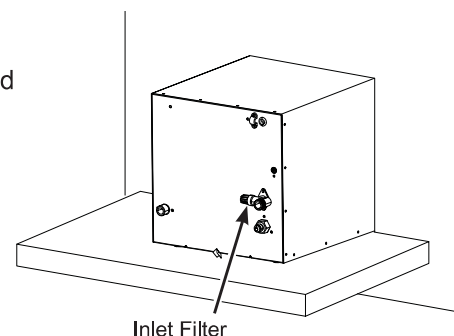

TECHNICAL SERVICE BULLETIN



DEPARTMENT OF COMPLIANCE
VEHICLE SAFETY AND RECALL MANAGEMENT
PO Box 30
MIDDLEBURY, INDIANA 46540-9218

Technical Service Bulletin: 300-2011

- o Integrity
- o Safety
- o Quality
- o Customer Service

<<VIN>>
<<OWNER NAME/DEALERNAME>>
<<ADDRESS>>
<<CITY>>, <<ST>> <<ZIP-XXX>>

December 2025

This Notice applies to your vehicle VIN listed above.

Dear Forest River Customer,

Forest River is alerting you to an issue involving certain 2026 Aurora & Catalina Travel Trailer Recreational Vehicles. Please see the information below, which describes the issue and provides you with details on the steps you should take to have your vehicle repaired.

WHAT IS THE ISSUE?

The water heater may not have been properly winterized. If the water heater is not properly winterized, it may leak water due to cracked internal parts.

OWNERS: WHAT SHOULD YOU DO?

Please contact your dealer immediately and request a service appointment to schedule the free repair. The vehicle Owner is responsible for arranging to have the work completed. Please state you have been notified by Forest River of the issue and provide the TSB number (located at the top of this page) to the dealership. It is also helpful to give the dealership a copy of this letter when you take your vehicle in for the repair.

You may visit www.forestriverinc.com to search for dealer locations.

HOW LONG WILL THE REMEDY PROCESS TAKE?

The estimated time of repair is .20 hours. However, the dealership may need to keep your vehicle or schedule an appointment with you for a later date to fit into their regular service schedule.

HELPFUL CONTACT INFORMATION:

CONTACT	PHONE
CUSTOMER SERVICE	(574) 825-4995

WHAT IF YOU HAVE PREVIOUSLY PAID FOR REPAIRS TO YOUR VEHICLE FOR THIS PARTICULAR CONDITION?

If you have already paid for a repair that is within the scope of this service bulletin, you may be eligible for a refund of previously paid repairs. Refunds will only be provided within the scope of this Technical Service Bulletin.

Please send the service invoice to the following address:

Aurora & Catalina
Forest River, Inc
Attn: Warranty Manager
423 N Main St
Middlebury, IN 46540

Sincerely,

Forest River, Inc.
Office of Corporate Compliance