

TITLE: 2024 ~ 2025 ZX636J/K OIL & FILTER CHANGE

FACTORY AUTHORIZED REPAIR

REPAIR ONLY AS REQUIRED

NOTICE
THIS BULLETIN ONLY APPLIES TO MOTORCYCLES THAT WERE ELIGIBLE FOR RECALL MC25-08 AND NOT REPAIRED.

Eligibility

Eligible Units

Year	Model Name	Model Code
2024	NINJA® ZX™-6R ABS	ZX636JRFAL
	NINJA® ZX™-6R ABS KRT EDITION	ZX636JRFAL
	NINJA® ZX™-6R ABS	ZX636JRFAN
	NINJA® ZX™-6R ABS KRT EDITION	ZX636JRFAN
	NINJA® ZX™-6R KRT 40TH ANNIVERSARY EDITION ABS	ZX636JRFBL
	NINJA® ZX™-6R KRT 40TH ANNIVERSARY EDITION ABS	ZX636JRFBN
	NINJA® ZX™-6R	ZX636KRFAL
	NINJA® ZX™-6R	ZX636KRFAN
	2025	NINJA® ZX™-6R ABS
NINJA® ZX™-6R ABS KRT EDITION		ZX636JSFAL
NINJA® ZX™-6R ABS		ZX636JSFAN
NINJA® ZX™-6R ABS KRT EDITION		ZX636JSFAN
NINJA® ZX™-6R		ZX636KSFAL
NINJA® ZX™-6R KRT EDITION		ZX636KSFAL
NINJA® ZX™-6R		ZX636KSFAN
NINJA® ZX™-6R KRT EDITION		ZX636KSFAN

Verify individual vehicle eligibility using VIP in K-Dealer before starting the repair.

Please check VIP (Vehicle Information Portal) in K-Dealer for other possible repair campaigns for eligible units.

Subject

Owners that did not have recall repairs completed under recall MC25-08 require an oil change under recall MC25-11.

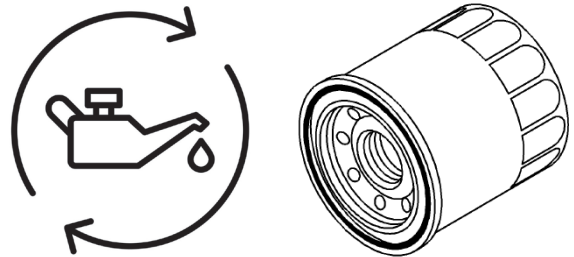

Kawasaki Action

Initiate Campaign:

Kawasaki has initiated an FAR campaign to perform an oil and filter change on all eligible customer owned motorcycles that were not repaired under recall MC25-08.

Dealer Action

Repair Eligible Units:

Replace engine oil and filter using genuine Kawasaki parts as listed in the claim section of this bulletin.

Repair Procedure

NOTICE

ONLY Complete this repair during the MC25-11 Recall Repair on all retailed units that were not repaired under recall MC25-08. Verify eligibility in K-Dealer before proceeding.

- Remove the engine oil drain bolt [A] to drain the oil.
- Replace the drain bolt gasket [B] with a new one.
- Install the drain bolt and tighten to 21 ft·lb (3.0 kgf·m, 29 N·m).

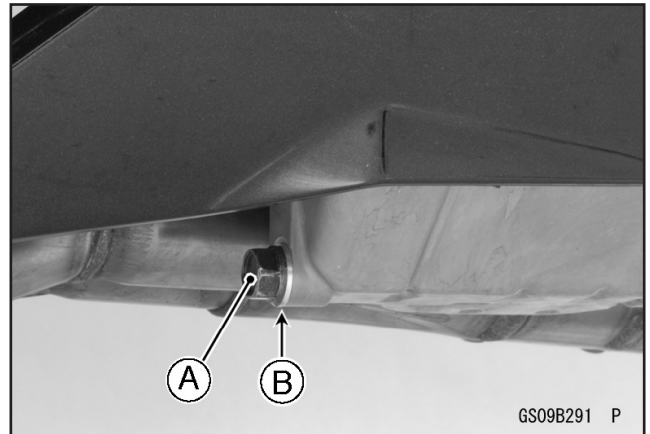

- Remove the oil filter [A] with oil filter wrench [B] 57001-1249 or with a suitable substitute.

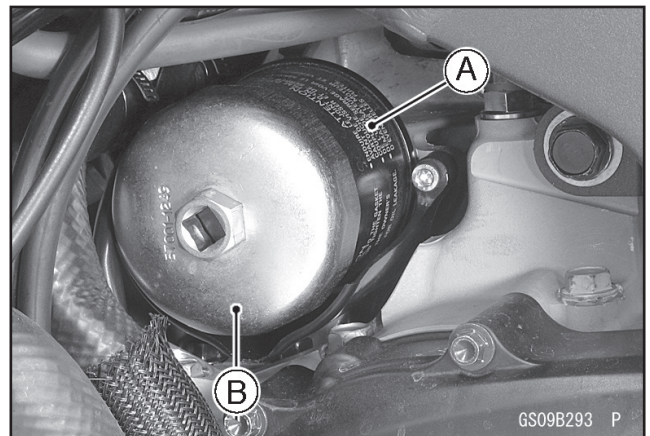

NOTE:

- Do not tighten the oil filter by hand.
- Apply grease to the gasket [A] on the new filter before installation.
- Tighten filter with oil filter wrench 57001-1249, or with a suitable substitute, to 13 ft·lb (1.7 kgf·m, 17 N·m).

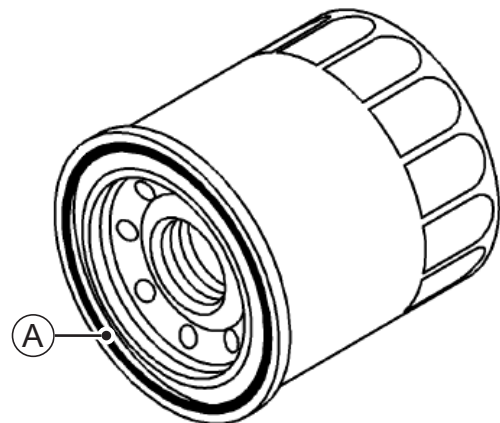

Repair Procedure

- Remove the oil filler plug [A].
- Pour in the specified type and amount of oil.
Engine Oil:
 - Type: Kawasaki Performance 4-Stroke, Full Synthetic
 - Viscosity: 10w-40
 - Capacity: 3.3 quarts (with filter change).
- Install the oil filler plug.

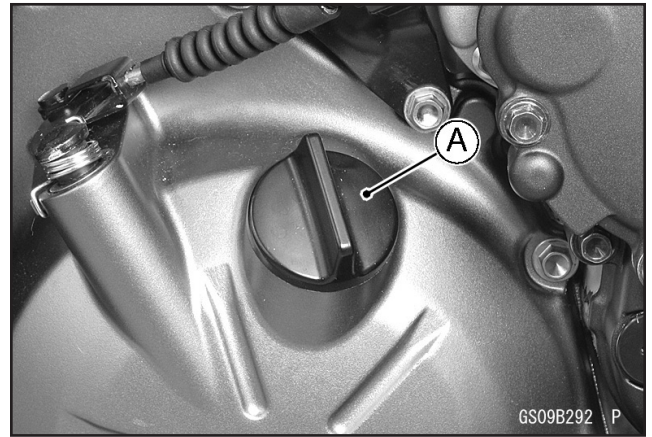

- Check that the engine oil level is between the upper [A] and lower [B] levels in the oil level inspection window.

NOTE:

- Situate the motorcycle so that it is perpendicular to the ground.
- If the oil has just been changed, start the engine and run it for several minutes at idle speed. This fills the oil filter with oil. Stop the engine, then wait several minutes until the oil settles.

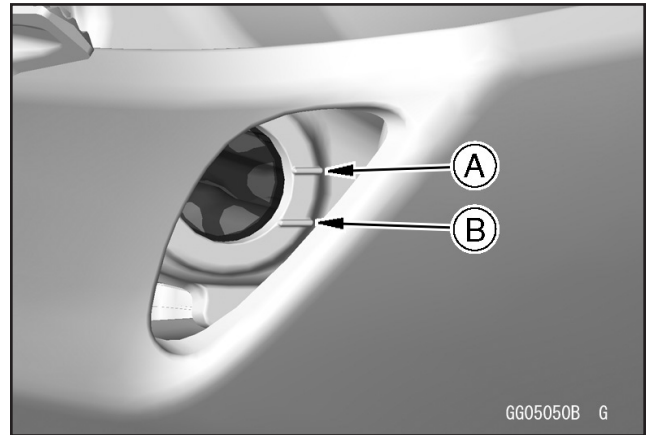

Warranty Information

NOTICE

SUBMIT A TYPE 2 CLAIM FOR THIS REPAIR.

Verify eligibility using VIP in K-Dealer before starting the repair.

Please check VIP (Vehicle Information Portal) in K-Dealer for other possible repair campaigns for eligible units.

Procedure	Change Oil Filter & Engine Oil
Job Code	21607
Flat Rate Time	0.2 hrs
Claim Type	2
Part Number	99999-0998
Description	Kit, MC25-11
Quantity	0
Additional Parts	16097-0008 FILTER-ASSY-OIL Qty=1 92065-097 GASKET, 12X22X2 Qty=1 K61021-500-01Q KPO FS MC 10W40 (QT) Qty=4