



Maserati

PERSONAL SERVICE LAB

MASTERS OF CARE

MC20 / GranTurismo / GranCabrio – Fuel Tank Pump Kits

DATE: December 19, 2025

This bulletin provides updated information regarding the serviceability of the in-tank fuel pumps for MC20, GranTurismo, and GranCabrio.

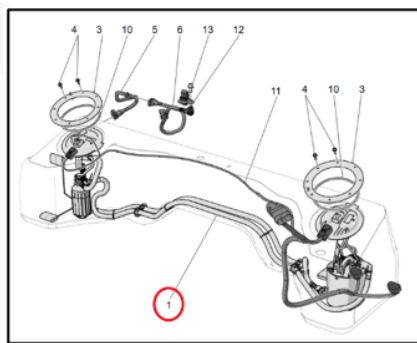

MC20

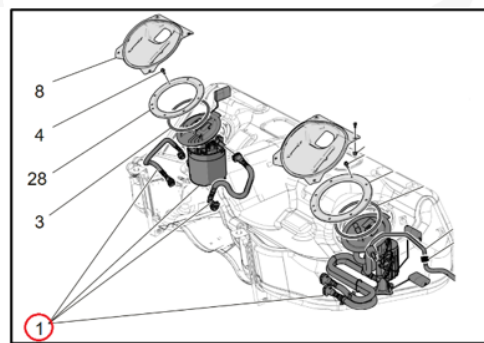

GT/GC

Issue Description

If an in-tank fuel pump and/or fuel level sensor malfunction required replacement, the complete fuel tank previously had to be replaced because these components were not available separately.

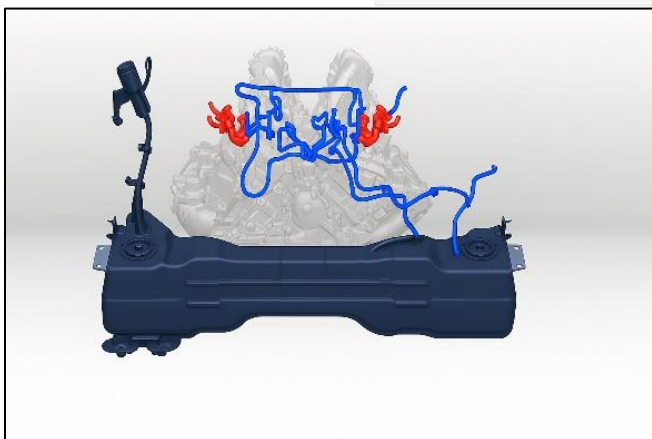

MC20 Fuel Tank

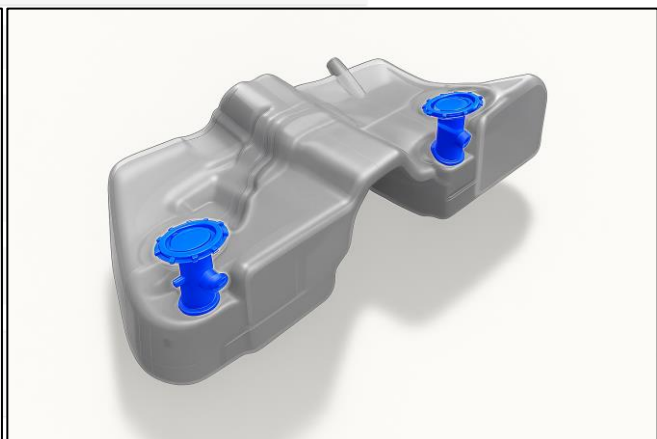

GT/GC Fuel Tank

The fuel pump kit is now available as an individual service sub-component, allowing replacement of the fuel pump assembly without replacing the entire fuel tank.

Affected Models

- (M240) MC20 ALL MY
- (M189) GranTurismo / (M190) GranCabrio ALL MY

Available Components

The following spare part numbers are now available:

- For MC20 – P/N #670305454: FUEL DELIVERY MODULE KIT (component #1 in Section 01.43-1 of the Spare Parts Catalog).
- For GranTurismo / GranCabrio – P/N #670354863: FUEL DELIVERY MODULE KIT (component #1 in Section 01.43-1 of the Spare Parts Catalog).

🔧 Note: Always refer to the latest Technical Documentation to confirm correct part application.

Workshop Procedure

The replacement procedure is published in the Technical Documentation:

- #1.43.001 – COMPLETE RH FUEL PUMP (Removal-Refit or Replacement).
- #1.43.002 - COMPLETE LH FUEL PUMP (Removal-Refit or Replacement).

Special Tools: Not required.

For any further clarification, please do not hesitate to contact us.

Best regards.

TECHNICAL SERVICE OPERATIONS