

Field campaign

Topic	Titanium sports exhaust system - Clamp Installation Bentayga 26MY (SC25/44)
Market area	Germany E02 Bentley rest Europe (6E02),United States E05 Bentley USA and rest America (6E05)
Brand	Bentley
Transaction No.	2079821/2
Campaign number	ED72
Note	
Type	
US code	

Vehicle data

26MY Bentayga Speed

Sales types

Type	MY	Brand	Designation	Engine code	Gearbox code	Final drive code
4V1*	2026	E		*	*	*

Documents

Document name
master.xml
sc2544vinlist.pdf

ED72

Transaction No.: 2079821
/2

Titanium sports exhaust system - Clamp Installation | Bentayga | 26MY (SC25
/44)

Release date: Nov 14, 2025

Notes

▼ **Repair instructions**

Technical background

Affected vehicles have been identified for a containment action with regards to the Titanium Sports Exhaust. Through vehicle testing phases, a potential concern has been identified where a customer may experience a rattle in their exhaust system when the vehicle reaches 30,000–40,000 kms. Clamp brackets are required to be installed to mitigate this potential concern.

2079821/2

Warranty accounting instructions – LOT (Labour Operation) Code update

Remedy

Install 2x exhaust clamps per vehicle using approved parts. Please refer to the *Work section* and conduct all instructions to completion

Customer notification

Customers do not need to be informed directly of this campaign.

Ensure all affected vehicles are repaired during Pre-Delivery Inspection (PDI).

Or

In the event that vehicles have been handed over to the customer please note that customer notification is not required, in this scenario please ensure the work is conducted at the nearest opportunity

Warranty

Claim Type: 790 or 710

Service Number: ED72

Damage Code: 00 66

Labour Operation Code: 26 38 14 49 (*Live on 20.11.2025, use 26 38 23 99 prior to this date*)

Time: 20TU

Criteria ID: 01

Parts

Part Number	Description	Quantity
-------------	-------------	----------

36A 253 317	REAR EXHAUST CLAMP BRACKET ASSEMBLY	1
36A 253 319	FRONT EXHAUST CLAMP BRACKET ASSEMBLY	1

Parts supply

NOTICE

IMPORTANT: Parts will be auto issued to affected retailers. Retailers do not need to order replacement parts.

Parts despatch control

NOTICE

IMPORTANT: Parts will be auto issued to affected retailers. Retailers do not need to order replacement parts.

Repair instructions



Technical background

Affected vehicles have been identified for a containment action with regards to the Titanium Sports Exhaust. Through vehicle testing phases, a potential concern has been identified where a customer may experience a rattle in their exhaust system when the vehicle reaches 30,000–40,000 kms. Clamp brackets are required to be installed to mitigate this potential concern.

2079821/2

Warranty accounting instructions – LOT (Labour Operation) Code update

Check

If the vehicle is not already listed as repaired in the 'Repair history' section of ElsaPro, check the 'Identification' section of this document. In the event that the campaign has not been applied, please carry out the required work in accordance with these instructions.

Parts

Part Number	Description	Quantity
36A 253 317	REAR EXHAUST CLAMP BRACKET ASSEMBLY	1
36A 253 319		1

	FRONT EXHAUST CLAMP BRACKET ASSEMBLY	
--	---	--

Work

General Information

WARNING

Before commencing work on and around the exhaust system, ensure that it has cooled sufficiently, failure to do so may cause injury to personnel. Always wear suitable PPE.

1. Position the vehicle on a ramp.

ElsaPro → Booklet 404

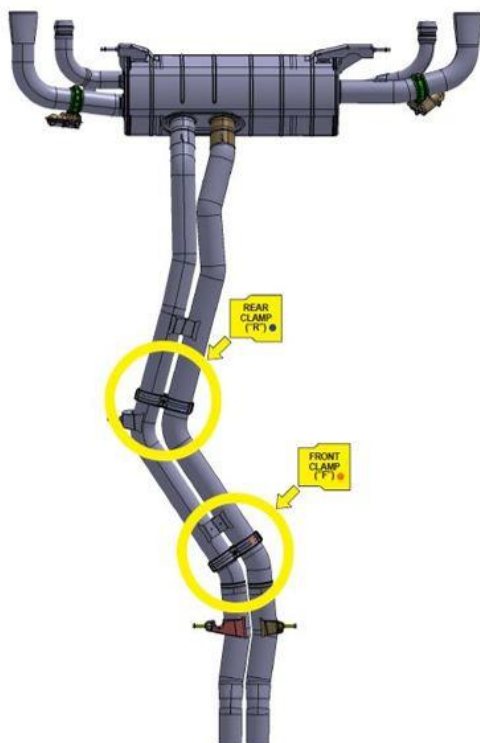

Figure 1. Bottom View of the exhaust system with clamps installed

2. Identify the front and rear clamp positions as per figure 1 diagram.

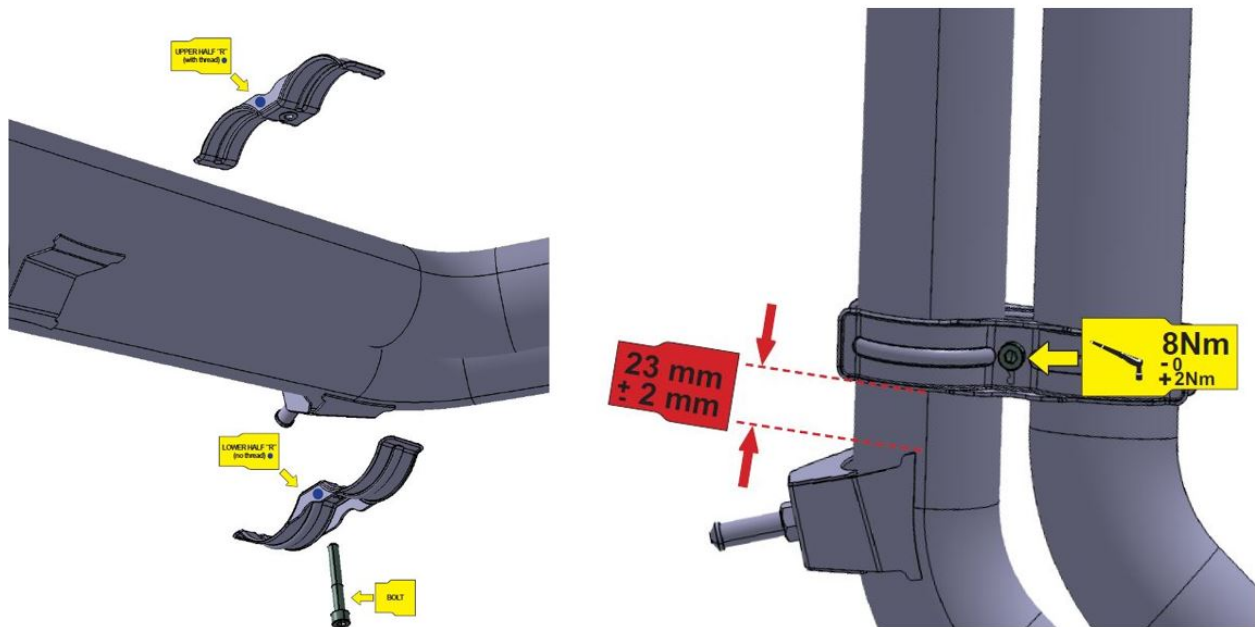

Figure 2 – Rear clamp positioning

3. Install the Rear Clamp.

- Position the lower half of the rear clamp (Marked with Engraving R and with **BLUE** dot). Beneath the exhaust pipe at the rear location. Align the upper half above the pipe and insert the bolts through both halves.
- Align the bracket 23 mm ± 2 mm from point as shown in figure 2.
- Hand-tighten bolts initially. Wiggle clamps gently to achieve ideal positioning.
- Using a manual torque wrench, torque the bolt to 8 Nm ± 2 Nm.

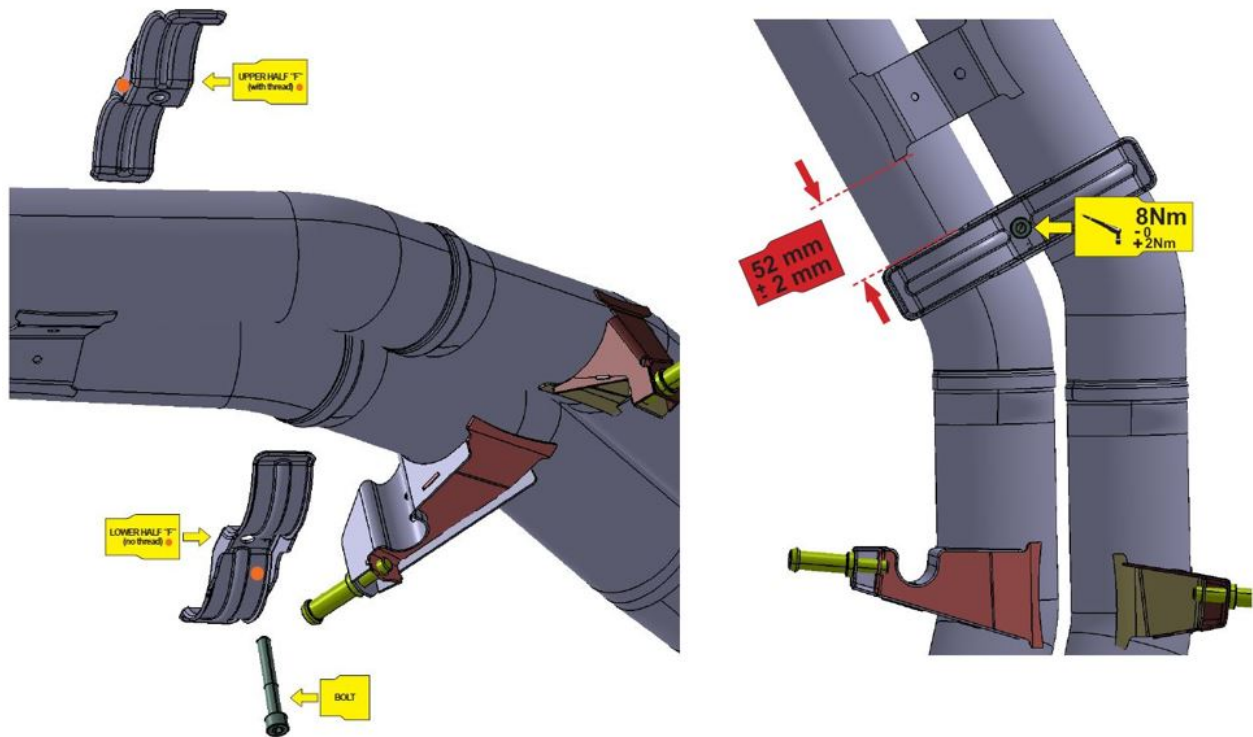

Figure 3. Front clamp positioning

4. Install the Front Clamp.

- Position the lower half of the front clamp (Marked with Engraving F and with **ORANGE** dot). Beneath the exhaust pipe at the front location. Align the upper half above the pipe and insert the bolts through both halves.
- Align the bracket 52 mm ± 2 mm mm from point as shown in figure 3.
- Hand-tighten bolts initially. Wiggle clamps gently to achieve ideal positioning.
- Using a manual torque wrench, torque the bolt to 8 Nm ± 2 Nm.

5. Final Checks

Ensure clamps are securely fastened.

Perform a pull-to-check to confirm stability.

Visually inspect for correct placement and marking.

Identification

Once the applicable action has been conducted, the operative must submit a warranty claim as this will show the service campaign action as complete within Elsa Pro "Repair history".

Fitment of the clamps as per Figure 4 below confirms campaign completion.

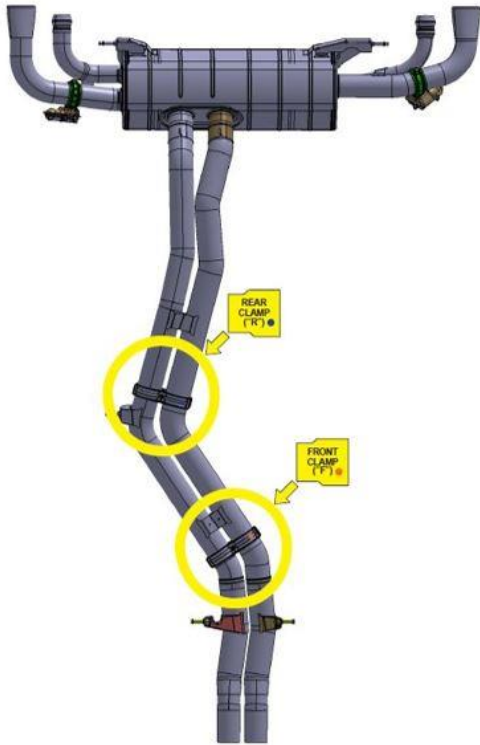

Figure 4 – Campaign completion

▲ Repair instructions ▲ Notes

SJAAE14V1TC032476
SJAAF2ZV0TC032464
SJAAF2ZV0TC032528
SJAAF2ZV1TC032425
SJAAF2ZV3TC032474
SJAAF2ZV4TC032550
SJAAF2ZV5TC032539
SJAAF2ZV6TC032386
SJAAF2ZV6TC032534
SJAAF2ZV7TC032526
SJAAF2ZV8TC032549
SJAAF2ZV9TC032530
SJAAF2ZVXTC032486
SJAAF2ZV1TC032439
SJAAF2ZV2TC032434