

# Technical Service Bulletin

Mazda North American Operations  
Irvine, CA 92618-2922



<b>Subject:</b>  FUEL-FILLER LID CANNOT BE LOCKED AFTER AUTO-LOCK TIME HAS EXPIRED	<b>Bulletin No.:</b> 09-042/25
	<b>Last Issued :</b> 11/19/2025

## BULLETIN NOTES

This bulletin supersedes the previously issued bulletin(s) listed below. The changes are noted in Red.

Previous TSBs:	Date(s) Issued:
09-027/24	05/13/24
09-004/23	01/09/23
09-006/22	03/01/22

## APPLICABLE MODEL(S)/VINS

2019-2026 Mazda3 5HB (Japan built)  
2024-2026 Mazda3 5HB (Mexico built)  
2020-2026 CX-30 (Mexico built)

## DESCRIPTION

Some customers may experience that after the doors are locked and the Fuel Door Lock Delay with MAZDA CONNECT has passed (default setting is 90 seconds), the fuel-filler lid does not lock, but can be opened when pressed.

### NOTE:

- The fuel-filler lid does not lock immediately after the doors are locked, but after the time set in the Fuel Door Lock Delay (0, 30, 60, 90, and 120 seconds).
- Although the root cause has not been identified, the vehicle should be repaired by adjusting the fuel-filler lid opener cable position when there is a customer complaint.

Customers having this concern should have their vehicle repaired using the following repair procedure.

## REPAIR PROCEDURE

1. Verify the customer concern by locking the doors and pressing the fuel-filler lid after 2 minutes to see if it opens.
  - If the fuel-filler lid can be opened, adjust the fuel-filler lid opener cable position using the Adjustment Procedure of Fuel-Filler Lid Opener Cable below.

**CAUTION:** Be aware of sharp components around the fuel-filler lid opener cable. Be careful not to cut your hands or fingers on the sharp components.

2. After adjustment of the cable, wait for 2 minutes after locking the doors, then press the fuel-filler lid again to verify that

Page 1 of 6

**CONSUMER NOTICE:** The information and instructions in this bulletin are intended for use by skilled technicians. Mazda technicians utilize the proper tools/ equipment and take training to correctly and safely maintain Mazda vehicles. These instructions should not be performed by "do-it-yourselfers." Customers should not assume this bulletin applies to their vehicle or that their vehicle will develop the described concern. To determine if the information applies, customers should contact their nearest authorized Mazda dealership. Mazda North American Operations reserves the right to alter the specifications and contents of this bulletin without obligation or advance notice. All rights reserved. No part of this bulletin may be reproduced in any form or by any means, electronic or mechanical--including photocopying and recording and the use of any kind of information storage and retrieval system ---without permission in writing.

the lid does not open.

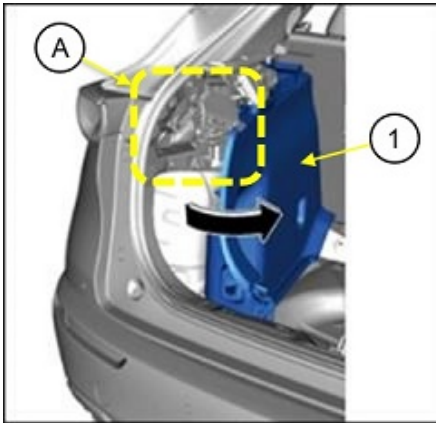

(1) Trunk side trim

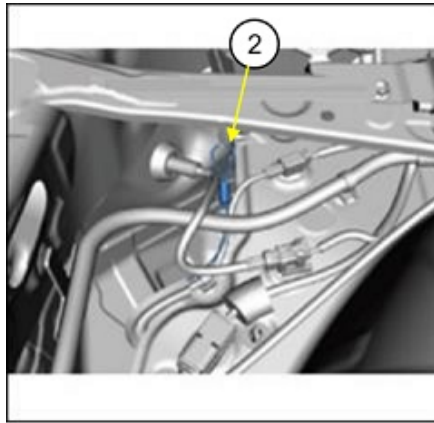

Detail A: (2) Fuel-filler lid opener cable

#### Adjustment Procedure of Fuel-Filler Lid Opener Cable

1. Remove the following parts according to the instructions on MGSS.

- Mazda3 (FUEL-FILLER LID LOCK ACTUATOR MANUAL RELEASE PROCEDURE)
- CX-30 (FUEL-FILLER LID LOCK ACTUATOR MANUAL RELEASE PROCEDURE)
  - Rear package tray
  - Trunk covering
  - Trunk board
  - Trunk end trim
  - Trunk side upper trim (LH)

2. Partially peel the trunk side trim (LH) (1).

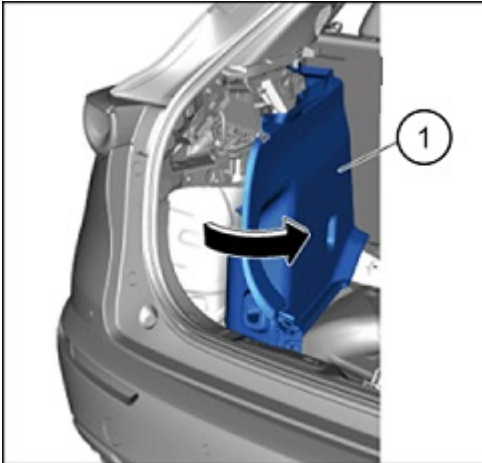

**CONSUMER NOTICE:** The information and instructions in this bulletin are intended for use by skilled technicians. Mazda technicians utilize the proper tools/ equipment and take training to correctly and safely maintain Mazda vehicles. These instructions should not be performed by "do-it-yourselfers." Customers should not assume this bulletin applies to their vehicle or that their vehicle will develop the described concern. To determine if the information applies, customers should contact their nearest authorized Mazda dealership. Mazda North American Operations reserves the right to alter the specifications and contents of this bulletin without obligation or advance notice. All rights reserved. No part of this bulletin may be reproduced in any form or by any means, electronic or mechanical---including photocopying and recording and the use of any kind of information storage and retrieval system ---without permission in writing.

3. Remove the trunk side insulator.

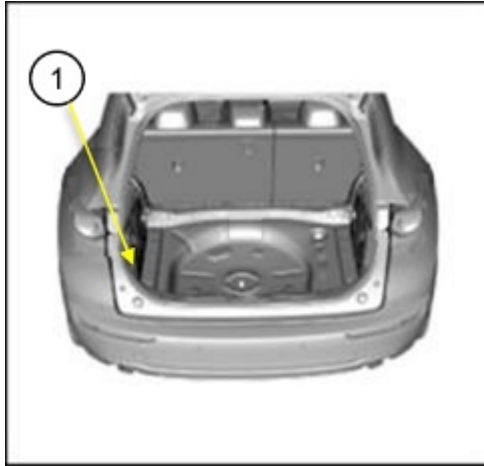

(1) Location of Trunk side insulator

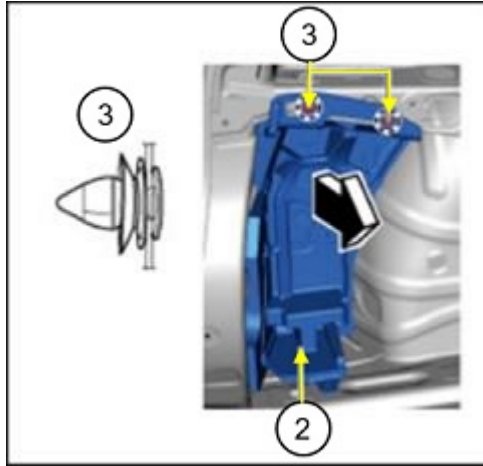

(2) Trunk side insulator  
(3) Clip (2pcs.)

4. Cut the zip tie securing the fuel-filler lid opener cable.



**CONSUMER NOTICE:** The information and instructions in this bulletin are intended for use by skilled technicians. Mazda technicians utilize the proper tools/ equipment and take training to correctly and safely maintain Mazda vehicles. These instructions should not be performed by "do-it-yourselfers." Customers should not assume this bulletin applies to their vehicle or that their vehicle will develop the described concern. To determine if the information applies, customers should contact their nearest authorized Mazda dealership. Mazda North American Operations reserves the right to alter the specifications and contents of this bulletin without obligation or advance notice. All rights reserved. No part of this bulletin may be reproduced in any form or by any means, electronic or mechanical---including photocopying and recording and the use of any kind of information storage and retrieval system ---without permission in writing.

5. Pull the fuel-filler lid opener cable (1) slowly to the end (manual release procedure). **NOTE:** DO NOT pull the cable with too much force, otherwise it could be damaged.

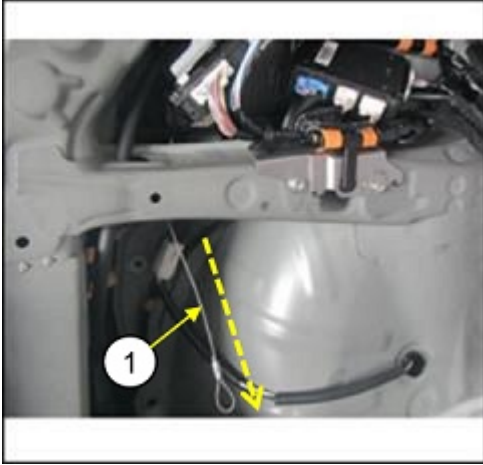

**TIP:** By pulling the cable (1), the lock connected to the opener lever (2) leaves the cam hole and the actuator rod (3) is unlocked.

Inside of Fuel-Filler Lid Lock Actuator

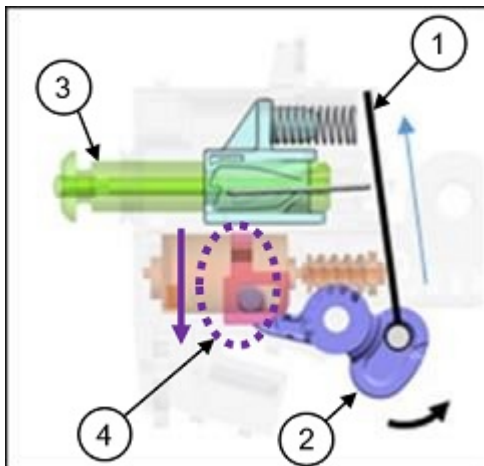

- (1) Opener cable
- (2) Opener lever
- (3) Actuator rod
- (4) Lock

**CONSUMER NOTICE:** The information and instructions in this bulletin are intended for use by skilled technicians. Mazda technicians utilize the proper tools/ equipment and take training to correctly and safely maintain Mazda vehicles. These instructions should not be performed by "do-it-yourselfers." Customers should not assume this bulletin applies to their vehicle or that their vehicle will develop the described concern. To determine if the information applies, customers should contact their nearest authorized Mazda dealership. Mazda North American Operations reserves the right to alter the specifications and contents of this bulletin without obligation or advance notice. All rights reserved. No part of this bulletin may be reproduced in any form or by any means, electronic or mechanical---including photocopying and recording and the use of any kind of information storage and retrieval system ---without permission in writing.

6. Secure the fuel-filler lid opener cable end (1) with another tie band (2) (return it to it's original position).

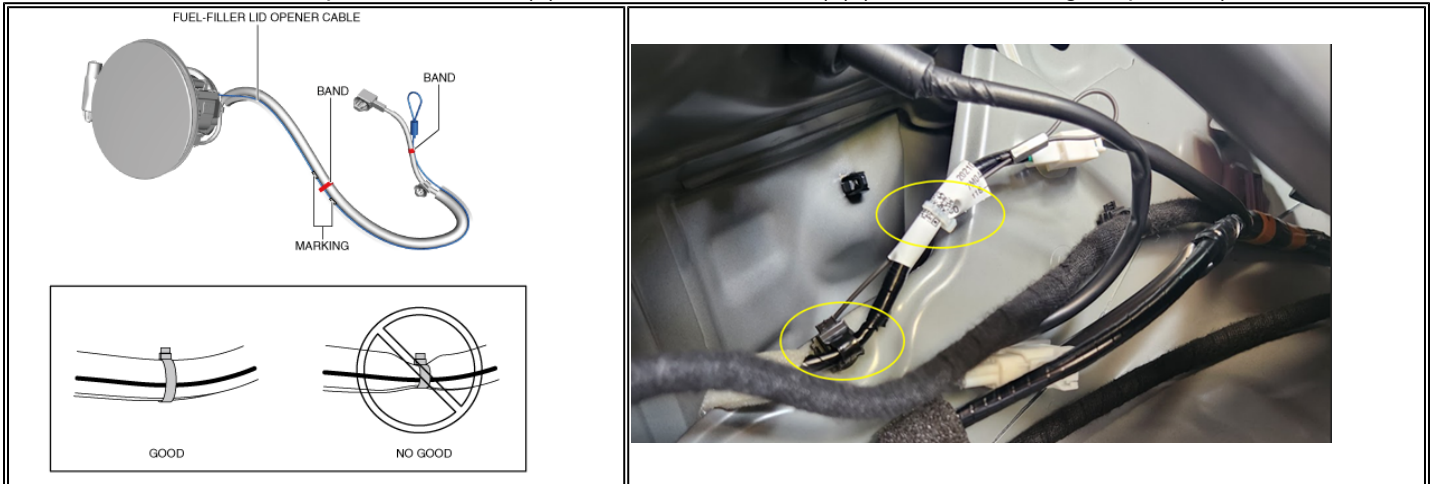

**NOTE:** The fuel lid opener cable should allow the lever to be in the "lock allowed" position and should not be putting any tension on the lever to put it into the "emergency unlock" position.

**TIP:** By pushing the opener cable (1), the lock connected to the opener lever (2) inserts into the cam hole and the actuator rod (3) is locked.

Inside of Fuel-Filler Lid Lock Actuator

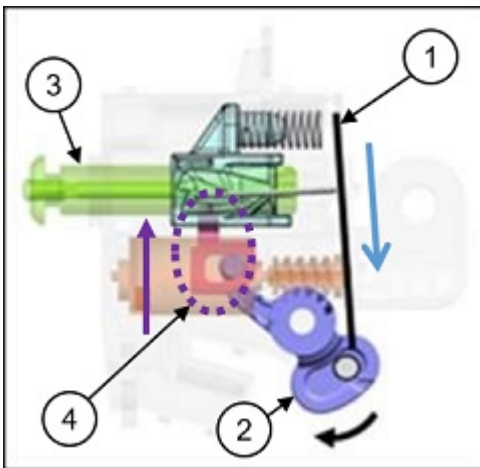

- (1) Opener cable
- (2) Opener lever
- (3) Actuator rod
- (4) Lock

7. Verify that the fuel-filler lid does not open after closing and locking the doors and liftgate for 2 minutes or more.

8. If the fuel filler lid does not lock after 2 minutes or more, replace the fuel filler lid assembly according to the instructions in MGSS:

CX-30 - FUEL-FILLER LID OPENER CABLE REMOVAL/INSTALLATION

Mazda3 - FUEL-FILLER LID OPENER CABLE REMOVAL/INSTALLATION

**NOTE:** Verify fuel filler assembly part number per VIN in GEPC (D-Code 42-240C).

9. Install the parts removed in step 1 in the reverse order of removal.

**CONSUMER NOTICE:** The information and instructions in this bulletin are intended for use by skilled technicians. Mazda technicians utilize the proper tools/ equipment and take training to correctly and safely maintain Mazda vehicles. These instructions should not be performed by "do-it-yourselfers." Customers should not assume this bulletin applies to their vehicle or that their vehicle will develop the described concern. To determine if the information applies, customers should contact their nearest authorized Mazda dealership. Mazda North American Operations reserves the right to alter the specifications and contents of this bulletin without obligation or advance notice. All rights reserved. No part of this bulletin may be reproduced in any form or by any means, electronic or mechanical--including photocopying and recording and the use of any kind of information storage and retrieval system ---without permission in writing.

**PARTS INFORMATION**

Parts Number	Description	Qty.	Notes
E120-68-AB1	Clip	1	[R] For trunk side upper trim (CX-30 only)

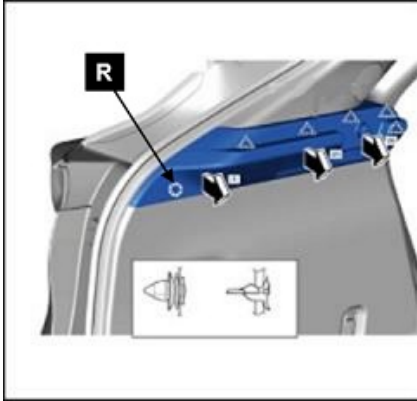
**WARRANTY INFORMATION****NOTE:**

- This warranty information applies only to verified customer complaints on vehicles eligible for warranty repair.
- This repair will be covered under Mazda's New Vehicle Limited Warranty term.
- Additional diagnostic time cannot be claimed for this repair.

Warranty Type	A
Symptom Code	42
Damage Code	9G
Part Number Main Cause	7777-SP-T30
Quantity	0
Operation Number / Labor Hours:	XXT5BARX / 0.3 Hrs.

**CONSUMER NOTICE:** The information and instructions in this bulletin are intended for use by skilled technicians. Mazda technicians utilize the proper tools/ equipment and take training to correctly and safely maintain Mazda vehicles. These instructions should not be performed by "do-it-yourselfers." Customers should not assume this bulletin applies to their vehicle or that their vehicle will develop the described concern. To determine if the information applies, customers should contact their nearest authorized Mazda dealership. Mazda North American Operations reserves the right to alter the specifications and contents of this bulletin without obligation or advance notice. All rights reserved. No part of this bulletin may be reproduced in any form or by any means, electronic or mechanical---including photocopying and recording and the use of any kind of information storage and retrieval system ---without permission in writing.