

# Technical Service Bulletin

Mazda North American Operations  
Irvine, CA 92618-2922



<b>Subject:</b>  SUNROOF RATTLE NOISE	<b>Bulletin No.:</b> 09-010/25
	<b>Last Issued :</b> 11/07/2025

## BULLETIN NOTES

This TSB supersedes the previously issued TSB(s) / SA(s) listed below. The changes are noted in Red.

Previous TSBs / SAs:	Date(s) Issued:	Previous SAs:	Date(s) Issued:
09-010/25	05/29/2025 and 02/19/25	SA-014/23	11/14/23, 07/11/23, 03/20/23 and 03/10/23
SA-001/24	02/21/24 and 01/05/24	SA-032/22	12/22/22 and 05/10/22

## APPLICABLE MODEL(S)/VINS

2023-2026 CX-50 (All)

## DESCRIPTION

Some customers may complain about a rattle from the sunroof (panorama roof) area. Make sure to read the complete repair procedure before attempting any repairs as the sunroof may have rattles from more than one location. The rattle noise may be caused by:

1. Looseness in the side cover fitting part
2. Looseness in the cross brace cover clip
3. Looseness in the movable part inside the sunroof unit

To eliminate this concern, the following changes have been implemented.

- CAUSE 1: The shape of the side cover and clips have been modified to reduce the movement causing the rattle noise
- CAUSE 2: Improvement of the assembly process
- CAUSE 3: Modification of dimensions of the moving parts

Customers having this concern should have their vehicle repaired using the following repair procedure.

**CONSUMER NOTICE:** The information and instructions in this bulletin are intended for use by skilled technicians. Mazda technicians utilize the proper tools/ equipment and take training to correctly and safely maintain Mazda vehicles. These instructions should not be performed by "do-it-yourselfers." Customers should not assume this bulletin applies to their vehicle or that their vehicle will develop the described concern. To determine if the information applies, customers should contact their nearest authorized Mazda dealership. Mazda North American Operations reserves the right to alter the specifications and contents of this bulletin without obligation or advance notice. All rights reserved. No part of this bulletin may be reproduced in any form or by any means, electronic or mechanical--including photocopying and recording and the use of any kind of information storage and retrieval system ---without permission in writing.

**REPAIR PROCEDURE**

1. Verify the customer concern.
2. Determine the vehicle type (A, B, or C) by using the table below.

Vehicle Type	VIN Range	Side Cover Rattle	Cross Brace Rattle	Sunroof Unit
A	Up to production date 06/29/23.	Follow Procedure A	Follow Procedure B	Follow Procedure C
B	After 06/29/2023 production and up to <b>7MMVABBM3SN361099</b> (produced before April 10, 2025)	Follow Procedure A	Contact Mazda Technical Hotline	Follow Procedure C
C	After <b>7MMVABBM3SN361100</b> (produced after April 11, 2025)	Contact Mazda Technical Hotline	Contact Mazda Technical Hotline	Follow Procedure C

**PROCEDURE A (FOR SIDE COVER RATTLE)**

The noise comes from the side cover vibrating against the assembly at the location marked by the arrow due to poor retention of the cover clips.

- 1) Test drive the vehicle, and if you hear the noise, press the edges of the side covers (6 total) as shown in the example below.

**Was the noise eliminated?**



**CONSUMER NOTICE:** The information and instructions in this bulletin are intended for use by skilled technicians. Mazda technicians utilize the proper tools/ equipment and take training to correctly and safely maintain Mazda vehicles. These instructions should not be performed by "do-it-yourselfers." Customers should not assume this bulletin applies to their vehicle or that their vehicle will develop the described concern. To determine if the information applies, customers should contact their nearest authorized Mazda dealership. Mazda North American Operations reserves the right to alter the specifications and contents of this bulletin without obligation or advance notice. All rights reserved. No part of this bulletin may be reproduced in any form or by any means, electronic or mechanical---including photocopying and recording and the use of any kind of information storage and retrieval system ---without permission in writing.

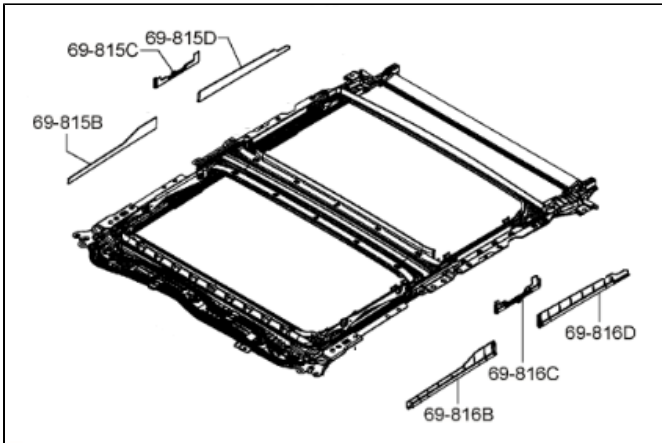

- **YES:** Replace all 6 link covers and retest for the rattle noise.
- **NO:** Skip to the next section.

### PROCEDURE B (FOR CROSS BRACE RATTLE)

The noise comes from the cross brace cover after the vehicle has been driven, and the clips loosen. Follow the instructions below to eliminate the noise.

1) Refer to the video for a test procedure that does not require a test drive.

#### Is there a rattle?

- **YES:** Continue to the next step.
- **NO:** Skip to the next section.

2) Remove the rear glass panel by referring to the instructions in MGSS (SUNROOF REAR GLASS PANEL REMOVAL).

3) Remove the pushpins and then remove the trim.

**CAUTION:** DO NOT damage the trim as it is only available with the sunroof assembly.



**CONSUMER NOTICE:** The information and instructions in this bulletin are intended for use by skilled technicians. Mazda technicians utilize the proper tools/ equipment and take training to correctly and safely maintain Mazda vehicles. These instructions should not be performed by "do-it-yourselfers." Customers should not assume this bulletin applies to their vehicle or that their vehicle will develop the described concern. To determine if the information applies, customers should contact their nearest authorized Mazda dealership. Mazda North American Operations reserves the right to alter the specifications and contents of this bulletin without obligation or advance notice. All rights reserved. No part of this bulletin may be reproduced in any form or by any means, electronic or mechanical---including photocopying and recording and the use of any kind of information storage and retrieval system ---without permission in writing.

4) Add noise reduction material from the **Interior Noise Kit (see below)** anywhere the trim makes contact with the frame.



5) Reassemble the trim in reverse order.

**NOTE:** Make sure the clips are ok and properly reinserted.

6) Reinstall the rear glass by referring to the instructions in MGSS (SUNROOF REAR GLASS PANEL REMOVAL).

7) Retest for the noise.

8) Test drive the vehicle.

**Do any rattling noises remain from the sunroof area?**

- **YES:** Continue to the next section.
- **NO:** Return the vehicle to the customer.

#### **PROCEDURE C (FOR SUNROOF ASSEMBLY RATTLES)**

1) Remove the headliner using the relevant steps from the PANORAMA SUNROOF UNIT REMOVAL procedure.

2) Check the sunroof assembly date by inspecting the label marked in green in the image below; the date is written in MM/DD/YYYY format.

**CONSUMER NOTICE:** The information and instructions in this bulletin are intended for use by skilled technicians. Mazda technicians utilize the proper tools/ equipment and take training to correctly and safely maintain Mazda vehicles. These instructions should not be performed by "do-it-yourselfers." Customers should not assume this bulletin applies to their vehicle or that their vehicle will develop the described concern. To determine if the information applies, customers should contact their nearest authorized Mazda dealership. Mazda North American Operations reserves the right to alter the specifications and contents of this bulletin without obligation or advance notice. All rights reserved. No part of this bulletin may be reproduced in any form or by any means, electronic or mechanical---including photocopying and recording and the use of any kind of information storage and retrieval system ---without permission in writing.

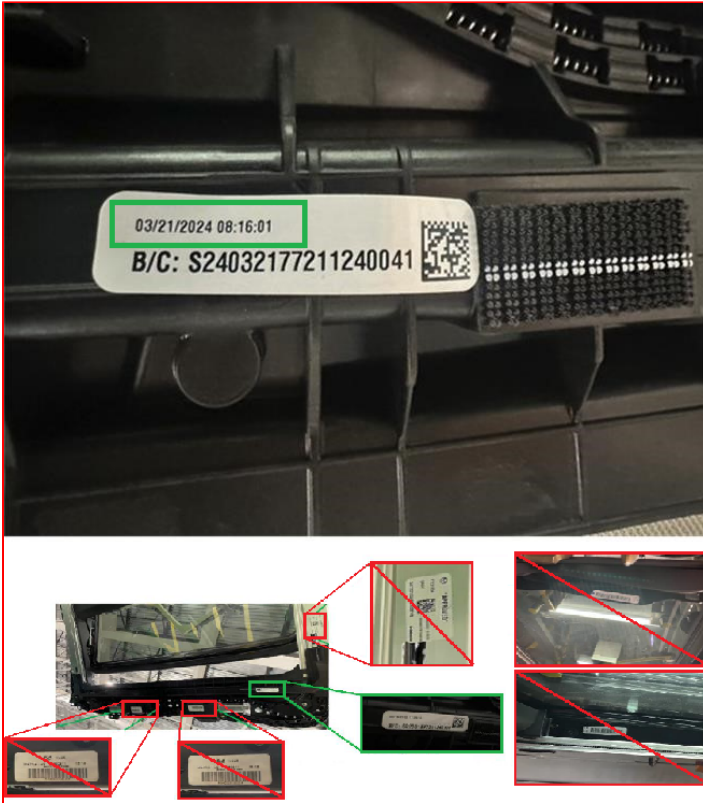

#### Was the sunroof produced before 12/07/2022?

- **YES:** Replace the sunroof unit using the instructions in MGSS (PANORAMA SUNROOF UNIT REMOVAL and PANORAMA SUNROOF UNIT INSTALLATION).
- **NO:** Continue to the next section to check the sunroof mounting.

#### SUNROOF UNIT MOUNTING HARDWARE

- 1) Access the sunroof assembly mounting points using the relevant steps from the PANORAMA SUNROOF UNIT REMOVAL procedure.
- 2) Check the attaching hardware and ensure all nuts and bolts are tightened to specification. Refer to the PANORAMA SUNROOF UNIT INSTALLATION procedure for torque specs, the location of the hardware, and the relevant final assembly steps.

#### Were all the sunroof rattle noises resolved?

- **YES:** Return the vehicle to the customer.
- **NO:** Continue to the next section.

#### SUNROOF UNIT

- 1) Remove the side cover at the front of the assembly to eliminate it as a possible noise source and for better access to the sunroof linkage.
- 2) Drive the vehicle with the sunroof open and confirm if a rattle is coming from the linkage in the general areas the red arrows point to.

**CONSUMER NOTICE:** The information and instructions in this bulletin are intended for use by skilled technicians. Mazda technicians utilize the proper tools/ equipment and take training to correctly and safely maintain Mazda vehicles. These instructions should not be performed by "do-it-yourselfers." Customers should not assume this bulletin applies to their vehicle or that their vehicle will develop the described concern. To determine if the information applies, customers should contact their nearest authorized Mazda dealership. Mazda North American Operations reserves the right to alter the specifications and contents of this bulletin without obligation or advance notice. All rights reserved. No part of this bulletin may be reproduced in any form or by any means, electronic or mechanical--including photocopying and recording and the use of any kind of information storage and retrieval system ---without permission in writing.

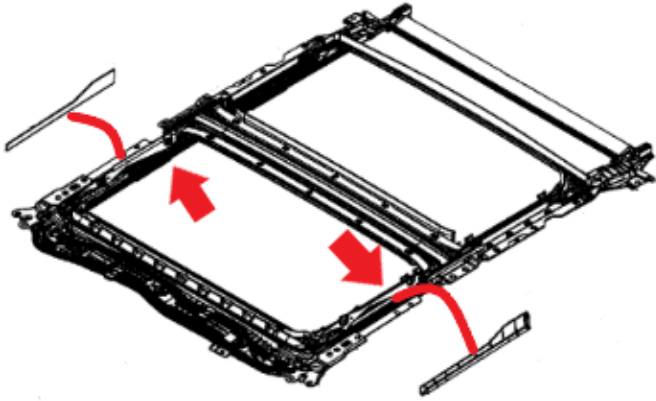

**NOTE:** If you can reach the links that are rattling, you can hold them to confirm if the noise is eliminated.

**Is there a noise from the linkage in this area?**

- **YES:** Replace the sunroof unit.
- **NO:** Create a video of the concern and then contact the Mazda Technical Assistance Hotline.

3. Verify the repair.

#### PARTS INFORMATION

**NOTE:** If replacing any existing parts, use the GEPC with the VIN to look up parts to ensure they are the latest version and correct for that VIN.

Part Number	Description	Qty.	Notes
K001-W0-225	Int. Noise Repair Kit	1	K001-W0-225 is considered a "shop supply/ bundled" into the labor operation time since the kit repairs multiple vehicles.
VA45-69-830 75	Unit ,Sunroof	1	This does not include glass.

#### For Procedure A

Part Number	Description	Qty.	Notes
VAY1-68-2A3	Felt	1	VAY1-68-2A3 is considered a "shop supply/ bundled" into the labor operation time since the kit repairs multiple vehicles.
VA45-69-815	Link Cover (R), Front	1	Only replace if directed by procedure A. VAY1-68-2A3 may still be required with any
VA57-69-815	Link Cover (R), Rear	1	

**CONSUMER NOTICE:** The information and instructions in this bulletin are intended for use by skilled technicians. Mazda technicians utilize the proper tools/ equipment and take training to correctly and safely maintain Mazda vehicles. These instructions should not be performed by "do-it-yourselfers." Customers should not assume this bulletin applies to their vehicle or that their vehicle will develop the described concern. To determine if the information applies, customers should contact their nearest authorized Mazda dealership. Mazda North American Operations reserves the right to alter the specifications and contents of this bulletin without obligation or advance notice. All rights reserved. No part of this bulletin may be reproduced in any form or by any means, electronic or mechanical--including photocopying and recording and the use of any kind of information storage and retrieval system ---without permission in writing.

VA62-69-815	Link Cover (R), Rear	1	replacement covers. If a sheet is not available in the shop, order a sheet for shop supplies when ordering a link cover.
VA57-69-816	Link Cover (L), Rear	1	
VA45-69-816	Link Cover (L), Front	1	
VA62-69-816	Link Cover (L), Rear	1	

**CONSUMER NOTICE:** The information and instructions in this bulletin are intended for use by skilled technicians. Mazda technicians utilize the proper tools/ equipment and take training to correctly and safely maintain Mazda vehicles. These instructions should not be performed by "do-it-yourselfers." Customers should not assume this bulletin applies to their vehicle or that their vehicle will develop the described concern. To determine if the information applies, customers should contact their nearest authorized Mazda dealership. Mazda North American Operations reserves the right to alter the specifications and contents of this bulletin without obligation or advance notice. All rights reserved. No part of this bulletin may be reproduced in any form or by any means, electronic or mechanical---including photocopying and recording and the use of any kind of information storage and retrieval system ---without permission in writing.

**WARRANTY INFORMATION****NOTE:**

- This warranty information applies only to verified customer complaints on vehicles eligible for warranty repair.
- This repair will be covered under Mazda's New Vehicle Limited Warranty term.
- Additional diagnostic time cannot be claimed for this repair.

Warranty Type	A
Symptom Code	82
Damage Code	97
Part Number Main Cause	7777-SP-Y87
Quantity	0
<p>Operation Number / Labor Hours: Claim the Operation No. &amp; Labor Hours for only the completed repair procedures. <b>NOTE:</b> Multiple operation numbers in one claim are acceptable.</p>	<ul style="list-style-type: none"> <li>• XXWYXXRX / 1.8 Hrs. (Procedure A: Link cover replacement)</li> <li>• XXWYYXRX / 1.1 Hrs (Procedure B: Noise reduction material application to the cross braces)</li> <li>• XXWZ1XRX / 3.8 Hrs. (Procedure C w/ Sunroof replacement)</li> <li>• XXWZ2XRX / 1.3 Hrs. (Procedure C w/out Sunroof replacement)</li> </ul>

**NOTE:** Claim Link Cover and/or Felt as related parts.

**CONSUMER NOTICE:** The information and instructions in this bulletin are intended for use by skilled technicians. Mazda technicians utilize the proper tools/ equipment and take training to correctly and safely maintain Mazda vehicles. These instructions should not be performed by "do-it-yourselfers." Customers should not assume this bulletin applies to their vehicle or that their vehicle will develop the described concern. To determine if the information applies, customers should contact their nearest authorized Mazda dealership. Mazda North American Operations reserves the right to alter the specifications and contents of this bulletin without obligation or advance notice. All rights reserved. No part of this bulletin may be reproduced in any form or by any means, electronic or mechanical--including photocopying and recording and the use of any kind of information storage and retrieval system ---without permission in writing.