

JLRTB02127NAS6

TECHNICAL BULLETIN

05 NOV 2025



© Jaguar Land Rover North America, LLC

NOTE: The information in Technical Bulletins is intended for use by trained, professional Technicians with the knowledge, tools, and equipment required to do the job properly and safely. It informs these Technicians of conditions that may occur on some vehicles, or provides information that could assist in proper vehicle service. The procedures should not be performed by 'do-it-yourselfers'. If you are not a Retailer, do not assume that a condition described affects your vehicle. Contact an authorized Land Rover service facility to determine whether this bulletin applies to a specific vehicle.

INFORMATION

This bulletin supersedes TSB JLRTB02127NAS5/2025 dated 28 MAR 2025, which should either be destroyed or clearly marked to show it is no longer valid (e.g. with a line across the page). Only refer to the electronic version of this Technical Bulletin in TOPIx.

Changes are highlighted in blue

SECTION:

303-03A

SUBJECT /CONCERN:

Engine Coolant Level Low with no Visible Loss of Coolant

AFFECTED VEHICLE RANGE:

MODEL:	MODEL YEAR:	VIN:	ASSEMBLY PLANT:
Range Rover (LK)	2022-2024	000001-234058	Solihull

MODEL:	MODEL YEAR:	VIN:	ASSEMBLY PLANT:
Range Rover Sport (L1)	2023-2024	000001-400762	Solihull

MARKETS:

NORTH AMERICA

CONDITION SUMMARY:

SITUATION:

A customer may express a concern that there is a 'Coolant Level Low' message displayed on the instrument panel cluster and the coolant level low or close to minimum, or that the coolant level requires frequently topping up.

This bulletin has been updated to align the Service Repair Operation (SRO)s with the JLRTB02127 Workflow.

CAUSE:

Permeation of water content from the engine coolant through plastic pipes.

ACTION:

Follow the Service Instruction below.



The following applies to:

All Vehicles

PARTS:

NOTES:

- *When stock of 104123458 is depleted order 104123633.
- **An allowance equivalent to £5.00 Sterling has been allocated to locally source engine coolant.

PART NUMBER	DESCRIPTION	QUANTITY
*104123458 or 104123633	Coolant Expansion Tank	1
**ZZZ001	Engine Coolant	£5



The following applies to:

INGENIUM I6 3.0L Petrol / INGENIUM I6 3.0L Petrol PHEV Vehicles Only

PARTS:

NOTES:

- *When stock of 202123501 is depleted order 202123527.
- **The 4 undershield fixing retainers (LR165498) are required for the Plug-in Hybrid Electric Vehicle (PHEV) vehicles **only**.

PART NUMBER	DESCRIPTION	QUANTITY
*202123501 or 202123527	Fuel Supply Line	1
202123508	Fuel Supply Line to Expansion Tank Clip	1
LR185830	Fuel Supply Line to Vapour Damper Bracket Clip	1
**LR165498	Undershield Fixing Retainer	4

TOOLS:



E381854

JLR-1839

Cooling system pressure tester



E332634

JLR-303-1720-02

Coolant System Pressure Tester Cap and Adapter

WARRANTY:

△ NOTES:

- Repair procedures are under constant review, and therefore times are subject to change; those quoted here must be taken as guidance only. Use TOPIx to obtain the latest repair time.
- The JLR claims submission system requires the use of causal part numbers. Labor only claims must show the causal part number with a quantity of zero.

DESCRIPTION	SRO	TIME (HOURS)	CONDITION CODE	CAUSAL PART
JLRTB - Coolant Level Low - INGENIUM I6 3L Diesel / V8 T/C 4.4L Petrol	99.04.11	0.8	*	LR151660
JLRTB - Coolant Level Low + Fuel Supply Line - INGENIUM I6 3L Petrol	99.04.11.01	3.8	*	LR178362
JLRTB - Coolant Level Low + Fuel Supply Line - INGENIUM I6 3L Petrol - PHEV	99.04.11.01	4.0	*	LR178362

 **NOTE:**

Normal Warranty procedures apply.

COOLING SYSTEM PRESSURE TEST

 **WARNING:**

Injury such as scalding could be caused by escaping steam or coolant. The vehicle cooling system must be cool prior to completing this procedure.

 **CAUTIONS:**

- Engine coolant can damage the paint finished surfaces. If spilt, immediately remove the fluid and clean the area with water.
- Never remove the coolant expansion tank filler cap under any circumstances while the engine is operating. Failure to follow this instruction may result in damage to the engine.
- Mating faces must be are clean and free of foreign material.

 **NOTES:**

- This procedure contains some variation in the illustrations depending on the vehicle specification, but the essential information is always correct.

- This procedure contains illustrations showing certain components removed to provide extra clarity.

1.

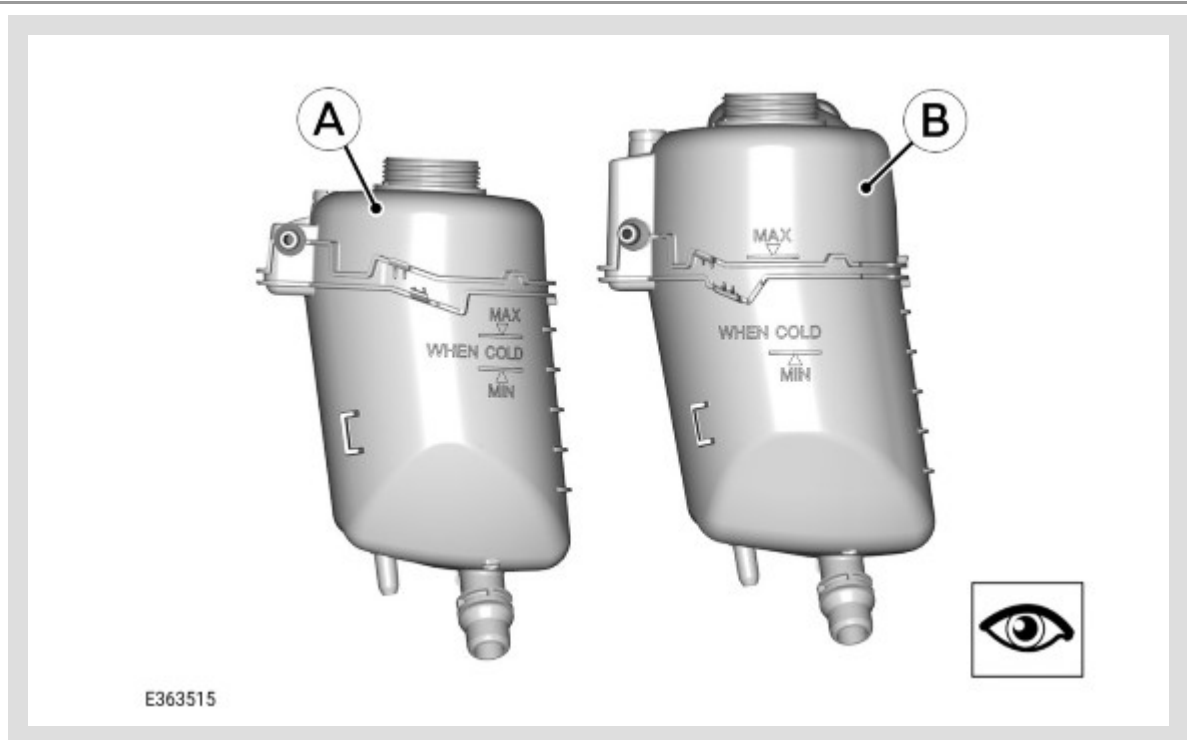

Inspect the coolant expansion tank.

- If coolant expansion tank 'B' is installed **do not** continue with this bulletin. Repair as necessary with reference to TOPIx.
- If coolant expansion tank 'A' is installed continue to the next step.

2. Inspect the coolant level in the coolant expansion tank. If the coolant is at the maximum level in the coolant expansion tank and the 'Coolant Level Low' message is displayed on the instrument panel cluster **do not** continue with this bulletin. Repair as necessary with reference to TOPIx.

 **NOTE:**

Any related repairs must be claimed as a separate warranty claim.

Visually check the cooling system for signs of engine coolant leaks and distorted hoses. Make sure all the cooling system components are correctly installed.

- If there **are** any visual signs of engine coolant leaks **do not** continue with this bulletin. Repair as necessary with reference to TOPIx.
- If there **are no** visual signs of engine coolant leaks continue to the next step.

 **NOTE:**

The following procedure will enable the cooling system to be pressure tested for condition and leaks. Step 4 will check the expansion tank filler cap seal and the filler cap for leaks. Step 6 will check the entire cooling system.

⚠ WARNING:

Release the cooling system pressure by slowly turning the coolant expansion tank cap a quarter of a turn. Cover the expansion tank cap with a thick cloth to prevent the possibility of scalding. Failure to follow this instruction may result in personal injury.

ⓘ CAUTION:

Be prepared to collect escaping coolant.

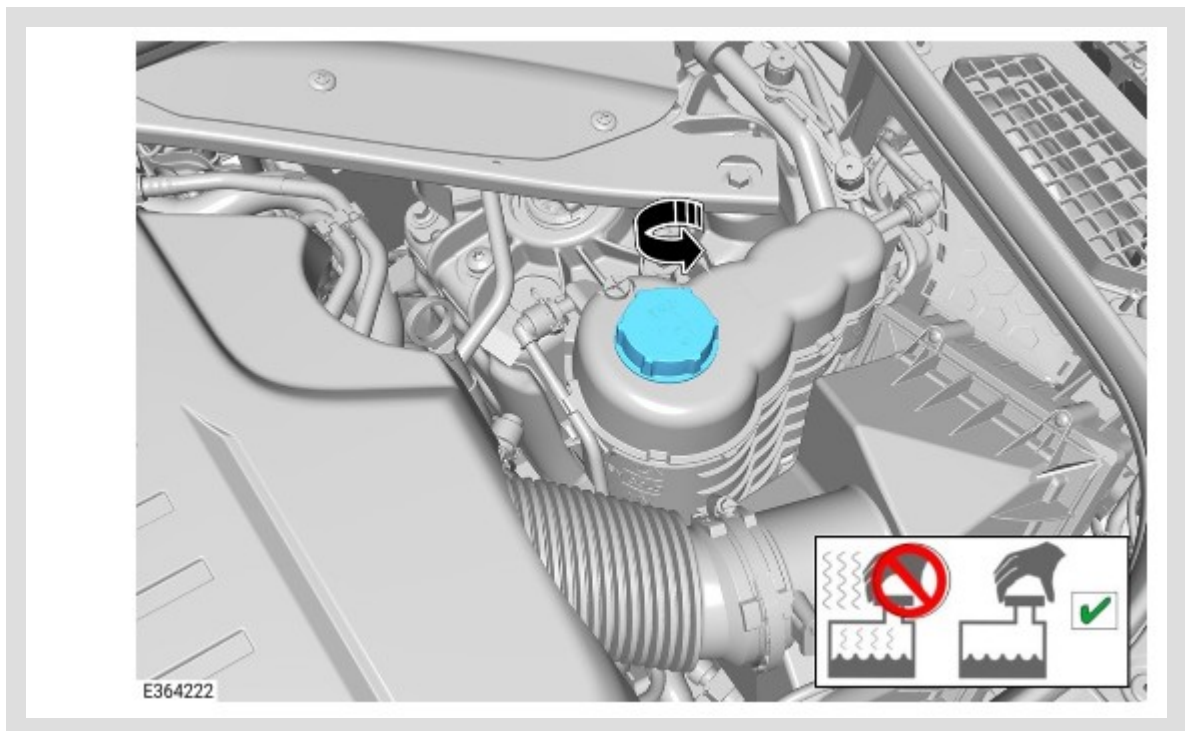

Remove the coolant expansion tank filler cap.

⚠ WARNING:

Do not pressurize the coolant expansion tank filler cap to the maximum pressure shown on the filler cap.

△ NOTE:

Any related repairs must be claimed as a separate warranty claim.

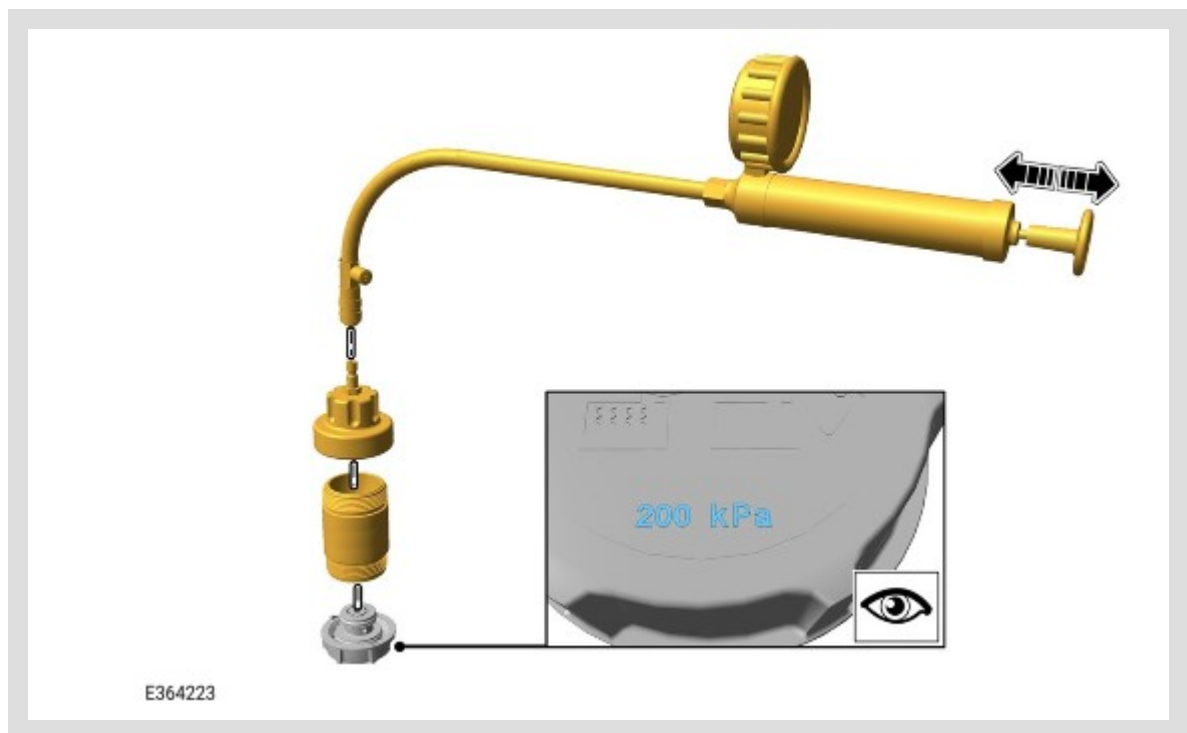

Using the correct adapter connect the cooling system pressure tester to the coolant expansion tank filler cap.

- Slowly pressurize the coolant expansion tank filler cap 1.6 bar (23 psi) as shown on the gauge. No significant drop in pressure must be noted on the coolant expansion tank filler cap. If after 5 minutes the pressure significantly drops, the coolant expansion tank filler cap must be replaced.
- If 1.6 bar (23 psi) is reached with no drop in pressure, validate the coolant expansion tank filler cap by increasing the pressure to between 1.7 bar (25 psi) to 2.1 bar (30 psi) to confirm the valve is operating as intended. The pressure must be released through the coolant expansion tank filler cap.
- If the coolant expansion tank filler cap fails this test, the coolant expansion tank cap must be replaced. This must be completed under related repairs and must be claimed as a separate warranty claim.

6. Depressurize and remove the coolant expansion filler tank cap from the cooling system pressure tester.

- Disassemble the cooling system pressure tester.

7.

⚠ CAUTION:

Do not exceed 2.0 bar (28 psi) when pressurizing the cooling system.

△ NOTE:

If the pressure continues to drop after the initial tolerance, the cooling system must to be checked for leaks.

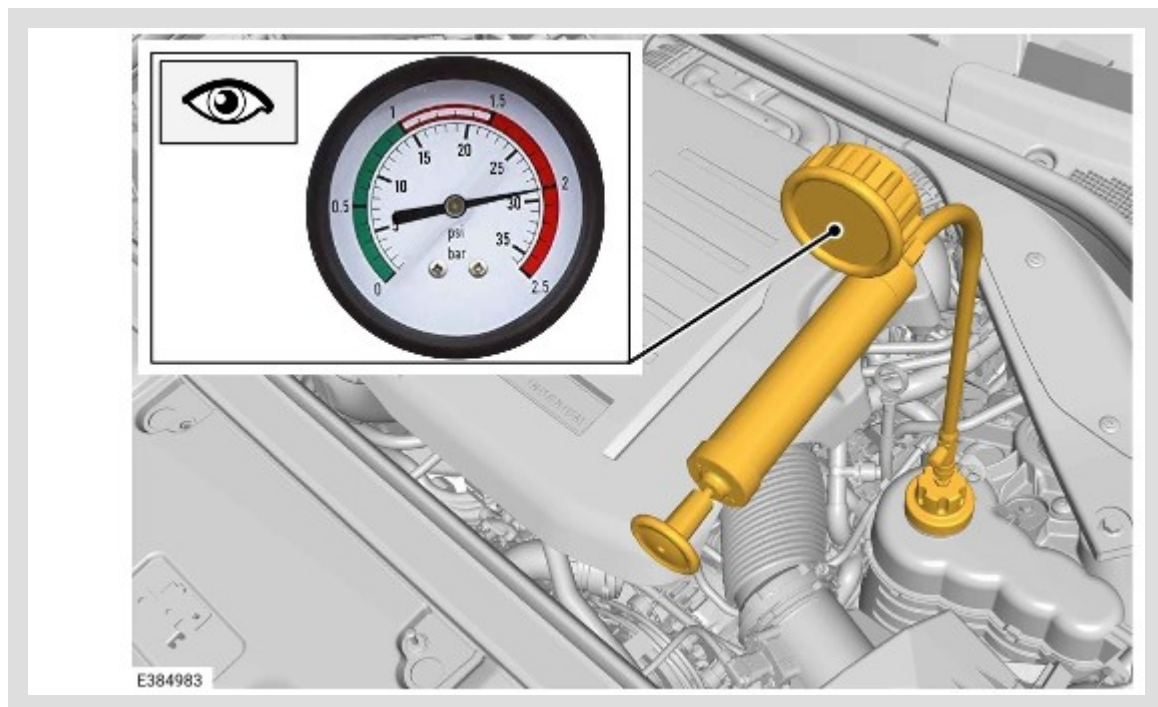

Using the correct adapter connect the cooling system pressure tester to the coolant expansion tank.

- Slowly pressurize the cooling system until 2.0 bar (28 psi) is shown on the gauge.
- No significant drop in pressure must be noted on the cooling pressure tester gauge. If after 5 minutes the pressure significantly drops, inspect the cooling system for leaks. A pressure drop of 0.15 bar (1psi) in the first minute is considered normal operation.

8.

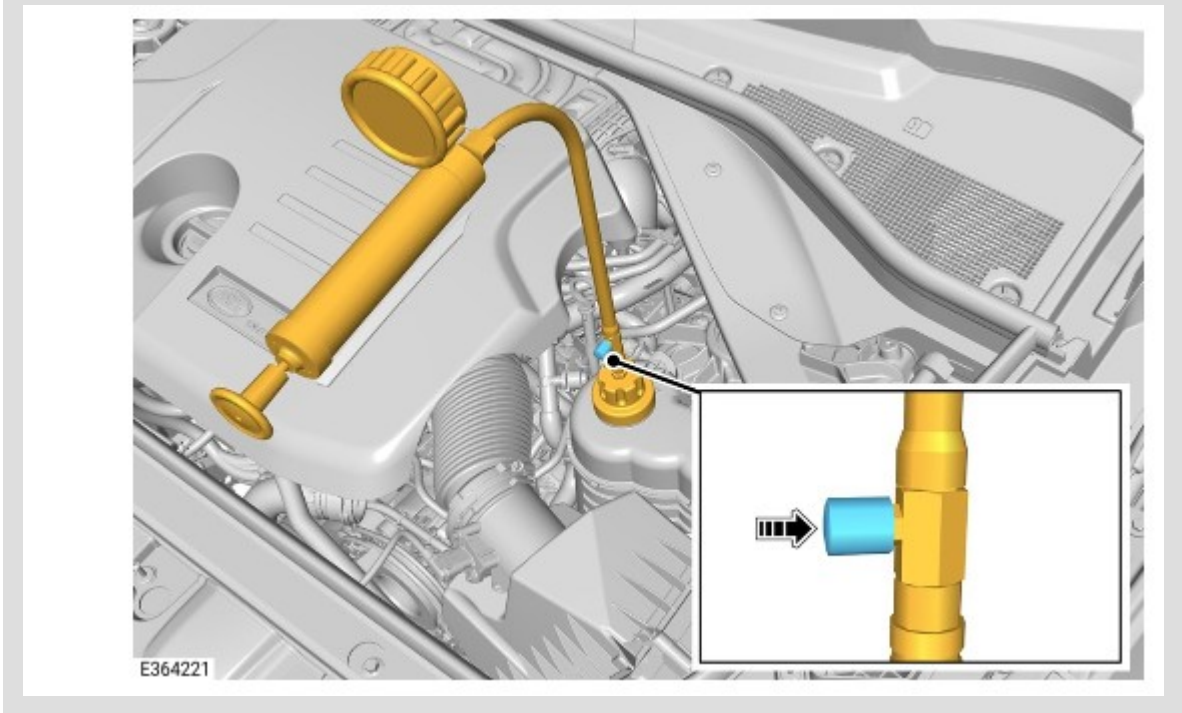

Depressurize and remove the cooling system pressure tester.

9. Install the coolant expansion tank filler cap.

10.

NOTE:

Any related repairs must be claimed as a separate warranty claim.

Visually check the cooling system for signs of engine coolant leaks.

- If there **are** any visual signs of engine coolant leaks **do not** continue with this bulletin. Repair as necessary with reference to TOPIx.
- If there **are no** visual signs of engine coolant leaks complete the **SERVICE INSTRUCTION** section of this bulletin.

SERVICE INSTRUCTION:

INGENIUM I6 3.0L Petrol, INGENIUM I6 3.0L Petrol PHEV Vehicles Only:

1. Remove the fuel supply line (see TOPIx Workshop Manual section 310-01: Fuel Tank and Lines - Removal and Installation - Fuel Supply Line).

All Vehicles:

-
2. Renew the coolant expansion tank (see TOPIx Workshop Manual section 303-03: Engine Cooling - Removal and Installation - Coolant Expansion Tank).

INGENIUM I6 3.0L Petrol, INGENIUM I6 3.0L Petrol PHEV Vehicles Only:

3. Install the new fuel supply line (see TOPIx Workshop Manual section 310-01: Fuel Tank and Lines - Removal and Installation - Fuel Supply Line).

All Vehicles:

4. Check the coolant concentration (see TOPIx Workshop Manual section 303-03: Engine Cooling - General Procedure - Cooling System Concentration Check).