



Service Bulletin

Bulletin No.: PIT6132D

Date: November, 2025

PRELIMINARY INFORMATION

Subject: Hum Buzz Vibration Type Noise From HVAC When Set To Defrost Or Floor Positions

Brand:	Model:	Model Year:		VIN:		Engine:	Transmission:
		from	to	from	to		
Cadillac	Escalade	2021 - 2026		All	All	All	All
Cadillac	Escalade ESV	2021 - 2026		All	All	All	All
Chevrolet	Silverado 1500	2021 - 2026		All	All	All	All
Chevrolet	Silverado 2500	2021 - 2026		All	All	All	All
Chevrolet	Silverado 3500	2021 - 2026		All	All	All	All
Chevrolet	Suburban	2021 - 2026		All	All	All	All
Chevrolet	Tahoe	2021 - 2026		All	All	All	All
GMC	Sierra 1500	2021 - 2026		All	All	All	All
GMC	Sierra 2500	2021 - 2026		All	All	All	All
GMC	Sierra 3500	2021 - 2026		All	All	All	All
GMC	Yukon	2021 - 2026		All	All	All	All
GMC	Yukon XL	2021 - 2026		All	All	All	All

Involved Region or Country	North America
Condition	<p>Some customers may comment of a hum, buzz, or vibration type noise coming from the HVAC when the mode is set to the defrost or floor positions along with higher blower speeds and higher temperature settings. If the HVAC mode is changed to include the instrument panel dash vents the noise will be gone.</p> <p>Note: Replacing the HVAC case will not correct this condition and if the HVAC case is replaced the new case will need the repair shown below to resolve the noise.</p>
Cause	<p>The cause of this concern could be the HVAC instrument panel dash vent door seals (2) vibrating against the HVAC case, shown below. This concern only happens when the HVAC instrument panel dash vent doors (2) are in the closed position along with the HVAC set to a higher temperature and blower speed.</p>

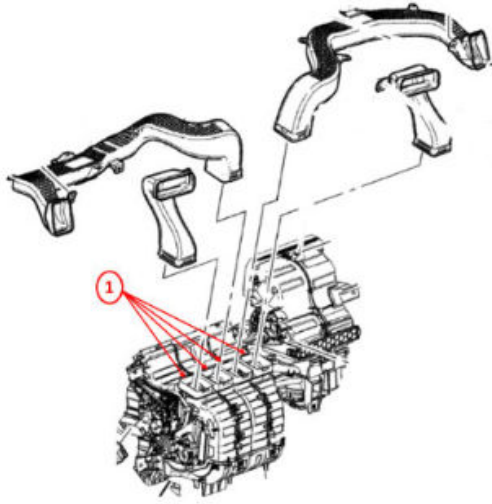

6727886

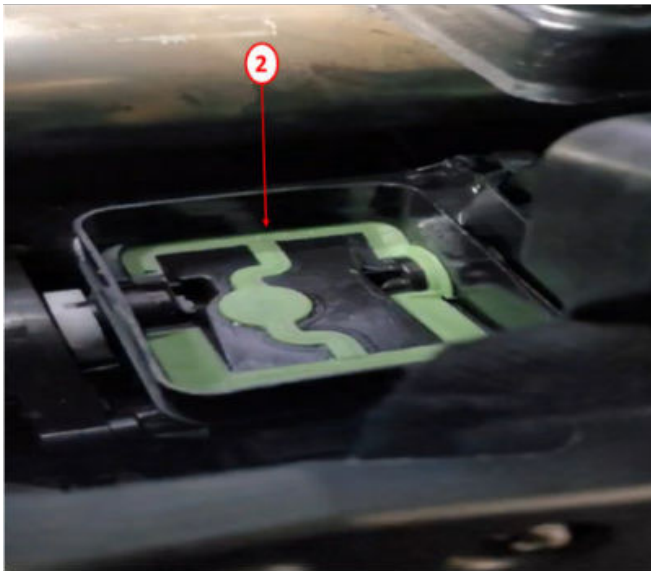

6727888

Correction

Apply flocking tape (3) to the forward edge of each HVAC instrument panel dash vent duct openings (1) at the door sealing surface (4) where the forward edge of the door contacts the HVAC case.

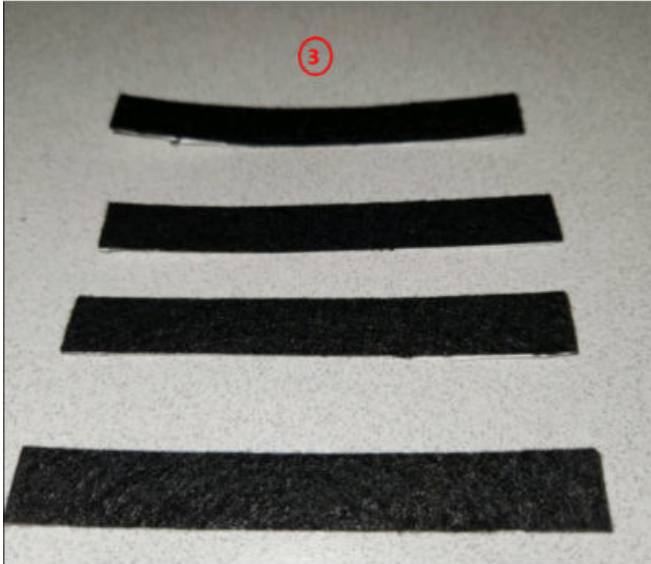

6727889

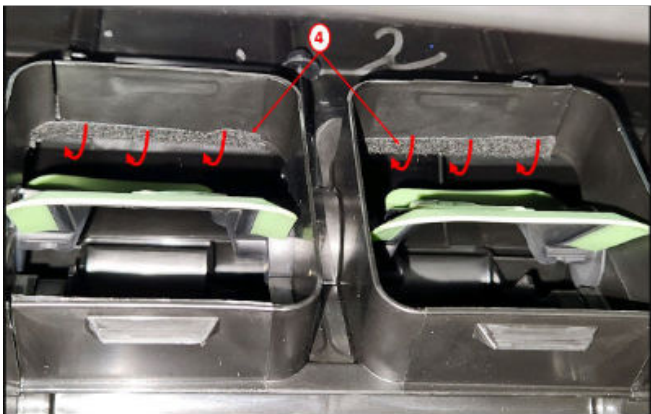

7012570

- Before any disassembly use the HVAC controls to set the mode to the full instrument panel dash vent position, this will open the instrument panel dash vent doors to allow the installation of the flocking tape.

Important: Do not attempt to remove the bracket from the bottom of the passenger's airbag. This bracket has non-serviceable fasteners. Attempting to remove them will damage the passenger's side airbag module. To enable removal of the I/P trim with the airbag module, it may help to remove some fasteners from the I/P structure to allow the right side of the structure to be moved out of the way. This will allow the passenger's airbag and I/P trim to be removed more easily.

- Next, access the left and right instrument panel outer and center air outlet ducts, which in most cases can be done by following SI procedure for "Instrument Panel Upper Trim Panel Removal and Installation".
- When applying the flocking tape, it should be cut to fit the duct opening and in most cases about 15mm will need to be trimmed off the end of each strip before it is installed.

- The tape should be applied to the forward edge of the port with about half of the tape width positioned in the door sealing/contact area and then wrap the remaining tape width up into the port opening, as shown (4). Use an alcohol wipe to clean the HVAC case where the flocking tape will be applied. Apply the flocking tape to the case and use firm pressure to make sure the tape fully adheres to the HVAC case.
- Apply the flocking tape to all 4 instrument panel air outlet duct openings.
- Reassemble the vehicle.

Parts Information

The flocking tape can be obtained from the Warranty Parts Center (WPC) using the TSP Dealer Request Form

This form is located on: Global Connect<Service Department<Service Forms Application<General Information tab<TSP Dealer Request Form.

Instructions for submitting are on the form.

Request WPC886.

Tape will come from the WPC in a card with four strips and enough to repair one vehicle.

Warranty Information

For vehicles under warranty, use the following unique labor operation below.

Labor Operation	Description	Labor Time
4486238*	Remove I/P top cover and IP dash vents to allow damping tape to applied to the HVAC module ports for the dash vents	3.5 Hrs.
* This is a unique labor operation for bulletin use only.		

Version	5
Modified	03/12/2024 - Created on. 08/30/2024 - Updates to the Condition, Cause, Correction, Warranty and Parts sections. 02/11/2025 - Updates to the correction section. 10/22/2025 - Updates to the model list, condition and last picture in correction. 11/26/2025 - Updated model list to add 2026

