

Technical Information

FROM: Maserati TSO
TO: Maserati Network



PERSONAL SERVICE LAB

MASTERS OF CARE

Grecale / GranTurismo / GranCabrio – Availability of Steering Wheel Buttons



DATE: NOVEMBER 19, 2025

This bulletin provides updated guidance on the serviceability of the multifunction control buttons integrated into the steering wheel of certain Maserati vehicles.

For repairs or replacements, the button assembly can now be serviced independently, without replacing the entire steering wheel. These buttons are available as individual sub-components, enabling targeted replacement.

MODELS AFFECTED: M182 Grecale, M189 GranTurismo, and M190 GranCabrio (All MY).

Available Components Details

The following part numbers are currently available for the replacement of steering wheel controls:

P/N	DESCRIPTION	P/N	DESCRIPTION
670269846	LH Controls (17)	670275676	START Button (15)
670274797	LH Controls (17)	670269851	START Button (15)
670269849	RH Controls (18)	670269861	Drive Mode Selector (16)
670269847	RH Controls (18)	670269850	Drive Mode Selector (16)
670269848	RH Controls (18)		

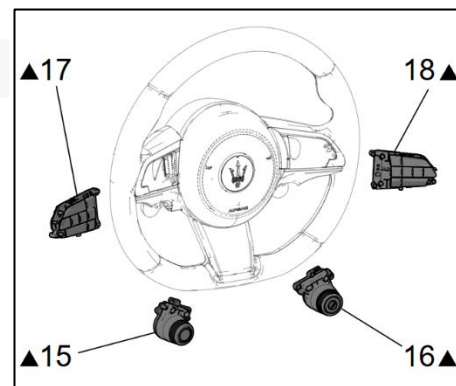

Note: Always refer to the updated Technical Documentation (TechDocs) to confirm correct part application.

Workshop Procedures

Replacement procedures are published in the Technical Documentation (TechDocs):

- #5.00.094.0: LH Steering Wheel Switch Pack (Removal-Refit or Replacement).
- #5.00.093.0: RH Steering Wheel Switch Pack (Removal-Refit or Replacement).
- #5.00.092.0: START Button (Removal-Refit or Replacement).
- #5.00.091.0: Drive Mode Selector (Removal-Refit or Replacement).

Special Tools: Not required.

We remain at your disposal for any further clarification.

Best regards.

TECHNICAL SERVICE OPERATIONS