

- ATTENTION:**
- GENERAL MANAGER
 - PARTS MANAGER
 - CLAIMS PERSONNEL
 - SERVICE MANAGER

IMPORTANT - All Service Personnel Should Read and Initial in the boxes provided, right.

| | | | | | |
|--|--|--|--|--|--|
| | | | | | |
| | | | | | |

© 2025 Subaru of America, Inc. All rights reserved.



QUALITY DRIVEN® SERVICE

SERVICE INFORMATION BULLETIN

APPLICABILITY: 2025-26MY Forester
2025-26MY Forester Hybrid

NUMBER: 12-274-25
DATE: 11/06/25

SUBJECT: Rear Bumper / Replacement Procedure

INTRODUCTION:

This Service Information Bulletin announces changes to the replacement procedure due to a design difference between Japan-produced bumpers and SIA-produced bumpers. Japan-built Forester models (first three VIN digits: JF2) feature through-holes for the rubber hatch stops, allowing the rubber stops to contact the vehicle body. In contrast, SIA-built Forester models (first three VIN digits: 4S4) have blind holes, causing the rubber hatch stops to contact the bumper itself, which requires a differently shaped hatch stop. If you are replacing the rear bumper on a Japan-built Forester, please follow the procedure outlined below, as the new replacement part will be SIA-made.

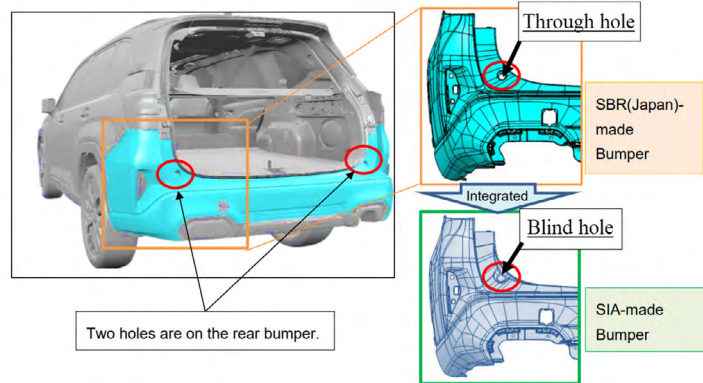

PART INFORMATION:

REMINDER: Always order the most up-to-date replacement parts based on the specific VIN being repaired.

| New Part Number | Part Description |
|-----------------|-------------------------|
| 57704SL80A | BUMPER FACE,REAR |
| 57702SL80A | BUMPER FACE,REAR |
| 63259SL000 | STOPPER-REAR GATE(Both) |
| 57253AA031 | PROTECTOR BUFFER |
| 57748SL00A | Protector |

CAUTION: VEHICLE SERVICING PERFORMED BY UNTRAINED PERSONS COULD RESULT IN SERIOUS INJURY TO THOSE PERSONS OR TO OTHERS.

Subaru Service Bulletins are intended for use by professional technicians ONLY. They are written to inform those technicians of conditions that may occur in some vehicles, or to provide information that could assist in the proper servicing of the vehicle. Properly trained technicians have the equipment, tools, safety instructions, and know-how to do the job correctly and safely. If a condition is described, DO NOT assume that this Service Bulletin applies to your vehicle, or that your vehicle will have that condition.

Subaru of America, Inc. is ISO 14001 Compliant

ISO 14001 is the international standard for excellence in Environmental Management Systems. Please recycle or dispose of automotive products in a manner that is friendly to our environment and in accordance with all local, state and federal laws and regulations.

Continued...

SERVICE PROCEDURE / INFORMATION:

REMINDER: Customer satisfaction and retention starts with performing quality repairs.

When installing a new bumper on a **Japan-built Forester** follow these additional steps

Step 1: Remove old tape originally applied and clean all adhesive off the body. Then apply protector (57748SL00A) as seen in the diagram below.

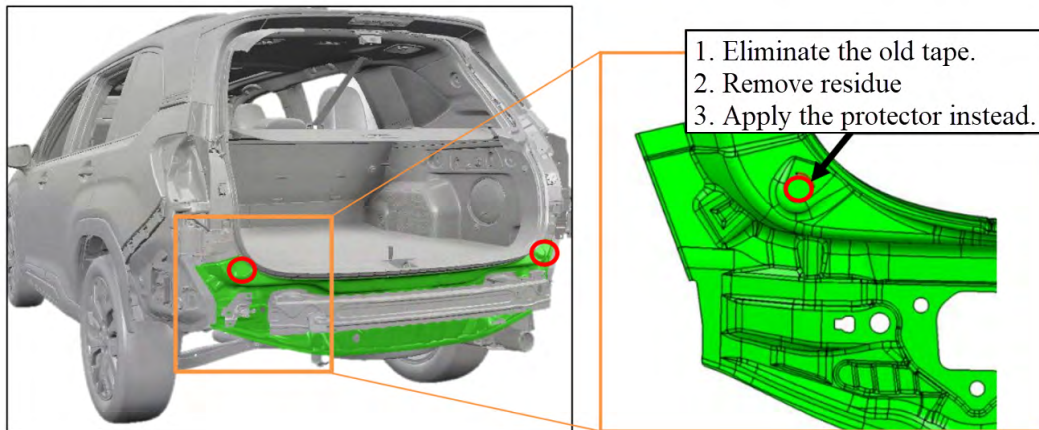

Step 2: Install the rear bumper assembly. Apply Protector Buffer (57253AA031) to the blind holes on both sides, as illustrated.

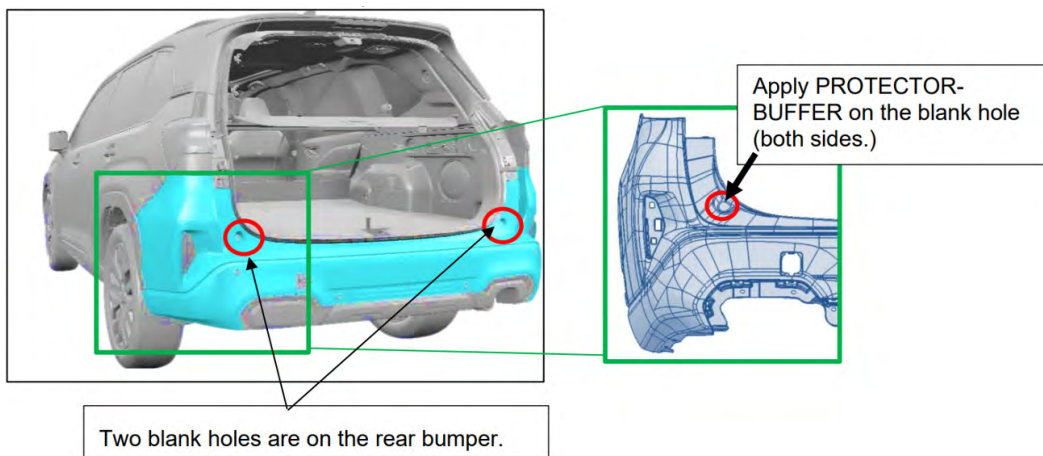

Step 3: Replace both rubber stoppers on the gear gate with 63259SL000.

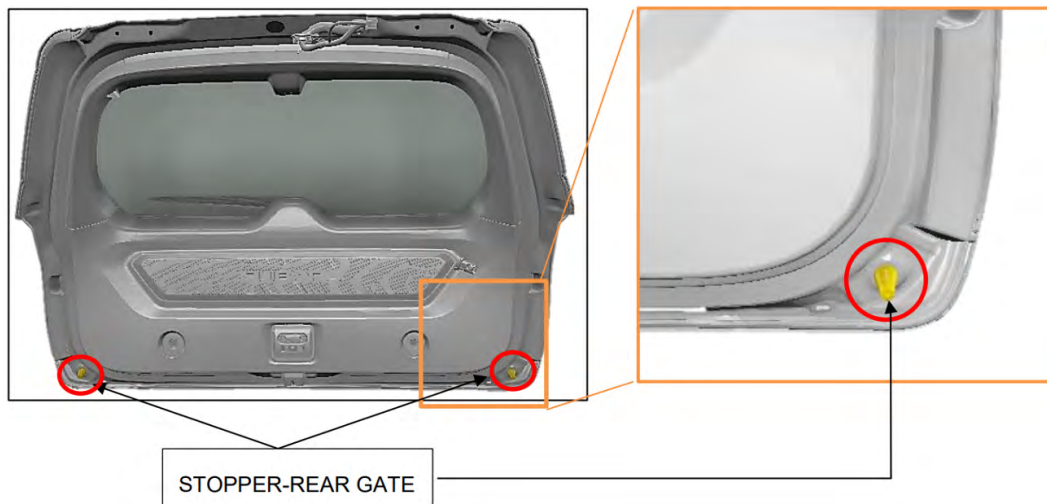

Continued...

IMPORTANT REMINDERS:

- SOA strongly discourages the printing and/or local storage of service information as previously released information and electronic publications may be updated at any time.
- Always check for any open recalls or campaigns anytime a vehicle is in for servicing.
- Always refer to STIS for the latest service information before performing any repairs.