



Technical Service Bulletin

| | |
|-------------------------------------|---|
| GROUP CAMPAIGN | NUMBER 25-01-082G |
| DATE NOVEMBER 2025 | MODEL(S) GV60 (JW1 EV) |

SUBJECT: LED HEADLAMP AIMING INSPECTION & ADJUSTMENT
(SERVICE CAMPAIGN 918G)

* IMPORTANT

Retailers must perform this service campaign on all affected vehicles prior to retail delivery to a guest and whenever an affected vehicle is in the shop for any maintenance or repair.

Access the "Vehicle Information" screen via WebDCS to identify open campaigns.

Description: Certain GV60 (JW1 EV) vehicles may have headlamps that are not optimally adjusted, although the vehicles and headlamps meet required standards and aiming requirements. This bulletin provides instructions for inspecting and performing minor adjustments to the headlamp beams.



Applicable Vehicles:

| Model Year | Model | Production Dates |
|------------|---------------|-------------------------|
| 2026 | GV60 (JW1 EV) | 07/09/2025 – 08/25/2025 |

NOTICE

To avoid any potential damage to Genesis EVs, Genesis EV repairs can only be performed by EV certified Genesis retailers.

SST Information:

| Tool Name | Tool Number | Figure | Ordering Information |
|-----------------------------------|-------------|---|--|
| Centerline Laser | 09964-C1200 |  | Website: https://genesisessentialtools.com/ Email: GenesisTools@snapon.com Phone: 1-855-763-6630 Hours: 7 AM – 7 PM CST |
| Smart Cruise Control (SCC) Tripod | 09964-C1300 |  | |

Required Equipment/Supplies:

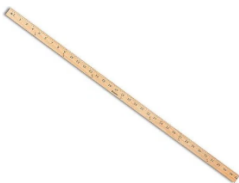
| Name | Equipment/Supply # | Figure | Remarks |
|---|------------------------|--|--|
| Tape Measure | Commercially available |  | |
| Yardstick Ruler | |  | NOT required, but can be useful |
| Blue Painter's Tape, Masking Tape, or Duct Tape | |  | Any tape may be used |
| Permanent Marker | |  | Sharpie (or similar) |
| Tempered Hardboard/Metal Shims, 12" x 12", 1/8" thick | |  | Approx. 20 pieces required |

Warranty Information:

| Model | Op. Code | Operation | Op. Time | Causal Part | Nature Code | Cause Code |
|------------------|----------|---|----------|-------------|-------------|------------|
| GV60 (JW1 EV) | 50D299R0 | Headlamp Aiming Inspection and Adjustment | 0.3 M/H | 92102-CU050 | B31 | ZZ7 |
| | 50D299R1 | Headlamp Aiming Inspection and Adjustment + Workstation Setup | 1.0 M/H | | | |

NOTE 1: Submit claim on Claim Entry Screen as “Campaign” type.

NOTE 2: If a part is found in need of replacement while performing this campaign and the affected part is still under warranty, submit a separate claim using the same repair order. If the affected part is out of warranty, submit a Prior Approval request for goodwill consideration prior to performing the work.

NOTE 3: This TSB includes repair validation photos. Op times include VIN, mileage, and repair validation photo(s) as outlined in the Digital Documentation Policy.

NOTE 4: Please note that op code 50D299R1 for 1.0 M/H is for BOTH setting up the technician station’s area for headlamp aiming and for the service procedure of headlamp aiming. If a new station needs to be setup and headlamp aiming be performed, please claim 1.0 M/H. If station is already setup based on a previous vehicle being repaired, please claim op code 50D299R0 for 0.3 M/H.

Submitted claims where dealers already have the station setup, but are claiming 1.0 for BOTH setup and headlamp aiming, are subject to chargeback.

Service Procedure:

DIGITAL DOCUMENTATION



This TSB includes repair validation photos. Refer to the latest Warranty Digital Documentation Policy for requirements.

NOTICE

Applying the recommended torque to all fasteners is essential to reduce potential issues from occurring after the service procedure.

Table of Contents

- Headlamp Beam Aiming: Workstation Setup.....4
- Headlamp Beam Aiming: Validation/Adjustment8

Headlamp Beam Aiming: Workstation Setup

i Information

- Once the headlamp aiming/adjustment station is set up as described in this procedure it may be used for multiple vehicles.
- Ensure each vehicle's tires are inflated to proper specification prior to performing headlamp aiming/adjustment.

Vehicle Alignment to Wall or Screen:

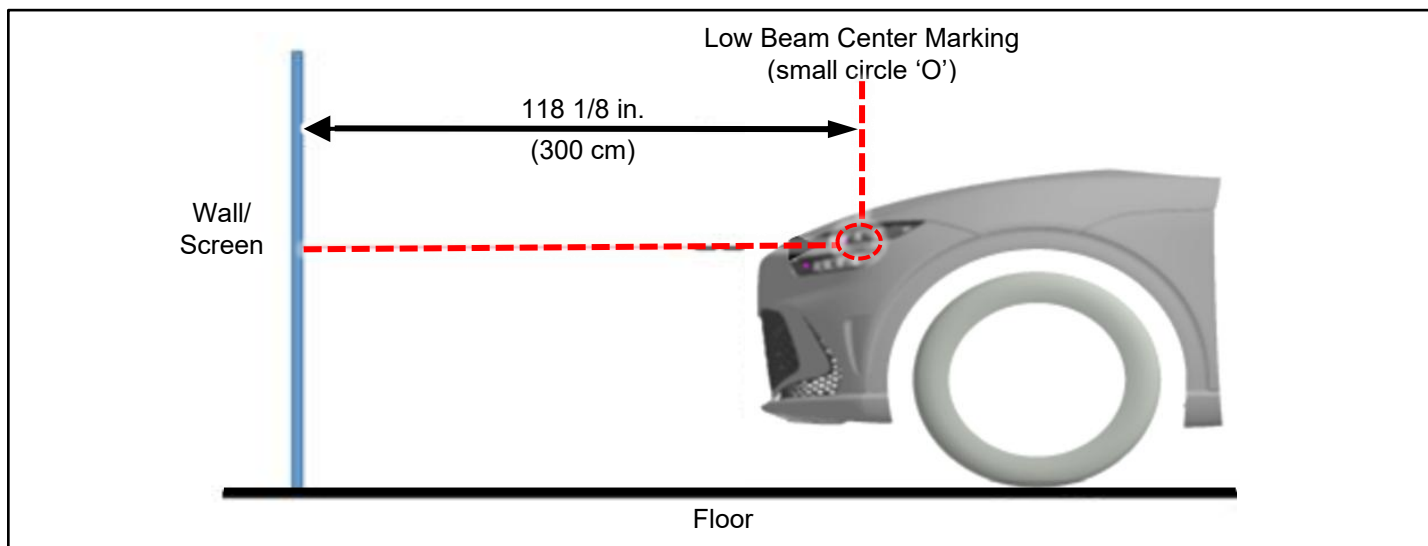

1. Park the vehicle on a flat surface facing a wall or screen.

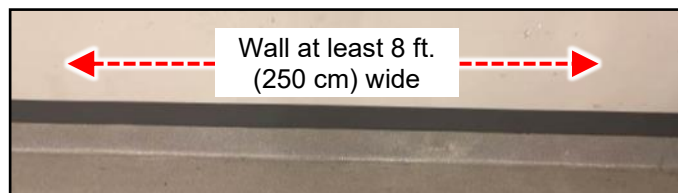

i Information

Park more than **118 1/8 in. (300 cm)** from the wall to allow space to apply tape to the floor in **step 3**.

Ensure wall or screen is wide enough to display both left and right headlamp beams, at least **8 ft (250 cm)** wide.

2. Check the tire pressure of all **4 tires** and confirm they are inflated to the correct specifications, approx. **38 psi**. Adjust as needed.



3. Measure **118 1/8 in. (300 cm)** from the wall and apply **2 pieces** of tape (masking tape, duct tape, or equivalent) onto the floor approximately **42 in. (106 cm)** apart.

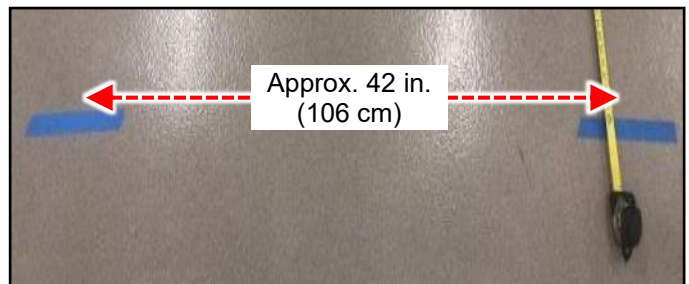
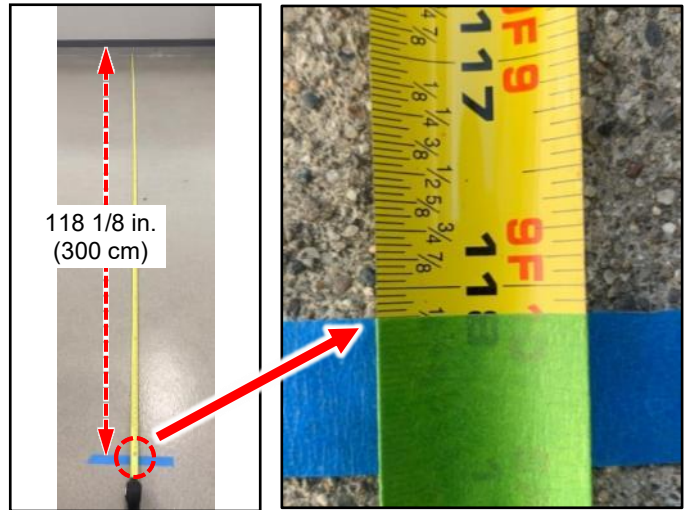

4. Drive the vehicle towards the **2 tape marks** on the floor and measure **118 1/8 in. (300 cm)** from the low beam center marking to the wall/screen.

Confirm **both** the left and right low beam center markings are **118 1/8 in. (300 cm)** away from the wall/screen. This will ensure the vehicle's headlamps are parallel with the wall/screen.

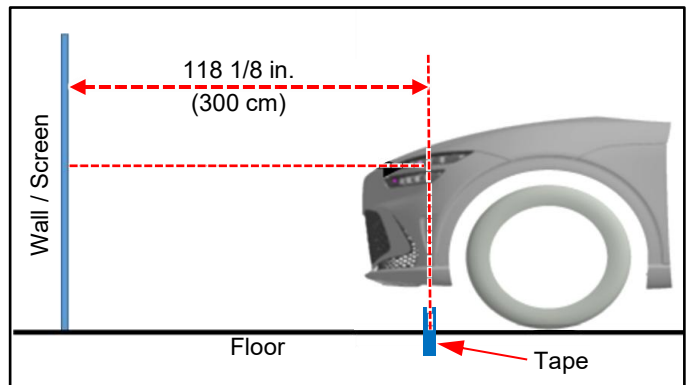

i Information

The low beam center marking is an imprinted circle on the upper part of the headlamp, shown in the photos.

If the marking is difficult to find, it can be easier to see when viewing from different angles.

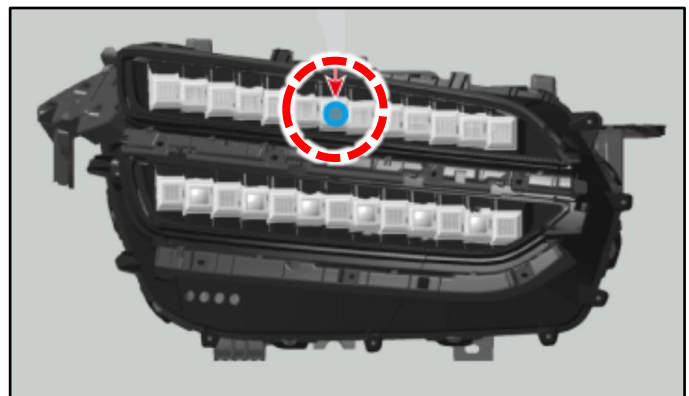
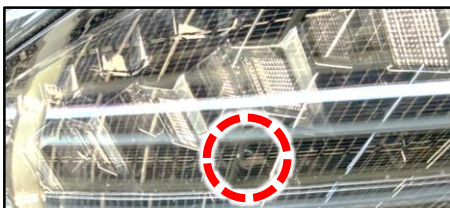

- Apply a piece of tape onto the floor near the center of each tire. Using a Sharpie or similar marker, draw a line on the tape aligning with the center of the wheel as shown.

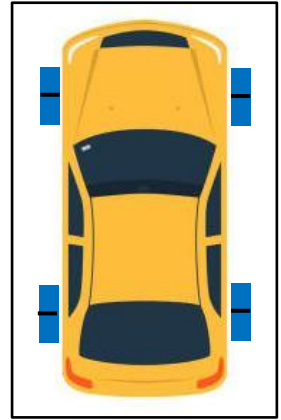

Floor Level Validation:

- Move the vehicle away from the marked tape pieces.
- Connect the laser to the tripod (A) and position it near one of the **4 marked tape pieces (B)** on the floor.
- Turn the laser **ON** and confirm it is projecting a constant horizontal beam. Adjust the tripod tilt if necessary until the laser is projecting a constant beam to all 4 corners.

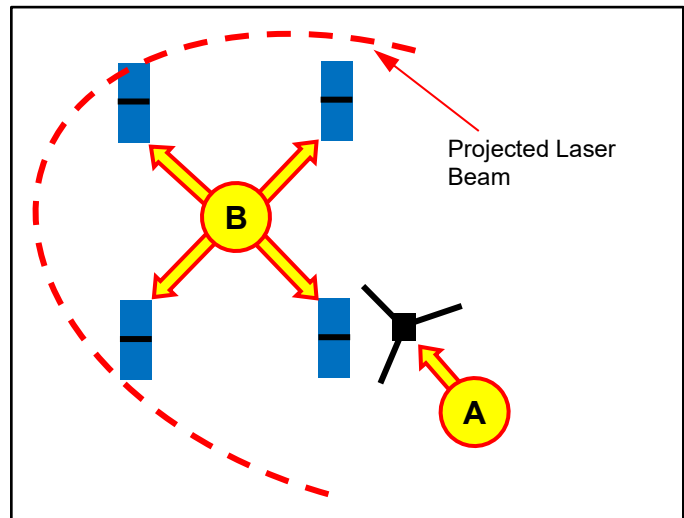

***i* Information**

The laser is a self-leveling system. As long as there is a constant beam, it is projecting a horizontal line.

4. Adjust the laser to any desired height, for example, **32 in. (81 cm)**, and then tighten the tripod legs and laser to ensure the setting does **NOT** change.
5. Take measurements at the remaining **3 tape markings** on the floor.



6. Compare the four height measurements.
 - If all 4 measurements match, then the floor is level. Proceed to [Headlamp Beam Aiming: Validation/Adjustment](#).
 - If the measurements do **NOT** match, then proceed to the next step.
7. A measurement of **32 3/8 in. (82 cm)** indicates this corner (C) has a slight dip in the floor. This corner requires **three (3) 1/8 in.** shims to make it level with the other corners.

Place the required shims on the floor where the tire will sit. Tape the shims down with duct tape to prevent slippage and save the setup for the next vehicle.

i Information

This is **ONLY** an example. There may be cases when multiple corners require shimming.

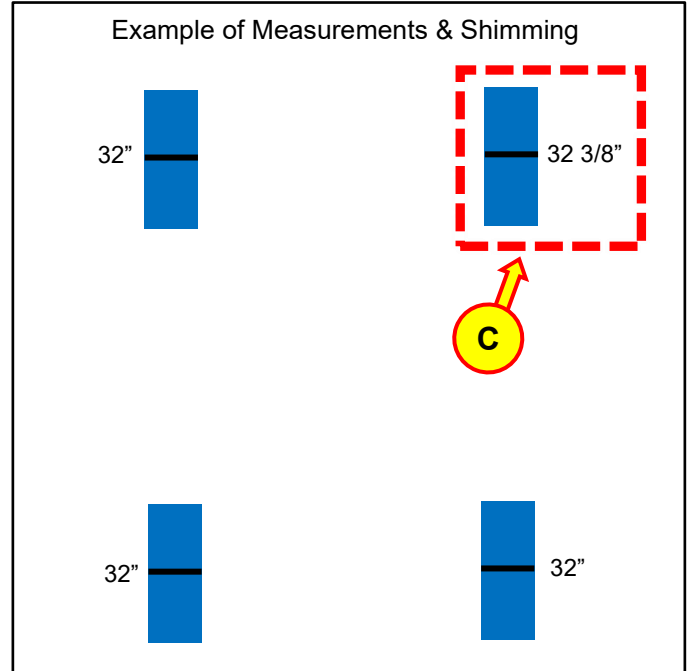

Headlamp Beam Aiming: Validation/Adjustment

***i* Information**

- Before starting this procedure, ensure that the [Headlamp Beam Aiming: Workstation Setup](#) has been completed.
- Ensure each vehicle's tires are inflated to proper specification prior to performing headlamp aiming and adjustment.

1. Drive the vehicle into the area prepared in the setup procedure, aligning the tires within the four tape markings on the floor.

If applicable, ensure any shimming done during measurement and leveling is under the tire and does **NOT** slip out.

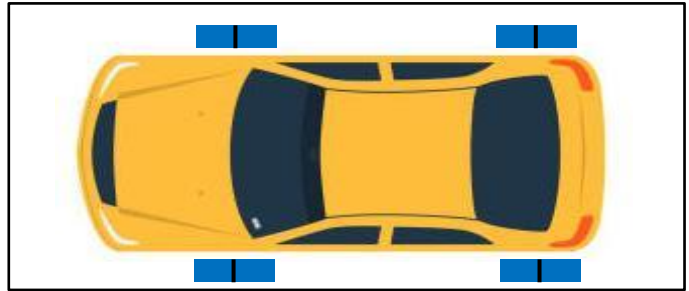

2. Ensure **both** the left and right low beam center markings (A) are at **118 1/8 in. (300 cm)** from the wall/screen.

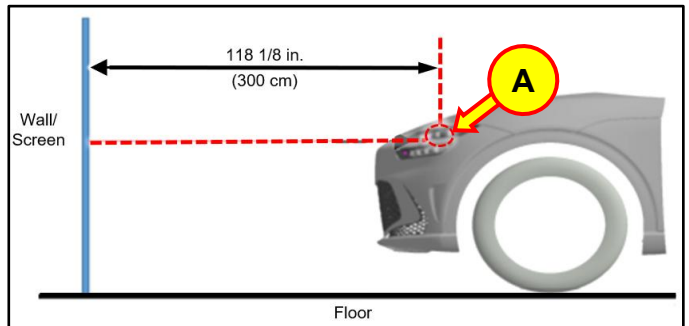

3. Apply a piece of tape next to the low beam center marking (A) on both headlamps.

***i* Information**

This will make it easier to align the laser beam on the headlamps.



- Position the tripod and laser centered directly in front of the vehicle at **59 1/16 in. (150 cm)** from the low beam center marking (A) on the headlamps.

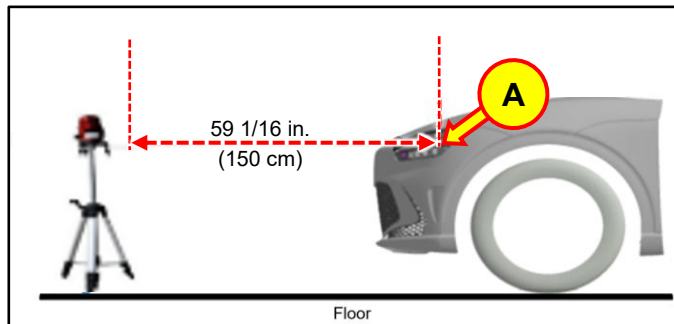

Turn on the laser beam (B) and adjust to ensure it is evenly crossing the low beam center markings (A) on both headlamps.

i Information

This will confirm that the vehicle is level.

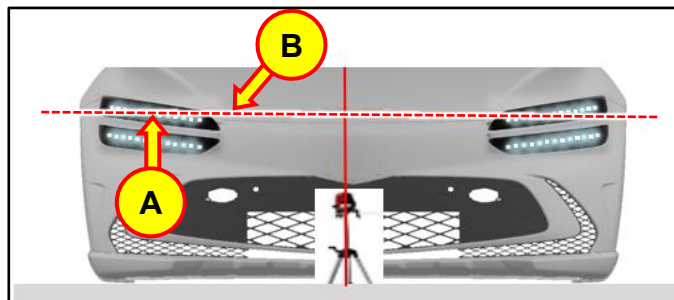

- Using a tape measure, measure the height of the laser beam to the ground or top of shims (if applicable). This measurement is the ground clearance of the headlights.

i Information

If the tire is shimmed then the ground level is the top of the shim.

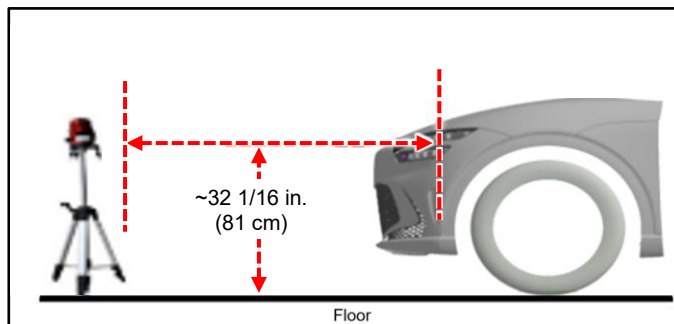

- Ground clearance height (approx.) = **32 1/16 in. (81 cm)**

- Project the laser beam onto the wall at this height, and apply masking tape on the wall along the laser beam line (C) as shown.

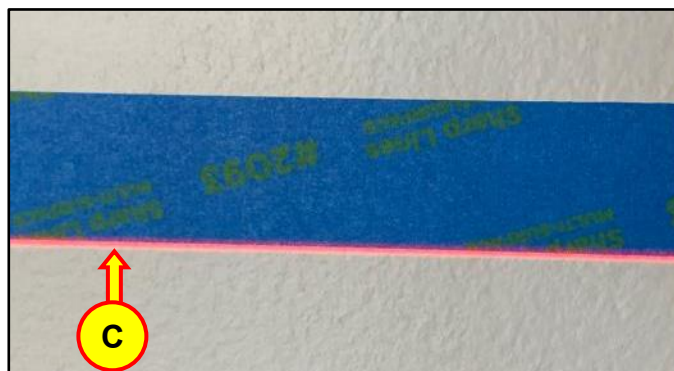

- Remove the masking tape from the headlamps, and turn **ON** the low beam headlamps.

8. Confirm that the top of **BOTH** headlamp beams, also known as the cut-off line (D), is **NO** higher than the taped line on the wall, which matches the ground clearance measured in step 5.

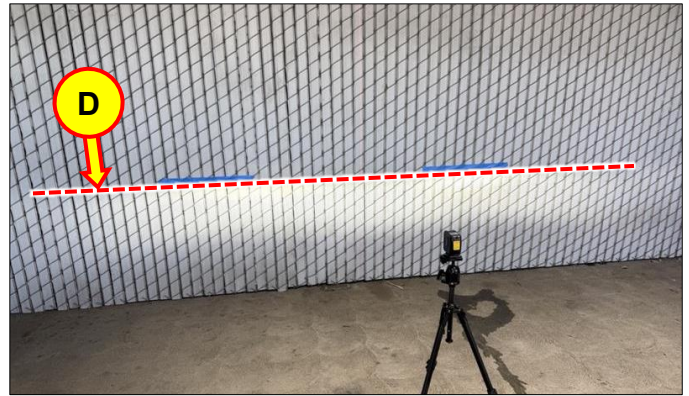

i Information

The cut-off line is defined as the boundary line between the brightest part and the darkest part of the headlamp beams shining on the wall.

If the cut-off line needs to be adjusted higher or lower, it is best to concentrate on the brightest part of the beam (E), approx. **4 1/8 in. (10.5 cm)** to the right from where the notch ends.

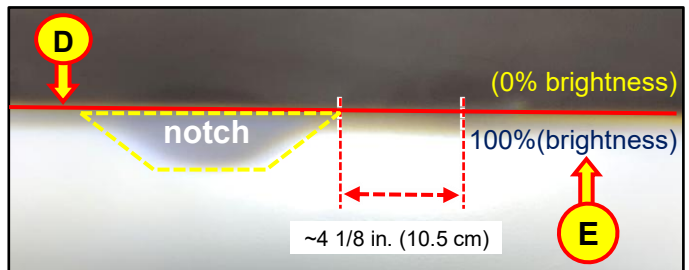

9. To adjust the headlamp beams, insert a long Phillips screwdriver into either adjusting hole (F) and turn it clockwise or counterclockwise to adjust.

i Information

Perform headlamp beam adjustment with vehicle unoccupied. The vehicle **MUST** be empty.

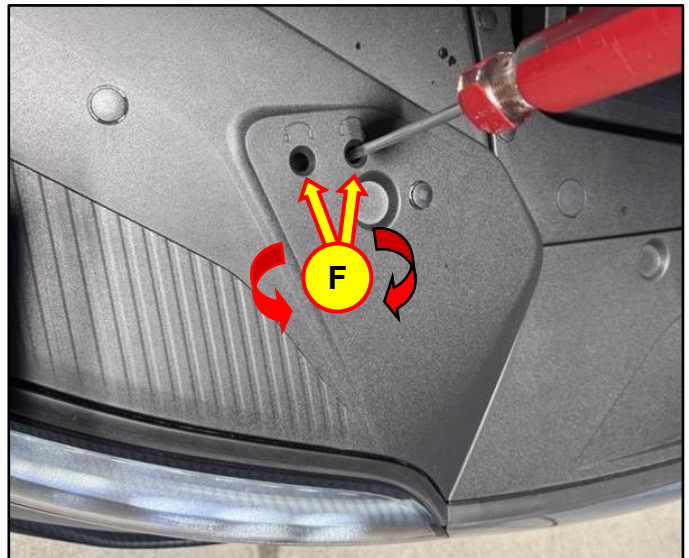

i Information

GV60 has 2 separate adjusting holes: 1 to adjust the height of the beam, and 1 to adjust the level.

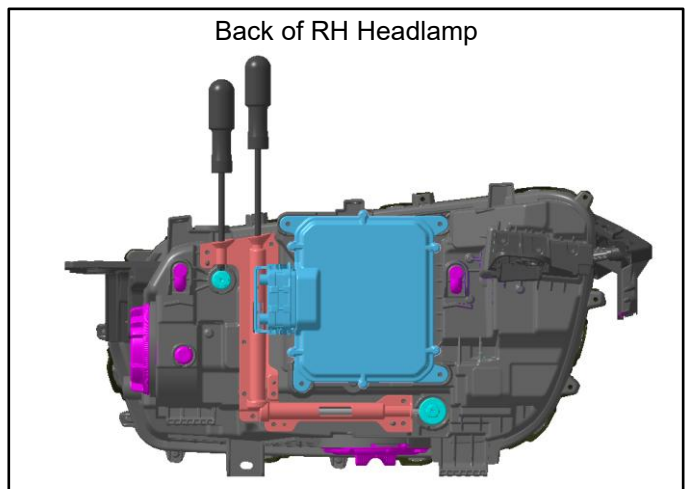

10.

**DIGITAL
DOCUMENTATION**

Using the STUI camera function, take a photo of the new headlamp beams aligned correctly on the wall/screen from the driver's seat.

Upload the photo to STUI.

NOTE: If the STUI camera function is **NOT** used, write the last 6 digits of the VIN and date of repair on a piece of paper to include in the photo.



11. The service procedure is now complete.

**Information**

If possible, leave the tape markings and shims in place so the steps done in [Headlamp Beam Aiming: Workstation Setup](#) do **NOT** have to be repeated for the next vehicle.

Repeat the entire [Headlamp Beam Aiming: Validation/Adjustment](#) procedure for each applicable vehicle.

Be sure to follow all steps, including laser beam projection/measurement, as the headlamp beam alignment height may differ slightly for each vehicle.