

Technical Service Bulletin

| | |
|------------------------|---|
| Topic | Front carpets / Mats wet - Musty smell in the cabin - Suspected leak from the water and condensate drains |
| Market area | Bentley: worldwide (2WBE),China 796 VW Import Comp. Ltd (Vico), Beijing (6796) |
| Brand | Bentley |
| Transaction No. | 2075712/2 |
| Level | EH |
| Status | Released for publishing |
| Release date | Sep 24, 2025 |

New customer code

| Object of complaint | Complaint type | Position |
|--|---|----------|
| climate control -> air distribution, filtration, fans | leaks | |
| vehicle service -> inspection, maintenance -> performing a service | service: process -> with complaint confirmation | |

Vehicle data

New Continental GT/C and New Flying Spur

Sales types

| Type | MY | Brand | Designation | Engine code | Gearbox code | Final drive code |
|------|------|-------|-------------|-------------|--------------|------------------|
| Z23* | 2025 | E | | * | * | * |
| Z23* | 2026 | E | | * | * | * |
| Z24* | 2025 | E | | * | * | * |
| Z24* | 2026 | E | | * | * | * |
| Z32* | 2025 | E | | * | * | * |
| Z32* | 2026 | E | | * | * | * |

Documents

| |
|----------------------|
| Document name |
| master.xml |

Condition

Customer statement

- Water ingress into the left and/or right hand foot well
- Front carpets and/or foot mats are wet
- Musty smell in the cabin

Technical Background



NOTICE

Please also consider TPI 2075713/- as the described symptoms are similar however the repair method is different

In the event the issue is as described please refer to the instructions within the Measure section



CAUTION

Please ensure all guidelines within the repair manual are strictly followed before and whilst conducting any work on vehicles with a High voltage system

Production Solution

Not applicable

Service



NOTICE

Before conducting the onward instructions the operative must confirm the leak is from the left and right hand water and condensate drains as follows:

- 1) Referring to Figure 1 - Remove the (x2) fixings 3.5Nm (point 1) and remove the left and right hand lower panels

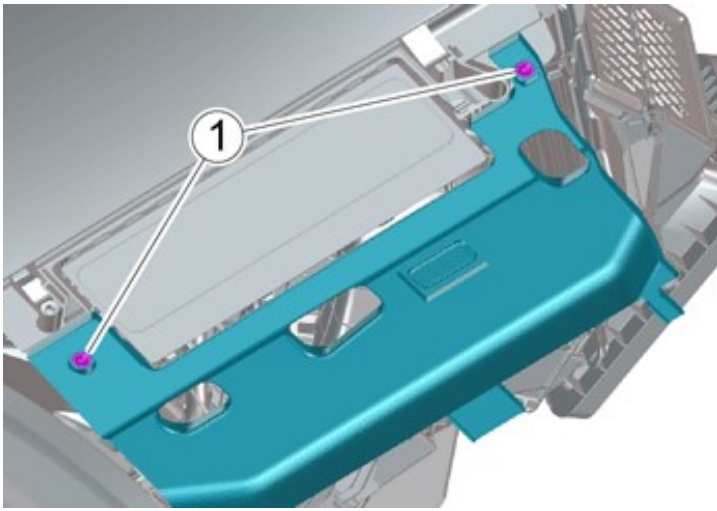

Figure 1

2) with care manoeuvre the carpet in the direction shown (ARROW) until the water and condensate drains can be located



Figure 2

3) Ensure the vehicle is parked in a well ventilated area / ensure exhaust extraction equipment is used

- Start up the engine
- Switch on the A/C system to Max (Figure 3)



Figure 3

- Allow the engine to idle for 5 minutes
- Referring to Figure 4 - After 5 minutes has elapsed
- Check the left and right hand condensate drains for signs of moisture residue stains (A)
- Check the hoses for signs of water leaks (B)



Figure 4

NOTICE

In the event that water is leaking from the condensate drain hoses at the points shown in Figure 4 or moisture residue stains are evident the operative should conduct the remaining instructions from step 4 on the left and right hand side

4) Referring to Rep.Gr 87 - Remove the left and right hand front carpets to gain access to the water and condensate drains

Left hand side

CAUTION

Take caution when removing the condensate drain from the drain tube, as this can be difficult to relocate without accessing the underside of the vehicle and removing several components

5) Referring to Figure 5 - Disconnect points A,B and C and apply silicone sealant as described in the onward instructions

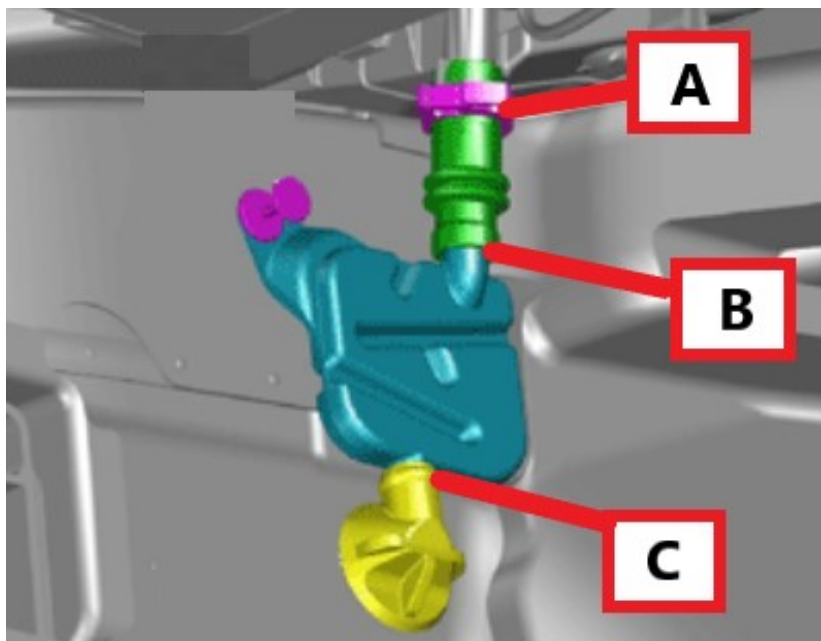

Figure 5

Point A

- Disconnect the rubber hose from the HVAC drain
- Clean and dry the inside of the rubber hose and HVAC drain plastic pipe
- Apply a thin layer of silicone sealant to the inside of the rubber hose and plastic drain pipe

Point B

- Disconnect the rubber hose from the condensate drain (Upper)
- Clean and dry the inside of the rubber hose and condensate drain pipe
- Apply a thin layer of silicone sealant to the inside of the rubber hose and condensate drain pipe

Point C

- Disconnect the upper rubber hose from the condensate drain (Lower)
- Clean and dry the inside of the rubber hose and condensate drain pipe
- Apply a thin layer of silicone sealant to the inside of the rubber hose and condensate drain pipe

6) Reconnect all previously disconnected hoses (A,B and C)

7) Allow the sealant to cure (Refer to sealant manufacturers guidelines)

Right hand side

8) Conduct step 5,6 and 7 on the right hand side

Both sides continued

9) Once the sealant has cured repeat step 3 to confirm the issue is resolved



The carpets, surrounding area and components must be dry before refitting the carpets

10) In the event the issue is resolved refit the left and right hand side front carpets as referenced within Rep. Gr 87

Or

Should the issue not be resolved please raise a DISS query and await feedback before conducting any further work

Warranty

Warranty type 110 or 910

Damage Service number 70 41

Damage code 00 49

New Continental GT / C

Time to remove and refit the left and right hand side front carpets

Labour Operation Code 70 41 20 00

Time 330 TU

New Flying Spur

Time to remove and refit the left and right hand side front carpets

Labour Operation Code 70 41 20 01 (Use 99 index until 05/12/24)

Time 270 TU

All Models

Time to check the left and right hand water and condensate drains (steps 1,2 and 3)

Labour Operation Code 87 91 01 98 (Use 99 index until 05/12/24)

Time 20 TU

Time to apply the sealant to the left and right hand side water and condensate drain hoses (top and bottom)

Labour Operation Code 87 91 52 98 (Use 99 index until 05/12/24)

Time 20 TU

Required Parts and Tools



Silicone sealant to be sourced locally